

General Catalogue



Gearboxes Made in Italy



DOSSIER ACCORDING
TO 94/9/EG & B II
STORED



HYDRONEMO

3 CLICKS SELECTION

Use the best of our webs database to get detailed information like, mounting position, lubrication and many others available for each size, always updated.

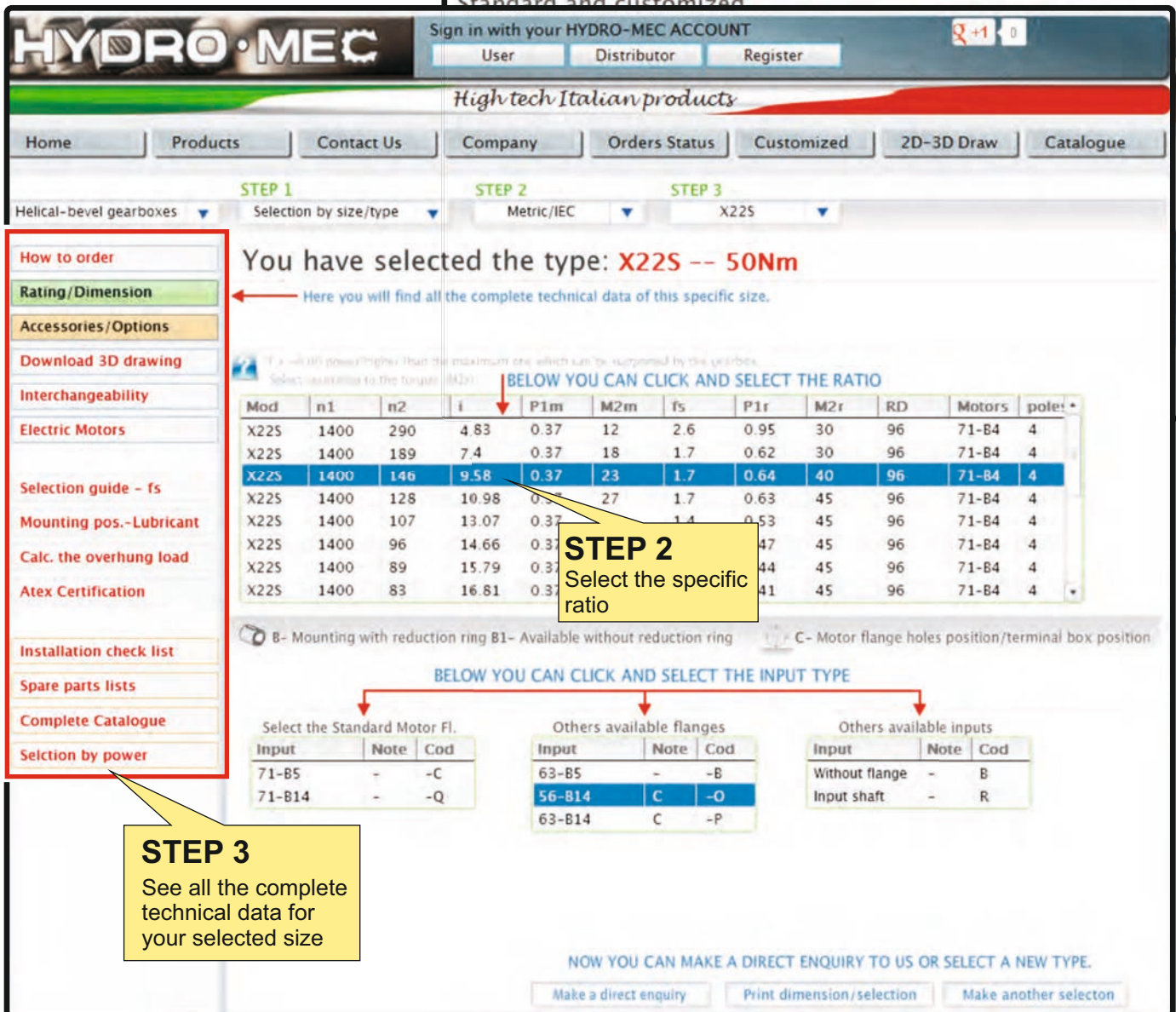

IN THIS CATALOGUE



Rightangle-Gear

Worm gearboxes
Riduttori a vite senza fine

Paragraph **1**



Square-Gear

Square worm gearboxes
Riduttori a vite senza fine quadri

Paragraph **2**



Hightech-Gear

S series square worm gearboxes
Riduttori a vite senza fine quadri serie S

Paragraph **3**



One step-Gear

One step gearboxes
Riduttori a uno stadio

Paragraph **4**



Coaxial-Gear

Aluminum gearboxes
Riduttori coassiali in alluminio

Paragraph **5**



Coaxial-Gear

Cast iron gearboxes
Riduttori coassiali in ghisa

Paragraph **6**



Compact-Gear

Shaft mounted gearboxes
Riduttori ad assi paralleli

Paragraph **7**



Angletech-Gear

Helical bevel gearboxes
Riduttori a coppia conica

Paragraph **8**



Stainlesssteel-Gear Worm gearboxes

Full stainless steel worm gearboxes
Vite senza fine completamente in acciaio inox

Paragraph **9**



Stainlesssteel-Gear One Step gearboxes

Full stainless steel one step gearboxes
Coassiale ad uno stadio completamente in acciaio inox

Paragraph **10**



Electric motors

Aluminum and stainless steel electric motors
Motori elettrici in alluminio e acciaio inox

Paragraph **M**

Worm gearboxes type 030 ÷ 110

A modular and compact product

Single-piece aluminum alloy housing

Is vacuum impregnated (MIL-STD 276) for protection and sealing. No secondary finish required but readily accepts paint. Combines light weight with high tensile strength. Precision machined for alignment of bearings and gearing.

Single piece alloy steel input shaft and worm shaft.

High helix angle worm is case-hardened (Rc 58-60), ground, teeth are profiled and radiused, for noise reduction and enhanced efficiency.

Oversized bearings

Support positively-retained, high speed shaft for higher shock load capacity - ideal for frequent starting and reversing application. Premium, Nitrile® high temperature seals each end.

Bronze alloy worm gears.

Is centrifugally cast onto an iron hub for maximum strength and superior life.

Over-size bearing

For radial load capability and maximum hollow output shaft diameter.

Impregnated and machined bearing caps

With exterior machined surfaces enable a variety of mounting accessories. Extra-deep thread engagement provided for greater support strength. Zinc plated hardware.

Flange

Fully modular to IEC and compact integrated motor. NEMA C flange.

Premium, high temperature

Nitrile® output seals

Standard hollow output shaft mounting

Reduces total drive envelope size, weight and cost. Single and double solid output shaft is available.

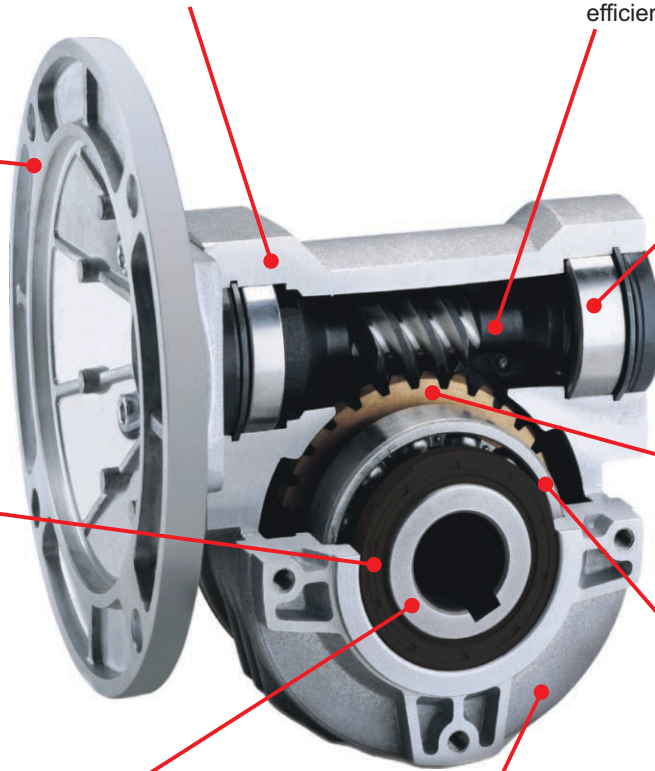

Vent Free Design.

No breather or vents to leak! Factory lubricated for life with synthetic, semi-fluid gear lubricant with an operating range of -15°C to 130°C.

oil free



vent free



Specific type datasheet on page...

On page / A pagina / Auf Seite / À la page / En la página

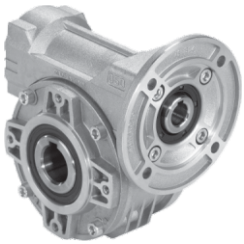

Types / Tipi /
Tipen / Types /
Tipos →

1-5	1-7	1-9	1-11	1-13	1-15	1-17
030 21Nm	045 41Nm	050 72Nm	063 147Nm	63A 191Nm	085 347Nm	110 651Nm

On page / A pagina / Auf Seite / À la page / En la página

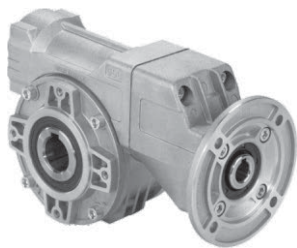

Types / Tipi /
Tipen / Types /
Tipos →

1-19	1-21	1-23	1-25	1-27	1-29
P45 55Nm	P50 88Nm	P63 187Nm	P6A 218Nm	P85 440Nm	P10 803Nm

On page / A pagina / Auf Seite / À la page / En la página

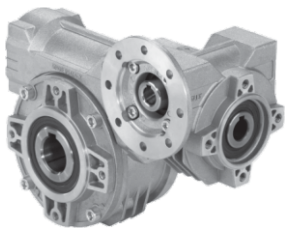

Types / Tipi /
Tipen / Types /
Tipos →

1-31	1-33	1-35	1-37	1-39	1-41	1-43	1-45	1-47
303 35Nm	453 69Nm	503 109Nm	633 230Nm	634 265Nm	6A3 290Nm	6A4 304Nm	854 518Nm	115 978Nm

Type - Tipo - Typ
Type - Tipo

Size - Grandezza
Größe - Taille
Tamaño

Mounting - Montaggio - Montage Fixation
Fixation - Tipo de montaje

P

045

PA

Worm gearboxes
Riduttori a vite senza fine
Schneckengetriebe
Reducteurs a vis sans fin
Reductores de corona sin fin

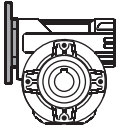

P

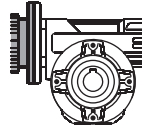

M

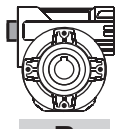

B

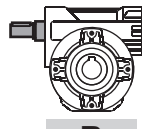

R

030
045
050
063
63A
085
110

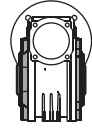

FB

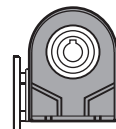

PB

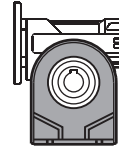

PA

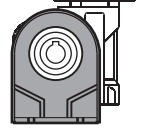

PV

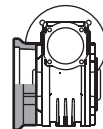

FC

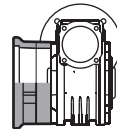

FL

F1
F2
F3
F4

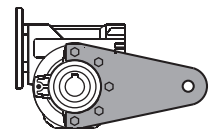

BR

Worm gearboxes with primary reduction
Riduttori a vite senza fine con precoppia
Schneckengetriebe mit stirradstufe am Eintrieb
Reducteurs a vis sans fin avec pré-réduction
Reductores corona sin fin con prereducora de engranajes

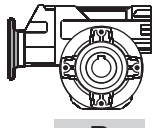

P

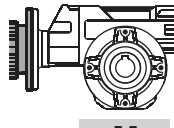

M

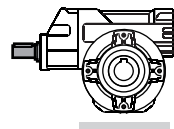

R

P45
P50
P63
P6A
P85
P10

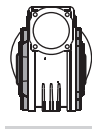

FB

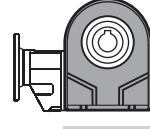

PB

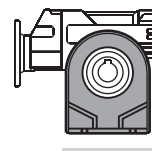

PA

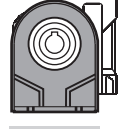

PV

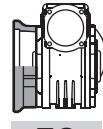

FC

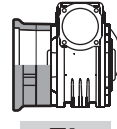

FL

F1
F2
F3
F4

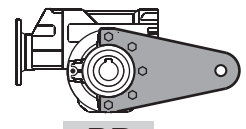

BR

Combined worm gearboxes
Riduttori a vite senza fine combinati
Schneckengetriebekombinationen
Reducteurs a double train de vis sans fin
Reductores combinados corona sin fin

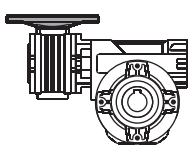

P

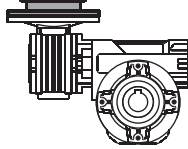

M

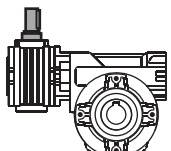

R

303
453
503
633
634
6A3
6A4
854
115

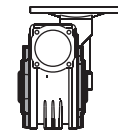

FB

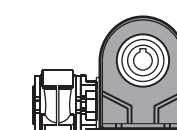

PB

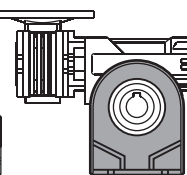

PA

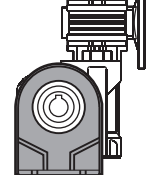

PV

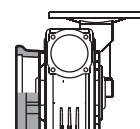

FC

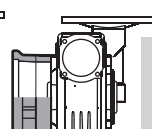

FL

F1
F2
F3
F4

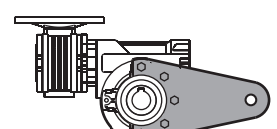







BR

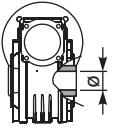
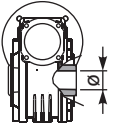
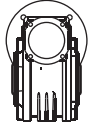
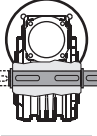
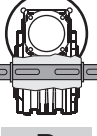
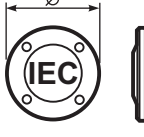

On request we can deliver our products according to the ATEX
A richiesta possiamo fornire i nostri prodotti secondo le normative ATEX
Auf Anfrage können wir unsere Produkte den Richtlinien ATEX entsprechend liefern
Sur demande nos produits peuvent se conformer à la réglementation ATEX
A pedido, se pueden enviar nuestros productos de acuerdo con las normas ATEX.

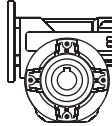
CODIFICA / HOW TO ORDER / TYPENBEZEICHNUNGEN / CODIFICATION / CODIFICACIÓN

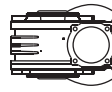
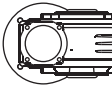
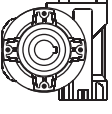
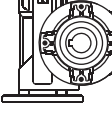
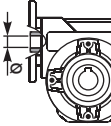
Ratio Rapporto Untersetzung Reduction Relación	Hub Mozzo corona Hohlwelle Arbre creux Nucleo corona	Output shaft Albero lento Abtriebswelle Arbre de sortie Eje solida	Motor size Grandezza motore Motor Grösse Grandeur moteur Tamaño motor	Terminal box position Posizione morsetti Klemmkastenlage Position boîte a bornes Posición caja de bornes	Mounting position Posizione montaggio Einbaulage Position de montage Posición de montaje	Reduced Input bore Foro entrata ridotto Reduzierte Eingangshohlwelle Trou d'entree de diametre reduit Eje hueco de entrada reducido	Mountin position Esecuzione montaggio Einbaulage Exécution de montage Posición de montaje
10	C	∅	-Q	B	B3	-	---
See technical data table Vedi tabella dati tecnici. Technisches Datenblatt beachten Voir tableau données techniques Ver tabla datos técnicos	 C STANDARD 030 ⇨ ∅14 045 ⇨ ∅18 050 ⇨ ∅25 063 ⇨ ∅25 63A ⇨ ∅28 085 ⇨ ∅35 110 ⇨ ∅42 I Stainless steel hub Mozzo in acciaio Inox Edelstahlhohlwelle Moyeu en acier Inox Nucleo corona de acero Inox Special series Serie Speciale S 045 ⇨ ∅19 050 ⇨ ∅24 X Stainless steel hub Mozzo in acciaio Inox Edelstahlhohlwelle Moyeu en acier Inox Nucleo corona de acero Inox  U INCH 045 ⇨ ∅0.750" 050 ⇨ ∅1.000" 063 ⇨ ∅1.125" 085 ⇨ ∅1.500"	 ∅  S  D	 -M without flange Senza flangia B5 -A=56 (∅120) -B=63 (∅140) -C=71 (∅160) -D=80 (∅200) -E=90 (∅200) -F=100+112 (∅250) -G=132 (∅300) B14 -O=56 (∅80) -P=63 (∅90) -Q=71 (∅105) -R=80 (∅120) -T=90 (∅140) -U=100+112 (∅160) -V=132 (∅200) -0=Type R -S=Type R S series Reduced Fl. -1=56B5/∅11 -2=63B5/∅14 -3=71B5/∅19 -4=71B5/∅24 -5=90B5/∅28 -6=100B5/∅38 -7=132B5/∅42 -8=80B14/∅11 -9=100B5/∅24	 A  B STANDARD  C  D	 B3  B8  B6  B7  V5  V6	 - Nothing indication standard bore Nessuna indicazione foro standard P Input bore reduced one size Foro entrata ridotto di una misura Ex. Input Flange 71 B14 Standard ∅14 Reduced ∅11 Q Input bore reduced two sizes Due grandezze ridutte foro entrata Ex. Input Flange 71 B14 Standard ∅14 Reduced ∅9	Only for combined units See technical data table Solo per i riduttori combinati Vedi tabella dati tecnici. Ausführungen für Getriebekombinationen it Uniquement pour combinés. Voir tableau données techniques Sólo para combinados ver tabla datos técnicos

POTENZA RICHIESTA / REQUIRED POWER / ERFORDERLICHE LEISTUNG / PUISSANCE NECESSAIRE / POTENCIA NECESARIA

Lifting / sollevamento / hubantriebe / levage / elevación

$$P \text{ [KW]} = \frac{M \text{ [Kg]} \cdot g \text{ [9.81]} \cdot v \text{ [m / s]}}{1000}$$

Rotation / rotazione / drehung / rotation / rotação

$$P \text{ [KW]} = \frac{M \text{ [Nm]} \cdot n \text{ [rpm]}}{9550}$$

Linear movement / traslazione / linearbewegung / translation / translación

$$P \text{ [KW]} = \frac{F \text{ [N]} \cdot v \text{ [m / s]}}{1000}$$

TORQUE / COPPIA / DREHMOMENT / COUPLE / PAR

$$M \text{ [Nm]} = \frac{9550 \cdot P \text{ [KW]}}{n \text{ [rpm]}}$$

$$M \text{ [lb in]} = \frac{63030 \cdot P \text{ [HP]}}{n \text{ [rpm]}}$$

RADIAL LOADS / CARICHI RADIALI / RADIALE - UND AXIALLASTEN / CHARGES RADIALES / CARGA RADIAL Y AXIAL

- Radial load generated by external transmissions keyed onto input and/or output shafts.
- Forza radiale generata da organi di trasmissione calettati sugli alberi di ingresso e/o uscita.
- Belastungen der Antriebs- bzw. Abtriebswellen durch von aussen eingebrachte Radiallasten.
- Charge radiale générée par la transmissions calés sur les entrées et / ou des arbres de sortie
- Cargas radiales, generada por transmisiones externas, aplicadas sobre los ejes de entrada y/o salida

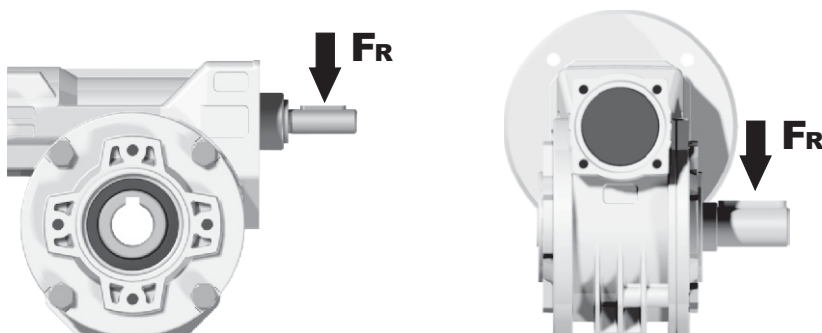

	$F_R \text{ [N]} = \frac{M \text{ [Nm]} \cdot 2000}{d \text{ [mm]}} \cdot f_k$	$F_R \text{ [N]} = \frac{M \text{ [lb in]} \cdot 8.9}{d \text{ [in]}} \cdot f_k$
M	Momento torcente / Output torque / Abtriebsdrehmoment / Couple / Par torsion	
d	Diametro primitivo / Diam. of driving element / Durchmesser der Abtriebseinheit / Diamètre primitif / Diámetro primitivo	
f_k	Coefficiente di trasformazione / Factor / Faktor / Coefficient de transmission / Coeficiente de transmisión 1.15 Ingranaggi / Gearwheels / Zahnrad / Engrenage / Engranaje 1.25 Catena / Chain sprockets / Antriebskette / Chaîne / Cadena 1.75 Cinghia Trapezoidale / Narrow v-belt pulley / Keilriemen / Courroie trap. / Correa trapezoidal 2.50 Cinghia piatta / Flat-belt pulley / Flachzahnriem. / Courroie crantée / Correa plana	

- If your application requires higher radial loads, contact our technical office. Higher load may be possible.
- Nel caso la vostra applicazione richieda carichi radiali superiori consultare il nostro ufficio tecnico, valori maggiori possono essere accettati.
- Wenn Ihre Anwendung höhere Radialbelastungen erfordert, so wenden Sie sich bitte an unser technischen Büro.
- Si votre application demande des charges radiales supérieures, s'adresser à notre bureau technique.
- En el caso en que una aplicación exija una carga radial superior a la especificada en el catálogo, consultar a nuestra oficinas técnica.

How to select a gearbox / Come selezionare un riduttore / Wie wählt man ein Getriebe
Comment sélectionner un réducteur / Cómo seleccionar un reductor

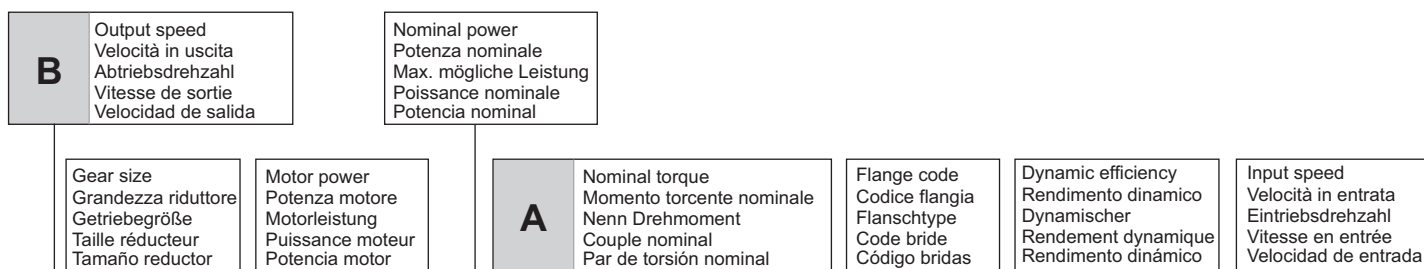

045 Rightangle - Gear
41Nm

Rating - Aluminum WORM GEARBOXES



QUICK SELECTION / Selezione veloce input speed (n_1) = 1400 min⁻¹

Output Speed n_2 [min ⁻¹]	Ratio i	Motor power P_{1M} [kW]	Output torque M_{2M} [Nm]	Service factor f.s.	Nominal power P_{1R} [kW]	Nominal torque M_{2R} [Nm]	Available B5 motor flanges		Available B14 motor flanges			Dynamic efficiency	Tooth Module [mm]	Ratios code
							B	C	O	P	Q			
200	7	0.37	14	2.2	0.80	30	B		B-C	B-C		80	2.2	01
140	10	0.37	20	1.5	0.57	30	B		B-C	B-C		79	2.2	02
100	14	0.37	27	1.1	0.41	30	B		B-C	B-C		77	2.4	03



fs

Type of load and starts per hour Tipo di carico e avviamenti per ora		Oper. hours per day Ore di funz. giorn.		
		<2 h	2 - 8 h	8 - 16 h
Continuous or intermittent appl. with start / hour Applicazione cont. o interm. con n.ro operazioni/ora	Uniform / Uniforme	0.9	1	1.25
	Moderate / Moderato	1	1.25	1.5
	Heavy / Forte	1.25	1.5	1.75
Intermittent application with start / hour Applicazione intermittente con n.ro operazioni/ora	Uniform / Uniforme	1.25	1.5	1.75
	Moderate / Moderato	1.5	1.75	2
	Heavy / Forte	1.75	2	2.25

D Motor flange available
Flange disponibili
Erhältliche Motorflansche
Brides disponibles
Bridas disponibles

B) Mounting with reduction ring
Montaggio con boccolla di riduzione
Reduzierhülsen
Montage avec douille de réduction
Montaje con casquillo de reducción

C) Motor flangeholes position/terminal box position
Posizione fori flangia/basetta motore
Bohrungsposition am Motorflansch/-sockel
Position trous bride/barrette à bornes moteur
Posición agujeros brida / base motor

B) Available without reduction bushes
Disponibile anche senza boccolla
Auch ohne Reduzierbuchse verfügbar
Disponible aussi sans douille de réduction
Disponible tambien sin casquillo

A	Select required torque (according to service factor)	Seleziona la coppia desiderata (comprensiva del fattore di servizio)	Max. Drehmoment in Bezug zum Betriebsfaktor	Sélectionner le couple souhaité (comprenant le facteur de service)	Seleccionar el par deseado (incluyendo el factor de servicio)
B	Select output speed	Seleziona la velocità in uscita	Ausgewählte Abtriebsdrehzahl	Sélectionner la vitesse de sortie	Seleccionar la velocidad de salida
C	On the same line of selected geared motor, you can find the gear ratio	Sulla riga corrispondente alla motorizzazione prescelta si può rilevare il rapporto di riduzione	Auf der gleichen Linie wie die ausgewählte Motorleistung steht auch die Getriebeuntersetzung	Sur la ligne correspondante à la motorisation pré-choisie on peut relever le rapport de réduction	En la línea correspondiente al motor preseleccionado es posible encontrar la relación de reducción
D	Select motor flange available (if requested)	Scegli la flangia disponibile (se richiesta)	Erhältliche Motorflansche (auf Anfrage)	Choisir la bride disponible (si elle est demandée)	Seleccionar la brida disponible (sobre pedido)

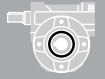

QUICK SELECTION / Selezione veloce

input speed (n_1) = 1400 min⁻¹

Output Speed n_2 [min ⁻¹]	Ratio i	Motor power P_{1M} [kW]	Output torque M_{2M} [Nm]	Service factor f.s.	Nominal power P_{1R} [kW]	Nominal torque M_{2R} [Nm]	Available B5 motor flanges		Available B14 motor flanges		Dynamic efficiency RD	Tooth Module [mm]	Ratios code
							A	B	O	P			
							56	63	56	63			
280	5	0.18	5	3.3	0.60	17	B		B-C		82	1.26	09
200	7	0.18	7	2.4	0.44	17	B		B-C		80	1.44	01
140	10	0.18	10	1.8	0.32	17	B		B-C		78	1.44	02
93	15	0.18	13	1.4	0.25	19	B		B-C		73	1.44	03
70	20	0.18	17	1.1	0.20	19	B		B-C		70	1.09	04
47	30	0.12	15	1.4	0.17	21	B		B-C		62	1.44	05
35	40	0.12	19	1.1	0.13	20	B		B-C		57	1.09	06
23	61	0.09	19	1.1	0.10	20	B		B-C		50	0.72	07
17.5	80	0.09	16	1.0	0.06	16	B		B-C		48	0.56	08

A) Motor Flanges Available
Flange Motore Disponibili

B) Supplied with Reduction Bushing
Fornito con Bussola di Riduzione

B) Available on Request without reduction bushing
Disponibile a Richiesta senza Bussola di Riduzione

C) Motor Flange Holes Position
Posizione Fori Flangia Motore

EN Unit **030** is supplied with synthetic oil, providing "long life" lubrication. For mounting position V5-V6 please contact us. See table 1 for lubrication and recommended quantity. In table 2 please see possible radial loads and axial loads on the gearbox.

I Il riduttore tipo **030** viene fornito lubrificato a vita con olio sintetico. Per posizioni V5-V6 contattare il ns. servizio tecnico. Vedi tab.1 per oli e quantità consigliati. In tab.2 sono presenti i carichi radiali e assiali applicabili al riduttore.

D Für die Lebensdauerschmierung ist das Getriebe der Größe **030** mit synthetischem Öl befüllt. Bei Einbaulage V5 oder V6 bitten wir um Rücksprache. In Tabelle 1 ist die Schmiermenge und das empfohlene Schmiermittel angegeben. In Tabelle 2 sind die zulässigen Radial- und Axialbelastungen des Getriebes aufgeführt.

F Le réducteur de type **030** est fourni lubrifié à vie avec de l'huile synthétique. Concernant les positions V5.V6, contactez notre service d'assistance technique. Voir tableau 1 concernant les huiles et les quantités conseillées. Les charges radiales et axiales applicables au réducteur sont précisées dans le tableau 2.

E El reductor tamaño **030** se suministra, lubricado de por vida con aceite sintético. Para las posiciones V5 y V6 contactar con nuestro servicio técnico. Ver tabla 1, para cantidades y aceites recomendados. En la tabla 2, se encuentran las cargas radiales y axiales admitidas por el reductor.

LUBRICATION 030 Oil Quantity 0.03 Lt.

AGIP Telium VSF 320

SHELL Omala S4 WE 320

For all details on lubrication and plugs check our website **tab. 1**
Per maggiori dettagli su lubrificazione e tappi olio vedi il nostro sito web

RADIAL AND AXIAL LOADS

Output shaft

Albero di uscita

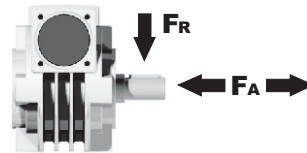

n_2 [min ⁻¹]	FA [N]	FR [N]
200	120	600
150	140	700
100	160	800
75	180	900
50	200	1000
25	250	1250
15	280	1400

Input shaft

albero in entrata

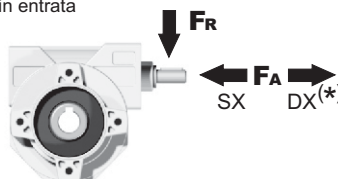

n_1 [min ⁻¹]	FA [N]	FR [N]
1400	20	100

***Strong axial loads in the DX direction are not allowed.**
Non sono consentiti forti carichi assiali con direzione DX

tab. 2

P030FB... Basic wormbox
Riduttore base

Gearbox weight
peso riduttore **1.05 kg**

M. flanges	Kit code	øF	A
56B5	K030.4.041	120	61.5
63B5	K030.4.042	140	62.5
56B14	K030.4.046	80	61.5
63B14	K030.4.045	90	62.5

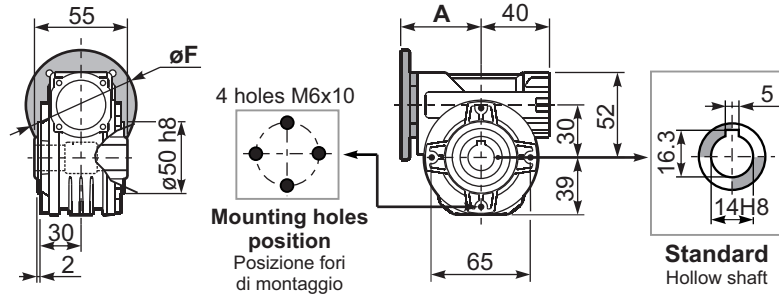

P030PA... Feet
Piedini

P030PB... Feet
Piedini

P030PV... Feet
Piedini

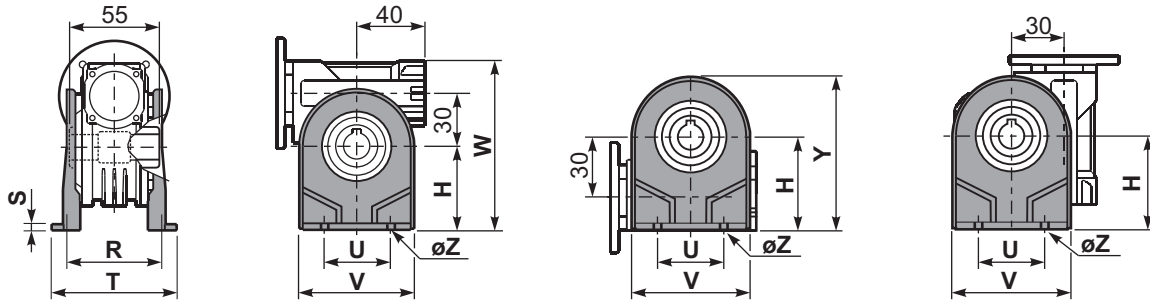

	H	R	S	T	U	V	Y	W	øZ	kit code
type B	55	66	3	87	50	78	94	107	ø6.5	K030.9.022
type S	52	66	3	87	52	90	91	104	ø6.5	KS030.9.023

P030FC... Output flange
Flangia uscita

P030BR... Reaction arm
Braccio di reazione

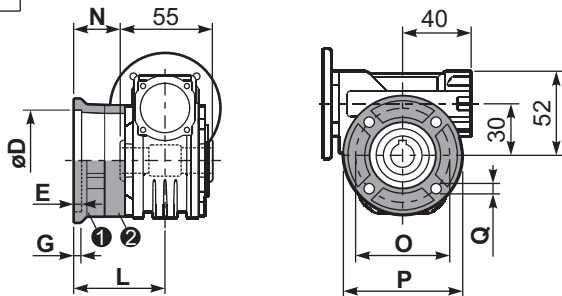

type B	øD	E	G	L	N	O	P	Q	kit code
FC	50 ^{+0.15} / _{+0.05}	6	6	50.5	23	68	80	7	1 K030.9.010 2 -
FL	60 ^{+0.15} / _{+0.05}	6	6	55.5	28	87	110	8.5	1 K045.9.010 2 -
type S	øD	E	G	L	N	O	P	Q	kit code
F1	40 ^{+0.15} / _{+0.10}	3.5	5.5	49	21.5	56	80	6.5	1 KS030.9.012 2 -

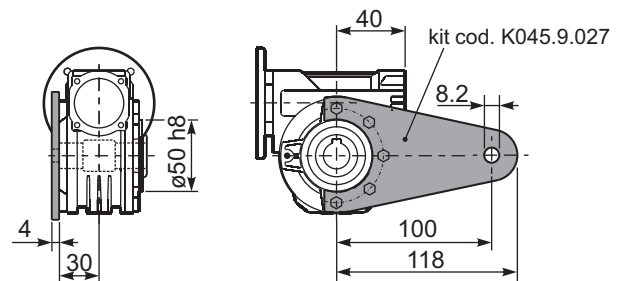

P030.....S... Single Shaft
Albero lento semplice

P030.....D... Double Shaft
Albero lento bisp.

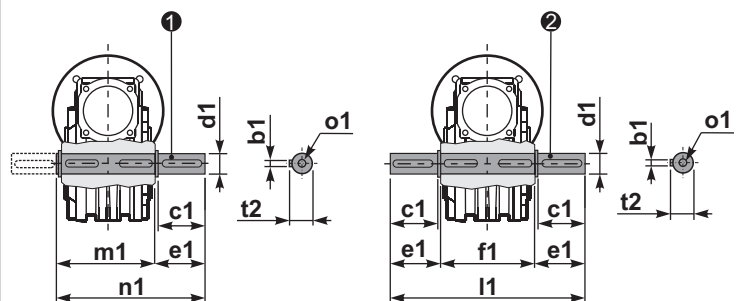

1 kit cod. K030.5.028 type B 2 kit cod. K030.5.029 type B

R030FB... Input shaft
Albero in entrata

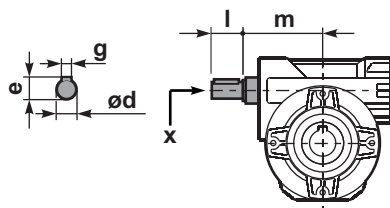

	ød	e	g	l	m	x	kit code
type B	9 h6	10.2	3	20	58	-	K030.5.006 PAM63
type S	-	-	-	-	-	-	-

	b1	c1	d1	e1	f1	l1	m1	n1	t2	o1
type B	5	25	14 ^{-0.005} / _{-0.020}	35.5	55	126	59	94.5	16	M5x14
type S	-	-	-	-	-	-	-	-	-	-

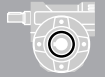

QUICK SELECTION / Selezione veloce

input speed (n_1) = 1400 min⁻¹

Output Speed n_2 [min ⁻¹]	Ratio i	Motor power P_{1M} [kW]	Output torque M_{2M} [Nm]	Service factor f.s.	Nominal power P_{1R} [kW]	Nominal torque M_{2R} [Nm]	Available B5 motor flanges		Available B14 motor flanges			Dynamic efficiency RD	Tooth Module [mm]	Ratios code
							B	C	O	P	Q			
							63	71	56	63	71			
200	7	0.37	14	2.2	0.80	30	B		B-C	B-C		80	2.2	01
140	10	0.37	20	1.5	0.57	30	B		B-C	B-C		79	2.2	02
100	14	0.37	27	1.1	0.41	30	B		B-C	B-C		77	2.4	03
67	21	0.37	36	1.2	0.43	41	B		B-C	B-C		67	1.6	04
50	28	0.25	31	1.3	0.33	41	B		B-C	B-C		65	2.5	05
38	37	0.25	40	1.0	0.26	41	B		B-C	B-C		63	1.8	06
30	46	0.25	46	0.9	0.22	41	B		B-C	B-C		59	1.5	07
23	60	0.18	41	1.0	0.18	41	B		B-C	B-C		56	1.2	08
20	70	0.12	31	1.0	0.12	30	B		B-C	B-C		54	1.0	09
13.7	102	0.09	31	1.0	0.09	29	B		B-C	B-C		49	0.72	10

A Motor Flanges Available
Flange Motore Disponibili

B Supplied with Reduction Bushing
Fornito con Bussola di Riduzione

B Available on Request without reduction bushing
Disponibile a Richiesta senza Bussola di Riduzione

C Motor Flange Holes Position
Posizione Fori Flangia Motore

EN Unit **045** is supplied with synthetic oil, providing "long life" lubrication. For mounting position V5-V6 please contact us.
See table 1 for lubrication and recommended quantity. In table 2 please see possible radial loads and axial loads on the gearbox.

I Il riduttore tipo **045** viene fornito lubrificato a vita con olio sintetico. Per posizioni V5-V6 contattare il ns. servizio tecnico.
Vedi tab.1 per oli e quantità consigliati. In tab.2 sono presenti i carichi radiali e assiali applicabili al riduttore.

D Für die Lebensdauerschmierung ist das Getriebe der Größe **045** mit synthetischem Öl befüllt. Bei Einbaulage V5 oder V6 bitten wir um Rücksprache. In Tabelle 1 ist die Schmiermenge und das empfohlene Schmiermittel angegeben. In Tabelle 2 sind die zulässigen Radial - und Axialbelastungen des Getriebes aufgeführt.

F Le réducteur de type **045** est fourni lubrifié à vie avec de l'huile synthétique. Concernant les positions V5.V6, contactez notre service d'assistance technique. Voir tableau 1 concernant les huiles et les quantités conseillées. Les charges radiales et axiales applicables au réducteur sont précisées dans le tableau 2.

E El reductor tamaño **045** se suministra, lubricado de por vida con aceite sintético. Para las posiciones V5 y V6 contactar con nuestro servicio técnico. Ver tabla 1, para cantidades y aceites recomendados. En la tabla 2, se encuentran las cargas radiales y axiales admitidas por el reductor.

LUBRICATION 045 Oil Quantity 0.09 Lt.

AGIP Telium VSF 320

SHELL Omala S4 WE 320

For all details on lubrication and plugs check our website **tab. 1**
Per maggiori dettagli su lubrificazione e tappi olio vedi il nostro sito web

RADIAL AND AXIAL LOADS

Output shaft
Albero di uscita

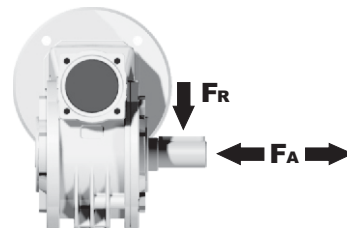

n_2 [min ⁻¹]	FA [N]	FR [N]
200	180	900
150	200	1000
100	220	1100
75	240	1200
50	260	1400
25	300	1800
15	400	2000

Input shaft
albero in entrata

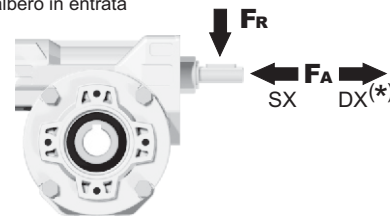

n_1 [min ⁻¹]	FA [N]	FR [N]
1400	42	210

***Strong axial loads in the DX direction are not allowed.**
Non sono consentiti forti carichi assiali con direzione DX

tab. 2

P045FB... Basic wormbox
Riduttore base

Gearbox weight
peso riduttore **2.40 kg**

M. flanges	Kit code	øF	A
63B5	K050.4.041	138	74
71B5	K050.4.042	160	71.5
56B14	KC40.4.049	80	71.5
63B14	K050.4.047	90	74
71B14	K050.4.045	105	71.5

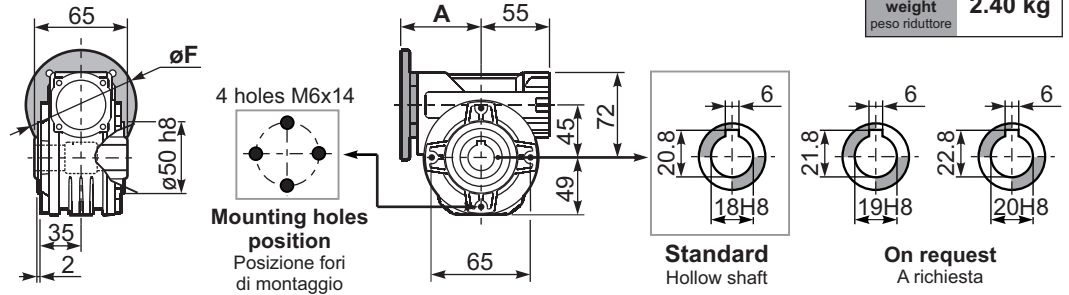

P045PA... Feet
Piedini

P045PB... Feet
Piedini

P045PV... Feet
Piedini

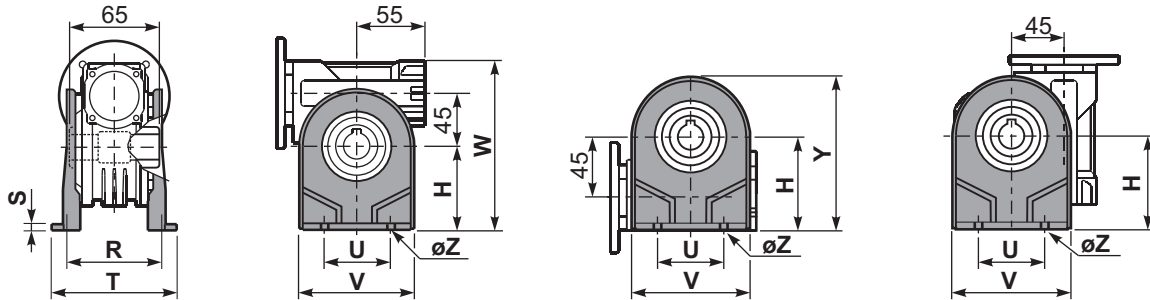

	H	R	S	T	U	V	Y	W	øZ	kit code
type B	72	81	3	100	52	98	121	144	ø10.5	K045.9.022
type S	71	84	8	100	70	90	120	143	ø8	KS045.9.023

P045FC... Output flange
Flangia uscita

P045BR... Reaction arm
Braccio di reazione

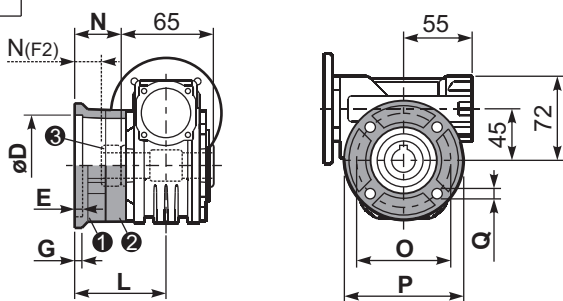

type B	øD	E	G	L	N	O	P	Q	kit code
FC	60 ^{+0.15} / _{+0.05}	9	9	60.5	28	87	110	8.5	1 K045.9.010 2 -
FL	60 ^{+0.15} / _{+0.05}	9	9	90.5	58	87	110	8.5	1 K045.9.010 2 K045.0.200

type S	øD	E	G	L	N	O	P	Q	kit code
F1	95 ^{+0.20} / _{+0.15}	4	11	73.5	41	115	140	9	1 KS045.9.013 2 -
F2	60 ^{+0.15} / _{+0.05}	9	9	60.5	19	87	110	8.5	1 KS045.9.010 2 S045.0.204
F3	80 ^{+0.15} / _{+0.10}	3	8	51.5	19	100	120	9	1 KS045.9.014 2 -

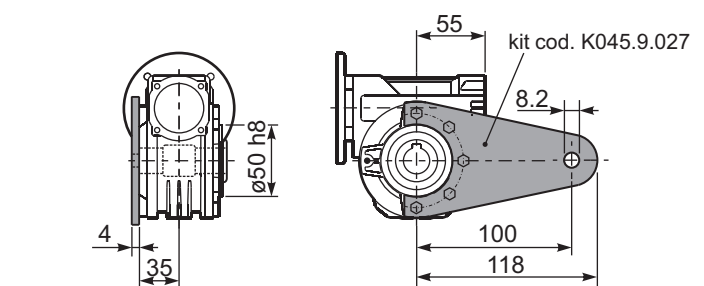

P045.....S... Single Shaft
Albero lento semplice

P045.....D... Double Shaft
Albero lento bisp.

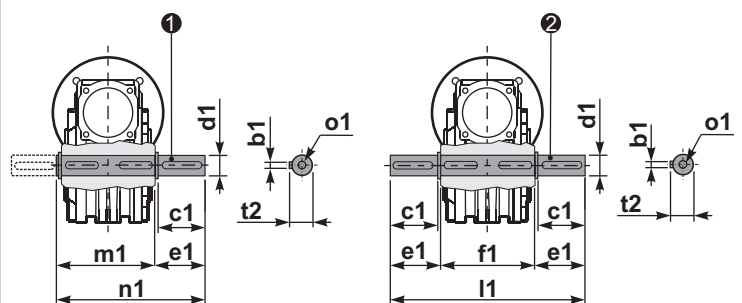

1 kit cod. K045.5.028 type B
kit cod. KS045.5.030 type S

2 kit cod. K045.5.029 type B
kit cod. KS045.5.031 type S

R045FB... Input shaft
Albero in entrata

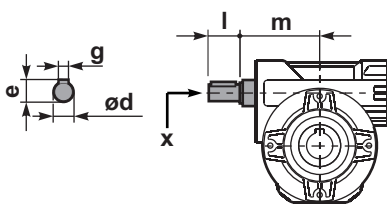

	ød	e	g	l	m	x	kit code
type B	11 h6	12.5	4	30	68	-	1 2 K045.5.006 PAM71
type S	-	-	-	-	-	-	1 2 -

	b1	c1	d1	e1	f1	l1	m1	n1	t2	o1
type B	6	32	18 ^{-0.005} / _{-0.020}	43	65	151	70	113	20.5	M6x18
type S	6	40	19 ^{-0.005} / _{-0.020}	58.8	65	182	70	128.5	21.5	M8x20



QUICK SELECTION / Selezione veloce

input speed (n_1) = 1400 min⁻¹

Output Speed n_2 [min ⁻¹]	Ratio i	Motor power P_{1M} [kW]	Output torque M_{2M} [Nm]	Service factor f.s.	Nominal power P_{1R} [kW]	Nominal torque M_{2R} [Nm]	Available B5 motor flanges			Available B14 motor flanges				Dynamic efficiency RD	Tooth Module [mm]	Ratios code
							B	C	D	O	P	Q	R			
							63	71	80	56	63	71	80			
200	7	0.75	29	1.9	1.5	57	B	B			B-C	B		82	2.5	01
140	10	0.75	41	1.5	1.1	62	B	B			B-C	B		80	2.4	02
100	14	0.75	57	1.2	0.90	68	B	B			B-C	B		79	2.6	03
78	18	0.55	51	1.2	0.67	62	B	B			B-C	B		75	2.0	04
54	26	0.55	67	1.0	0.54	66	B	B			B-C	B		69	2.7	05
47	30	0.55	79	0.9	0.50	72	B	B			B-C	B		70	2.5	12
39	36	0.37	63	1.2	0.43	72	B			B-C	B-C			69	2.1	06
33	43	0.37	72	1.0	0.35	68	B			B-C	B-C			66	1.8	07
23	60	0.25	59	1.0	0.26	62	B			B-C	B-C			58	1.3	08
21	68	0.25	66	0.9	0.22	58	B			B-C	B-C			57	1.2	09
17.5	80	0.18	53	1.1	0.19	57	B			B-C	B-C			54	1.0	10
14	100	0.12	41	1.3	0.15	51	B			B-C	B-C			50	0.8	11

 Motor Flanges Available Flange Motore Disponibili
B Supplied with Reduction Bushing Fornito con Bussola di Riduzione
B Available on Request without reduction bushing Disponibile a Richiesta senza Bussola di Riduzione
C Motor Flange Holes Position Posizione Fori Flangia Motore

EN Unit 050 is supplied with synthetic oil, providing "long life" lubrication. For mounting position V5-V6 please contact us. See table 1 for lubrication and recommended quantity. In table 2 please see possible radial loads and axial loads on the gearbox.

I Il riduttore tipo 050 viene fornito lubrificato a vita con olio sintetico. Per posizioni V5-V6 contattare il ns. servizio tecnico. Vedi tab.1 per oli e quantità consigliati. In tab.2 sono presenti i carichi radiali e assiali applicabili al riduttore.

D Für die Lebensdauerschmierung ist das Getriebe der Größe 050 mit synthetischem Öl befüllt. Bei Einbaulage V5 oder V6 bitten wir um Rücksprache. In Tabelle 1 ist die Schmiermenge und das empfohlene Schmiermittel angegeben. In Tabelle 2 sind die zulässigen Radial - und Axialbelastungen des Getriebes aufgeführt.

F Le réducteur de type 050 est fourni lubrifié à vie avec de l'huile synthétique. Concernant les positions V5.V6, contactez notre service d'assistance technique. Voir tableau 1 concernant les huiles et les quantités conseillées. Les charges radiales et axiales applicables au réducteur sont précisées dans le tableau 2.

E El reductor tamaño 050 se suministra, lubricado de por vida con aceite sintético. Para las posiciones V5 y V6 contactar con nuestro servicio técnico. Ver tabla 1, para cantidades y aceites recomendados. En la tabla 2, se encuentran las cargas radiales y axiales admitidas por el reductor.

LUBRICATION 050 Oil Quantity 0.14 Lt.

AGIP Telium VSF 320

SHELL Omala S4 WE 320

For all details on lubrication and plugs check our website **tab. 1**
Per maggiori dettagli su lubrificazione e tappi olio vedi il nostro sito web

RADIAL AND AXIAL LOADS

Output shaft Albero di uscita

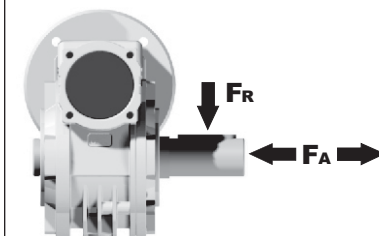

n_2 [min ⁻¹]	FA [N]	FR [N]
200	240	1200
150	280	1400
100	300	1500
75	340	1700
50	380	1900
25	480	2500
15	560	2800

Input shaft albero in entrata

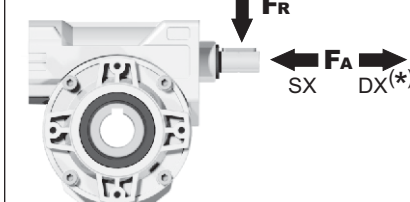

n_1 [min ⁻¹]	FA [N]	FR [N]
1400	76	380

*Strong axial loads in the DX direction are not allowed.
Non sono consentiti forti carichi assiali con direzione DX

tab. 2

P050FB... Basic wormbox
Riduttore base

Gearbox weight
peso riduttore **3.00 kg**

M. flanges	Kit code	øF	A
63B5	K050.4.041	138	78.5
71B5	K050.4.042	160	76
80B5	K050.4.043	200	76.5
56B14	KC40.4.049	80	76
63B14	K050.4.047	90	78.5
71B14	K050.4.045	105	76
80B14	K050.4.046	120	76.5

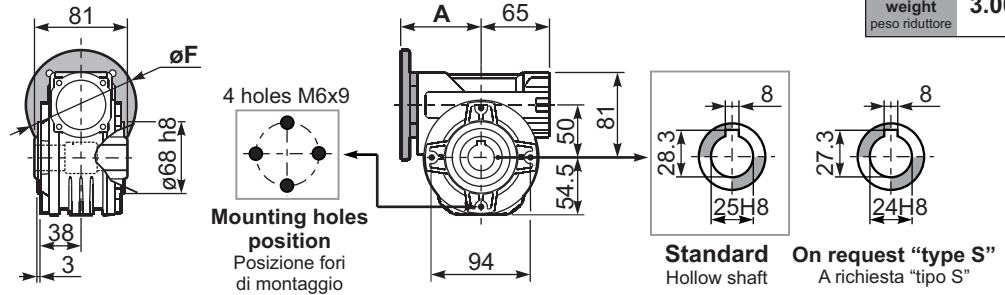

P050PA... Feet
Piedini

P050PB... Feet
Piedini

P050PV... Feet
Piedini

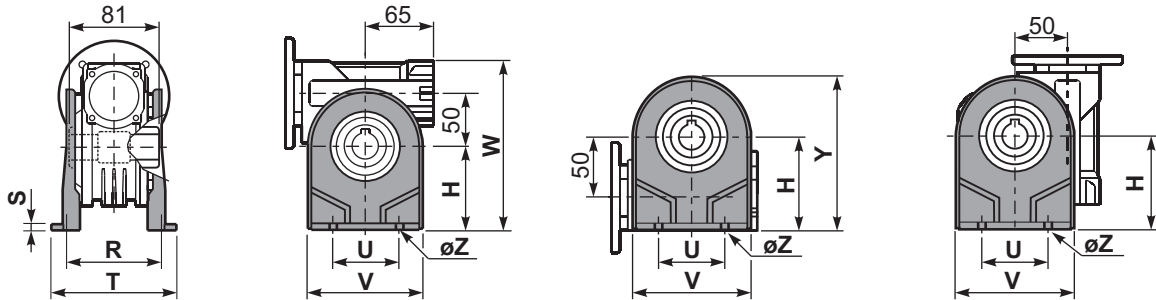

	H	R	S	T	U	V	Y	W	øZ	kit code
type B	82	98.5	3.5	123	63	113	138.5	163	ø10.5	K050.9.022
type S	85	96	10	114	85	110	139.5	166	ø10	KS050.9.023

P050FC... Output flange
Flangia uscita

P050BR... Reaction arm
Braccio di reazione

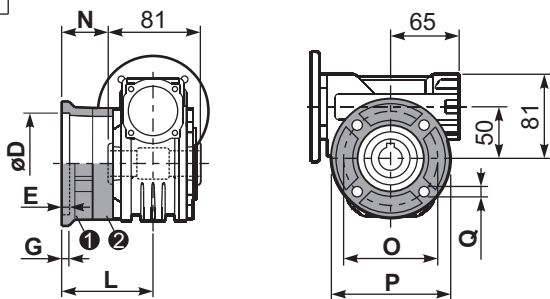

type B	øD	E	G	L	N	O	P	Q	kit code
FC	70 ^{+0.20} / _{+0.15}	9	12	85	44.5	90	123	10.5	① K050.9.010 ② -
FL	70 ^{+0.20} / _{+0.15}	9	12	114.5	74	90	123	10.5	① K050.9.010 ② K050.0.200
type S	øD	E	G	L	N	O	P	Q	kit code
F1	110 ^{+0.20} / _{+0.15}	4	11	83.5	43	130	160	10	① KS050.9.012 ② -
F2	70 ^{+0.20} / _{+0.15}	9	12	76.5	36	90	123	10.5	① KS050.9.014 ② -
F3	95 ^{+0.20} / _{+0.15}	4	10	66.5	26	115	140	10	① KS050.9.013 ② -

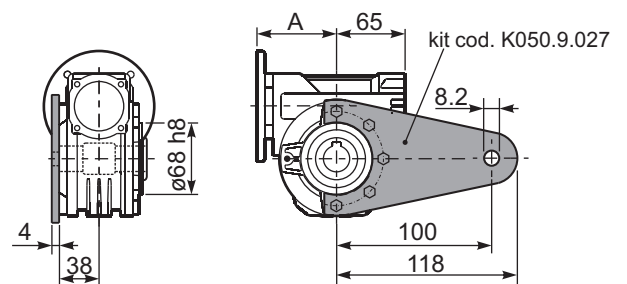

P050.....S... Single Shaft
Albero lento semplice

P050.....D... Double Shaft
Albero lento bisp.

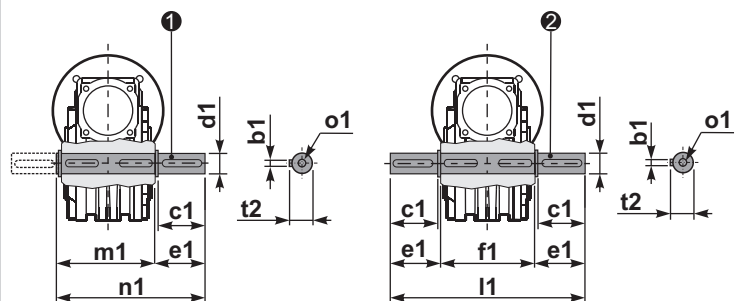

① kit cod. K050.5.028 type B
kit cod. KS050.5.030 type S

② kit cod. K050.5.029 type B
kit cod. KS050.5.031 type S

R050FB... Input shaft
Albero in entrata

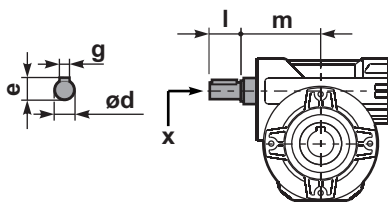

	ød	e	g	l	m	x	kit code
type B	16 h6	18	5	30	74.5	M6x16	① K050.5.006 PAM71 ② K050.5.007 PAM80
type S	14 h6	16	5	30	74.5	M5x10	① KS050.5.008 PAM71 ② KS050.5.009 PAM80

	b1	c1	d1	e1	f1	l1	m1	n1	t2	o1
type B	8	52	25 ^{-0.005} / _{-0.020}	59.5	81	200	86.5	146	28	M8x20
type S	8	50	24 ^{-0.005} / _{-0.020}	68.8	81	218	86.5	155	27	M8x20



QUICK SELECTION / Selezione veloce

input speed (n_1) = 1400 min⁻¹

Output Speed n_2 [min ⁻¹]	Ratio i	Motor power P_{1M} [kW]	Output torque M_{2M} [Nm]	Service factor f.s.	Nominal power P_{1R} [kW]	Nominal torque M_{2R} [Nm]	Available B5 motor flanges				Available B14 motor flanges			Dynamic efficiency RD	Tooth Module [mm]	Ratios code 	
							B	C	D	E	Q	R	T				
							63	71	80	90	71	80	90				
200	7	1.8	71	1.8	3.2	125		B	B			B-C	B-C		83	3.1	01
140	10	1.8	99	1.4	2.4	134		B	B			B-C	B-C		81	3.1	02
93	15	1.5	121	1.1	1.7	138		B	B			B-C	B-C		79	3.1	03
74	19	1.1	111	1.2	1.4	138		B	B			B-C	B-C		78	2.6	04
58	24	1.1	135	1.0	1.2	142		B	B			B-C	B-C		75	2.0	05
47	30	1.1	167	0.9	0.96	146		B	B			B-C	B-C		74	3.2	06
39	36	0.75	125	1.2	0.88	147		B	B	B		B-C	B-C		68	2.7	07
31	45	0.55	111	1.2	0.67	135	B	B				B-C	C		66	2.1	08
23	60	0.55	140	0.9	0.51	130	B	B				B-C	C		62	1.6	12
21	67	0.55	151	0.8	0.45	124	B	B				B-C	C		60	1.5	09
17.5	80	0.37	115	1.0	0.38	119	B	B				B-C	C		57	1.3	10
14.9	94	0.37	123	1.0	0.36	119	B	B				B-C	C		52	1.1	11

Motor Flanges Available
Flange Motore Disponibili

B) Supplied with Reduction Bushing
Fornito con Bussola di Riduzione

B) Available on Request without reduction bushing
Disponibile a Richiesta senza Bussola di Riduzione

C) Motor Flange Holes Position
Posizione Fori Flangia Motore

EN Unit **063** is supplied with synthetic oil, providing "long life" lubrication. For mounting position V5-V6 please contact us. See table 1 for lubrication and recommended quantity. In table 2 please see possible radial loads and axial loads on the gearbox.

I Il riduttore tipo **063** viene fornito lubrificato a vita con olio sintetico. Per posizioni V5-V6 contattare il ns. servizio tecnico. Vedi tab.1 per oli e quantità consigliati. In tab.2 sono presenti i carichi radiali e assiali applicabili al riduttore.

D Für die Lebensdauerschmierung ist das Getriebe der Größe **063** mit synthetischem Öl befüllt. Bei Einbaulage V5 oder V6 bitten wir um Rücksprache. In Tabelle 1 ist die Schmiermenge und das empfohlene Schmiermittel angegeben. In Tabelle 2 sind die zulässigen Radial- und Axialbelastungen des Getriebes aufgeführt.

F Le réducteur de type **063** est fourni lubrifié à vie avec de l'huile synthétique. Concernant les positions V5.V6, contactez notre service d'assistance technique. Voir tableau 1 concernant les huiles et les quantités conseillées. Les charges radiales et axiales applicables au réducteur sont précisées dans le tableau 2.

E El reductor tamaño **063** se suministra, lubricado de por vida con aceite sintético. Para las posiciones V5 y V6 contactar con nuestro servicio técnico. Ver tabla 1, para cantidades y aceites recomendados. En la tabla 2, se encuentran las cargas radiales y axiales admitidas por el reductor.

LUBRICATION 063 Oil Quantity 0.40 Lt.

AGIP Telium VSF 320

SHELL Omala S4 WE 320

For all details on lubrication and plugs check our website **tab. 1**
Per maggiori dettagli su lubrificazione e tappi olio vedi il nostro sito web

RADIAL AND AXIAL LOADS

Output shaft

Albero di uscita

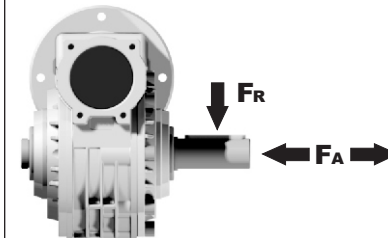

n_2 [min ⁻¹]	FA [N]	FR [N]
200	360	1800
150	400	2000
100	460	2300
75	500	2500
50	600	3000
25	700	3800
15	800	4000

Input shaft

albero in entrata

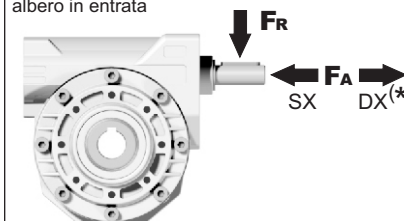

n_1 [min ⁻¹]	FA [N]	FR [N]
1400	90	450

***Strong axial loads in the DX direction are not allowed.**
Non sono consentiti forti carichi assiali con direzione DX

tab. 2

P063FB... Basic wormbox
Riduttore base

Gearbox weight
peso riduttore **6.00 kg**

M. flanges	Kit code	øF	A
63B5	K063.4.041	140	99.5
71B5	K063.4.042	160	97.5
80/90B5	K063.4.043	200	99.5
71B14	K063.4.047	105	97.5
80B14	K063.4.046	120	99.5
90B14	K063.4.041	140	99.5

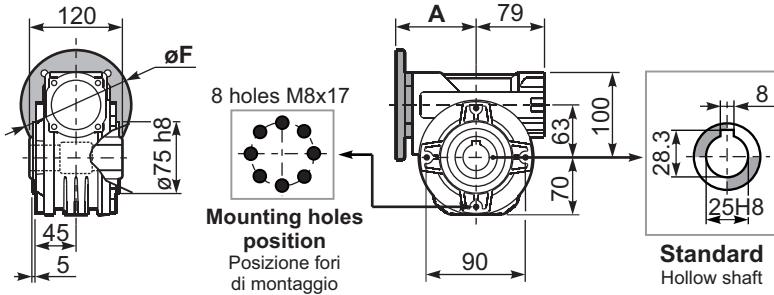

P063PA... Feet
Piedini

P063PB... Feet
Piedini

P063PV... Feet
Piedini

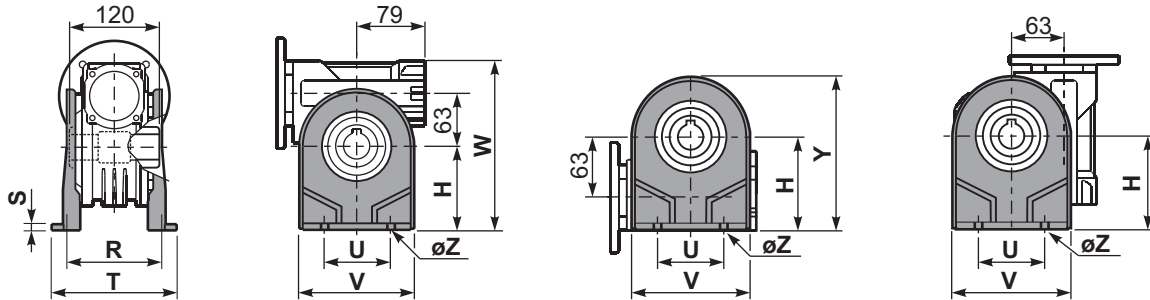

	H	R	S	T	U	V	Y	W	øZ	kit code
type B	100	111	4	144	95	133	170	200	ø10.5	K063.9.022
type S	-	-	-	-	-	-	-	-	-	-

P063FC... Output flange
Flangia uscita

P063BR... Reaction arm
Braccio di reazione

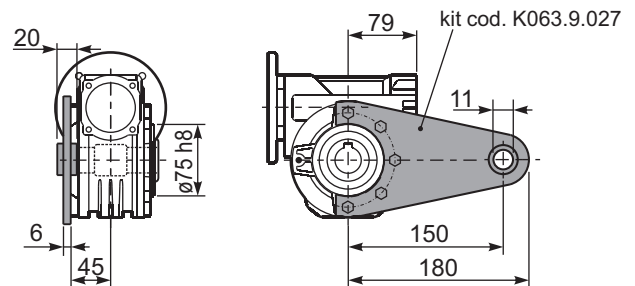
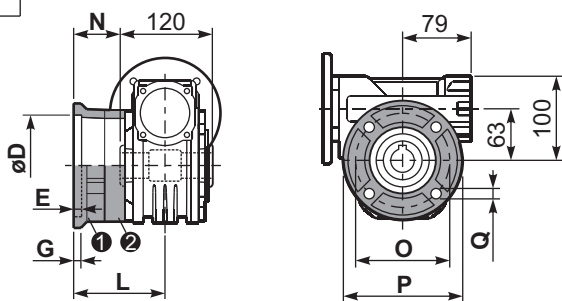

type B	øD	E	G	L	N	O	P	Q	kit code
FC	115 ^{+0.20} / _{+0.15}	7	13	86	26	150	175	11	① K063.9.010 ② -
FL	115 ^{+0.20} / _{+0.15}	7	13	116	56	150	175	11	① K063.9.010 ② K063.0.200

type S	øD	E	G	L	N	O	P	Q	kit code
F1	130 ^{+0.20} / _{+0.15}	7	13	102	42	165	200	13	① KS070.9.013 ② -
F2	115 ^{+0.20} / _{+0.15}	7	13	116	56	150	175	11	① KS063.9.013 ② -
F3	110 ^{+0.035} / ₀	5	11	82	22	130	160	10	① KS063.9.011 ② -

P063.....S... Single Shaft
Albero lento semplice

P063.....D... Double Shaft
Albero lento bisp.

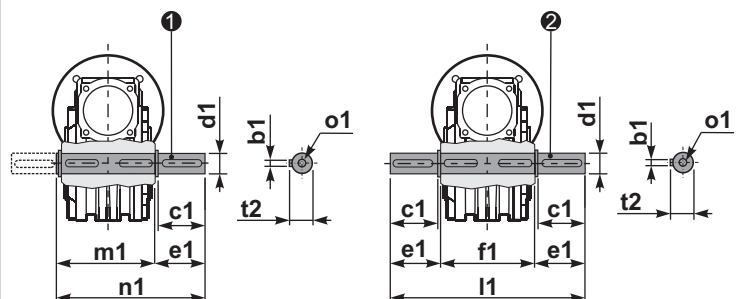

① kit cod. K063.5.028 type B

② kit cod. K063.5.029 type B

R063FB... Input shaft
Albero in entrata

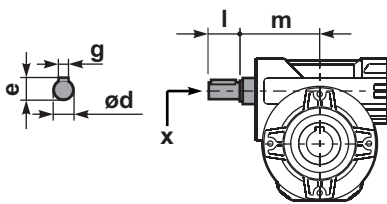

	ød	e	g	l	m	x	kit code
type B	18 h6	20.5	6	45	93	M6x16	① K063.5.006 PAM80 ② K063.5.007 PAM90
type S	19 h6	21.5	6	40	93	M8x20	① KS063.5.008 PAM80 ② KS063.5.009 PAM90

	b1	c1	d1	e1	f1	l1	m1	n1	t2	o1
type B	8	60	25 ^{-0.005} / _{-0.020}	63.2	120	246.4	126.8	190	28	M8x20
type S	-	-	-	-	-	-	-	-	-	-

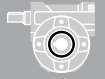

QUICK SELECTION / Selezione veloce

input speed (n_1) = 1400 min⁻¹

Output Speed n_2 [min ⁻¹]	Ratio i	Motor power P_{1M} [kW]	Output torque M_{2M} [Nm]	Service factor f.s.	Nominal power P_{1R} [kW]	Nominal torque M_{2R} [Nm]	Available B5 motor flanges				Available B14 motor flanges			Dynamic efficiency RD	Tooth Module [mm]	Ratios code 	
							B	C	D	E	Q	R	T				
							63	71	80	90	71	80	90				
200	7	1.8	71	2.3	4.1	162		B	B			B-C	B-C		83	3.1	01
140	10	1.8	99	1.7	3.1	173		B	B			B-C	B-C		81	3.1	02
93	15	1.5	121	1.5	2.2	178		B	B			B-C	B-C		79	3.1	03
74	19	1.5	152	1.2	1.8	178		B	B			B-C	B-C		78	2.6	04
58	24	1.5	184	1.0	1.5	185		B	B			B-C	B-C		75	2.0	05
47	30	1.5	227	0.8	1.3	189		B	B			B-C	B-C		74	3.2	06
39	36	1.1	184	1.0	1.1	191		B	B	B		B-C	B-C		68	2.7	07
31	45	0.75	152	1.2	0.86	175	B	B				B-C	C		66	2.1	08
23	60	0.55	140	1.2	0.66	168	B	B				B-C	C		62	1.6	12
21	67	0.55	151	1.1	0.58	159	B	B				B-C	C		60	1.5	09
17.5	80	0.37	115	1.3	0.49	153	B	B				B-C	C		57	1.3	10
14.9	94	0.37	123	1.1	0.39	130	B	B				B-C	C		52	1.1	11

Motor Flanges Available
Flange Motore Disponibili

B) Supplied with Reduction Bushing
Fornito con Bussola di Riduzione

B) Available on Request without reduction bushing
Disponibile a Richiesta senza Bussola di Riduzione

C) Motor Flange Holes Position
Posizione Fori Flangia Motore

EN Unit **63A** is supplied with synthetic oil, providing "long life" lubrication. For mounting position V5-V6 please contact us. See table 1 for lubrication and recommended quantity. In table 2 please see possible radial loads and axial loads on the gearbox.

I Il riduttore tipo **63A** viene fornito lubrificato a vita con olio sintetico. Per posizioni V5-V6 contattare il ns. servizio tecnico. Vedi tab.1 per oli e quantità consigliati. In tab.2 sono presenti i carichi radiali e assiali applicabili al riduttore.

D Für die Lebensdauerschmierung ist das Getriebe der Größe **63A** mit synthetischem Öl befüllt. Bei Einbaulage V5 oder V6 bitten wir um Rücksprache. In Tabelle 1 ist die Schmiermenge und das empfohlene Schmiermittel angegeben. In Tabelle 2 sind die zulässigen Radial- und Axialbelastungen des Getriebes aufgeführt.

F Le réducteur de type **63A** est fourni lubrifié à vie avec de l'huile synthétique. Concernant les positions V5.V6, contactez notre service d'assistance technique. Voir tableau 1 concernant les huiles et les quantités conseillées. Les charges radiales et axiales applicables au réducteur sont précisées dans le tableau 2.

E El reductor tamaño **63A** se suministra, lubricado de por vida con aceite sintético. Para las posiciones V5 y V6 contactar con nuestro servicio técnico. Ver tabla 1, para cantidades y aceites recomendados. En la tabla 2, se encuentran las cargas radiales y axiales admitidas por el reductor.

LUBRICATION 63A Oil Quantity 0.40 Lt.

AGIP Telium VSF 320

SHELL Omala S4 WE 320

For all details on lubrication and plugs check our website **tab. 1**
Per maggiori dettagli su lubrificazione e tappi olio vedi il nostro sito web

RADIAL AND AXIAL LOADS

Output shaft

Albero di uscita

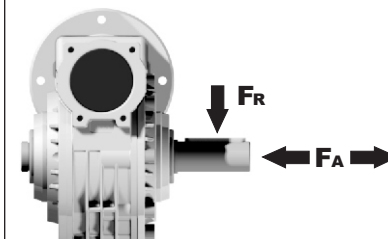

n_2 [min ⁻¹]	FA [N]	FR [N]
200	360	1800
150	400	2000
100	460	2300
75	500	2500
50	600	3000
25	700	3800
15	800	4000

Input shaft

albero in entrata

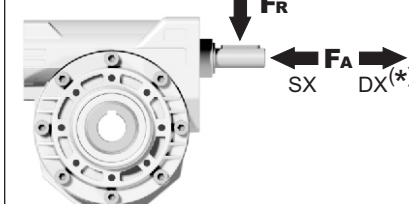

n_1 [min ⁻¹]	FA [N]	FR [N]
1400	90	450

***Strong axial loads in the DX direction are not allowed.**
Non sono consentiti forti carichi assiali con direzione DX

tab. 2

P63AFB... Basic wormbox
Riduttore base

Gearbox weight
peso riduttore **6.00 kg**

M. flanges	Kit code	øF	A
63B5	K063.4.041	140	99.5
71B5	K063.4.042	160	97.5
80/90B5	K063.4.043	200	99.5
71B14	K063.4.047	105	97.5
80B14	K063.4.046	120	99.5
90B14	K063.4.041	140	99.5

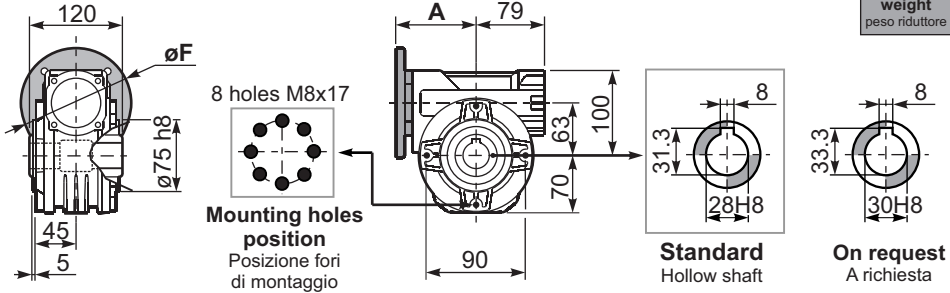

P63APA... Feet
Piedini

P63APB... Feet
Piedini

P63APV... Feet
Piedini

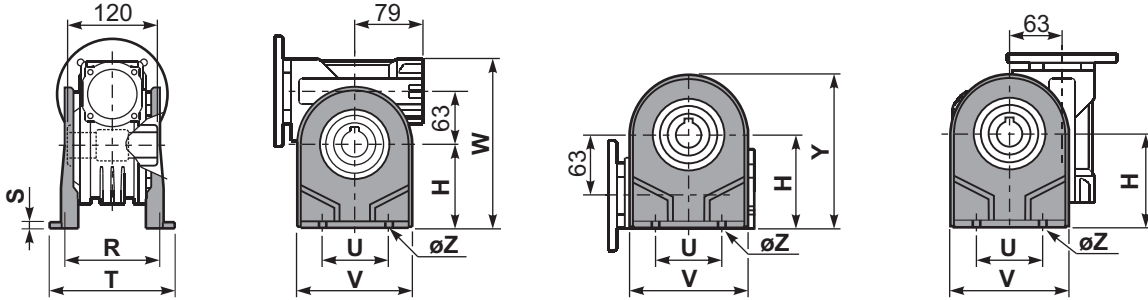

	H	R	S	T	U	V	Y	W	øZ	kit code
type B	115	115	12	142	120	156	185	215	ø11	K070.9.022
type S	-	-	-	-	-	-	-	-	-	-

P63AFC... Output flange
Flangia uscita

P63ABR... Reaction arm
Braccio di reazione

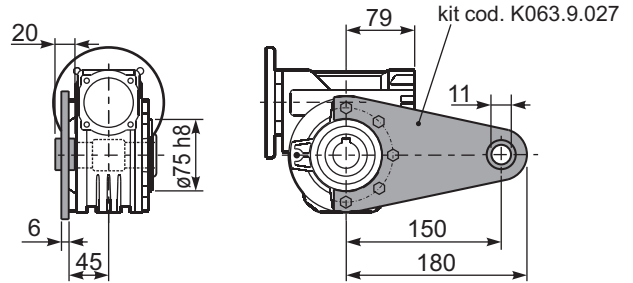
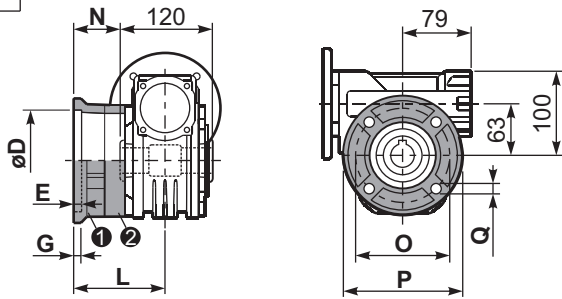

type B	øD	E	G	L	N	O	P	Q	kit code
FC	130 ^{+0.20} / _{+0.15}	7	13	85	25	165	200	13	① K070.9.010 ② -
FL	130 ^{+0.20} / _{+0.15}	7	13	111	51	165	200	13	① K070.9.010 ② K070.0.200
type S	øD	E	G	L	N	O	P	Q	kit code
F1	130 ^{+0.20} / _{+0.15}	7	13	111	51	165	200	13	① KS070.9.014 ② -
F2	115 ^{+0.20} / _{+0.15}	7	13	116	56	150	175	11	① KS063.9.013 ② -
F3	110 ^{+0.035} / ₀	5	13.5	84.5	24.5	130	160	11	① KS070.9.011 ② -

P63A.....S... Single Shaft
Albero lento semplice

P63A.....D... Double Shaft
Albero lento bisp.

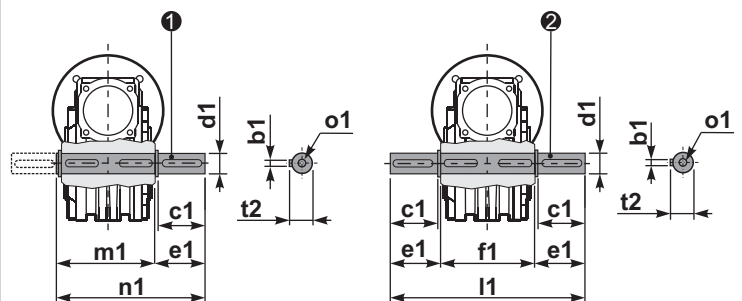

① kit cod. K070.5.028 type B

② kit cod. K070.5.029 type B

R63AFB... Input shaft
Albero in entrata

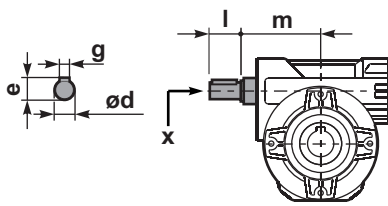

	ød	e	g	l	m	x	kit code
type B	18 h6	20.5	6	45	93	M6x16	① K063.5.006 PAM80 ② K063.5.007 PAM90
type S	19 h6	21.5	6	40	93	M8x20	① KS063.5.008 PAM80 ② KS063.5.009 PAM90

	b1	c1	d1	e1	f1	l1	m1	n1	t2	o1
type B	8	60	28 ^{-0.005} / _{-0.020}	63.5	120	247	127.5	191	31	M8x20
type S	-	-	-	-	-	-	-	-	-	-

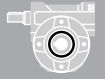

QUICK SELECTION / Selezione veloce

input speed (n_1) = 1400 min⁻¹

Output Speed n_2 [min ⁻¹]	Ratio i	Motor power P_{1M} [kW]	Output torque M_{2M} [Nm]	Service factor f.s.	Nominal power P_{1R} [kW]	Nominal torque M_{2R} [Nm]	Available B5 motor flanges				Available B14 motor flanges			Dynamic efficiency RD	Tooth Module [mm]	Ratios code	
							C	D	E	F	R	T	U				
							71	80	90	100 112	80	90	100 112				
200	7	4.0	168	1.5	6.1	257		B	B			B	B		88	4.23	01
140	10	4.0	218	1.3	5.2	284		B	B			B	B		80	4.2	02
100	14	3.0	223	1.4	4.1	305		B	B			B	B		78	4.5	03
70	20	2.2	237	1.2	2.7	294		B	B			B	B		79	3.4	04
64	22	2.2	258	1.1	2.5	294		B	B			B	B		78	3.1	05
50	28	2.2	315	1.1	2.4	347		B	B	B		B	B		75	4.7	06
37	38	1.5	276	1.2	1.8	336	B	B				B			71	3.5	07
30	46	1.5	320	1.0	1.5	326	B	B				B			68	3.1	08
27	52	1.1	258	1.1	1.2	289	B	B				B			66	2.7	09
21	67	1.1	327	0.9	0.97	289	B	B				B			65	2.1	10
18.9	74	0.75	220	1.2	0.91	268	B	B				B			58	1.9	11
14.6	96	0.55	191	1.3	0.70	242	B	B				B			53	1.5	12

Motor Flanges Available Flange Motore Disponibili
 B Supplied with Reduction Bushing Fornito con Bussola di Riduzione
 B Available on Request without reduction bushing Disponibile a Richiesta senza Bussola di Riduzione
 C Motor Flange Holes Position Posizione Fori Flangia Motore

EN Unit 085 is supplied with synthetic oil, providing "long life" lubrication. For mounting position V5-V6 please contact us. See table 1 for lubrication and recommended quantity. In table 2 please see possible radial loads and axial loads on the gearbox.

I Il riduttore tipo 085 viene fornito lubrificato a vita con olio sintetico. Per posizioni V5-V6 contattare il ns. servizio tecnico. Vedi tab.1 per oli e quantità consigliati. In tab.2 sono presenti i carichi radiali e assiali applicabili al riduttore.

D Für die Lebensdauerschmierung ist das Getriebe der Größe 085 mit synthetischem Öl befüllt. Bei Einbaulage V5 oder V6 bitten wir um Rücksprache. In Tabelle 1 ist die Schmiermenge und das empfohlene Schmiermittel angegeben. In Tabelle 2 sind die zulässigen Radial- und Axialbelastungen des Getriebes aufgeführt.

F Le réducteur de type 085 est fourni lubrifié à vie avec de l'huile synthétique. Concernant les positions V5.V6, contactez notre service d'assistance technique. Voir tableau 1 concernant les huiles et les quantités conseillées. Les charges radiales et axiales applicables au réducteur sont précisées dans le tableau 2.

E El reductor tamaño 085 se suministra, lubricado de por vida con aceite sintético. Para las posiciones V5 y V6 contactar con nuestro servicio técnico. Ver tabla 1, para cantidades y aceites recomendados. En la tabla 2, se encuentran las cargas radiales y axiales admitidas por el reductor.

LUBRICATION 085 Oil Quantity 1.20 Lt.

AGIP Telium VSF 320	SHELL Omala S4 WE 320
----------------------------	------------------------------

For all details on lubrication and plugs check our website tab. 1
Per maggiori dettagli su lubrificazione e tappi olio vedi il nostro sito web

RADIAL AND AXIAL LOADS

Output shaft
Albero di uscita

n_2 [min ⁻¹]	FA [N]	FR [N]
200	500	2500
150	580	2900
100	600	3000
75	700	3500
50	800	4000
25	1000	5000
15	1160	5800

Input shaft
albero in entrata

n_1 [min ⁻¹]	FA [N]	FR [N]
1400	160	809

***Strong axial loads in the DX direction are not allowed.**
Non sono consentiti forti carichi assiali con direzione DX

tab. 2

P085FB... Basic wormbox
Riduttore base

Gearbox weight
peso riduttore **11.00 kg**

M. flanges	Kit code	øF	A
71B5	K023.4.041	160	116
80/90B5	K023.4.042	200	118
100/112B5	K023.4.043	250	127
80B14	K085.4.046	120	118
90B14	K085.4.045	140	118
100/112B14	K023.4.041	160	116

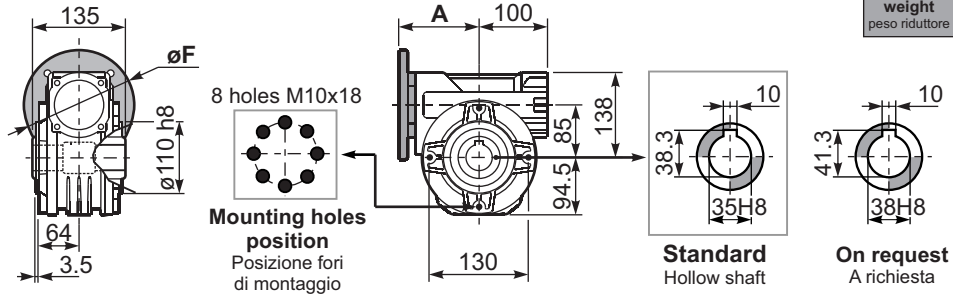

P085PA... Feet
Piedini

P085PB... Feet
Piedini

P085PV... Feet
Piedini

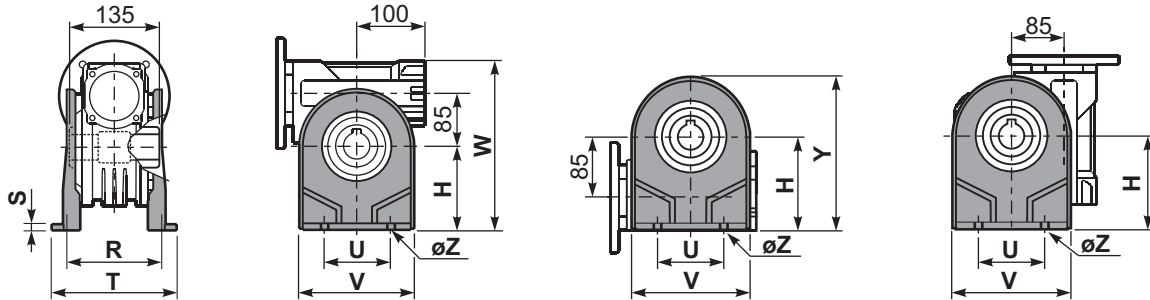

	H	R	S	T	U	V	Y	W	øZ	kit code
type B	142	145	5	182	140	180	236.5	280	ø10.5	K085.9.022
type S	-	-	-	-	-	-	-	-	-	-

P085FC... Output flange
Flangia uscita

P085BR... Reaction arm
Braccio di reazione

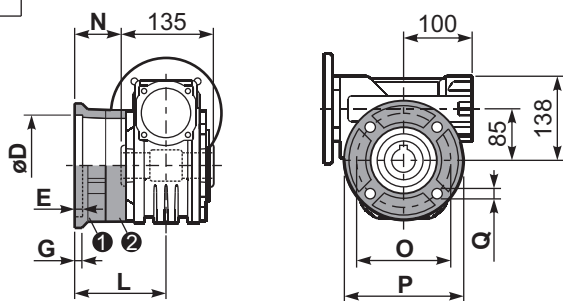

type B	øD	E	G	L	N	O	P	Q	kit code
FC	152 ^{+0.06} / _{+0.00}	5	16	108	40.5	176	205	13	① K085.9.010 ② -
FL	152 ^{+0.06} / _{+0.00}	5	16	148.5	81	176	205	13	① K085.9.010 ② K085.0.201
type S	øD	E	G	L	N	O	P	Q	kit code
F1	130 H7	5	13	117.5	50	165	200	11.5	① KS085.9.012 ② -
F2	152 ^{+0.06} / _{+0.00}	5	15	147.5	80	180	205	12.5	① KS085.9.013 ② -
F4	130 H7	5	13	106.5	39	165	200	13	① KS085.9.015 ② -

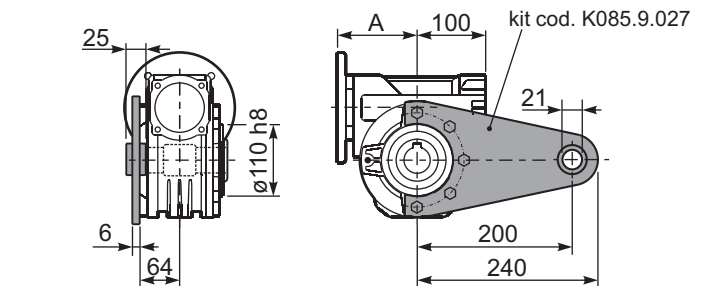

P085.....S... Single Shaft
Albero lento semplice

P085.....D... Double Shaft
Albero lento bisp.

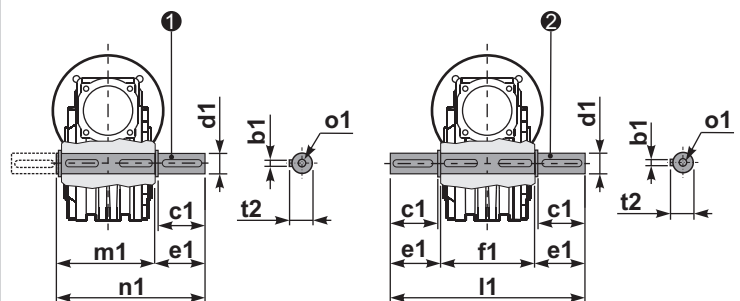

① kit cod. K085.5.028 type B

② kit cod. K085.5.029 type B

R085FB... Input shaft
Albero in entrata

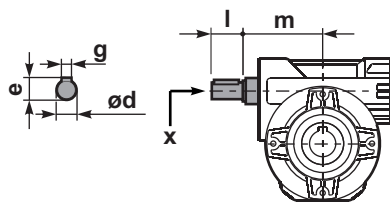

	ød	e	g	l	m	x	kit code
type B	25 h6	28	8	50	112	M8x20	① K085.5.007 PAM90 ② K085.5.008 PAM100
type S	24 h6	27	8	50	112	M8x20	① KS085.5.009 PAM90 ② KS085.5.011 PAM100

	b1	c1	d1	e1	f1	l1	m1	n1	t2	o1
type B	10	60	35 ^{-0.005} / _{-0.020}	73.5	135	282	141	214.5	38	M10x23
type S	-	-	-	-	-	-	-	-	-	-



QUICK SELECTION / Selezione veloce

input speed (n_1) = 1400 min⁻¹

Output Speed n_2 [min ⁻¹]	Ratio i	Motor power P_{1M} [kW]	Output torque M_{2M} [Nm]	Service factor f.s.	Nominal power P_{1R} [kW]	Nominal torque M_{2R} [Nm]	Available B5 motor flanges					Available B14 motor flanges				Dynamic efficiency RD	Tooth Module [mm]	Ratios code	
							C	D	E	F	G	R	T	U	V				
							71	80	90	100 112	132	80	90	100 112	132				
200	7	7.5	315	1.5	11.5	483		B	B				B	B			88	5.5	01
140	10	7.5	440	1.2	9.0	525		B	B				B	B			86	5.4	02
88	16	5.5	492	1.1	6.0	536		B	B				B	B			82	5.3	03
70	20	4.0	447	1.2	4.9	546		B	B				B	B			82	4.5	04
61	23	3.0	377	1.4	4.1	515		B	B				B	B			80	3.9	05
47	30	3.0	467	1.4	4.2	651		B	B				B	B			76	5.6	06
37	38	3.0	583	1.1	3.3	641		B	B				B	B			75	4.7	07
31	45	2.2	493	1.2	2.7	599		B	B				B	B			73	4.0	08
26	53	2.2	557	1.1	2.5	620		B	B				B	B			70	3.5	09
22	64	1.5	452	1.2	1.8	536	B	B					B				69	2.9	10
16.7	84	1.1	410	1.2	1.3	494	B	B					B				65	2.2	11
14.1	99	1.1	446	1.1	1.2	483	B	B					B				60	1.9	12

 Motor Flanges Available Flange Motore Disponibili
 B) Supplied with Reduction Bushing Fornito con Bussola di Riduzione
 B) Available on Request without reduction bushing Disponibile a Richiesta senza Bussola di Riduzione
 C) Motor Flange Holes Position Posizione Fori Flangia Motore

EN Unit 110 is supplied without lubricant and equipped with a breather, level and drain plugs. User can add mineral oil keeping existing plugs. Should the user wish to fill it with synthetic oil, it is recommended to replace the existing plugs with a closed plug. See table 1 for lubrication and recommended quantity. In table 2 please see possible radial loads and axial loads on the gearbox.

I Il riduttore tipo 110 è fornito privo di lubrificazione con tappi di sfiato, livello e scarico olio. L'utente può immettere olio minerale mantenendo i tappi esistenti. Se immetterà olio sintetico, dovrà sostituire i tappi esistenti con altri tipo chiuso. Tab.1 per oli e quantità consigliati. Tab.2 carichi radiali e assiali applicabili al riduttore.

D Das Getriebe der Baugröße 110 wird ohne Schmiermittel geliefert. Es ist jedoch mit Einfüllschraube, Überdruckventil und Ablassschraube ausgerüstet. Das benötigte mineralische Öl kann über die Einfüllschraube eingefüllt werden. Sollte synthetisches Öl bevorzugt werden, so ist sind das eingebaute Überdruckventil durch eine geschlossenen Schraube zu ersetzen. In Tabelle 1 ist die Schmiermenge und das empfohlene Schmiermittel angegeben. In Tabelle 2 sind die zulässigen Radial - und Axialbelastungen des Getriebes aufgeführt.

F Le réducteur de type 110 est fourni sans lubrification et avec un bouchon de remplissage, de niveau et d'évacuation de l'huile. L'utilisateur peut y verser de l'huile minérale en conservant les bouchons existants. S'il y versera de l'huile synthétique, il devra substituer les bouchons existants avec d'autres bouchons de type fermé. Voir tableau 1 concernant les huiles et les quantités conseillées. Voir tableau 2 concernant les charges radiales et axiales applicables au réducteur.

E El reductor tamaño 110 se suministra sin lubricante, provisto de tapones de respiración, nivel y descarga de aceite. El usuario puede utilizar aceite mineral, manteniendo los tapones existentes. Si prefiere utilizar aceite sintético deberá sustituir los tapones existentes por tapones ciegos. La prerreducción se suministra con tapones ciegos, lubricado de por vida con aceite sintético. Ver tabla 1, para cantidades y aceites recomendados. En la tabla 2, se encuentran las cargas radiales y axiales admitidas por el reductor.

B3	B6	B7	B8	V5	V6
2.00 LT	1.50 LT	1.50 LT	2.00LT	2.00 LT	2.00LT

AGIP Blasias 460

For all details on lubrication and plugs check our website [www.agip.com](#) Per maggiori dettagli su lubrificazione e tappi olio vedi il nostro sito web [www.agip.com](#) **tab. 1**

RADIAL AND AXIAL LOADS

Output shaft
Albero di uscita

n_2 [min ⁻¹]	FA [N]	FR [N]
200	600	2900
150	700	3300
100	750	3600
75	800	4000
50	920	4600
25	1200	6000
15	1400	7000

Input shaft
albero in entrata

n_1 [min ⁻¹]	FA [N]	FR [N]
1400	228	1140

***Strong axial loads in the DX direction are not allowed.**
Non sono consentiti forti carichi assiali con direzione DX

tab. 2

P110FB... Basic wormbox
Riduttore base

Gearbox weight
peso riduttore **35.00 kg**

M. flanges	Kit code	øF	A
71B5	K023.4.041	160	135.5
80/90B5	K023.4.042	200	137.5
100/112B5	K023.4.043	250	146.5
132B5	-	300	187
80B14	K085.4.046	120	137.5
90B14	K085.4.045	140	137.5
100/112B14	K023.4.041	160	135.5
132B14	-	200	187

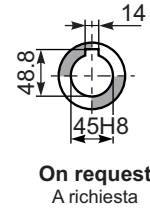
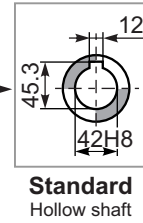
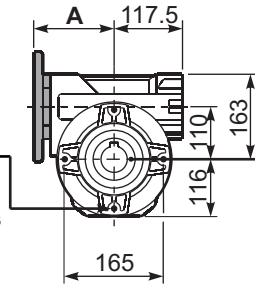
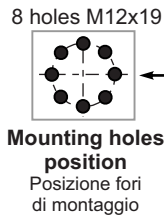
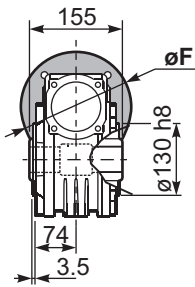

P110PA... Feet
Piedini

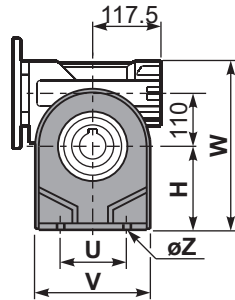
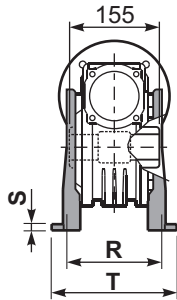

P110PB... Feet
Piedini

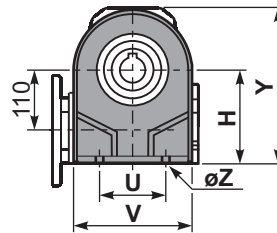

P110PV... Feet
Piedini

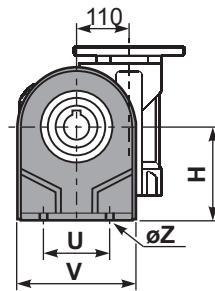

	H	R	S	T	U	V	Y	W	øZ	kit code
type B	170	180	22	224	200	240	286	333	ø13	K110.9.022
type S	172	160	18	190	200	240	288	335	ø14	KS110.9.023

P110FC... Output flange
Flangia uscita

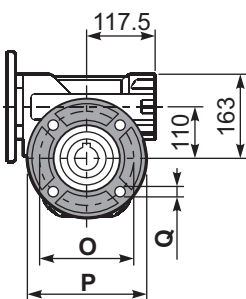
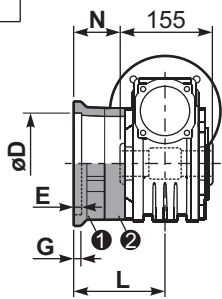

type B	øD	E	G	L	N	O	P	Q	kit code
FC	170 ^{+0.083} / _{-0.043}	11	16.5	131.5	54	230	270	13	1 K110.9.010 2 -
FL	170 ^{+0.083} / _{-0.043}	11	16.5	179.5	102	230	270	13	1 K110.9.011 2 -
type S	øD	E	G	L	N	O	P	Q	kit code
F1	180 ^{+0.040} / ₀	5	18	150	72.5	215	250	15	1 KS110.9.014 2 -
F2	170 ^{+0.083} / _{-0.043}	9.5	15	178	100.5	230	270	13	1 KS110.9.012 2 -
F3	180 ^{+0.040} / ₀	5	18	130	52.5	215	250	15	1 KS110.9.013 2 -

P110BR... Reaction arm
Braccio di reazione

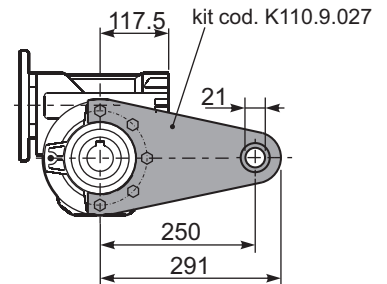
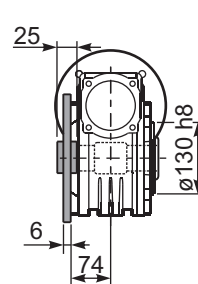

P110.....S... Single Shaft
Albero lento semplice

P110.....D... Double Shaft
Albero lento bisp.

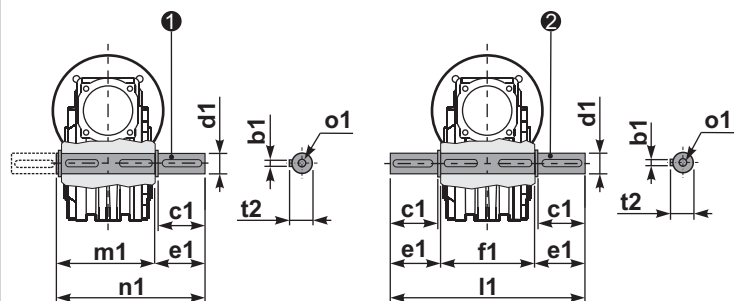

1 kit cod. K110.5.028 type B

2 kit cod. K110.5.029 type B

R110FB... Input shaft
Albero in entrata

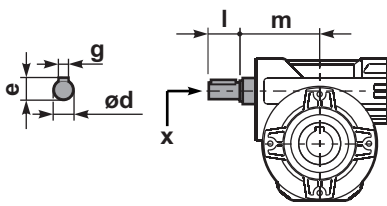

	ød	e	g	l	m	x	kit code
type B	25 h6	28	8	50	131.5	M8x20	1 K085.5.007 PAM90 2 K085.5.008 PAM100
type S	24 h6	27	8	50	131.5	M8x20	1 KS085.5.009 PAM90 2 KS085.5.011 PAM100

	b1	c1	d1	e1	f1	l1	m1	n1	t2	o1
type B	12	75	42 ^{-0.005} / _{-0.020}	96.5	155	348	163.5	260	45	M12x32
type S	-	-	-	-	-	-	-	-	-	-

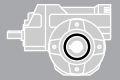

QUICK SELECTION / Selezione veloce

input speed (n_1) = 1400 min⁻¹

Output Speed n_2 [min ⁻¹]	Ratio i	Motor power P_{1M} [kW]	Output torque M_{2M} [Nm]	Service factor f.s.	Nominal power P_{1R} [kW]	Nominal torque M_{2R} [Nm]	Available B5 motor flanges			Available B14 motor flanges		Dynamic efficiency RD	Tooth Module [mm]	Ratios code
							A	B	C	P	Q			
							56	63	71	63	71			
47	30.1	0.25	38	1.4	0.36	55				C		74	2.2	01
33	43.0	0.25	53	1.0	0.26	55				C		72	2.2	02
23	60.2	0.25	62	0.9	0.22	55				C		60	2.4	03
15.5	90.3	0.12	42	1.3	0.16	55				C		57	1.6	04
11.6	120	0.12	52	1.1	0.13	55				C		53	2.5	05
8.8	159	0.12	64	0.9	0.10	55				C		49	1.8	06
7.1	198	0.12*	55	<0.8	0.09	55				C		47	1.5	07
5.4	258	0.12*	55	<0.8	0.07	55				C		45	1.2	08
4.7	301	0.12*	39	<0.8	0.05	39				C		40	1.0	09
3.2	439	0.12*	39	<0.8	0.04	39				C		36	0.72	10

A) Motor Flanges Available
Flange Motore Disponibili

B) Supplied with Reduction Bushing
Fornito con Bussola di Riduzione

Available on Request without reduction bushing
Disponibile a Richiesta senza Bussola di Riduzione

C) Motor Flange Holes Position
Posizione Fori Flangia Motore

* Power higher than the maximum one which can be supported by the gearbox. Select according to the torque M_{2R}
Potenza superiore a quella massima sopportabile dal riduttore. Selezionare in base al momento torcente M_{2R}

EN Unit **P45** is supplied with synthetic oil, providing "long life" lubrication. For mounting position V5-V6 please contact us. See table 1 for lubrication and recommended quantity. In table 2 please see possible radial loads and axial loads on the gearbox.

I Il riduttore tipo **P45** viene fornito lubrificato a vita con olio sintetico. Per posizioni V5-V6 contattare il ns. servizio tecnico. Vedi tab.1 per oli e quantità consigliati. In tab.2 sono presenti i carichi radiali e assiali applicabili al riduttore.

D Für die Lebensdauerschmierung ist das Getriebe der Größe **P45** mit synthetischem Öl befüllt. Bei Einbaulage V5 oder V6 bitten wir um Rücksprache. In Tabelle 1 ist die Schmiermenge und das empfohlene Schmiermittel angegeben. In Tabelle 2 sind die zulässigen Radial- und Axialbelastungen des Getriebes aufgeführt.

F Le réducteur de type **P45** est fourni lubrifié à vie avec de l'huile synthétique. Concernant les positions V5.V6, contactez notre service d'assistance technique. Voir tableau 1 concernant les huiles et les quantités conseillées. Les charges radiales et axiales applicables au réducteur sont précisées dans le tableau 2.

E El reductor tamaño **P45** se suministra, lubricado de por vida con aceite sintético. Para las posiciones V5 y V6 contactar con nuestro servicio técnico. Ver tabla 1, para cantidades y aceites recomendados. En la tabla 2, se encuentran las cargas radiales y axiales admitidas por el reductor.

LUBRICATION P45 Oil

Common lubrication 0.17 l (A + B).



AGIP Telium VSF 320

SHELL Omala S4 WE 320

For all details on lubrication and plugs check our website **tab. 1**
Per maggiori dettagli su lubrificazione e tappi olio vedi il nostro sito web

RADIAL AND AXIAL LOADS

Output shaft
Albero di uscita

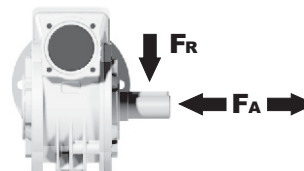

n_2 [min ⁻¹]	FA [N]	FR [N]
75	240	1200
50	260	1400
25	300	1800
15-6	400	2000

Input shaft
albero in entrata

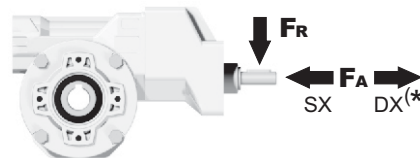

n_1 [min ⁻¹]	FA [N]	FR [N]
1400	44	220

*Strong axial loads in the DX direction are not allowed.
Non sono consentiti forti carichi assiali con direzione DX

tab. 2

PP45FB... Basic wormbox
Riduttore base

Gearbox weight
peso riduttore **3.20 kg**

M. flanges	Kit code	øF	A
56B5	K050.4.046	120	137.5
63B5	K050.4.041	138	139.5
71B5	K050.4.042	160	137
63B14	K050.4.047	90	139.5
71B14	K050.4.045	105	137

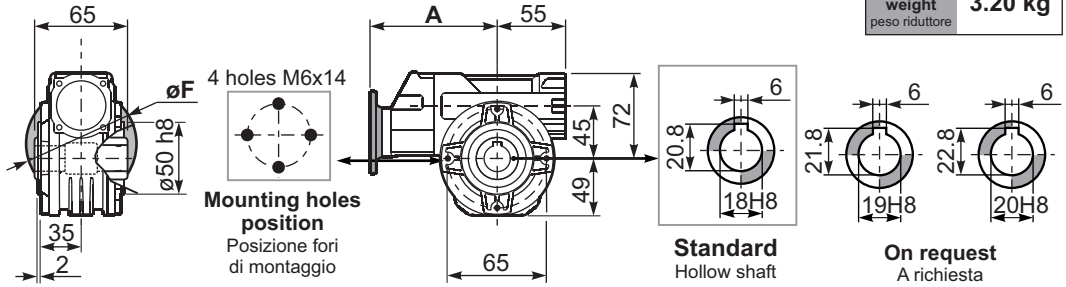

PP45PA... Feet
Piedini

PP45PB... Feet
Piedini

PP45PV... Feet
Piedini

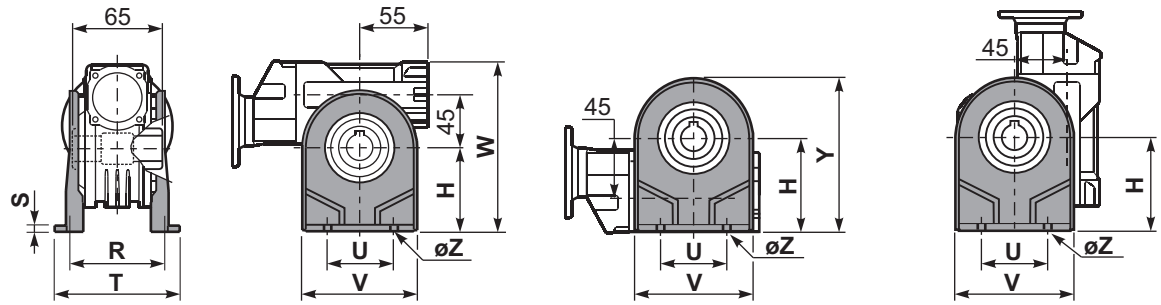

	H	R	S	T	U	V	Y	W	øZ	kit code
type B	72	81	3	100	52	98	121	144	ø10.5	K045.9.022
type S	71	84	8	100	70	90	120	143	ø8	KS045.9.023

PP45FC... Output flange
Flangia uscita

PP45BR... Reaction arm
Braccio di reazione

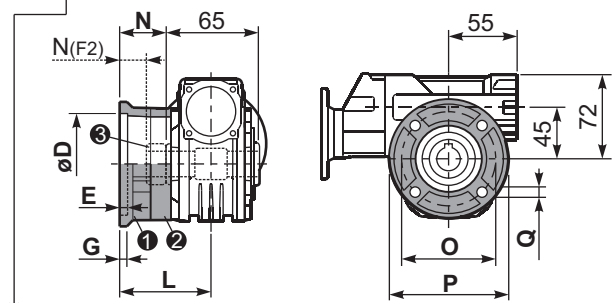

type B	øD	E	G	L	N	O	P	Q	kit code
FC	60 ^{+0.15} / _{-0.05}	9	9	60.5	28	87	110	8.5	① K045.9.010 ② -
FL	60 ^{+0.15} / _{-0.05}	9	9	90.5	58	87	110	8.5	① K045.9.010 ② K045.0.200

type S	øD	E	G	L	N	O	P	Q	kit code
F1	95 ^{+0.20} / _{-0.15}	4	11	73.5	41	115	140	9	① KS045.9.013 ② -
F2	60 ^{+0.15} / _{-0.05}	9	9	60.5	19	87	110	8.5	① KS045.9.010 ② S045.0.204
F3	80 ^{+0.03} / _{-0.00}	3	8	51.5	19	100	120	9	① KS045.9.014 ② -

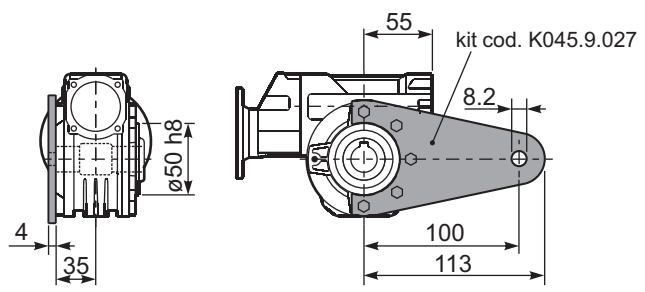

PP45.....S... Single Shaft
Albero lento semplice

PP45.....D... Double Shaft
Albero lento bisp.

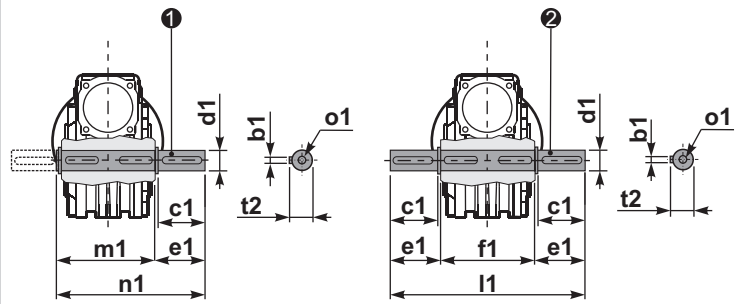

- ① kit cod. K045.5.028 type B
kit cod. KS045.5.030 type S
- ② kit cod. K045.5.029 type B
kit cod. KS045.5.031 type S

RP45FB... Input shaft
Albero in entrata

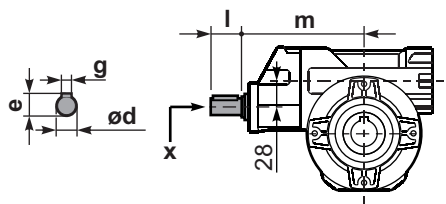

	ød	e	g	l	m	x
type B	14 h6	16	5	25	131	M5x13
type S	-	-	-	-	-	-

	b1	c1	d1	e1	f1	l1	m1	n1	t2	o1
type B	6	32	18 ^{-0.005} / _{-0.020}	43	65	151	70	113	20.5	M6x18
type S	6	40	19 ^{-0.005} / _{-0.020}	58.8	65	182	70	128.5	21.5	M8x20

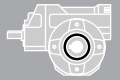

QUICK SELECTION / Selezione veloce

input speed (n_1) = 1400 min⁻¹

Output Speed n_2 [min ⁻¹]	Ratio i	Motor power P_{1M} [kW]	Output torque M_{2M} [Nm]	Service factor f.s.	Nominal power P_{1R} [kW]	Nominal torque M_{2R} [Nm]	Available B5 motor flanges			Available B14 motor flanges		Dynamic efficiency RD	Tooth Module [mm]	Ratios code
							A	B	C	P	Q			
							56	63	71	63	71			
47	30.1	0.37	58	1.3	0.49	77				C		76	2.5	01
33	43.0	0.25	55	1.4	0.35	77				C		75	2.4	02
23	60.2	0.25	71	1.1	0.27	77				C		69	2.6	03
18.1	77.4	0.25	81	1.1	0.27	88				C		61	2.0	04
12.5	112	0.18	84	1.1	0.19	88				C		61	2.7	05
9.0	155	0.12	71	1.2	0.15	88				C		56	2.1	06
7.6	185	0.12	74	1.0	0.12	77				C		49	1.8	07
5.4	258	0.12*	77	<0.8	0.09	77				C		47	1.3	08
4.8	292	0.12*	66	<0.8	0.08	66				C		44	1.2	09
4.1	344	0.12*	44	<0.8	0.05	44				C		40	1.0	10
3.3	430	0.12*	44	<0.8	0.04	44				C		36	0.8	11

Motor Flanges Available Flange Motore Disponibili
 B) Supplied with Reduction Bushing Fornito con Bussola di Riduzione
 B) Available on Request without reduction bushing Disponibile a Richiesta senza Bussola di Riduzione
 C) Motor Flange Holes Position Posizione Fori Flangia Motore

* Power higher than the maximum one which can be supported by the gearbox. Select according to the torque M_{2R}
 Potenza superiore a quella massima sopportabile dal riduttore. Selezionare in base al momento torcente M_{2R}

EN Unit P50 is supplied with synthetic oil, providing "long life" lubrication. For mounting position V5-V6 please contact us. See table 1 for lubrication and recommended quantity. In table 2 please see possible radial loads and axial loads on the gearbox.

I Il riduttore tipo P50 viene fornito lubrificato a vita con olio sintetico. Per posizioni V5-V6 contattare il ns. servizio tecnico. Vedi tab.1 per oli e quantità consigliati. In tab.2 sono presenti i carichi radiali e assiali applicabili al riduttore.

D Für die Lebensdauerschmierung ist das Getriebe der Größe P50 mit synthetischem Öl befüllt. Bei Einbaulage V5 oder V6 bitten wir um Rücksprache. In Tabelle 1 ist die Schmiermenge und das empfohlene Schmiermittel angegeben. In Tabelle 2 sind die zulässigen Radial- und Axialbelastungen des Getriebes aufgeführt.

F Le réducteur de type P50 est fourni lubrifié à vie avec de l'huile synthétique. Concernant les positions V5.V6, contactez notre service d'assistance technique. Voir tableau 1 concernant les huiles et les quantités conseillées. Les charges radiales et axiales applicables au réducteur sont précisées dans le tableau 2.

E El reductor tamaño P50 se suministra, lubricado de por vida con aceite sintético. Para las posiciones V5 y V6 contactar con nuestro servicio técnico. Ver tabla 1, para cantidades y aceites recomendados. En la tabla 2, se encuentran las cargas radiales y axiales admitidas por el reductor.

LUBRICATION P50 Oil
Common lubrication 0.26 l (A + B).



AGIP Telium VSF 320	SHELL Omala S4 WE 320
----------------------------	------------------------------

For all details on lubrication and plugs check our website tab. 1
 Per maggiori dettagli su lubrificazione e tappi olio vedi il nostro sito web

RADIAL AND AXIAL LOADS

Output shaft
Albero di uscita

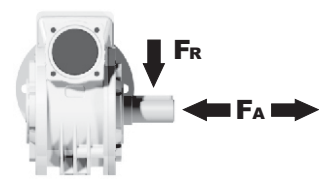

n_2 [min ⁻¹]	FA [N]	FR [N]
75	340	1700
50	380	1900
25	480	2500
15-6	560	2800

Input shaft
albero in entrata

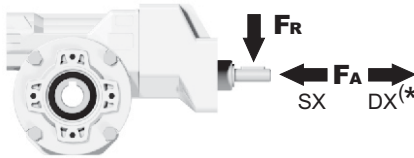

n_1 [min ⁻¹]	FA [N]	FR [N]
1400	44	220

*Strong axial loads in the DX direction are not allowed.
 Non sono consentiti forti carichi assiali con direzione DX

tab. 2

PP50**FB**... Basic wormbox
Riduttore base

Gearbox weight
peso riduttore **3.80 kg**

M. flanges	Kit code	øF	A
56B5	K050.4.046	120	142
63B5	K050.4.041	138	144
71B5	K050.4.042	160	141.5
63B14	K050.4.047	90	144
71B14	K050.4.045	105	141.5

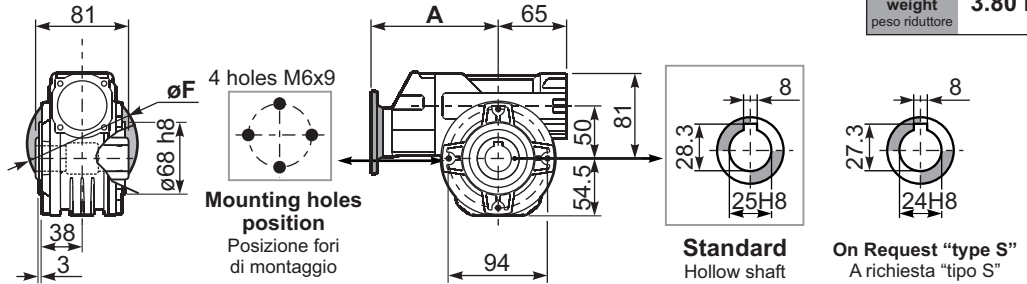

PP50**PA**... Feet
Piedini

PP50**PB**... Feet
Piedini

PP50**PV**... Feet
Piedini

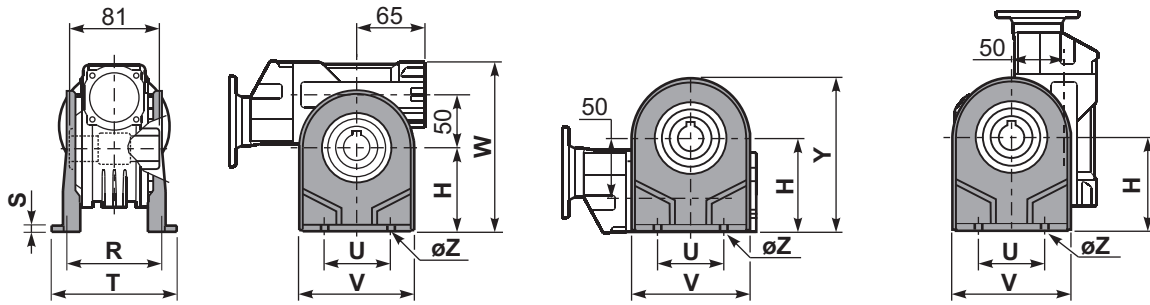

	H	R	S	T	U	V	Y	W	øZ	kit code
type B	82	98.5	3.5	123	63	113	138.5	163	ø10.5	K050.9.022
type S	85	96	10	114	85	110	139.5	166	ø10	KS050.9.023

PP50**FC**... Output flange
Flangia uscita

PP50**BR**... Reaction arm
Braccio di reazione

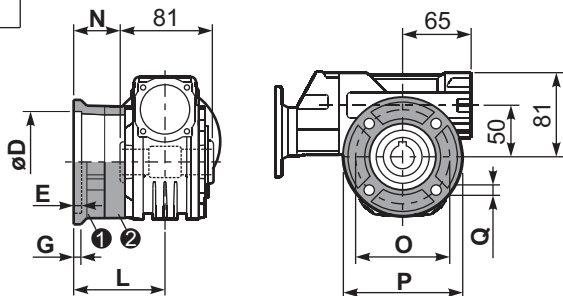

type B	øD	E	G	L	N	O	P	Q	kit code
FC	70 ^{+0.20} / _{+0.15}	9	12	85	44.5	90	123	10.5	1 K050.9.010 2 -
FL	70 ^{+0.20} / _{+0.15}	9	12	114.5	74	90	123	10.5	1 K050.9.010 2 K050.0.200

type S	øD	E	G	L	N	O	P	Q	kit code
F1	110 ^{+0.20} / _{+0.15}	4	11	83.5	43	130	160	10	1 KS050.9.012 2 -
F2	70 ^{+0.20} / _{+0.15}	9	12	76.5	36	90	123	10.5	1 KS050.9.014 2 -
F3	95 ^{+0.035} / ₀	4	10	66.5	26	115	140	10	1 KS050.9.013 2 -

PP50.....**S**... Single Shaft
Albero lento semplice

PP50.....**D**... Double Shaft
Albero lento bisp.

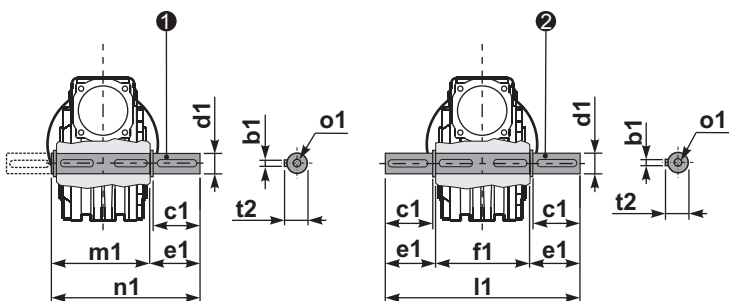

- 1 kit cod. K050.5.028 type B
kit cod. KS050.5.030 type S
- 2 kit cod. K050.5.029 type B
kit cod. KS050.5.031 type S

RP50**FB**... Input shaft
Albero in entrata

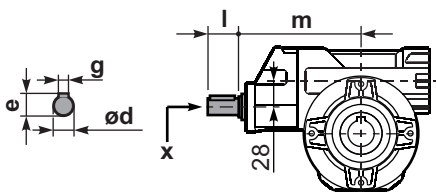

	ød	e	g	l	m	x
type B	14 h6	16	5	25	135.5	M5x13
type S	-	-	-	-	-	-

	b1	c1	d1	e1	f1	l1	m1	n1	t2	o1
type B	8	52	25 ^{-0.005} / _{-0.020}	59.5	81	200	86.5	146	28	M8x20
type S	8	50	24 ^{-0.005} / _{-0.020}	68.8	81	218	86.5	155	27	M8x20

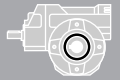

QUICK SELECTION / Selezione veloce

input speed (n_1) = 1400 min⁻¹

	Output Speed n_2 [min ⁻¹]	Ratio i	Motor power P_{1M} [kW]	Output torque M_{2M} [Nm]	Service factor f.s.	Nominal power P_{1R} [kW]	Nominal torque M_{2R} [Nm]	Available B5 motor flanges				Available B14 motor flanges				Dynamic efficiency RD	Tooth Module [mm]	Ratios code
								B	C	D	E	P	Q	R	T			
								63	71	80	90	63	71	80	90			
IEC 90 - 80 - 71	47	29.9	0.75	113	1.5	1.1	165						C	C		74	2.6	01
	37	37.7	0.75	141	1.2	0.88	165						C	C		73	2.0	02
	30	47.1	0.75	169	1.1	0.83	187						C	C		70	3.2	03
	25	56.6	0.55	136	1.4	0.76	187						C	C		64	2.7	04
	19.8	70.7	0.55	164	1.1	0.63	187						C	C		62	2.1	05
	15.9	87.8	0.37	162	1.2	0.43	187						C	C		73	2.6	06
	12.6	111.0	0.37	199	0.9	0.35	187						C	C		71	2.0	07
IEC 71 - 63	10.1	139	0.37	234	0.8	0.30	187						C			67	3.2	08
	8.4	166	0.25	173	1.1	0.27	187						C			61	2.7	09
	6.7	208	0.18	151	1.1	0.20	165						C			59	2.1	10
	4.5	310	0.12	129	1.3	0.15	165						C			51	1.5	11
	3.8	370	0.12	145	1.1	0.14	165						C			48	1.3	12
	3.2	434	0.12	149	0.9	0.11	138						C			42	1.1	13

Motor Flanges Available Flange Motore Disponibili
 B) Supplied with Reduction Bushing Fornito con Bussola di Riduzione
 B) Available on Request without reduction bushing Disponibile a Richiesta senza Bussola di Riduzione
 C) Motor Flange Holes Position Posizione Fori Flangia Motore

EN Unit **P63** is supplied with synthetic oil, providing "long life" lubrication. For mounting position V5-V6 please contact us. See table 1 for lubrication and recommended quantity. In table 2 please see possible radial loads and axial loads on the gearbox.

I Il riduttore tipo **P63** viene fornito lubrificato a vita con olio sintetico. Per posizioni V5-V6 contattare il ns. servizio tecnico. Vedi tab.1 per oli e quantità consigliati. In tab.2 sono presenti i carichi radiali e assiali applicabili al riduttore.

D Für die Lebensdauerschmierung ist das Getriebe der Größe **P63** mit synthetischem Öl befüllt. Bei Einbaulage V5 oder V6 bitten wir um Rücksprache. In Tabelle 1 ist die Schmiermenge und das empfohlene Schmiermittel angegeben. In Tabelle 2 sind die zulässigen Radial- und Axialbelastungen des Getriebes aufgeführt.

F Le réducteur de type **P63** est fourni lubrifié à vie avec de l'huile synthétique. Concernant les positions V5.V6, contactez notre service d'assistance technique. Voir tableau 1 concernant les huiles et les quantités conseillées. Les charges radiales et axiales applicables au réducteur sont précisées dans le tableau 2.

E El reductor tamaño **P63** se suministra, lubricado de por vida con aceite sintético. Para las posiciones V5 y V6 contactar con nuestro servicio técnico. Ver tabla 1, para cantidades y aceites recomendados. En la tabla 2, se encuentran las cargas radiales y axiales admitidas por el reductor.

LUBRICATION P63 Oil

For B3-V5-V6 separate lubrication for A (0.40 l) B (0.08 l) , for B6-B7-B8 common lubrication 0.38 l (A + B).

AGIP Telium VSF 320
 SHELL Omala S4 WE 320

For all details on lubrication and plugs check our website **tab. 1**
 Per maggiori dettagli su lubrificazione e tappi olio vedi il nostro sito web

RADIAL AND AXIAL LOADS

Output shaft
Albero di uscita

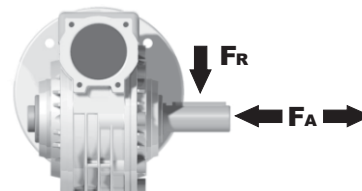

n_2 [min ⁻¹]	FA [N]	FR [N]
75	500	2500
50	600	3000
25	700	3800
15-6	800	4000

Input shaft
albero in entrata

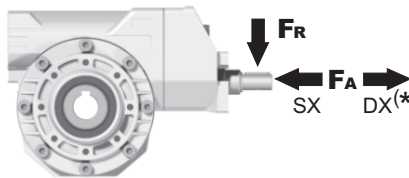

n_1 [min ⁻¹]	FA [N]	FR [N]
1400	61	305

***Strong axial loads in the DX direction are not allowed.**
 Non sono consentiti forti carichi assiali con direzione DX

tab. 2

PP63**FB**... Basic wormbox
Riduttore base

Gearbox weight	29.9+111	139+434
peso riduttore	7.30 Kg	7.80 Kg

M.flange	Kit code	øF	A
71B5	K063.4.042	160	176.5
80/90B5	K063.4.043	200	178.5
71B14	K063.4.047	105	176.5
80B14	K063.4.046	120	178.5
90B14	K063.4.041	140	178.5
<hr/>			
139+434	63B5	K050.4.041	138 162.5
	71B5	K050.4.042	160 160
	63B14	K050.4.047	90 162.5
	71B14	K050.4.045	105 160

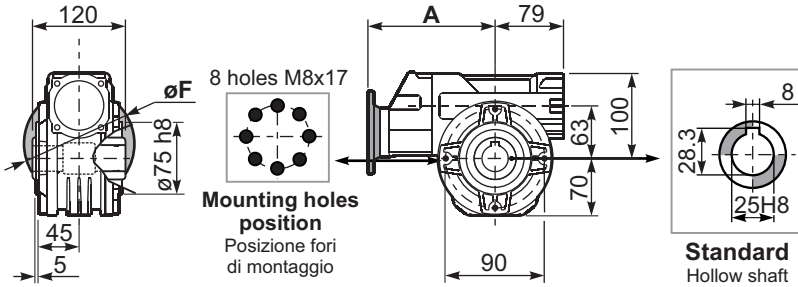

PP63**PA**... Feet
Piedini

PP63**PB**... Feet
Piedini

PP63**PV**... Feet
Piedini

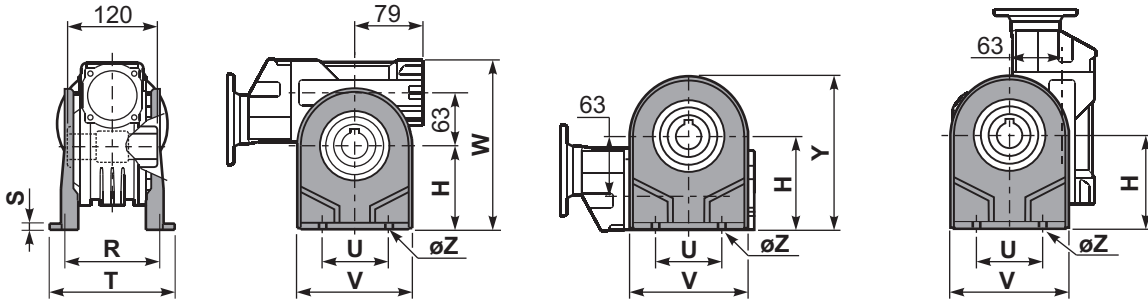

	H	R	S	T	U	V	Y	W	øZ	kit code
type B	100	111	4	144	95	133	170	200	ø10.5	K063.9.022
type S	-	-	-	-	-	-	-	-	-	-

PP63**FC**... Output flange
Flangia uscita

PP63**BR**... Reaction arm
Braccio di reazione

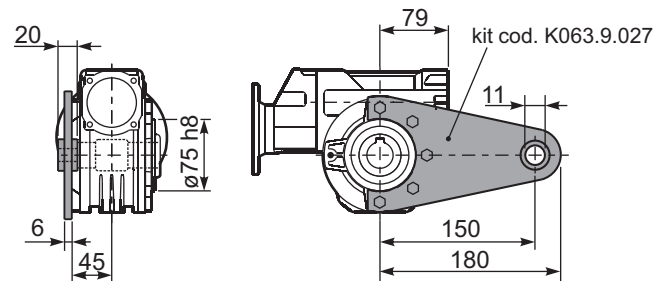
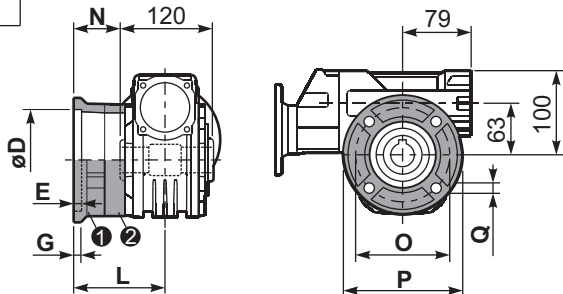

type B	øD	E	G	L	N	O	P	Q	kit code
FC	115 ^{+0.20} / _{+0.15}	7	13	86	26	150	175	11	① K063.9.010 ② -
FL	115 ^{+0.20} / _{+0.15}	7	13	116	56	150	175	11	① K063.9.010 ② K063.0.200
type S	øD	E	G	L	N	O	P	Q	kit code
F1	130 ^{+0.20} / _{+0.15}	7	13	102	42	165	200	13	① KS070.9.013 ② -
F2	115 ^{+0.20} / _{+0.15}	7	13	116	56	150	175	11	① KS063.9.013 ② -
F3	110 ^{+0.035} / ₀	5	11	82	22	130	160	10	① KS063.9.011 ② -

PP63.....**S**... Single Shaft
Albero lento semplice

PP63.....**D**... Double Shaft
Albero lento bisp.

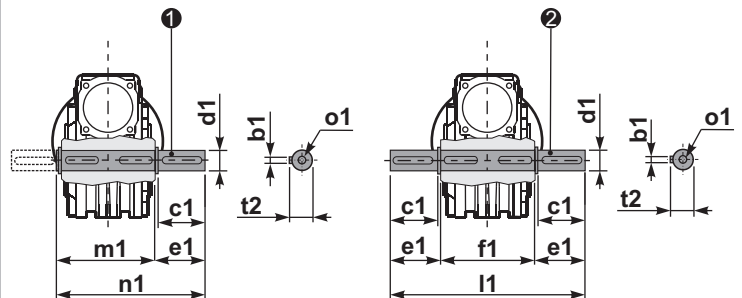

① kit cod. K063.5.028 type B ② kit cod. K063.5.029 type B

RP63**FB**... Input shaft
Albero in entrata

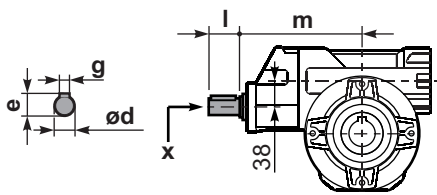

	ød	e	g	l	m	x	
29.9+111	19 h6	21.5	6	35	169.4	M6x16	C40.5.062
139+434	14 h6	16	5	25	154.2	M5x13	C35.5.061

	b1	c1	d1	e1	f1	l1	m1	n1	t2	o1
type B	8	60	25 ^{-0.005} / _{-0.020}	63.2	120	246.4	126.8	190	28	M8x20
type S	-	-	-	-	-	-	-	-	-	-

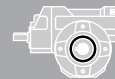

QUICK SELECTION / Selezione veloce

input speed (n₁) = 1400 min⁻¹

	Output Speed n ₂ [min ⁻¹]	Ratio i	Motor power P _{IM} [kW]	Output torque M _{2M} [Nm]	Service factor f.s.	Nominal power P _{1R} [kW]	Nominal torque M _{2R} [Nm]	Available B5 motor flanges				Available B14 motor flanges				Dynamic efficiency RD	Tooth Module [mm]	Ratios code
								B	C	D	E	P	Q	R	T			
								63	71	80	90	63	71	80	90			
IEC 90 - 80 - 71	47	29.9	0.75	113	1.6	1.20	182					C	C		74	2.6	01	
	37	37.7	0.75	141	1.3	0.97	182					C	C		73	2.0	02	
	30	47.1	0.75	169	1.2	0.91	206					C	C		70	3.2	03	
	25	56.6	0.75	185	1.1	0.83	206					C	C		64	2.7	04	
	19.8	70.7	0.55	162	1.3	0.70	206					C	C		61	2.1	05	
	15.9	87.8	0.37	160	1.4	0.51	218					C	C		72	2.6	06	
	12.6	111.0	0.37	196	1.1	0.41	218					C	C		70	2.0	07	
IEC 71 - 63	10.1	139	0.37	231	0.9	0.35	218					C			66	3.2	08	
	8.4	166	0.25	170	1.3	0.32	218					C			60	2.7	09	
	6.7	208	0.25	195	1.0	0.25	194					C			55	2.1	10	
	4.5	310	0.18	194	1.0	0.18	194					C			51	1.5	11	
	3.8	370	0.18	213	0.9	0.16	194					C			47	1.3	12	
	3.2	434	0.18*	143	<0.8	0.11	143					C			42	1.1	13	

Motor Flanges Available
Flange Motore Disponibili

B) Supplied with Reduction Bushing
Fornito con Bussola di Riduzione

B) Available on Request without reduction bushing
Disponibile a Richiesta senza Bussola di Riduzione

C) Motor Flange Holes Position
Posizione Fori Flangia Motore

* Power higher than the maximum one which can be supported by the gearbox. Select according to the torque M_{2R}
Potenza superiore a quella massima sopportabile dal riduttore. Selezionare in base al momento torcente M_{2R}

EN Unit P6A is supplied with synthetic oil, providing "long life" lubrication. For mounting position V5-V6 please contact us. See table 1 for lubrication and recommended quantity. In table 2 please see possible radial loads and axial loads on the gearbox.

I Il riduttore tipo P6A viene fornito lubrificato a vita con olio sintetico. Per posizioni V5-V6 contattare il ns. servizio tecnico. Vedi tab.1 per oli e quantità consigliati. In tab.2 sono presenti i carichi radiali e assiali applicabili al riduttore.

D Für die Lebensdauerschmierung ist das Getriebe der Größe P6A mit synthetischem Öl befüllt. Bei Einbaulage V5 oder V6 bitten wir um Rücksprache. In Tabelle 1 ist die Schmiermenge und das empfohlene Schmiermittel angegeben. In Tabelle 2 sind die zulässigen Radial- und Axialbelastungen des Getriebes aufgeführt.

F Le réducteur de type P6A est fourni lubrifié à vie avec de l'huile synthétique. Concernant les positions V5.V6, contactez notre service d'assistance technique. Voir tableau 1 concernant les huiles et les quantités conseillées. Les charges radiales et axiales applicables au réducteur sont précisées dans le tableau 2.

E El reductor tamaño P6A se suministra, lubricado de por vida con aceite sintético. Para las posiciones V5 y V6 contactar con nuestro servicio técnico. Ver tabla 1, para cantidades y aceites recomendados. En la tabla 2, se encuentran las cargas radiales y axiales admitidas por el reductor.

LUBRICATION P6A Oil

For B3-V5-V6 separate lubrication for A (0.40 l) B (0.08 l) , for B6-B7-B8 common lubrication 0.38 l (A + B).

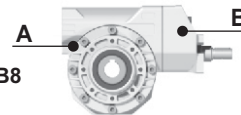

AGIP Telium VSF 320

SHELL Omala S4 WE 320

For all details on lubrication and plugs check our website **tab. 1**
Per maggiori dettagli su lubrificazione e tappi olio vedi il nostro sito web

RADIAL AND AXIAL LOADS

Output shaft

Albero di uscita

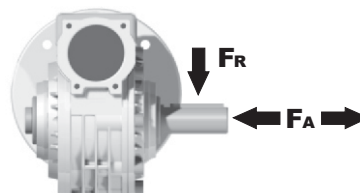

n ₂ [min ⁻¹]	FA [N]	FR [N]
75	500	2500
50	600	3000
25	700	3800
15-6	800	4000

Input shaft

albero in entrata

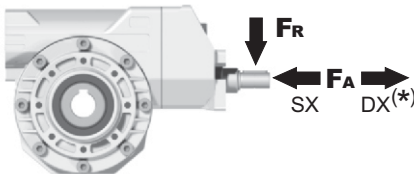

n ₁ [min ⁻¹]	FA [N]	FR [N]
1400	61	305

*Strong axial loads in the DX direction are not allowed.
Non sono consentiti forti carichi assiali con direzione DX

tab. 2

PP6AFB... Basic wormbox
Riduttore base

Gearbox weight peso riduttore	29.9+111	139+434
	7.30 Kg	7.80 Kg

M.flange	Kit code	øF	A
71B5	K063.4.042	160	176.5
80/90B5	K063.4.043	200	178.5
71B14	K063.4.047	105	176.5
80B14	K063.4.046	120	178.5
90B14	K063.4.041	140	178.5
<hr/>			
139+434			
63B5	K050.4.041	138	162.5
71B5	K050.4.042	160	160
63B14	K050.4.047	90	162.5
71B14	K050.4.045	105	160

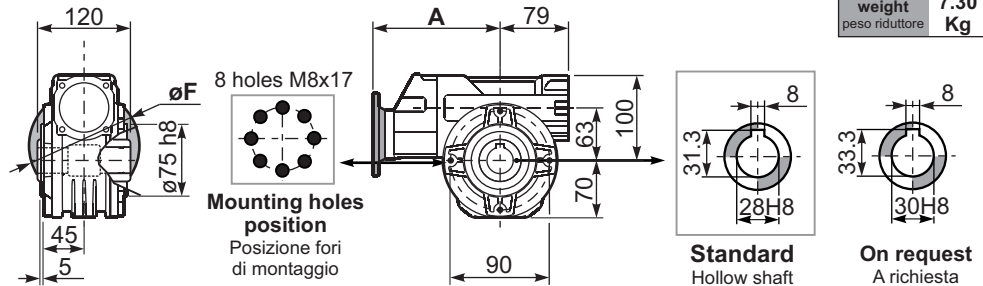

PP6APA... Feet
Piedini

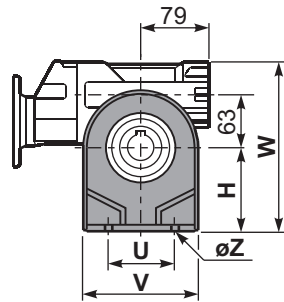
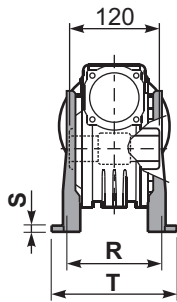

PP6APB... Feet
Piedini

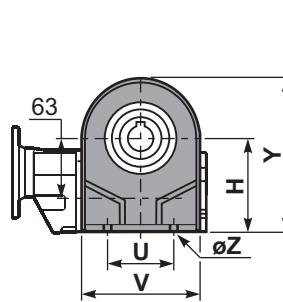

PP6APV... Feet
Piedini

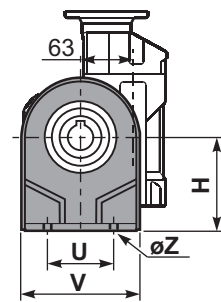

	H	R	S	T	U	V	Y	W	øZ	kit code
type B	115	115	12	142	120	156	185	215	ø11	K070.9.022
type S	-	-	-	-	-	-	-	-	-	-

PP6AFC... Output flange
Flangia uscita

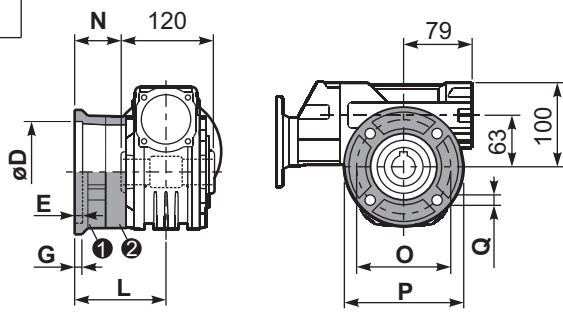

type B	øD	E	G	L	N	O	P	Q	kit code
FC	130 ^{+0.20} / _{+0.15}	7	13	85	25	165	200	13	① K070.9.010 ② -
FL	130 ^{+0.20} / _{+0.15}	7	13	111	51	165	200	13	① K070.9.010 ② K070.0.200
type S	øD	E	G	L	N	O	P	Q	kit code
F1	130 ^{+0.20} / _{+0.15}	7	13	111	51	165	200	13	① KS070.9.014 ② -
F2	115 ^{+0.20} / _{+0.15}	7	13	116	56	150	175	11	① KS063.9.013 ② -
F3	110 ^{+0.035} / ₀	5	13.5	84.5	24.5	130	160	11	① KS070.9.011 ② -

PP6ABR... Reaction arm
Braccio di reazione

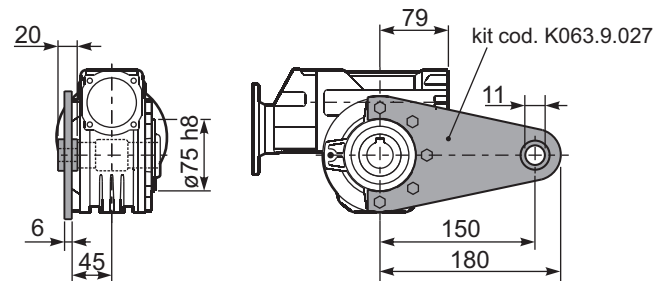

PP6A....S... Single Shaft
Albero lento semplice

PP6A....D... Double Shaft
Albero lento bisp.

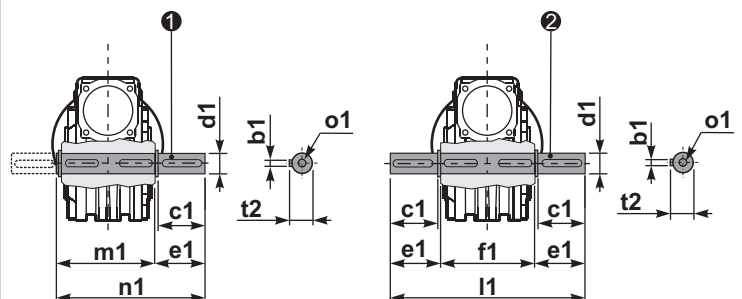

① kit cod. K070.5.028 type B

② kit cod. K070.5.029 type B

RP6AFB... Input shaft
Albero in entrata

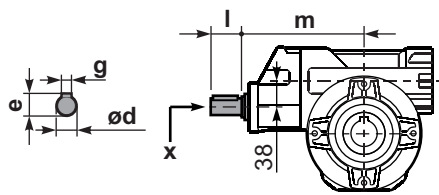

	ød	e	g	l	m	x	
29.9+111	19 h6	21.5	6	35	169.4	M6x16	C40.5.062
139+434	14 h6	16	5	25	154.2	M5x13	C35.5.061

	b1	c1	d1	e1	f1	l1	m1	n1	t2	o1
type B	8	60	28 ^{-0.005} / _{-0.020}	63.5	120	247	127.5	191	31	M8x20
type S	-	-	-	-	-	-	-	-	-	-

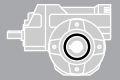

QUICK SELECTION / Selezione veloce

input speed (n_1) = 1400 min⁻¹

Output Speed n_2 [min ⁻¹]	Ratio i	Motor power P_{1M} [kW]	Output torque M_{2M} [Nm]	Service factor f.s.	Nominal power P_{1R} [kW]	Nominal torque M_{2R} [Nm]	Available B5 motor flanges				Available B14 motor flanges			Dynamic efficiency RD	Tooth Module [mm]	Ratios code
							B	C	D	E	Q	R	T			
							63	71	80	90	71	80	90			
23.5	59.7	1.1	300	1.4	1.5	418					C	C		67	3.5	01
19.4	72.3	1.1	347	1.2	1.3	407					C	C		64	3.1	02
17.1	81.7	1.1	374	1.1	1.2	418					C	C		61	2.7	03
13.3	105	0.75	323	1.2	0.89	385					C	C		60	2.1	04
8.0	176	0.55	415	1.1	0.58	440	B				C	C		63	3.5	05
6.6	213	0.37	322	1.3	0.47	407	B				C	C		60	3.1	06
5.8	240	0.37	321	1.3	0.48	418	B				C	C		53	2.7	07
4.3	328	0.37	438	1.0	0.35	418	B				C	C		53	2.7	08
3.3	422	0.25	374	1.0	0.26	385	B				C	C		52	2.1	09
3.0	466	0.25	358	0.9	0.23	330	B				C	C		45	1.9	10
2.3	605	0.18	297	1.1	0.20	330	B				C	C		40	1.5	11

Motor Flanges Available
Flange Motore Disponibili

B) Supplied with Reduction Bushing
Fornito con Bussola di Riduzione

B) Available on Request without reduction bushing
Disponibile a Richiesta senza Bussola di Riduzione

C) Motor Flange Holes Position
Posizione Fori Flangia Motore

EN Unit **P85** is supplied with synthetic oil, providing "long life" lubrication. For mounting position V5-V6 please contact us. See table 1 for lubrication and recommended quantity. In table 2 please see possible radial loads and axial loads on the gearbox.

I Il riduttore tipo **P85** viene fornito lubrificato a vita con olio sintetico. Per posizioni V5-V6 contattare il ns. servizio tecnico. Vedi tab.1 per oli e quantità consigliati. In tab.2 sono presenti i carichi radiali e assiali applicabili al riduttore.

D Für die Lebensdauerschmierung ist das Getriebe der Größe **P85** mit synthetischem Öl befüllt. Bei Einbaulage V5 oder V6 bitten wir um Rücksprache. In Tabelle 1 ist die Schmiermenge und das empfohlene Schmiermittel angegeben. In Tabelle 2 sind die zulässigen Radial- und Axialbelastungen des Getriebes aufgeführt.

F Le réducteur de type **P85** est fourni lubrifié à vie avec de l'huile synthétique. Concernant les positions V5.V6, contactez notre service d'assistance technique. Voir tableau 1 concernant les huiles et les quantités conseillées. Les charges radiales et axiales applicables au réducteur sont précisées dans le tableau 2.

E El reductor tamaño **P85** se suministra, lubricado de por vida con aceite sintético. Para las posiciones V5 y V6 contactar con nuestro servicio técnico. Ver tabla 1, para cantidades y aceites recomendados. En la tabla 2, se encuentran las cargas radiales y axiales admitidas por el reductor.

LUBRICATION P85 Oil

For B3-V5-V6 separate lubrication for A (1.20 l) B (0.14 l) , for B6-B7-B8 common lubrication 0.90 l (A + B).



AGIP Telium VSF 320

SHELL Omala S4 WE 320

For all details on lubrication and plugs check our website **tab. 1**
Per maggiori dettagli su lubrificazione e tappi olio vedi il nostro sito web

RADIAL AND AXIAL LOADS

Output shaft

Albero di uscita

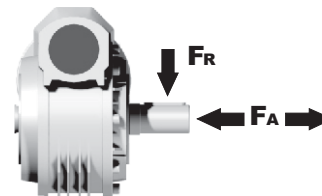

n_2 [min ⁻¹]	F_A [N]	F_R [N]
75	700	3500
50	800	4000
25	1000	5000
15-6	1160	5800

Input shaft

albero in entrata

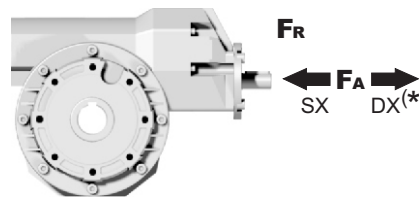

n_1 [min ⁻¹]	F_A [N]	F_R [N]
1400	108	540

***Strong axial loads in the DX direction are not allowed.**
Non sono consentiti forti carichi assiali con direzione DX

tab. 2

PP85**FB**... Basic wormbox
Riduttore base

Gearbox weight
peso riduttore **19.30 kg**

M. flanges	Kit code	øF	A
63B5	K063.4.041	140	195.2
71B5	K063.4.042	160	193.2
80/90B5	K063.4.043	200	195.2
71B14	K063.4.047	105	193.2
80B14	K063.4.046	120	195.2
90B14	K063.4.041	140	195.2

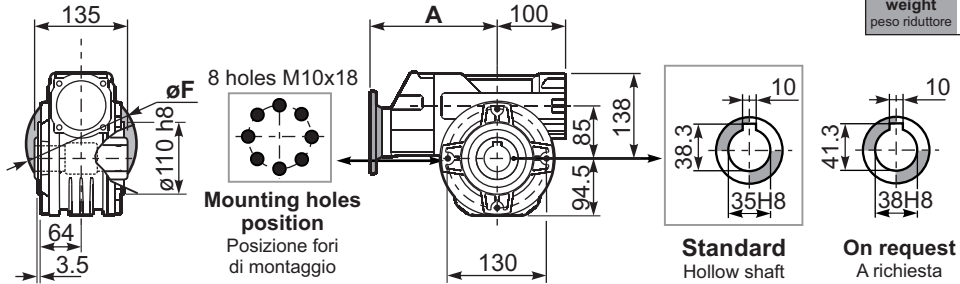

PP85**PA**... Feet
Piedini

PP85**PB**... Feet
Piedini

PP85**PV**... Feet
Piedini

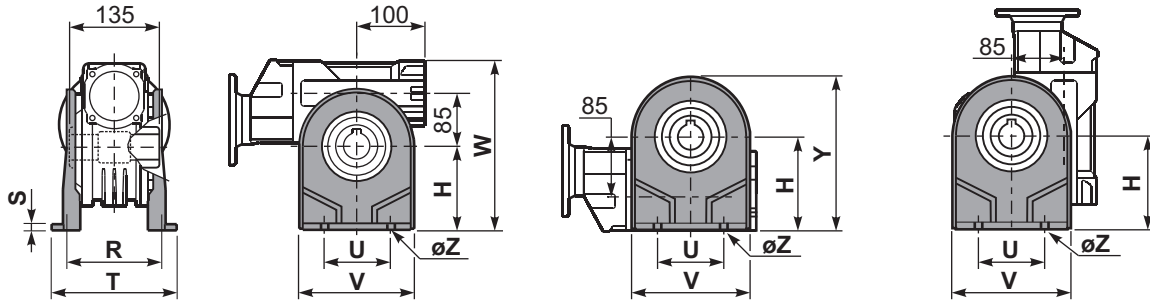

	H	R	S	T	U	V	Y	W	øZ	kit code
type B	142	145	5	182	140	180	236.5	280	ø10.5	K085.9.022
type S	-	-	-	-	-	-	-	-	-	-

PP85**FC**... Output flange
Flangia uscita

PP85**BR**... Reaction arm
Braccio di reazione

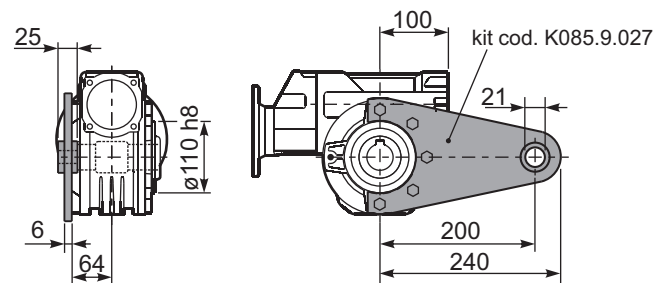
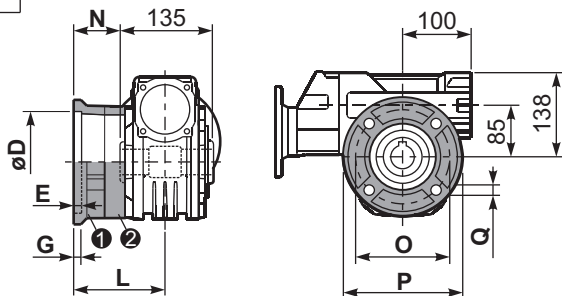

type B	øD	E	G	L	N	O	P	Q	kit code
FC	152 ^{+0.06} / _{+0.00}	5	16	108	40.5	176	205	13	① K085.9.010 ② -
FL	152 ^{+0.06} / _{+0.00}	5	16	148.5	81	176	205	13	① K085.9.010 ② K085.0.201

type S	øD	E	G	L	N	O	P	Q	kit code
F1	130 ^{+0.04} / _{+0.00}	5	13	117.5	50	165	200	11.5	① KS085.9.012 ② -
F2	152 ^{+0.06} / _{+0.00}	5	15	147.5	80	180	205	12.5	① KS085.9.013 ② -
F4	130 ^{+0.04} / _{+0.00}	5	13	106.5	39	165	200	13	① KS085.9.015 ② -

PP85.....**S**... Single Shaft
Albero lento semplice

PP85.....**D**... Double Shaft
Albero lento bisp.

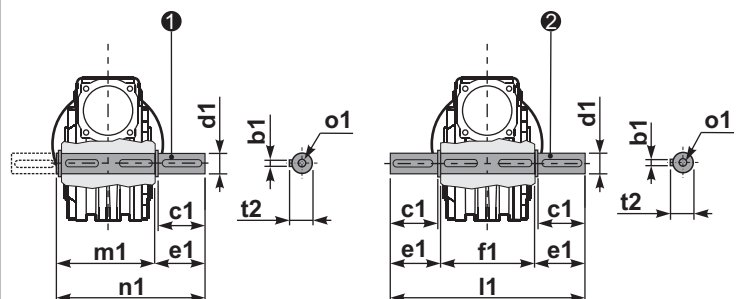

① kit cod. K085.5.028 type B

② kit cod. K085.5.029 type B

RP85FB... Input shaft
Albero in entrata

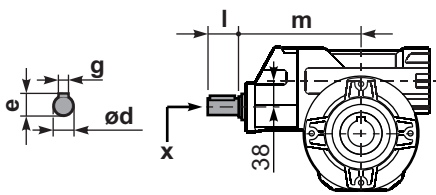

	ød	e	g	l	m	x
type B	19 h6	21.5	6	35	187.5	M6x16
type S	-	-	-	-	-	-

	b1	c1	d1	e1	f1	l1	m1	n1	t2	o1
type B	10	60	35 ^{-0.005} / _{-0.020}	73.5	135	282	141	214.5	38	M10x23
type S	-	-	-	-	-	-	-	-	-	-

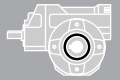

QUICK SELECTION / Selezione veloce

input speed (n_1) = 1400 min⁻¹

Output Speed n_2 [min ⁻¹]	Ratio i	Motor power P_{1M} [kW]	Output torque M_{2M} [Nm]	Service factor f.s.	Nominal power P_{1R} [kW]	Nominal torque M_{2R} [Nm]	Available B5 motor flanges				Available B14 motor flanges			Dynamic efficiency RD	Tooth Module [mm]	Ratios code
							B	C	D	E	Q	R	T			
							63	71	80	90	71	80	90			
16.8	83.2	1.5	587	1.1	1.7	660					C			69	3.5	01
13.9	100.5	1.5	699	0.8	1.3	594					C			68	2.9	02
10.6	132	1.1	634	0.9	0.95	550					C			64	2.2	03
8.0	176	0.75	666	1.2	0.90	803	B				C			74	4.7	04
6.7	208	0.75	766	0.9	0.65	660	B				C			72	4.0	05
5.7	245	0.55	634	1.0	0.57	660	B				C			69	3.5	06
4.7	296	0.55	755	0.8	0.43	594	B				C			68	2.9	07
4.2	334	0.55	865	0.8	0.42	660	B				C			69	3.5	08
3.5	403	0.37	692	0.9	0.32	594	B				C			68	2.9	09
2.6	529	0.25	577	1.0	0.24	550	B				C			64	2.2	10
2.2	624	0.25	628	0.8	0.21	528	B				C			59	1.9	11

Motor Flanges Available
Flange Motore Disponibili

B) Supplied with Reduction Bushing
Fornito con Bussola di Riduzione

B) Available on Request without reduction bushing
Disponibile a Richiesta senza Bussola di Riduzione

C) Motor Flange Holes Position
Posizione Fori Flangia Motore

EN Unit **P10** is supplied without lubricant and equipped with a breather, level and drain plugs. User can add mineral oil keeping existing plugs. Should the user wish to fill it with synthetic oil, it is recommended to replace the existing plugs with a closed plug. Primary reduction unit is supplied with closed plugs and lubricated for life with synthetic oil. See table 1 for lubrication and recommended quantity. In table 2 please see possible radial loads and axial loads on the gearbox.

I Il riduttore tipo **P10** è fornito privo di lubrificazione con tappi di sfiato, livello e scarico olio. L'utente può immettere olio minerale mantenendo i tappi esistenti. Se immetterà olio sintetico, dovrà sostituire i tappi esistenti con altri tipo chiuso. La precoppia è fornita con tappi chiusi e lubrificata a vita con olio sintetico. Tab.1 per oli e quantità consigliati. Tab.2 carichi radiali e assiali applicabili al riduttore.

D Das Getriebe der Baugröße **P10** wird ohne Schmiermittel geliefert. Es ist jedoch mit Einfüllschraube, Überdruckventil und Ablassschraube ausgerüstet. Das benötigte mineralische Öl kann über die Einfüllschraube eingefüllt werden. Sollte synthetisches Öl bevorzugt werden, so ist sind das eingebaute Überdruckventil durch eine geschlossenen Schraube zu ersetzen. Die Stirnradvorstufe ist Lebensdauer geschmiert und wird mit synthetischem Öl geliefert. Die Stirnradvorstufe ist komplett geschlossen ohne Füllschrauben. In Tabelle 1 ist die Schmiermenge und das empfohlene Schmiermittel angegeben. In Tabelle 2 sind die zulässigen Radial- und Axialbelastungen des Getriebes aufgeführt.

F Le réducteur de type **P10** est fourni sans lubrification et avec un bouchon de remplissage, de niveau et d'évacuation de l'huile. L'utilisateur peut y verser de l'huile minérale en conservant les bouchons existants. S'il y versera de l'huile synthétique, il devra substituer les bouchons existants avec d'autres bouchons de type fermé. Le pré couple est fourni lubrifié à vie avec de l'huile synthétique et avec des bouchons fermés. Voir tableau 1 concernant les huiles et les quantités conseillées. Voir tableau 2 concernant les charges radiales et axiales applicables au réducteur

E El reductor tamaño **P10** se suministra sin lubricante, provisto de tapones de respiración, nivel y descarga de aceite. El usuario puede utilizar aceite mineral, manteniendo los tapones existentes. Si prefiere utilizar aceite sintético deberá sustituir los tapones existentes por tapones ciegos. La prerreducción se suministra con tapones ciegos, lubricado de por vida con aceite sintético. Ver tabla 1, para cantidades y aceites recomendados. En la tabla 2, se encuentran las cargas radiales y axiales admitidas por el reductor.

B3	B6	B7	B8	V5	V6
2.0/0.14LT	1.5/0.14 LT	1.5/0.14 LT	2.0/0.14 LT	2.0/0.14 LT	2.0/0.14 LT
AGIP Blasia 460					

For all details on lubrication and plugs check our website [tab. 1](#)
Per maggiori dettagli su lubrificazione e tappi olio vedi il nostro sito web

RADIAL AND AXIAL LOADS

Output shaft
Albero di uscita

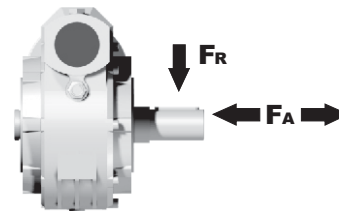

n_2 [min ⁻¹]	FA [N]	FR [N]
75	800	4000
50	920	4600
25	1200	6000
15-6	1400	7000

Input shaft
albero in entrata

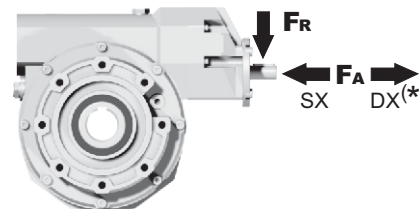

n_1 [min ⁻¹]	FA [N]	FR [N]
1400	150	760

***Strong axial loads in the DX direction are not allowed.**
Non sono consentiti forti carichi assiali con direzione DX

tab. 2

PP10**FB**... Basic wormbox
Riduttore base

Gearbox weight
peso riduttore **41.00 kg**

M. flanges	Kit code	øF	A
63B5	K063.4.041	140	214.7
71B5	K063.4.042	160	212.7
80/90B5	K063.4.043	200	214.7
71B14	K063.4.047	105	212.7
80B14	K063.4.046	120	214.7
90B14	K063.4.041	140	214.7

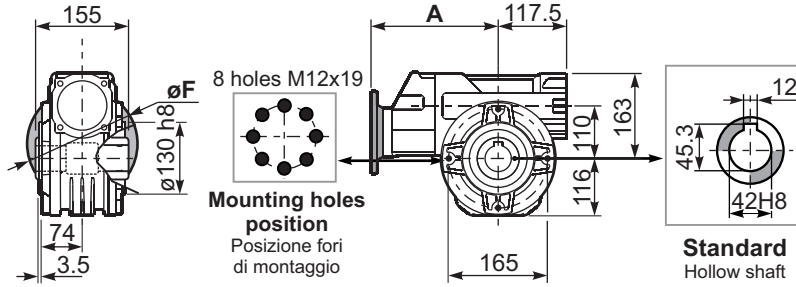

PP10**PA**... Feet
Piedini

PP10**PB**... Feet
Piedini

PP10**PV**... Feet
Piedini

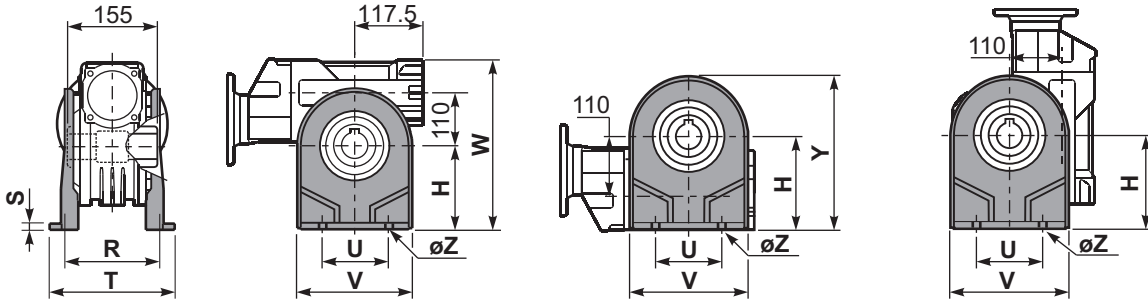

	H	R	S	T	U	V	Y	W	øZ	kit code
type B	170	180	22	224	200	240	286	333	ø13	K110.9.022
type S	172	160	18	190	200	240	288	335	ø14	KS110.9.023

PP10**FC**... Output flange
Flangia uscita

PP10**BR**... Reaction arm
Braccio di reazione

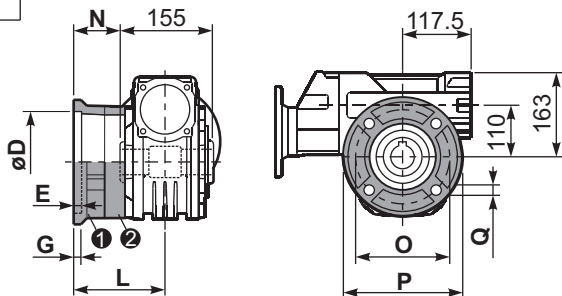

type B	øD	E	G	L	N	O	P	Q	kit code
FC	170 ^{+0.083} ₀ ^{+0.043}	11	16.5	131.5	54	230	270	13	1 K110.9.010 2 -
FL	170 ^{+0.083} ₀ ^{+0.043}	11	16.5	179.5	102	230	270	13	1 K110.9.011 2 -

type S	øD	E	G	L	N	O	P	Q	kit code
F1	180 ^{+0.040} ₀	5	18	150	72.5	215	250	15	1 KS110.9.014 2 -
F2	170 ^{+0.083} ₀ ^{+0.043}	9.5	15	178	100.5	230	270	13	1 KS110.9.012 2 -
F3	180 ^{+0.040} ₀	5	18	130	52.5	215	250	15	1 KS110.9.013 2 -

PP10.....**S**... Single Shaft
Albero lento semplice

PP10.....**D**... Double Shaft
Albero lento bisp.

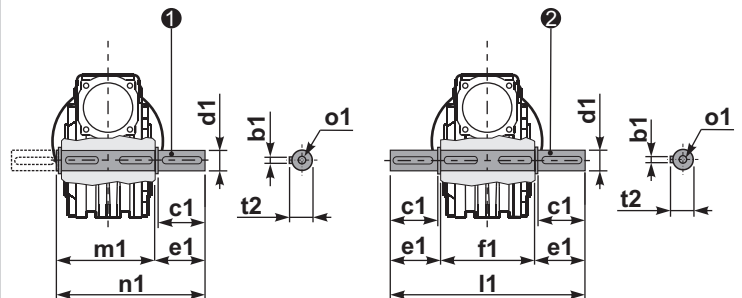

1 kit cod. K110.5.028 type B

2 kit cod. K110.5.029 type B

RP10**FB**... Input shaft
Albero in entrata

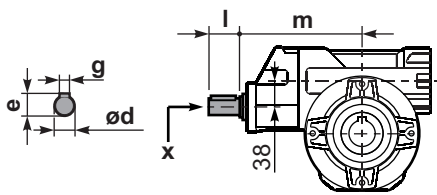

	ød	e	g	l	m	x
type B	19 h6	21.5	6	35	205	M6x16
type S	-	-	-	-	-	-

	b1	c1	d1	e1	f1	l1	m1	n1	t2	o1
type B	12	75	42 ^{-0.005} ₀ ^{-0.020}	96.5	155	348	163.5	260	45	M12x32
type S	-	-	-	-	-	-	-	-	-	-

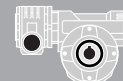

QUICK SELECTION / Selezione veloce

input speed (n_1) = 1400 min⁻¹

Output Speed n_2 [min ⁻¹]	Ratio i	Motor power P_{1M} [kW]	Output torque M_{2M} [Nm]	Service factor f.s.	Nominal power P_{1R} [kW]	Nominal torque M_{2R} [Nm]	Available B5 motor flanges		Available B14 motor flanges		Dynamic efficiency RD	Tooth Module [mm]	 Ratios code
							A	B	O	P			
							56	63	56	63			
9.3	150	0.06	29	1.2	0.07	35	B		B-C		48	1.44	01
6.7	210	0.06	39	0.9	0.05	35	B		B-C		45	1.44	02
4.7	300	0.06*	35	<0.8	0.05	35	B		B-C		36	1.44	03
3.1	450	0.06*	35	<0.8	0.03	35	B		B-C		33	1.44	04
2.3	600	0.06*	35	<0.8	0.03	35	B		B-C		30	1.44	05
1.6	900	0.06*	35	<0.8	0.02	35	B		B-C		27	1.44	06
1.2	1200	0.06*	35	<0.8	0.02	35	B		B-C		26	1.44	07
0.8	1830	0.06*	35	<0.8	0.01	35	B		B-C		24	1.44	08
0.6	2400	0.06*	35	<0.8	0.01	35	B		B-C		22	1.44	09

A) Motor Flanges Available
Flange Motore Disponibili

B) Supplied with Reduction Bushing
Fornito con Bussola di Riduzione

B) Available on Request without reduction bushing
Disponibile a Richiesta senza Bussola di Riduzione

C) Motor Flange Holes Position
Posizione Fori Flangia Motore

* Power higher than the maximum one which can be supported by the gearbox. Select according to the torque M_{2R}
Potenza superiore a quella massima sopportabile dal riduttore. Selezionare in base al momento torcente M_{2R}

EN Unit 303 is supplied with synthetic oil, providing "long life" lubrication. For mounting position V5-V6 please contact us. See table 1 for lubrication and recommended quantity. In table 2 please see possible radial loads and axial loads on the gearbox.

I Il riduttore tipo 303 viene fornito lubrificato a vita con olio sintetico. Per posizioni V5-V6 contattare il ns. servizio tecnico. Vedi tab.1 per oli e quantità consigliati. In tab.2 sono presenti i carichi radiali e assiali applicabili al riduttore.

D Für die Lebensdauerschmierung ist das Getriebe der Größe 303 mit synthetischem Öl befüllt. Bei Einbaulage V5 oder V6 bitten wir um Rücksprache. In Tabelle 1 ist die Schmiermenge und das empfohlene Schmiermittel angegeben. In Tabelle 2 sind die zulässigen Radial- und Axialbelastungen des Getriebes aufgeführt.

F Le réducteur de type 303 est fourni lubrifié à vie avec de l'huile synthétique. Concernant les positions V5.V6, contactez notre service d'assistance technique. Voir tableau 1 concernant les huiles et les quantités conseillées. Les charges radiales et axiales applicables au réducteur sont précisées dans le tableau 2.

E El reductor tamaño 303 se suministra, lubricado de por vida con aceite sintético. Para las posiciones V5 y V6 contactar con nuestro servicio técnico. Ver tabla 1, para cantidades y aceites recomendados. En la tabla 2, se encuentran las cargas radiales y axiales admitidas por el reductor.

LUBRICATION 303 Oil 0.03 Lt. 0.03 Lt.

Quantity 0.03/0.03 Lt.

AGIP Telium VSF 320

SHELL Omala S4 WE 320

For all details on lubrication and plugs check our website **tab. 1**
Per maggiori dettagli su lubrificazione e tappi olio vedi il nostro sito web

RADIAL AND AXIAL LOADS

Output shaft

Albero di uscita

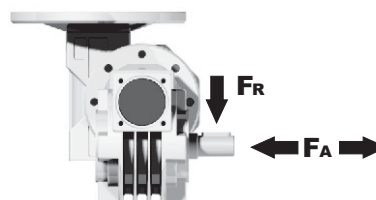

n_2 [min ⁻¹]	FA [N]	FR [N]
25	300	1800
15	400	2000

Input shaft

albero in entrata

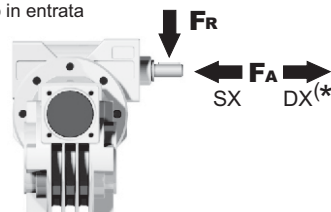

n_1 [min ⁻¹]	FA [N]	FR [N]
1400	20	100

*Strong axial loads in the DX direction are not allowed.
Non sono consentiti forti carichi assiali con direzione DX

tab. 2

3D dimensions on request

P303FB... Basic wormbox
Riduttore base

Gearbox weight
peso riduttore **2.15 kg**

M. flanges	Kit code	øF	A
56B5	K030.4.041	120	61.5
63B5	K030.4.042	140	62.5
56B14	K030.4.046	80	61.5
63B14	K030.4.045	90	62.5

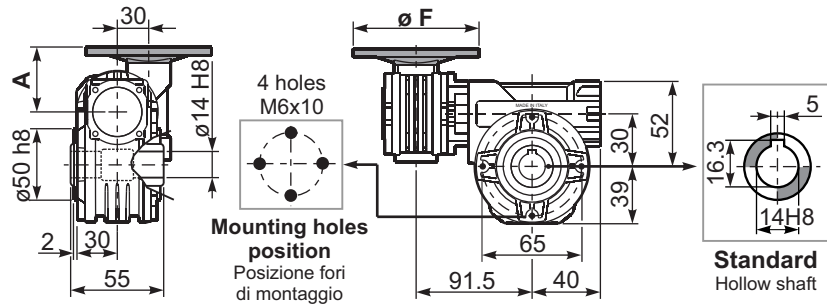

P303PA... Feet
Piedini

P303PB... Feet
Piedini

P303PV... Feet
Piedini

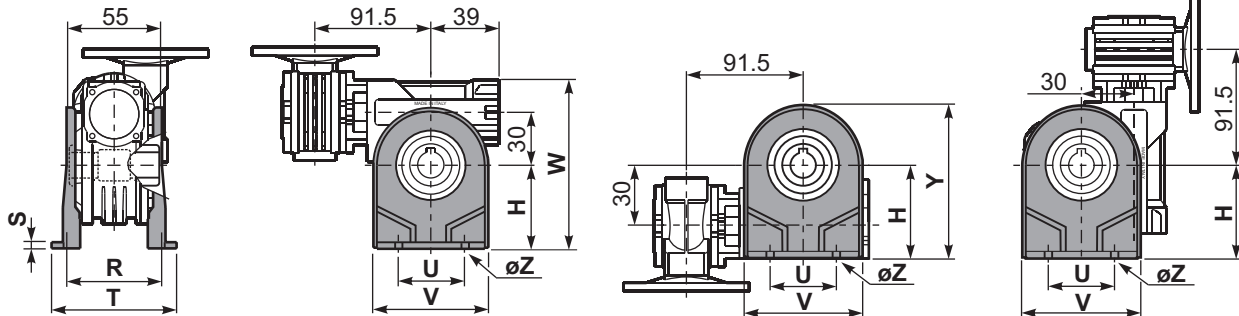

	H	R	S	T	U	V	Y	W	øZ	kit code
type B	55	66	3	87	50	78	94	107	ø6.5	K030.9.022
type S	52	66	3	87	52	90	91	104	ø6.5	KS030.9.023

P303FC... Output flange
Flangia uscita

P303BR... Reaction arm
Braccio di reazione

kit cod. K045.9.027

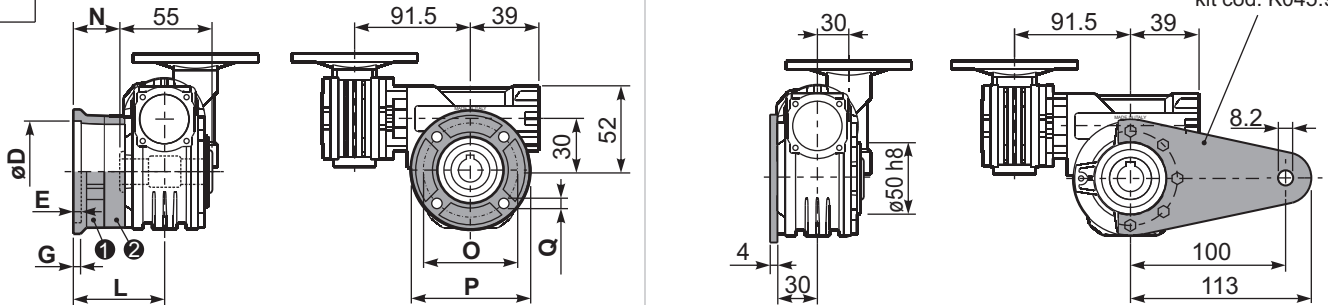

type B	øD	E	G	L	N	O	P	Q	kit code
FC	50 ^{+0.15} / _{+0.05}	6	6	50.5	23	68	80	7	1 K030.9.010 2 -
FL	60 ^{+0.15} / _{+0.05}	6	6	55.5	28	87	110	8.5	1 K030.9.011 2 -
type S	øD	E	G	L	N	O	P	Q	kit code
F1	40 ^{+0.15} / _{+0.10}	3.5	5.5	49	21.5	56	80	6.5	1 KS030.9.012 2 -

P303....S... Single Shaft
Albero lento semplice

P303....D... Double Shaft
Albero lento bisp.

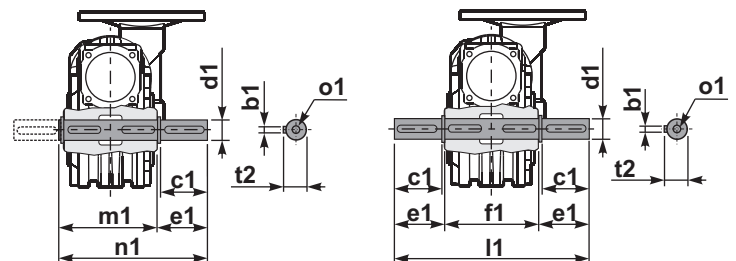

1 kit cod. K030.5.028 type B

2 kit cod. K030.5.029 type B

R303FB... Input shaft
Albero in entrata

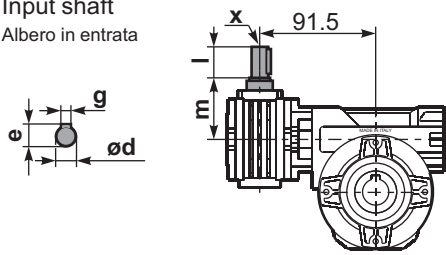

	ød	e	g	l	m	x	kit code
type B	9 h6	10.2	3	20	58	-	K030.5.006 PAM63
type S	-	-	-	-	-	-	-

	b1	c1	d1	e1	f1	l1	m1	n1	t2	o1
type B	5	25	14 ^{-0.005} / _{-0.020}	35.5	55	126	59	94.5	15.8	M5x14
type S	-	-	-	-	-	-	-	-	-	-

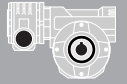

QUICK SELECTION / Selezione veloce

input speed (n_1) = 1400 min⁻¹

Output Speed n_2 [min ⁻¹]	Ratio i	Motor power P_{1M} [kW]	Output torque M_{2M} [Nm]	Service factor f.s.	Nominal power P_{1R} [kW]	Nominal torque M_{2R} [Nm]	Available B5 motor flanges		Available B14 motor flanges		Dynamic efficiency RD	Tooth Module [mm]	Ratios code
							A	B	O	P			
							56	63	56	63			
10.0	140	0.12	57	1.2	0.14	69	B		B-C		50	2.2	01
7.0	200	0.12	79	0.9	0.11	69	B		B-C		48	2.2	02
5.0	280	0.12*	69	<0.8	0.08	69	B		B-C		45	2.4	03
3.3	420	0.12*	69	<0.8	0.07	69	B		B-C		36	1.6	04
2.5	560	0.12*	69	<0.8	0.05	69	B		B-C		33	2.5	05
1.9	740	0.12*	69	<0.8	0.05	69	B		B-C		30	1.8	06
1.5	920	0.12*	69	<0.8	0.04	69	B		B-C		27	1.5	07
1.3	1120	0.12*	69	<0.8	0.03	69	B		B-C		26	2.5	08
0.9	1480	0.12*	69	<0.8	0.03	69	B		B-C		24	1.8	09
0.8	1840	0.12*	69	<0.8	0.02	69	B		B-C		22	1.5	10
0.6	2400	0.12*	69	<0.8	0.02	69	B		B-C		21	1.2	11

Motor Flanges Available Flange Motore Disponibili
B) Supplied with Reduction Bushing Fornito con Bussola di Riduzione
B) Available on Request without reduction bushing Disponibile a Richiesta senza Bussola di Riduzione
C) Motor Flange Holes Position Posizione Fori Flangia Motore

* Power higher than the maximum one which can be supported by the gearbox. Select according to the torque M_{2R}
 Potenza superiore a quella massima sopportabile dal riduttore. Selezionare in base al momento torcente M_{2R}

EN Unit 453 is supplied with synthetic oil, providing "long life" lubrication. For mounting position V5-V6 please contact us. See table 1 for lubrication and recommended quantity. In table 2 please see possible radial loads and axial loads on the gearbox.

I Il riduttore tipo 453 viene fornito lubrificato a vita con olio sintetico. Per posizioni V5-V6 contattare il ns. servizio tecnico. Vedi tab.1 per oli e quantità consigliati. In tab.2 sono presenti i carichi radiali e assiali applicabili al riduttore.

D Für die Lebensdauerschmierung ist das Getriebe der Größe 453 mit synthetischem Öl befüllt. Bei Einbaulage V5 oder V6 bitten wir um Rücksprache. In Tabelle 1 ist die Schmiermenge und das empfohlene Schmiermittel angegeben. In Tabelle 2 sind die zulässigen Radial- und Axialbelastungen des Getriebes aufgeführt.

F Le réducteur de type 453 est fourni lubrifié à vie avec de l'huile synthétique. Concernant les positions V5.V6, contactez notre service d'assistance technique. Voir tableau 1 concernant les huiles et les quantités conseillées. Les charges radiales et axiales applicables au réducteur sont précisées dans le tableau 2.

E El reductor tamaño 453 se suministra, lubricado de por vida con aceite sintético. Para las posiciones V5 y V6 contactar con nuestro servicio técnico. Ver tabla 1, para cantidades y aceites recomendados. En la tabla 2, se encuentran las cargas radiales y axiales admitidas por el reductor.

LUBRICATION 453 Oil 0.09 Lt. 0.03 Lt.

AGIP Telium VSF 320	SHELL Omala S4 WE 320
----------------------------	------------------------------

For all details on lubrication and plugs check our website **tab. 1**
 Per maggiori dettagli su lubrificazione e tappi olio vedi il nostro sito web

RADIAL AND AXIAL LOADS

Output shaft
Albero di uscita

n_2 [min ⁻¹]	F_A [N]	F_R [N]
25	300	1800
15	400	2000

Input shaft
albero in entrata

n_1 [min ⁻¹]	F_A [N]	F_R [N]
1400	20	100

*Strong axial loads in the DX direction are not allowed.
 Non sono consentiti forti carichi assiali con direzione DX

tab. 2

3D dimensions on request

P453FB... Basic wormbox
Riduttore base

Gearbox weight
peso riduttore **3.60 kg**

M. flanges	Kit code	øF	A
56B5	K030.4.041	120	61.5
63B5	K030.4.042	140	62.5
56B14	K030.4.046	80	61.5
63B14	K030.4.045	90	62.5

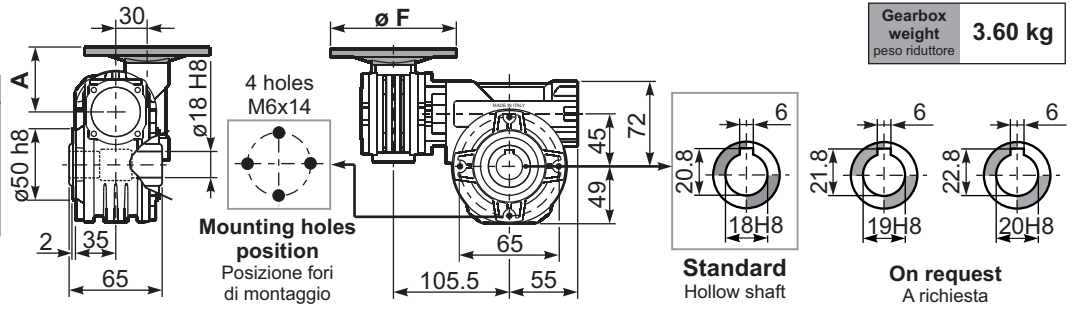

P453PA... Feet
Piedini

P453PB... Feet
Piedini

P453PV... Feet
Piedini

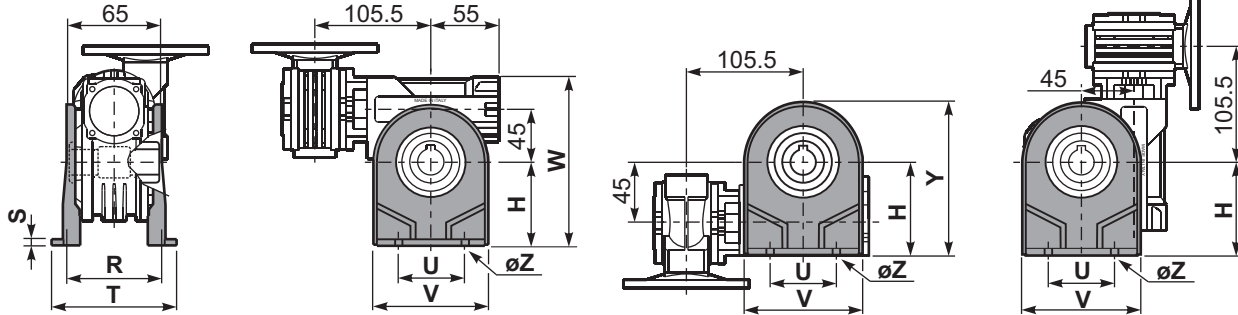

	H	R	S	T	U	V	Y	W	øZ	kit code
type B	72	81	3	100	52	98	121	144	ø10.5	K045.9.022
type S	71	84	8	100	70	90	120	143	ø8	KS045.9.023

P453FC... Output flange
Flangia uscita

P453BR... Reaction arm
Braccio di reazione

kit cod. K045.9.027

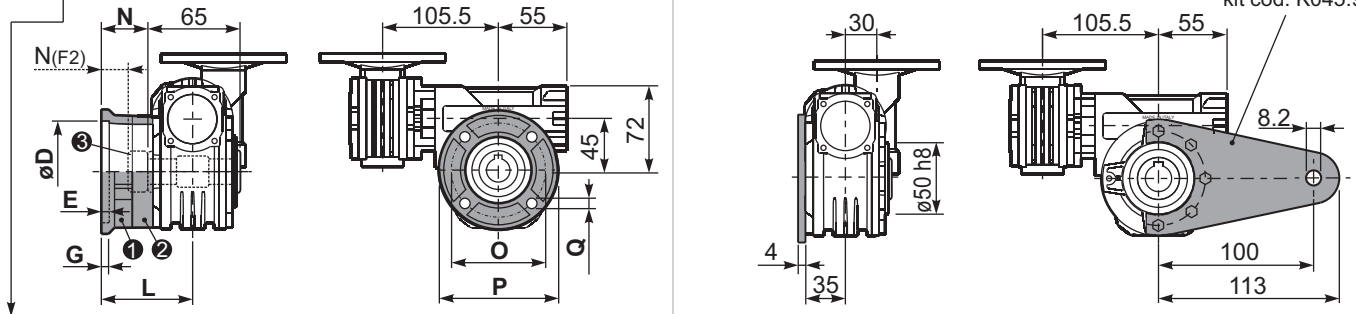

type B	øD	E	G	L	N	O	P	Q	kit code
FC	60 ^{+0.15} / _{+0.05}	9	9	60.5	28	87	110	8.5	① K045.9.010 ② -
FL	60 ^{+0.15} / _{+0.05}	9	9	90.5	58	87	110	8.5	① K045.9.010 ② K045.0.200

type S	øD	E	G	L	N	O	P	Q	kit code
F1	95 ^{+0.20} / _{+0.15}	4	11	73.5	41	115	140	9	① KS045.9.013 ② -
F2	60 ^{+0.15} / _{+0.05}	9	9	60.5	19	87	110	8.5	① KS045.9.010 ② S045.0.204
F3	80 ^{+0.030} / ₀	3	8	51.5	19	100	120	9	① KS045.9.014 ② -

P453.....S... Single Shaft
Albero lento semplice

P453.....D... Double Shaft
Albero lento bisp.

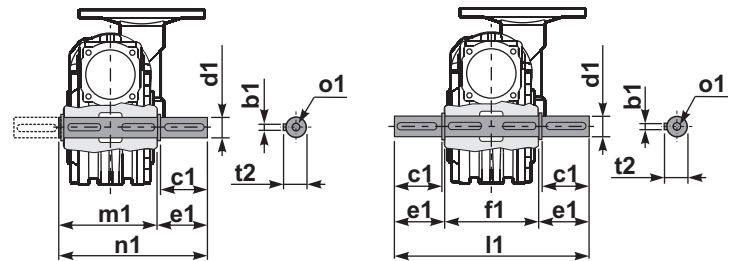

① kit cod. K045.5.028 type B
kit cod. KS045.5.030 type S

② kit cod. K045.5.029 type B
kit cod. KS045.5.031 type S

R453FB... Input shaft
Albero in entrata

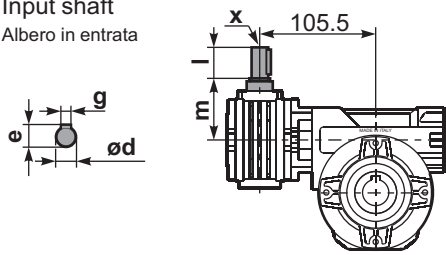

	ød	e	g	l	m	x	kit code
type B	9 h6	10.2	3	20	58	-	① K030.5.006 PAM63 ② -
type S	-	-	-	-	-	-	① - ② -

	b1	c1	d1	e1	f1	l1	m1	n1	t2	o1
type B	6	32	18 ^{-0.005} / _{-0.020}	43	65	151	70	113	20.5	M6x18
type S	6	40	19 ^{-0.005} / _{-0.020}	58.5	65	182	70	128.5	21.5	M8x20

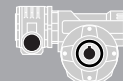

QUICK SELECTION / Selezione veloce

input speed (n_1) = 1400 min⁻¹

Output Speed n_2 [min ⁻¹]	Ratio i	Motor power P_{1M} [kW]	Output torque M_{2M} [Nm]	Service factor f.s.	Nominal power P_{1R} [kW]	Nominal torque M_{2R} [Nm]	Available B5 motor flanges		Available B14 motor flanges		Dynamic efficiency RD	Tooth Module [mm]	Ratios code
							A	B	O	P			
							56	63	56	63			
5.6	252	0.12	97	1.1	0.14	109	B		B-C		47	2.1	01
3.9	360	0.12	124	0.9	0.11	109	B		B-C		42	2.1	02
2.6	540	0.12*	109	<0.8	0.08	109	B		B-C		39	2.1	03
1.9	720	0.12*	109	<0.8	0.06	109	B		B-C		36	2.1	04
1.6	860	0.12*	109	<0.8	0.06	109	B		B-C		32	1.8	05
1.2	1200	0.12*	109	<0.8	0.05	109	B		B-C		27	1.3	06
1.0	1440	0.12*	109	<0.8	0.04	109	B		B-C		26	2.1	07
0.8	1720	0.12*	109	<0.8	0.04	109	B		B-C		25	1.8	08
0.6	2400	0.12*	104	<0.8	0.03	104	B		B-C		21	1.3	09

A) Motor Flanges Available
Flange Motore Disponibili

B) Supplied with Reduction Bushing
Fornito con Bussola di Riduzione

B) Available on Request without reduction bushing
Disponibile a Richiesta senza Bussola di Riduzione



C) Motor Flange Holes Position
Posizione Fori Flangia Motore

* Power higher than the maximum one which can be supported by the gearbox. Select according to the torque M_{2R}
Potenza superiore a quella massima sopportabile dal riduttore. Selezionare in base al momento torcente M_{2R}

EN Unit 503 is supplied with synthetic oil, providing "long life" lubrication. For mounting position V5-V6 please contact us. See table 1 for lubrication and recommended quantity. In table 2 please see possible radial loads and axial loads on the gearbox.

I Il riduttore tipo 503 viene fornito lubrificato a vita con olio sintetico. Per posizioni V5-V6 contattare il ns. servizio tecnico. Vedi tab.1 per oli e quantità consigliati. In tab.2 sono presenti i carichi radiali e assiali applicabili al riduttore.

D Für die Lebensdauerschmierung ist das Getriebe der Größe 503 mit synthetischem Öl befüllt. Bei Einbaulage V5 oder V6 bitten wir um Rücksprache. In Tabelle 1 ist die Schmiermenge und das empfohlene Schmiermittel angegeben. In Tabelle 2 sind die zulässigen Radial- und Axialbelastungen des Getriebes aufgeführt.

F Le réducteur de type 503 est fourni lubrifié à vie avec de l'huile synthétique. Concernant les positions V5.V6, contactez notre service d'assistance technique. Voir tableau 1 concernant les huiles et les quantités conseillées. Les charges radiales et axiales applicables au réducteur sont précisées dans le tableau 2.

E El reductor tamaño 503 se suministra, lubricado de por vida con aceite sintético. Para las posiciones V5 y V6 contactar con nuestro servicio técnico. Ver tabla 1, para cantidades y aceites recomendados. En la tabla 2, se encuentran las cargas radiales y axiales admitidas por el reductor.

LUBRICATION 503 Oil 0.14 Lt.

Quantity 0.14/0.03 Lt. 0.03 Lt.

AGIP Telium VSF 320	SHELL Omala S4 WE 320
----------------------------	------------------------------

For all details on lubrication and plugs check our website **tab. 1**
Per maggiori dettagli su lubrificazione e tappi olio vedi il nostro sito web

RADIAL AND AXIAL LOADS

Output shaft
Albero di uscita

n_2 [min ⁻¹]	FA [N]	FR [N]
25	480	2500
15	560	2800

Input shaft
albero in entrata

n_1 [min ⁻¹]	FA [N]	FR [N]
1400	20	100

*Strong axial loads in the DX direction are not allowed.
Non sono consentiti forti carichi assiali con direzione DX

tab. 2

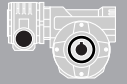

QUICK SELECTION / Selezione veloce

input speed (n_1) = 1400 min⁻¹

Output Speed n_2 [min ⁻¹]	Ratio i	Motor power P_{1M} [kW]	Output torque M_{2M} [Nm]	Service factor f.s.	Nominal power P_{1R} [kW]	Nominal torque M_{2R} [Nm]	Available B5 motor flanges		Available B14 motor flanges		Dynamic efficiency RD	Tooth Module [mm]	Ratios code
							A	B	O	P			
							56	63	56	63			
5.6	252	0.18	142	1.6	0.29	230	B		B-C		46	2.7	01
3.9	360	0.18	181	1.3	0.23	230	B		B-C		41	2.7	02
2.6	540	0.12	164	1.4	0.17	230	B		B-C		37	2.7	03
1.9	720	0.12	200	1.1	0.14	230	B		B-C		34	2.7	04
1.3	1080	0.12	265	0.9	0.10	230	B		B-C		30	2.7	05
1.0	1440	0.12*	230	<0.8	0.09	230	B		B-C		27	2.7	06
0.5	2745	0.12*	230	<0.8	0.05	230	B		B-C		23	2.1	07

A) Motor Flanges Available
Flange Motore Disponibili

B) Supplied with Reduction Bushing
Fornito con Bussola di Riduzione

B) Available on Request without reduction bushing
Disponibile a Richiesta senza Bussola di Riduzione

C) Motor Flange Holes Position
Posizione Fori Flangia Motore

* Power higher than the maximum one which can be supported by the gearbox. Select according to the torque M_{2R}
Potenza superiore a quella massima sopportabile dal riduttore. Selezionare in base al momento torcente M_{2R}

EN Unit 633 is supplied with synthetic oil, providing "long life" lubrication. For mounting position V5-V6 please contact us. See table 1 for lubrication and recommended quantity. In table 2 please see possible radial loads and axial loads on the gearbox.

I Il riduttore tipo 633 viene fornito lubrificato a vita con olio sintetico. Per posizioni V5-V6 contattare il ns. servizio tecnico. Vedi tab.1 per oli e quantità consigliati. In tab.2 sono presenti i carichi radiali e assiali applicabili al riduttore.

D Für die Lebensdauerschmierung ist das Getriebe der Größe 633 mit synthetischem Öl befüllt. Bei Einbaulage V5 oder V6 bitten wir um Rücksprache. In Tabelle 1 ist die Schmiermenge und das empfohlene Schmiermittel angegeben. In Tabelle 2 sind die zulässigen Radial - und Axialbelastungen des Getriebes aufgeführt.

F Le réducteur de type 633 est fourni lubrifié à vie avec de l'huile synthétique. Concernant les positions V5.V6, contactez notre service d'assistance technique. Voir tableau 1 concernant les huiles et les quantités conseillées. Les charges radiales et axiales applicables au réducteur sont précisées dans le tableau 2.

E El reductor tamaño 633 se suministra, lubricado de por vida con aceite sintético. Para las posiciones V5 y V6 contactar con nuestro servicio técnico. Ver tabla 1, para cantidades y aceites recomendados. En la tabla 2, se encuentran las cargas radiales y axiales admitidas por el reductor.

LUBRICATION 633 Oil 0.40 Lt.
Quantity 0.40/0.03 Lt.

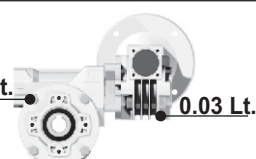

AGIP Telium VSF 320	SHELL Omala S4 WE 320
----------------------------	------------------------------

For all details on lubrication and plugs check our website **tab. 1**
Per maggiori dettagli su lubrificazione e tappi olio vedi il nostro sito web

RADIAL AND AXIAL LOADS

Output shaft
Albero di uscita

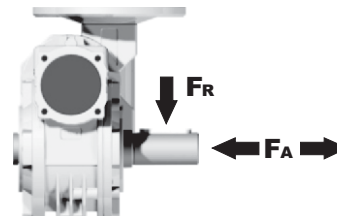

n_2 [min ⁻¹]	FA [N]	FR [N]
25	700	3800
15	800	4000

Input shaft
albero in entrata

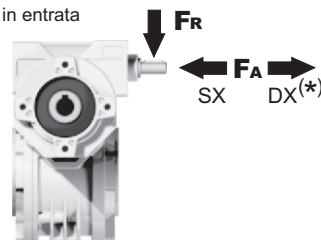

n_1 [min ⁻¹]	FA [N]	FR [N]
1400	20	100

***Strong axial loads in the DX direction are not allowed.**
Non sono consentiti forti carichi assiali con direzione DX

tab. 2

3D dimensions on request

P633FB...

Basic wormbox
Riduttore base

Gearbox weight
peso riduttore 7.50 kg

M. flanges	Kit code	øF	A
56B5	K030.4.041	120	61.5
63B5	K030.4.042	140	62.5
56B14	K030.4.046	80	61.5
63B14	K030.4.045	90	62.5

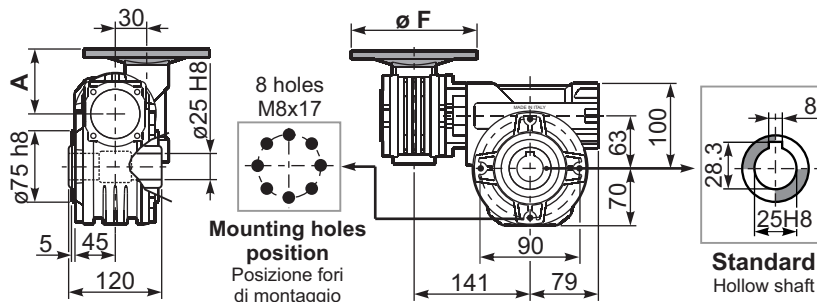

8 holes
M8x17
Mounting holes position
Posizione fori di montaggio

Standard
Hollow shaft

P633PA...

Feet
Piedini

P633PB...

Feet
Piedini

P633PV...

Feet
Piedini

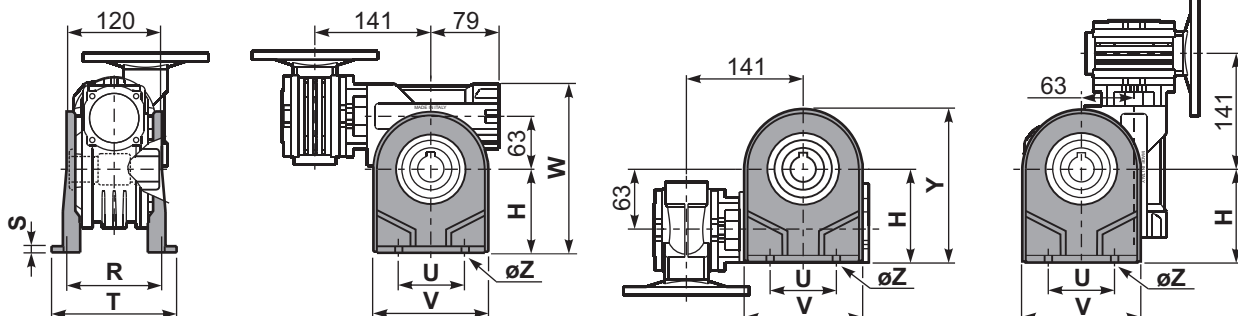

	H	R	S	T	U	V	Y	W	øZ	kit code
type B	100	111	4	144	95	133	170	200	ø10.5	K063.9.022
type S	-	-	-	-	-	-	-	-	-	-

P633FC...

Output flange
Flangia uscita

P633BR...

Reaction arm
Braccio di reazione

kit cod. K063.9.027

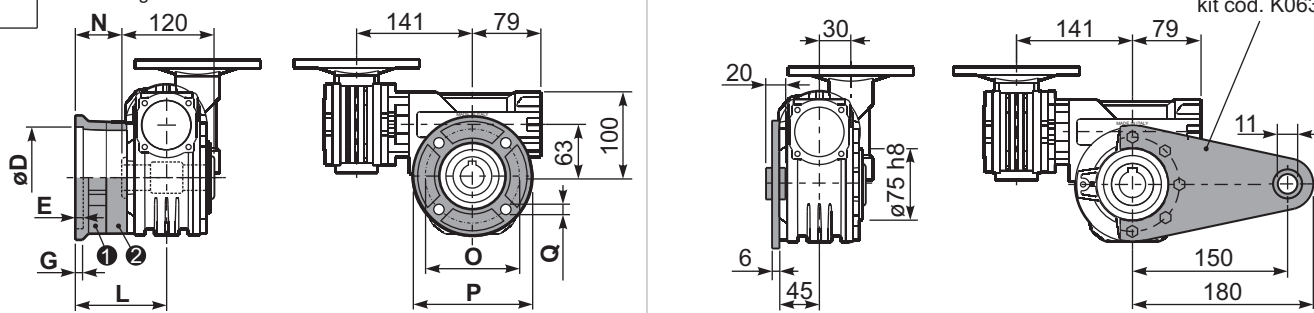

type B	øD	E	G	L	N	O	P	Q	kit code
FC	115 ^{+0.20} / _{+0.15}	7	13	86	26	150	175	11	① K063.9.010 ② -
FL	115 ^{+0.20} / _{+0.15}	7	13	116	56	150	175	11	① K063.9.010 ② K063.0.200
type S	øD	E	G	L	N	O	P	Q	kit code
F1	130 ^{+0.20} / _{+0.15}	7	13	102	42	165	200	13	① KS070.9.013 ② -
F2	115 ^{+0.20} / _{+0.15}	7	13	116	56	150	175	11	① KS063.9.013 ② -
F3	110 ^{+0.035} / ₀	5	11	82	22	130	160	10	① KS063.9.011 ② -

P633.....S...

Single Shaft
Albero lento semplice

P633.....D...

Double Shaft
Albero lento bisp.

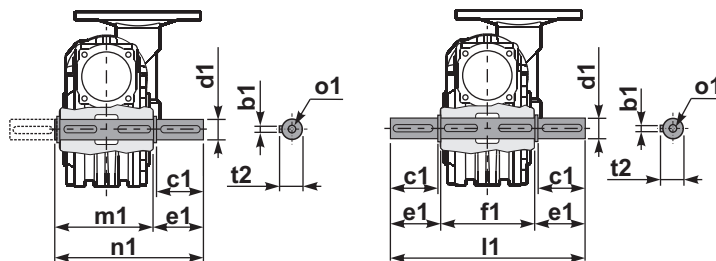

① kit cod. K063.5.028 type B

② kit cod. K063.5.029 type B

R633FB...

Input shaft
Albero in entrata

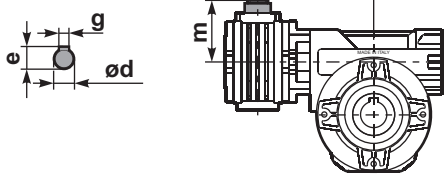

	ød	e	g	l	m	x	kit code
type B	9 h6	10.2	3	20	58	-	① K030.5.006 PAM63 ② -
type S	-	-	-	-	-	-	① - ② -

	b1	c1	d1	e1	f1	l1	m1	n1	t2	o1
type B	8	60	25 ^{-0.005} / _{-0.020}	63.2	120	246.4	126.8	190	28	M8x20
type S	-	-	-	-	-	-	-	-	-	-

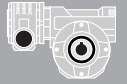

QUICK SELECTION / Selezione veloce

input speed (n_1) = 1400 min⁻¹

Output Speed n_2 [min ⁻¹]	Ratio i	Motor power P_{1M} [kW]	Output torque M_{2M} [Nm]	Service factor f.s.	Nominal power P_{1R} [kW]	Nominal torque M_{2R} [Nm]	Available B5 motor flanges		Available B14 motor flanges			Dynamic efficiency RD	Tooth Module [mm]	 Ratios code
							B	C	O	P	Q			
							63	71	56	63	71			
5.6	252	0.25	198	1.3	0.33	265	B		B-C	B-C		46	2.7	01
3.9	360	0.18	186	1.4	0.26	265	B		B-C	B-C		42	2.7	02
2.8	504	0.18	241	1.1	0.20	265	B		B-C	B-C		39	2.7	03
1.9	756	0.12	204	1.3	0.16	265	B		B-C	B-C		33	2.7	04
1.4	1008	0.12	256	1.0	0.12	265	B		B-C	B-C		31	2.7	05
1.1	1332	0.12*	265	<0.8	0.10	265	B		B-C	B-C		30	2.7	06
0.8	1656	0.12*	265	<0.8	0.08	265	B		B-C	B-C		28	2.7	07
0.6	2160	0.12*	265	<0.8	0.07	265	B		B-C	B-C		26	2.7	08
0.6	2520	0.12*	265	<0.8	0.06	265	B		B-C	B-C		25	2.7	09

Motor Flanges Available
Flange Motore Disponibili

B) Supplied with Reduction Bushing
Fornito con Bussola di Riduzione

B) Available on Request without reduction bushing
Disponibile a Richiesta senza Bussola di Riduzione

C) Motor Flange Holes Position
Posizione Fori Flangia Motore

* Power higher than the maximum one which can be supported by the gearbox. Select according to the torque M_{2R}
Potenza superiore a quella massima sopportabile dal riduttore. Selezionare in base al momento torcente M_{2R}

EN Unit 634 is supplied with synthetic oil, providing "long life" lubrication. For mounting position V5-V6 please contact us. See table 1 for lubrication and recommended quantity. In table 2 please see possible radial loads and axial loads on the gearbox.

I Il riduttore tipo 634 viene fornito lubrificato a vita con olio sintetico. Per posizioni V5-V6 contattare il ns. servizio tecnico. Vedi tab.1 per oli e quantità consigliati. In tab.2 sono presenti i carichi radiali e assiali applicabili al riduttore.

D Für die Lebensdauerschmierung ist das Getriebe der Größe 634 mit synthetischem Öl befüllt. Bei Einbaulage V5 oder V6 bitten wir um Rücksprache. In Tabelle 1 ist die Schmiermenge und das empfohlene Schmiermittel angegeben. In Tabelle 2 sind die zulässigen Radial- und Axialbelastungen des Getriebes aufgeführt.

F Le réducteur de type 634 est fourni lubrifié à vie avec de l'huile synthétique. Concernant les positions V5.V6, contactez notre service d'assistance technique. Voir tableau 1 concernant les huiles et les quantités conseillées. Les charges radiales et axiales applicables au réducteur sont précisées dans le tableau 2.

E El reductor tamaño 634 se suministra, lubricado de por vida con aceite sintético. Para las posiciones V5 y V6 contactar con nuestro servicio técnico. Ver tabla 1, para cantidades y aceites recomendados. En la tabla 2, se encuentran las cargas radiales y axiales admitidas por el reductor.

LUBRICATION 634 Oil **Quantity 0.40/0.09 Lt.**

AGIP Telium VSF 320 **SHELL** Omala S4 WE 320

For all details on lubrication and plugs check our website **tab. 1**
Per maggiori dettagli su lubrificazione e tappi olio vedi il nostro sito web

RADIAL AND AXIAL LOADS

Output shaft
Albero di uscita

n_2 [min ⁻¹]	FA [N]	FR [N]
25	700	3800
15	800	4000

Input shaft
albero in entrata

n_1 [min ⁻¹]	FA [N]	FR [N]
1400	42	210

***Strong axial loads in the DX direction are not allowed.**
Non sono consentiti forti carichi assiali con direzione DX

tab. 2

3D dimensions on request

P634FB...

Basic wormbox
Riduttore base

Gearbox weight
peso riduttore **8.90 kg**

M. flanges	Kit code	øF	A
63B5	K050.4.041	138	74
71B5	K050.4.042	160	71.5
56B14	KC40.4.049	80	71.5
63B14	K050.4.047	90	74
71B14	K050.4.045	105	71.5

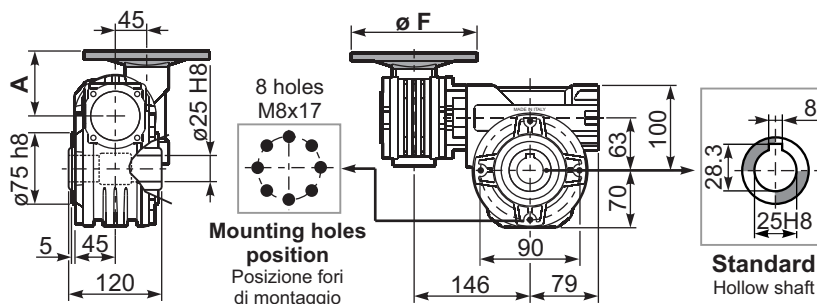

Mounting holes position
Posizione fori di montaggio

Standard
Hollow shaft

P634PA...

Feet
Piedini

P634PB...

Feet
Piedini

P634PV...

Feet
Piedini

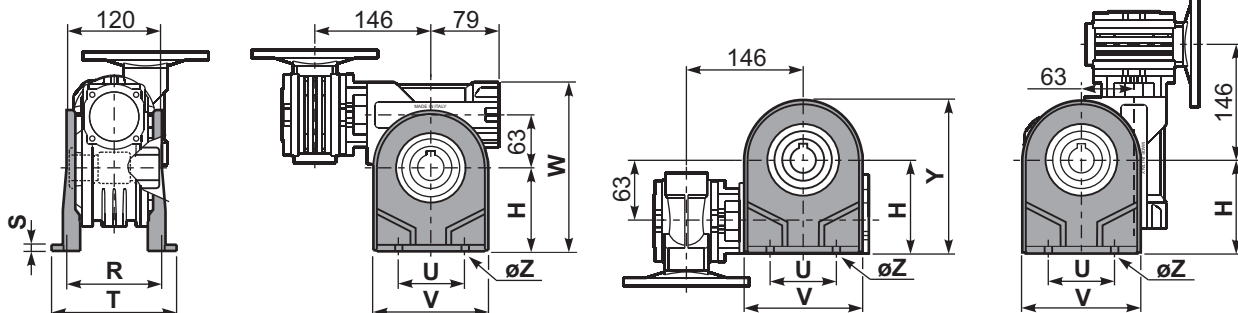

	H	R	S	T	U	V	Y	W	øZ	kit code
type B	100	111	4	144	95	133	170	200	ø10.5	K063.9.022
type S	-	-	-	-	-	-	-	-	-	-

P634FC...

Output flange
Flangia uscita

P634BR...

Reaction arm
Braccio di reazione

kit cod. K063.9.027

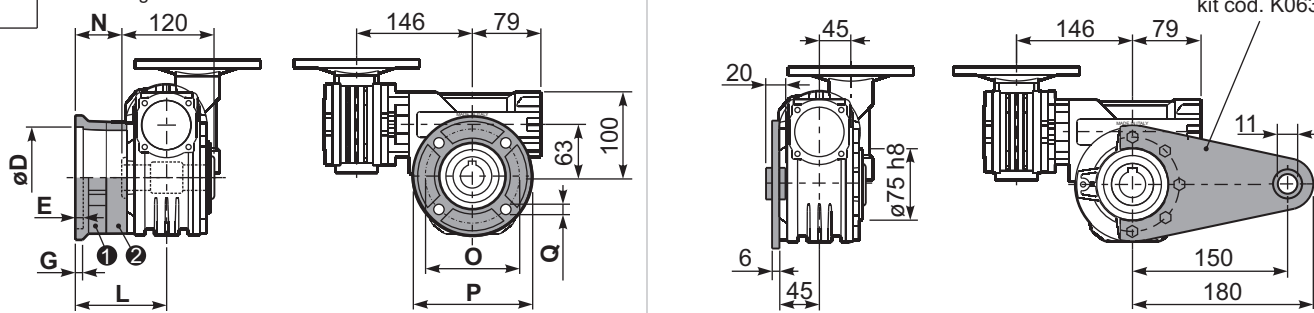

type B	øD	E	G	L	N	O	P	Q	kit code
FC	115 ^{+0.20} / _{+0.15}	7	13	86	26	150	175	11	① K063.9.010 ② -
FL	115 ^{+0.20} / _{+0.15}	7	13	116	56	150	175	11	① K063.9.010 ② K063.0.200

type S	øD	E	G	L	N	O	P	Q	kit code
F1	130 ^{+0.20} / _{+0.15}	7	13	102	42	165	200	13	① KS070.9.013 ② -
F2	115 ^{+0.20} / _{+0.15}	7	13	116	56	150	175	11	① KS063.9.013 ② -
F3	110 ^{+0.035} / ₀	5	11	82	22	130	160	10	① KS063.9.011 ② -

P634.....S...

Single Shaft
Albero lento semplice

P634.....D...

Double Shaft
Albero lento bisp.

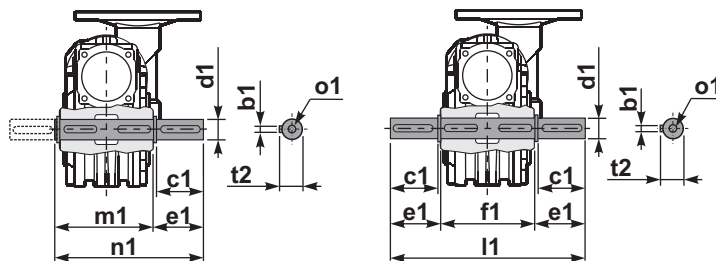

① kit cod. K063.5.028 type B

② kit cod. K063.5.029 type B

R634FB...

Input shaft
Albero in entrata

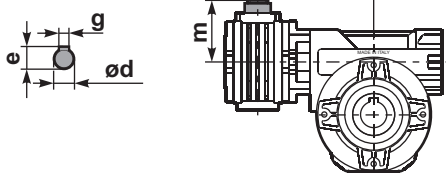

	ød	e	g	l	m	x	kit code
type B	11 h6	12.5	4	30	68	-	① ② K045.5.006 PAM71
type S	-	-	-	-	-	-	① ② -

	b1	c1	d1	e1	f1	l1	m1	n1	t2	o1
type B	8	60	25 ^{-0.005} / _{-0.020}	63.2	120	246.4	126.8	190	28	M8x20
type S	-	-	-	-	-	-	-	-	-	-

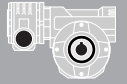

QUICK SELECTION / Selezione veloce

input speed (n_1) = 1400 min⁻¹

Output Speed n_2 [min ⁻¹]	Ratio i	Motor power P_{1M} [kW]	Output torque M_{2M} [Nm]	Service factor f.s.	Nominal power P_{1R} [kW]	Nominal torque M_{2R} [Nm]	Available B5 motor flanges		Available B14 motor flanges		Dynamic efficiency RD	Tooth Module [mm]	Ratios code
							A	B	O	P			
							56	63	56	63			
5.6	252	0.18	142	2.0	0.37	290	B		B-C		46	2.7	01
3.9	360	0.18	181	1.6	0.29	290	B		B-C		41	2.7	02
2.6	540	0.18	245	1.2	0.21	290	B		B-C		37	2.7	03
1.9	720	0.12	200	1.4	0.17	290	B		B-C		34	2.7	04
1.3	1080	0.12	265	1.1	0.13	290	B		B-C		30	2.7	05
1.0	1440	0.12	318	0.9	0.11	290	B		B-C		27	2.7	06
0.5	2745	0.12*	242	<0.8	0.06	242	B		B-C		23	2.1	07

A) Motor Flanges Available
Flange Motore Disponibili

B) Supplied with Reduction Bushing
Fornito con Bussola di Riduzione

B) Available on Request without reduction bushing
Disponibile a Richiesta senza Bussola di Riduzione

C) Motor Flange Holes Position
Posizione Fori Flangia Motore

* Power higher than the maximum one which can be supported by the gearbox. Select according to the torque M_{2R}
Potenza superiore a quella massima sopportabile dal riduttore. Selezionare in base al momento torcente M_{2R}

EN Unit **6A3** is supplied with synthetic oil, providing "long life" lubrication. For mounting position V5-V6 please contact us. See table 1 for lubrication and recommended quantity. In table 2 please see possible radial loads and axial loads on the gearbox.

I Il riduttore tipo **6A3** viene fornito lubrificato a vita con olio sintetico. Per posizioni V5-V6 contattare il ns. servizio tecnico. Vedi tab.1 per oli e quantità consigliati. In tab.2 sono presenti i carichi radiali e assiali applicabili al riduttore.

D Für die Lebensdauerschmierung ist das Getriebe der Größe **6A3** mit synthetischem Öl befüllt. Bei Einbaulage V5 oder V6 bitten wir um Rücksprache. In Tabelle 1 ist die Schmiermenge und das empfohlene Schmiermittel angegeben. In Tabelle 2 sind die zulässigen Radial - und Axialbelastungen des Getriebes aufgeführt.

F Le réducteur de type **6A3** est fourni lubrifié à vie avec de l'huile synthétique. Concernant les positions V5.V6, contactez notre service d'assistance technique. Voir tableau 1 concernant les huiles et les quantités conseillées. Les charges radiales et axiales applicables au réducteur sont précisées dans le tableau 2.

E El reductor tamaño **6A3** se suministra, lubricado de por vida con aceite sintético. Para las posiciones V5 y V6 contactar con nuestro servicio técnico. Ver tabla 1, para cantidades y aceites recomendados. En la tabla 2, se encuentran las cargas radiales y axiales admitidas por el reductor.

LUBRICATION 6A3 Oil **Quantity 0.40/0.06 Lt.**

AGIP Telium VSF 320

SHELL Omala S4 WE 320

For all details on lubrication and plugs check our website **tab. 1**
Per maggiori dettagli su lubrificazione e tappi olio vedi il nostro sito web

RADIAL AND AXIAL LOADS

Output shaft
Albero di uscita

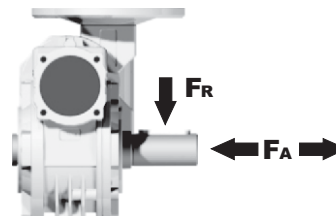

n_2 [min ⁻¹]	FA [N]	FR [N]
25	700	3800
15	800	4000

Input shaft
albero in entrata

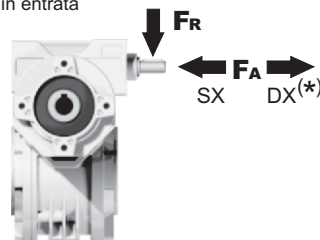

n_1 [min ⁻¹]	FA [N]	FR [N]
1400	20	100

*Strong axial loads in the DX direction are not allowed.
Non sono consentiti forti carichi assiali con direzione DX

tab. 2

3D dimensions on request

P6A3FB... Basic wormbox
Riduttore base

M. flanges	Kit code	øF	A
56B5	K030.4.041	120	61.5
63B5	K030.4.042	140	62.5
56B14	K030.4.046	80	61.5
63B14	K030.4.045	90	62.5

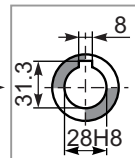
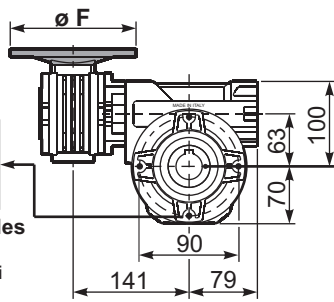
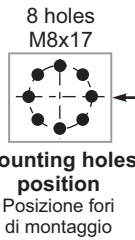
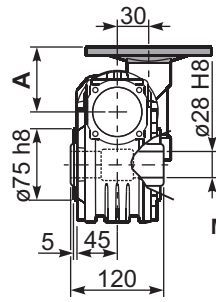

Standard
Hollow shaft

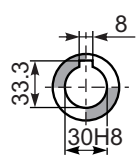

On request
A richiesta

Gearbox weight
peso riduttore **8.90 kg**

P6A3PA... Feet
Piedini

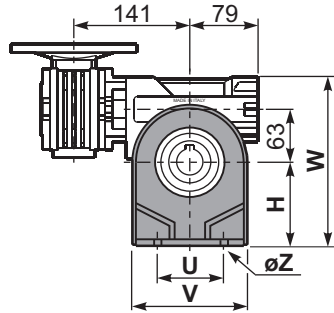
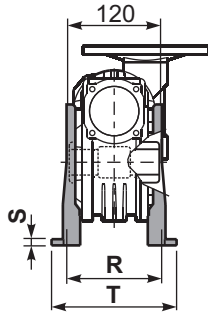

P6A3PB... Feet
Piedini

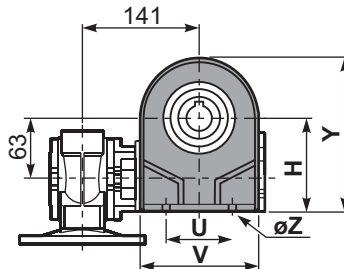

P6A3PV... Feet
Piedini

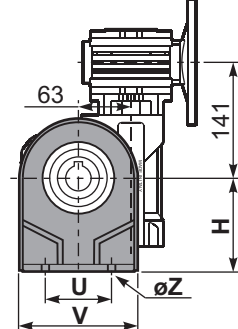

	H	R	S	T	U	V	Y	W	øZ	kit code
type B	115	115	12	142	120	156	185	215	ø11	K070.9.022
type S	-	-	-	-	-	-	-	-	-	-

P6A3FC... Output flange
Flangia uscita

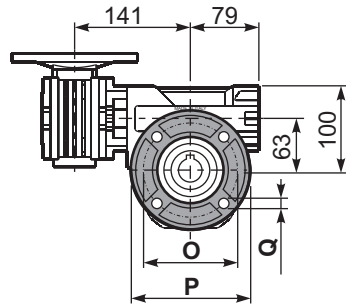
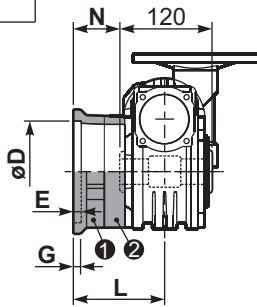

type B	øD	E	G	L	N	O	P	Q	kit code
FC	130 ^{+0.20} / _{+0.15}	7	13	85	25	165	200	13	① K070.9.010 ② -
FL	130 ^{+0.20} / _{+0.15}	7	13	111	51	165	200	13	① K070.9.010 ② K070.0.200
type S	øD	E	G	L	N	O	P	Q	kit code
F1	130 ^{+0.20} / _{+0.15}	7	13	111	51	165	200	13	① KS070.9.014 ② -
F2	115 ^{+0.20} / _{+0.15}	7	13	116	56	150	175	11	① KS063.9.013 ② -
F3	110 ^{+0.035} / ₀	5	13.5	84.5	24.5	130	160	11	① KS070.9.011 ② -

P6A3BR... Reaction arm
Braccio di reazione

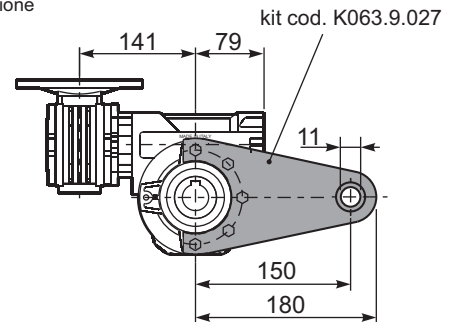
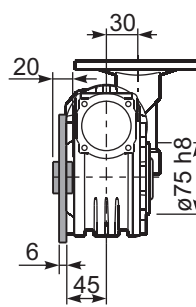

P6A3....S... Single Shaft
Albero lento semplice

P6A3....D... Double Shaft
Albero lento bisp.

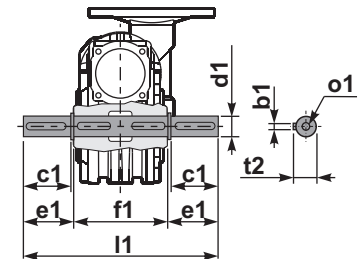
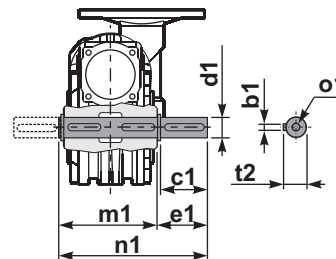

① kit cod. K070.5.028 type B

② kit cod. K070.5.029 type B

R6A3FB... Input shaft
Albero in entrata

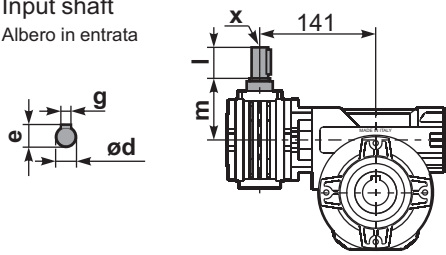

	ød	e	g	l	m	x	kit code
type B	9 h6	10.2	3	20	58	-	① K030.5.006 PAM63 ② -
type S	-	-	-	-	-	-	① - ② -

	b1	c1	d1	e1	f1	l1	m1	n1	t2	o1
type B	8	60	28 ^{-0.005} / _{-0.020}	63.5	120	247	127.5	191	31	M8x20
type S	-	-	-	-	-	-	-	-	-	-

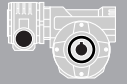

QUICK SELECTION / Selezione veloce

input speed (n_1) = 1400 min⁻¹

Output Speed n_2 [min ⁻¹]	Ratio i	Motor power P_{1M} [kW]	Output torque M_{2M} [Nm]	Service factor f.s.	Nominal power P_{1R} [kW]	Nominal torque M_{2R} [Nm]	Available B5 motor flanges		Available B14 motor flanges			Dynamic efficiency RD	Tooth Module [mm]	Ratios code
							B	C	O	P	Q			
							63	71	56	63	71			
5.6	252	0.25	198	1.5	0.38	304	B		B-C	B-C		46	2.7	01
3.9	360	0.25	258	1.2	0.29	304	B		B-C	B-C		42	2.7	02
2.8	504	0.18	241	1.3	0.23	304	B		B-C	B-C		39	2.7	03
1.9	756	0.12	204	1.5	0.18	304	B		B-C	B-C		33	2.7	04
1.4	1008	0.12	256	1.2	0.14	304	B		B-C	B-C		31	2.7	05
1.1	1332	0.12	327	0.9	0.11	304	B		B-C	B-C		30	2.7	06
0.8	1656	0.12*	304	<0.8	0.10	304	B		B-C	B-C		28	2.7	07
0.6	2160	0.12*	304	<0.8	0.08	304	B		B-C	B-C		26	2.7	08
0.6	2520	0.12*	304	<0.8	0.07	304	B		B-C	B-C		25	2.7	09

A) Motor Flanges Available
Flange Motore Disponibili

B) Supplied with Reduction Bushing
Fornito con Bussola di Riduzione

B) Available on Request without reduction bushing
Disponibile a Richiesta senza Bussola di Riduzione

C) Motor Flange Holes Position
Posizione Fori Flangia Motore

* Power higher than the maximum one which can be supported by the gearbox. Select according to the torque M_{2R}
Potenza superiore a quella massima sopportabile dal riduttore. Selezionare in base al momento torcente M_{2R}

EN Unit **6A4** is supplied with synthetic oil, providing "long life" lubrication. For mounting position V5-V6 please contact us. See table 1 for lubrication and recommended quantity. In table 2 please see possible radial loads and axial loads on the gearbox.

I Il riduttore tipo **6A4** viene fornito lubrificato a vita con olio sintetico. Per posizioni V5-V6 contattare il ns. servizio tecnico. Vedi tab.1 per oli e quantità consigliati. In tab.2 sono presenti i carichi radiali e assiali applicabili al riduttore.

D Für die Lebensdauerschmierung ist das Getriebe der Größe **6A4** mit synthetischem Öl befüllt. Bei Einbaulage V5 oder V6 bitten wir um Rücksprache. In Tabelle 1 ist die Schmiermenge und das empfohlene Schmiermittel angegeben. In Tabelle 2 sind die zulässigen Radial- und Axialbelastungen des Getriebes aufgeführt.

F Le réducteur de type **6A4** est fourni lubrifié à vie avec de l'huile synthétique. Concernant les positions V5.V6, contactez notre service d'assistance technique. Voir tableau 1 concernant les huiles et les quantités conseillées. Les charges radiales et axiales applicables au réducteur sont précisées dans le tableau 2.

E El reductor tamaño **6A4** se suministra, lubricado de por vida con aceite sintético. Para las posiciones V5 y V6 contactar con nuestro servicio técnico. Ver tabla 1, para cantidades y aceites recomendados. En la tabla 2, se encuentran las cargas radiales y axiales admitidas por el reductor.

■ LUBRICATION 6A4 Oil 0.40 Lt. 0.09 Lt.

Quantity 0.40/0.09 Lt.

AGIP Telium VSF 320	SHELL Omala S4 WE 320
----------------------------	------------------------------

For all details on lubrication and plugs check our website tab. 1
Per maggiori dettagli su lubrificazione e tappi olio vedi il nostro sito web

■ RADIAL AND AXIAL LOADS

Output shaft
Albero di uscita

n_2 [min ⁻¹]	FA [N]	FR [N]
25	700	3800
15	800	4000

Input shaft
albero in entrata

n_1 [min ⁻¹]	FA [N]	FR [N]
1400	42	210

*Strong axial loads in the DX direction are not allowed.
Non sono consentiti forti carichi assiali con direzione DX

tab. 2

3D dimensions on request

P6A4FB... Basic wormbox
Riduttore base

M. flanges	Kit code	øF	A
63B5	K050.4.041	138	74
71B5	K050.4.042	160	71.5
56B14	KC40.4.049	80	71.5
63B14	K050.4.047	90	74
71B14	K050.4.045	105	71.5

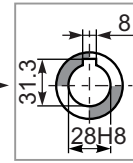
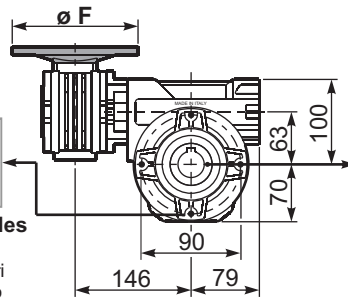
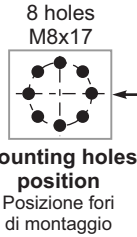
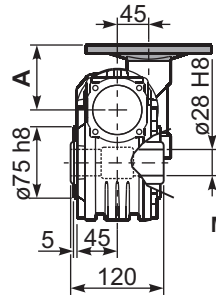

Standard
Hollow shaft

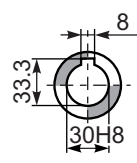

On request
A richiesta

Gearbox weight
peso riduttore **8.90 kg**

P6A4PA... Feet
Piedini

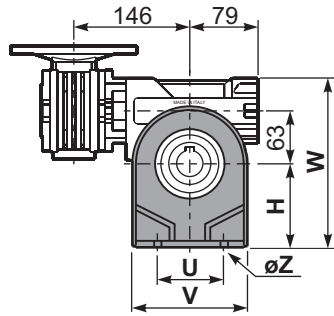
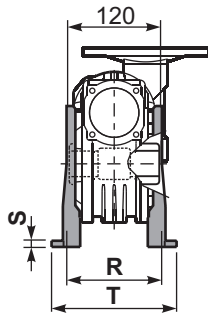

P6A4PB... Feet
Piedini

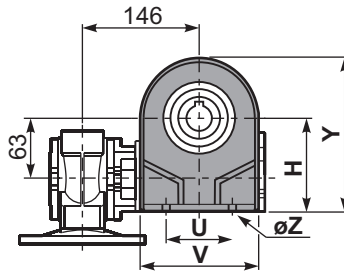

P6A4PV... Feet
Piedini

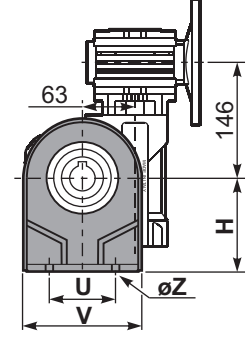

	H	R	S	T	U	V	Y	W	øZ	kit code
type B	115	115	12	142	120	156	185	215	ø11	K070.9.022
type S	-	-	-	-	-	-	-	-	-	-

P6A4FC... Output flange
Flangia uscita

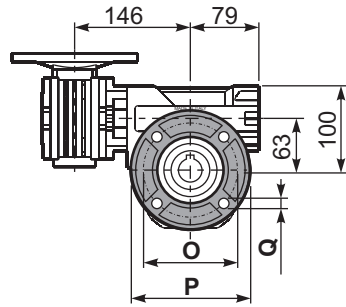
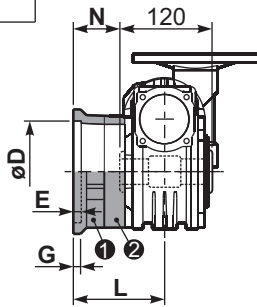

type B	øD	E	G	L	N	O	P	Q	kit code
FC	130 ^{+0.20} / _{+0.15}	7	13	85	25	165	200	13	1 K070.9.010 2 -
FL	130 ^{+0.20} / _{+0.15}	7	13	111	51	165	200	13	1 K070.9.010 2 K070.0.200
type S	øD	E	G	L	N	O	P	Q	kit code
F1	130 ^{+0.20} / _{+0.15}	7	13	111	51	165	200	13	1 KS070.9.014 2 -
F2	115 ^{+0.20} / _{+0.15}	7	13	116	56	150	175	11	1 KS063.9.013 2 -
F3	110 ^{+0.035} / ₀	5	13.5	84.5	24.5	130	160	11	1 KS070.9.011 2 -

P6A4BR... Reaction arm
Braccio di reazione

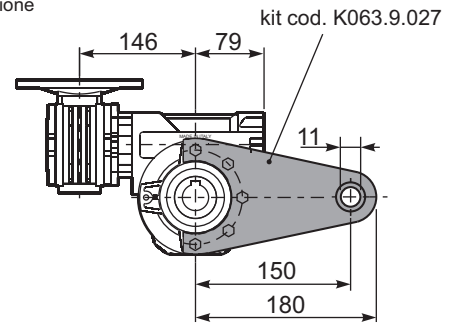
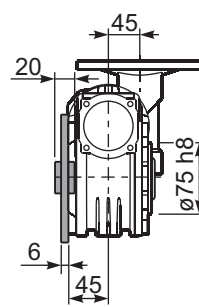

P6A4....S... Single Shaft
Albero lento semplice

P6A4....D... Double Shaft
Albero lento bisp.

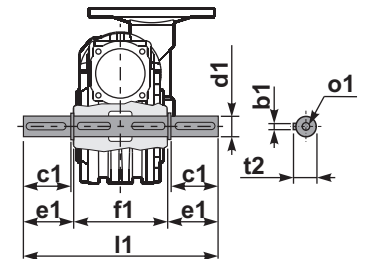
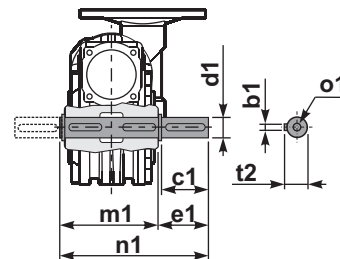

1 kit cod. K070.5.028 type B

2 kit cod. K070.5.029 type B

R6A4FB... Input shaft
Albero in entrata

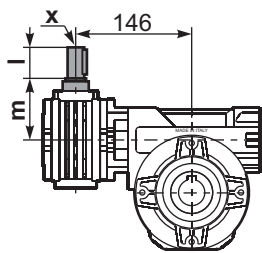
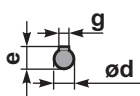

	ød	e	g	l	m	x	kit code
type B	11 h6	12.5	4	30	68	-	1 2 K045.5.006 PAM71
type S	-	-	-	-	-	-	1 2 -

	b1	c1	d1	e1	f1	l1	m1	n1	t2	o1
type B	8	60	28 ^{-0.005} / _{-0.020}	63.5	120	247	127.5	191	31	M8x20
type S	-	-	-	-	-	-	-	-	-	-

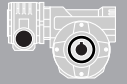

QUICK SELECTION / Selezione veloce

input speed (n_1) = 1400 min⁻¹

Output Speed n_2 [min ⁻¹]	Ratio i	Motor power P_{1M} [kW]	Output torque M_{2M} [Nm]	Service factor f.s.	Nominal power P_{1R} [kW]	Nominal torque M_{2R} [Nm]	Available B5 motor flanges		Available B14 motor flanges			Dynamic efficiency RD	Tooth Module [mm]	Ratios code
							B	C	O	P	Q			
							63	71	56	63	71			
10	140	0.37	205	1.8	0.66	368	B		B-C	B-C		58	4.5	01
7.1	196	0.37	257	1.4	0.53	368	B		B-C	B-C		52	4.7	02
5.0	280	0.37	332	1.6	0.58	518	B		B-C	B-C		47	4.7	03
3.6	392	0.37	435	1.2	0.44	518	B		B-C	B-C		44	4.7	04
2.4	588	0.25	371	1.4	0.35	518	B		B-C	B-C		37	4.7	05
1.8	784	0.25	455	1.1	0.28	518	B		B-C	B-C		34	4.7	06
1.4	1036	0.18	420	1.2	0.22	518	B		B-C	B-C		33	4.7	07
1.1	1288	0.18	474	1.1	0.20	518	B		B-C	B-C		30	4.7	08
0.7	1960	0.12	449	1.2	0.14	518	B		B-C	B-C		28	4.7	09
0.5	2856	0.12	584	0.9	0.11	518	B		B-C	B-C		25	4.7	10

A Motor Flanges Available
Flange Motore Disponibili

B Supplied with Reduction Bushing
Fornito con Bussola di Riduzione

B Available on Request without reduction bushing
Disponibile a Richiesta senza Bussola di Riduzione

C Motor Flange Holes Position
Posizione Fori Flangia Motore

EN Unit **854** is supplied with synthetic oil, providing "long life" lubrication. For mounting position V5-V6 please contact us. See table 1 for lubrication and recommended quantity. In table 2 please see possible radial loads and axial loads on the gearbox.

I Il riduttore tipo **854** viene fornito lubrificato a vita con olio sintetico. Per posizioni V5-V6 contattare il ns. servizio tecnico. Vedi tab.1 per oli e quantità consigliati. In tab.2 sono presenti i carichi radiali e assiali applicabili al riduttore.

D Für die Lebensdauerschmierung ist das Getriebe der Größe **854** mit synthetischem Öl befüllt. Bei Einbaulage V5 oder V6 bitten wir um Rücksprache. In Tabelle 1 ist die Schmiermenge und das empfohlene Schmiermittel angegeben. In Tabelle 2 sind die zulässigen Radial- und Axialbelastungen des Getriebes aufgeführt.

F Le réducteur de type **854** est fourni lubrifié à vie avec de l'huile synthétique. Concernant les positions V5.V6, contactez notre service d'assistance technique. Voir tableau 1 concernant les huiles et les quantités conseillées. Les charges radiales et axiales applicables au réducteur sont précisées dans le tableau 2.

E El reductor tamaño **854** se suministra, lubricado de por vida con aceite sintético. Para las posiciones V5 y V6 contactar con nuestro servicio técnico. Ver tabla 1, para cantidades y aceites recomendados. En la tabla 2, se encuentran las cargas radiales y axiales admitidas por el reductor.

LUBRICATION 854 Oil **1.2 Lt.**

Quantity 1.2/0.09 Lt.

AGIP Telium VSF 320

SHELL Omala S4 WE 320

For all details on lubrication and plugs check our website **tab. 1**
Per maggiori dettagli su lubrificazione e tappi olio vedi il nostro sito web

RADIAL AND AXIAL LOADS

Output shaft

Albero di uscita

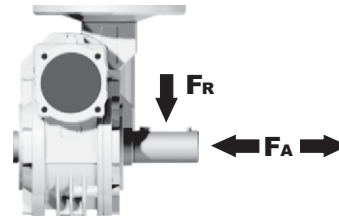

n_2 [min ⁻¹]	FA [N]	FR [N]
25	1000	5000
15	1160	5800

Input shaft

albero in entrata

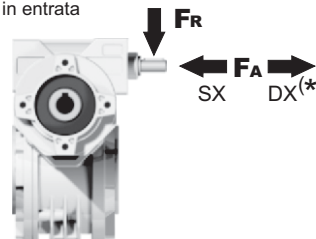

n_1 [min ⁻¹]	FA [N]	FR [N]
1400	42	210

***Strong axial loads in the DX direction are not allowed.**
Non sono consentiti forti carichi assiali con direzione DX

tab. 2

3D dimensions on request

P854FB... Basic wormbox
Riduttore base

M. flanges	Kit code	øF	A
63B5	K050.4.041	138	74
71B5	K050.4.042	160	71.5
56B14	KC40.4.049	80	71.5
63B14	K050.4.047	90	74
71B14	K050.4.045	105	71.5

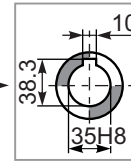
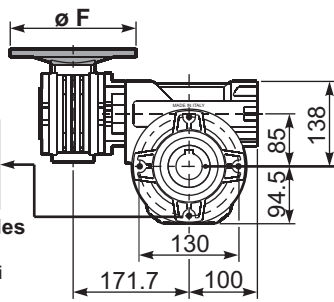
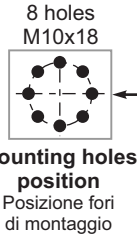
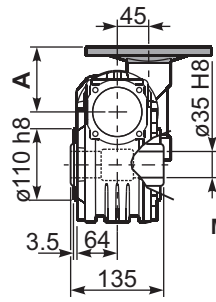

Standard
Hollow shaft

Gearbox weight
peso riduttore **19.50 kg**

P854PA... Feet
Piedini

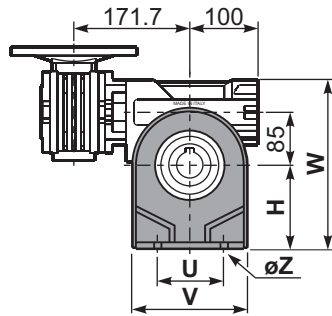
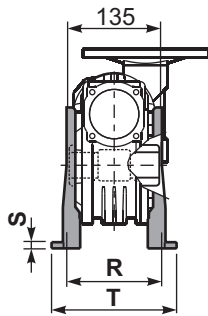

P854PB... Feet
Piedini

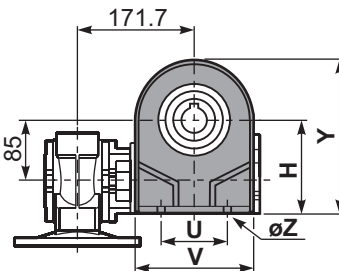

P854PV... Feet
Piedini

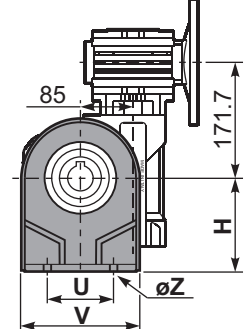

	H	R	S	T	U	V	Y	W	øZ	kit code
type B	142	145	5	182	140	180	236.5	280	ø10.5	K085.9.022
type S	-	-	-	-	-	-	-	-	-	-

P854FC... Output flange
Flangia uscita

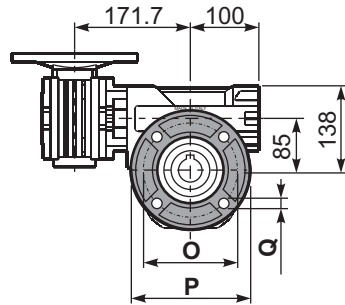
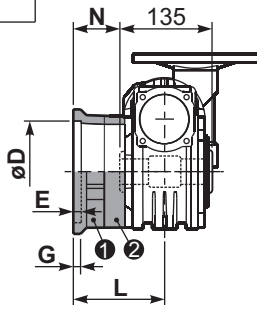

P854BR... Reaction arm
Braccio di reazione

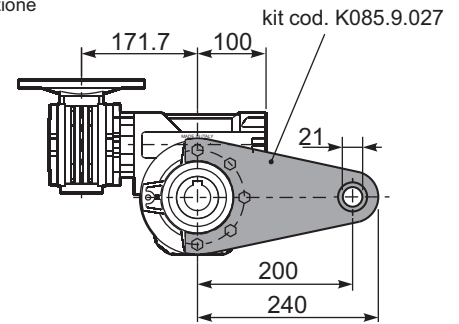
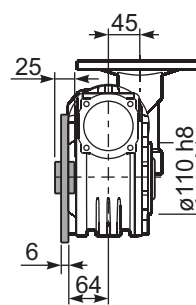

type B	øD	E	G	L	N	O	P	Q	kit code
FC	152 ^{+0.06} / _{+0.00}	5	16	108	40.5	176	205	13	1, 2 K085.9.010
FL	152 ^{+0.06} / _{+0.00}	5	16	148.5	81	176	205	13	1, 2 K085.9.010 2 K085.0.201

type S	øD	E	G	L	N	O	P	Q	kit code
F1	130 ^{+0.040} / ₀	5	13	117.5	50	165	200	11.5	1, 2 KS085.9.012
F2	152 ^{+0.06} / ₀	5	15	147.5	80	180	205	12.5	1, 2 KS085.9.013
F4	130 ^{+0.040} / ₀	5	13	106.5	39	165	200	13	1, 2 KS085.9.015

P854.....S... Single Shaft
Albero lento semplice

P854.....D... Double Shaft
Albero lento bisp.

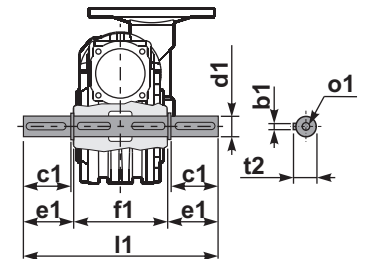
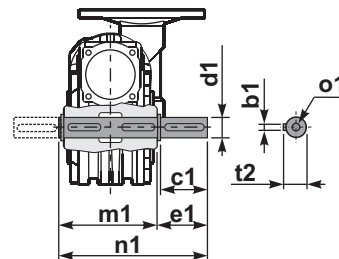

1 kit cod. K085.5.028 type B

2 kit cod. K085.5.029 type B

R854FB... Input shaft
Albero in entrata

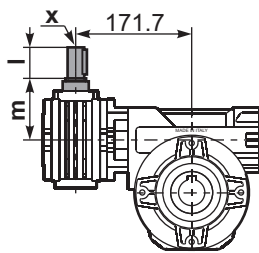
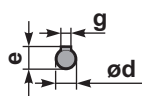

	ød	e	g	l	m	x	kit code
type B	11 h6	12.5	4	30	68	-	1, 2 K045.5.006 PAM71
type S	-	-	-	-	-	-	1, 2 -

	b1	c1	d1	e1	f1	l1	m1	n1	t2	o1
type B	10	60	35 ^{-0.005} / _{-0.020}	73.5	135	282	141	214.5	38	M10x23
type S	-	-	-	-	-	-	-	-	-	-

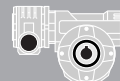

QUICK SELECTION / Selezione veloce

input speed (n_1) = 1400 min⁻¹

Output Speed n_2 [min ⁻¹]	Ratio i	Motor power P_{1M} [kW]	Output torque M_{2M} [Nm]	Service factor f.s.	Nominal power P_{1R} [kW]	Nominal torque M_{2R} [Nm]	Available B5 motor flanges			Available B14 motor flanges				Dynamic efficiency RD	Tooth Module [mm]	Ratios code
							B	C	D	O	P	Q	R			
							63	71	80	56	63	71	80			
6.7	210	0.75	591	1.5	1.1	863	B	B			B-C	B		55	5.6	01
4.7	300	0.75	752	1.3	0.97	978	B	B			B-C	B		49	5.6	02
3.3	420	0.55	741	1.3	0.73	978	B	B			B-C	B		47	5.6	03
2.6	540	0.55	851	1.1	0.63	978	B	B			B-C	B		42	5.6	04
1.8	780	0.37	748	1.3	0.48	978	B	B			B-C	B		38	5.6	05
1.3	1080	0.37	1009	1.0	0.36	978	B			B-C	B-C			37	5.6	06
1.1	1290	0.25	770	1.3	0.32	978	B			B-C	B-C			35	5.6	07
0.8	1800	0.25	921	1.1	0.27	978	B			B-C	B-C			30	5.6	08
0.7	2040	0.18	751	1.3	0.23	978	B			B-C	B-C			30	5.6	09
0.6	2400	0.18	825	1.2	0.21	978	B			B-C	B-C			28	5.6	10
0.5	3000	0.18	958	1.0	0.18	978	B			B-C	B-C			26	5.6	11

Motor Flanges Available
Flange Motore Disponibili

B) Supplied with Reduction Bushing
Fornito con Bussola di Riduzione

B) Available on Request without reduction bushing
Disponibile a Richiesta senza Bussola di Riduzione

C) Motor Flange Holes Position
Posizione Fori Flangia Motore

EN Unit 115 is supplied without lubricant and equipped with a breather, level and drain plugs. User can add mineral oil keeping existing plugs. Should the user wish to fill it with synthetic oil, it is recommended to replace the existing plugs with a type that are closed. Gearbox 050 is supplied lubricated for life. See tab.1 for oils and recommended quantity. In tab.2 there are radial loads and axial loads applicable to the gearbox.

I Il riduttore tipo 115 è fornito privo di lubrificazione con tappi di sfiato, livello e scarico olio. L'utente può immettere olio minerale mantenendo i tappi esistenti. Se immetterà olio sintetico, dovrà sostituire i tappi esistenti con altri tipo chiuso. Il riduttore 050 è fornito lubrificato a vita con olio sintetico. Tab.1 per oli e quantità consigliati. Tab.2 carichi radiali e assiali applicabili al riduttore.

D Das Getriebe der Baugröße 115 wird ohne Schmiermittel geliefert. Es ist jedoch mit Einfüllschraube, Überdruckventil und Ablassschraube ausgerüstet. Das benötigte mineralische Öl kann über die Einfüllschraube eingefüllt werden. Sollte synthetisches Öl bevorzugt werden, so ist sind das eingebaute Überdruckventil durch eine geschlossenen Schraube zu ersetzen. Das Getriebe der Baugröße 050 ist lebensdauer geschmiert. In Tabelle 1 ist die Schmiermenge und das empfohlene Schmiermittel angegeben. In Tabelle 2 sind die zulässigen Radial - und Axialbelastungen des Getriebes aufgeführt.

F Le réducteur de type 115 est fourni sans lubrification et avec un bouchon de remplissage, de niveau et d'évacuation de l'huile. L'utilisateur peut y verser de l'huile minérale en conservant les bouchons existants. S'il y versera de l'huile synthétique, il devra substituer les bouchons existants avec d'autres bouchons de type fermé. Le réducteur de type 050 est fourni lubrifié à vie avec de l'huile synthétique. Voir tableau 1 concernant les huiles et les quantités conseillées. Voir tableau 2 concernant les charges radiales et axiales applicables au réducteur.

E El reductor tamaño 115 se suministra sin lubricante, provisto de tapones de respiración, nivel y descarga de aceite. El usuario puede utilizar aceite mineral, manteniendo los tapones existentes. Si prefiere utilizar aceite sintético deberá sustituir los tapones existentes por tapones ciegos. El reductor 050 se suministra lubricado de por vida con aceite sintético. Ver tabla 1, para cantidades y aceites recomendados. En la tabla 2, se encuentran las cargas radiales y axiales admitidas por el reductor.

B3	B6	B7	B8	V5	V6
2.0/0.14 LT	1.5/0.14 LT	1.5/0.14 LT	2.0/0.14 LT	2.0/0.14 LT	2.0/0.14 LT

AGIP Blasia 460

For all details on lubrication and plugs check our website [Per maggiori dettagli su lubrificazione e tappi olio vedi il nostro sito web](#) **tab. 1**

RADIAL AND AXIAL LOADS

Output shaft

Albero di uscita

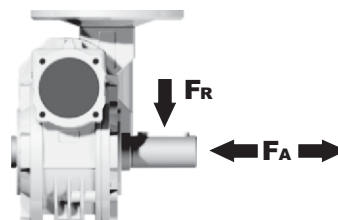

n_2 [min ⁻¹]	FA [N]	FR [N]
25	1200	6000
15	1400	7000

Input shaft

albero in entrata

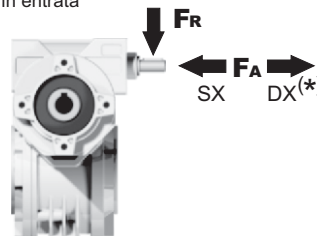

n_1 [min ⁻¹]	FA [N]	FR [N]
1400	76	380

*Strong axial loads in the DX direction are not allowed.
Non sono consentiti forti carichi assiali con direzione DX

tab. 2

3D dimensions on request

P115FB... Basic wormbox
Riduttore base

Gearbox weight
peso riduttore **38.00 kg**

M. flanges	Kit code	øF	A
63B5	K050.4.041	138	78.5
71B5	K050.4.042	160	76
80B5	K050.4.043	200	76.5
56B14	KC40.4.049	80	76
63B14	K050.4.047	90	78.5
71B14	K050.4.045	105	76
80B14	K050.4.046	120	76.5

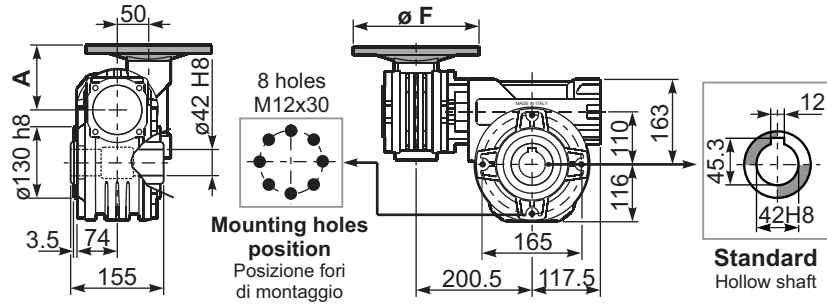

Standard
Hollow shaft

P115PA... Feet
Piedini

P115PB... Feet
Piedini

P115PV... Feet
Piedini

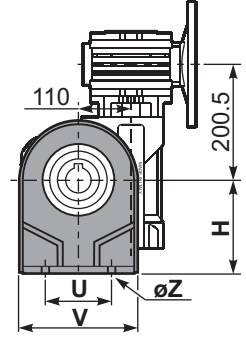
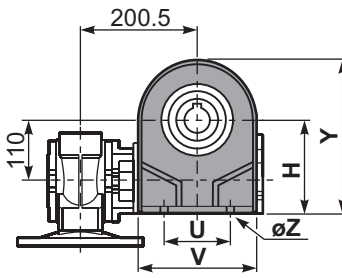
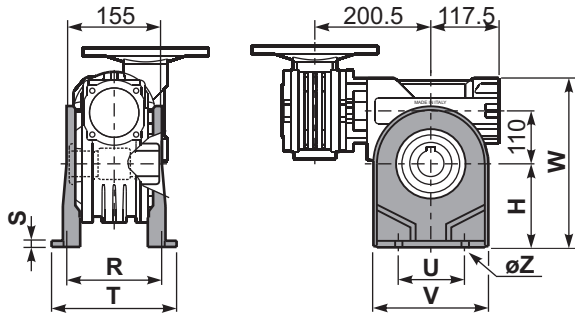

	H	R	S	T	U	V	Y	W	øZ	kit code
type B	170	180	22	224	200	240	286	333	ø13	K110.9.022
type S	172	160	18	190	200	240	288	335	ø14	KS110.9.023

P115FC... Output flange
Flangia uscita

P115BR... Reaction arm
Braccio di reazione

kit cod. K110.9.027

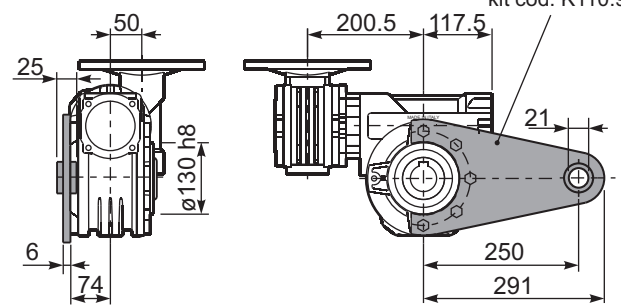
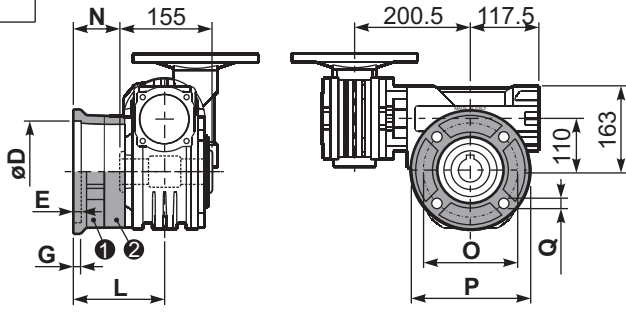

type B	øD	E	G	L	N	O	P	Q	kit code
FC	170 ^{+0.083} / _{+0.043}	11	16.5	131.5	54	230	270	13	1 2 K110.9.010
FL	170 ^{+0.083} / _{+0.043}	11	16.5	179.5	102	230	270	13	1 2 K110.9.011
type S	øD	E	G	L	N	O	P	Q	kit code
F1	180 ^{+0.040} / ₀	5	18	150	72.5	215	250	15	1 2 KS110.9.014
F2	170 ^{+0.083} / _{+0.043}	9.5	15	178	100.5	230	270	13	1 2 KS110.9.012
F3	180 ^{+0.040} / ₀	5	18	130	52.5	215	250	15	1 2 KS110.9.013

P115....S... Single Shaft
Albero lento semplice

P115....D... Double Shaft
Albero lento bisp.

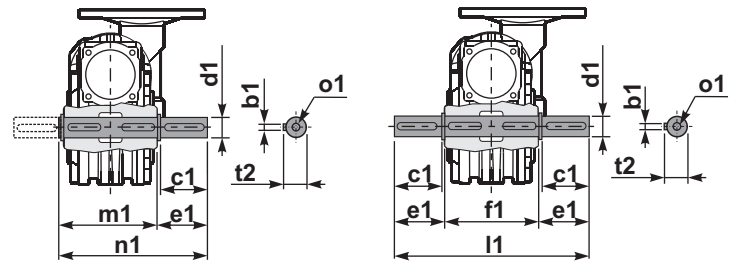

1 kit cod. K110.5.028 type B

2 kit cod. K110.5.029 type B

R115FB... Input shaft
Albero in entrata

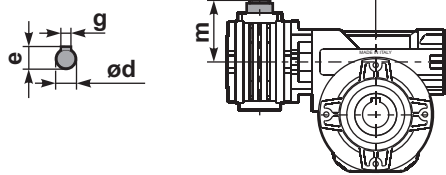

	ød	e	g	l	m	x	kit code
type B	16 h6	18	5	30	74.5	M6x16	1 K050.5.006 PAM71 2 K050.5.007 PAM80
type S	14 h6	16	5	30	74.5	M5x10	1 KS050.5.008 PAM71 2 KS050.5.009 PAM80

	b1	c1	d1	e1	f1	l1	m1	n1	t2	o1
type B	12	75	42 ^{-0.005} / _{-0.020}	96.5	155	348	163.5	260	45	M12x32
type S	-	-	-	-	-	-	-	-	-	-

Worm gearboxes type Q30 ÷ Q15

A modular and compact product

Single-piece aluminum alloy housing

Is vacuum impregnated (MIL-STD 276) for protection and sealing.

No secondary finish required but readily accepts paint. Combines light weight with high tensile strength. Precision machined for alignment of bearings and gearing.

Single piece alloy steel input shaft and worm shaft.

High helix angle worm is case-hardened (Rc 58-60), ground, teeth are profiled and radiused, for noise reduction and enhanced efficiency.

Oversized bearings

Support positively-retained, high speed shaft for higher shock load capacity - ideal for frequent starting and reversing application. Premium, Nitrile® high temperature seals each end.

Flange

Fully modular to IEC and compact integrated motor. NEMA C flange.

Premium, high temperature

Nitrile® output seals

Bronze alloy worm gears.

Is centrifugally cast onto an iron hub for maximum strength and superior life.

Over-size bearing

For radial load capability and maximum hollow output shaft diameter.

Standard hollow output shaft mounting

Reduces total drive envelope size, weight and cost. Single and double solid output shaft is available.

Impregnated and machined bearing caps

With exterior machined surfaces enable a variety of mounting accessories. Extra-deep thread engagement provided for greater support strength. Zinc plated hardware.

Vent Free Design.

No breather or vents to leak! Factory lubricated for life with synthetic, semi-fluid gear lubricant with an operating range of -15°C to 130°C.

oil free



vent free



World wide sales network.

Specific type datasheet on page...

On page / A pagina / Auf Seite / À la page / En la página

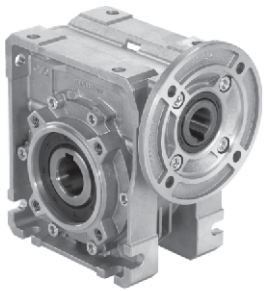

Types / Tipi /
Tipen / Types /
Tipos →

2-5	2-7	2-9	2-11	2-13	2-15	2-17	2-19	2-21
Q30 21Nm	Q45 41Nm	Q50 72Nm	Q63 147Nm	Q75 270Nm	Q85 347Nm	Q11 651Nm	Q13 1050Nm	Q15 1550Nm

On page / A pagina / Auf Seite / À la page / En la página

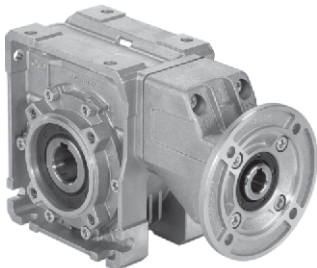

Types / Tipi /
Tipen / Types /
Tipos →

2-23	2-25	2-27	2-29	2-31	2-33
P4Q 55Nm	P5Q 88Nm	P6Q 187Nm	P7Q 310Nm	P8Q 440Nm	P1Q 803Nm

On page / A pagina / Auf Seite / À la page / En la página

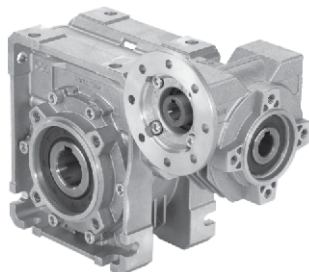

Types / Tipi /
Tipen / Types /
Tipos →

2-35	2-37	2-39	2-41	2-43	2-45	2-47
43Q 69Nm	53Q 109Nm	63Q 230Nm	64Q 265Nm	74Q 359Nm	84Q 518Nm	15Q 978Nm

Type - Tipo - Typ
Type - Tipo

Size - Grandezza
Größe - Taille
Tamaño

Mounting - Montaggio - Montage Fixation
Fixation - Tipo de montaje

P

Q45

FC

Worm gearboxes

Riduttori a vite senza fine
Schneckengetriebe
Reducteurs a vis sans fin
Reductores de corona sin fin

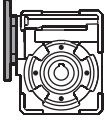

P

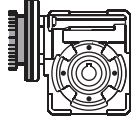

M



B

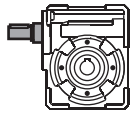

R

Q30
Q45
Q50
Q63
Q75
Q85
Q11
Q13
Q15

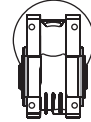

FB

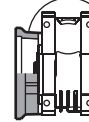

FC

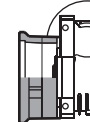

FL

F1
F2
F3
F4

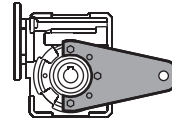

BR

Worm gearboxes with primary reduction

Riduttori a vite senza fine con precoppia
Schneckengetriebe mit Stirradstufe am Eintrieb
Reducteurs a vis sans fin avec pré-réduction
Reductores corona sin fin con prerreductora de engranajes

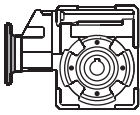

P

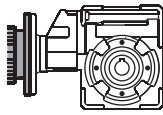

M

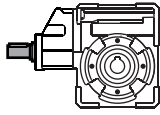

R

P4Q
P5Q
P6Q
P7Q
P8Q
P1Q



FB

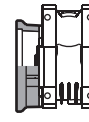

FC

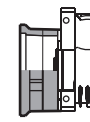

FL

F1
F2
F3
F4

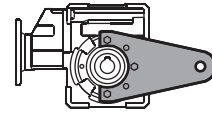

BR

Combined worm gearboxes

Riduttori a vite senza fine combinati
Schneckengetriebekombinationen
Reducteurs a double train de vis sans fin
Reductores combinados corona sin fin

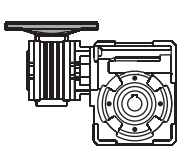

P

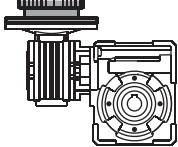

M

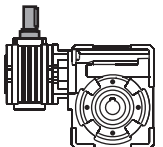

R

43Q
53Q
63Q
64Q
74Q
84Q
15Q

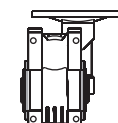

FB

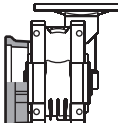

FC

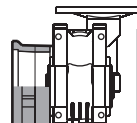

FL

F1
F2
F3
F4

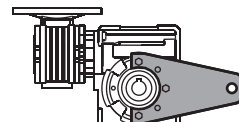



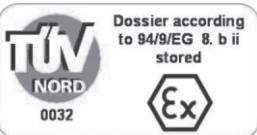



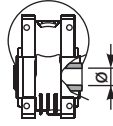
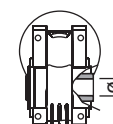
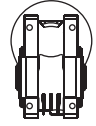
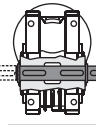
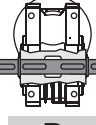
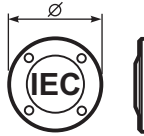

BR

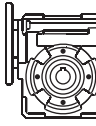

On request we can deliver our products according to the ATEX
A richiesta possiamo fornire i nostri prodotti secondo le normative ATEX
Auf Anfrage können wir unsere Produkte den Richtlinien ATEX entsprechend liefern
Sur demande nos produits peuvent se conformer à la réglementation ATEX
A pedido, se pueden enviar nuestros productos de acuerdo con las normas ATEX.

CODIFICA / HOW TO ORDER / TYPENBEZEICHNUNGEN / CODIFICATION / CODIFICACIÓN

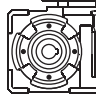
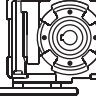
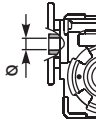
Ratio Rapporto Untersetzung Reduction Relación	Hub Mozzo corona Hohlwelle Arbre creux Nucleo corona	Output shaft Albero lento Abtriebswelle Arbre de sortie Eje solida	Motor size Grandezza motore Motor Grösse Grandeur moteur Tamaño motor	Terminal box position Posizione morsetiera Klemmkastenlage Position boîte a bornes Posición caja de bornes	Mounting position Posizione montaggio Einbaulage Position de montage Position de montaje	Reduced Input bore Foro entrata ridotto Reduzierte Eingangshohlwelle Trou d'entree de diametre reduit Eje hueco de entrada reducido	Mountin position Esecuzione montaggio Einbaulage Exécution de montage Posición de montaje
10	C	∅	-Q	B	B3	-	---
See technical data table Vedi tabella dati tecnici. Technisches Datenblatt beachten Voir tableau données techniques Ver tabla datos técnicos	 C STANDARD Q30 ⇨ ∅14 Q45 ⇨ ∅18 Q50 ⇨ ∅25 Q63 ⇨ ∅25 Q75 ⇨ ∅30 Q85 ⇨ ∅35 Q11 ⇨ ∅42 Q13 ⇨ ∅45 Q15 ⇨ ∅50 I Stainless steel hub Mozzo in acciaio Inox Edelstahlhohlwelle Moyeu en acier Inox Nucleo corona de acero Inox Special series Serie Speciale S Q45 ⇨ ∅19 Q50 ⇨ ∅24 X Stainless steel hub Mozzo in acciaio Inox Edelstahlhohlwelle Moyeu en acier Inox Nucleo corona de acero Inox  U INCH Q45 ⇨ ∅0.750" Q50 ⇨ ∅1.000" Q63 ⇨ ∅1.125" Q85 ⇨ ∅1.500"	 ∅  S  D	 -M without flange Senza flangia B5 -A =56 (∅120) -B =63 (∅140) -C =71 (∅160) -D =80 (∅200) -E =90 (∅200) -F =100+112 (∅250) -G =132 (∅300) -H =160 (∅350) B14 -O =56 (∅80) -P =63 (∅90) -Q =71 (∅105) -R =80 (∅120) -T =90 (∅140) -U =100+112 (∅160) -V =132 (∅200) -0 =Type R -S =Type R S series Reduced Fl. -1 =56B5/∅11 -2 =63B5/∅14 -3 =71B5/∅19 -4 =71B5/∅24 -5 =90B5/∅28 -6 =100B5/∅38 -7 =132B5/∅42 -8 =80B14/∅11 -9 =100B5/∅24	 A  B STANDARD  C  D	 B3  B8  B6  B7  V5  V6	 - Nothing indication standard bore Nessuna indicazione standard P Input bore reduced one size Foro entrata ridotto di una misura Ex. Input Flange 71 B14 Standard ∅14 Reduced ∅11 Q Input bore reduced two sizes Due grandezze ridotte foro entrata Ex. Input Flange 71 B14 Standard ∅14 Reduced ∅9	Only for combined units See technical data table Solo per i riduttori combinati Vedi tabella dati tecnici. Ausführungen für Getriebekombinationen it Uniquement pour combinés. Voir tableau données techniques Sólo para combinados ver tabla datos técnicos

POTENZA RICHIESTA / REQUIRED POWER / ERFORDERLICHE LEISTUNG / PUISSANCE NECESSAIRE / POTENCIA NECESARIA

Lifting / sollevamento / hubantriebe / levage / elevación

$$P \text{ [KW]} = \frac{M \text{ [Kg]} \cdot g \text{ [9.81]} \cdot v \text{ [m / s]}}{1000}$$

Rotation / rotazione / drehung / rotation / rotação

$$P \text{ [KW]} = \frac{M \text{ [Nm]} \cdot n \text{ [rpm]}}{9550}$$

Linear movement / traslazione / linearbewegung / translation / translación

$$P \text{ [KW]} = \frac{F \text{ [N]} \cdot v \text{ [m / s]}}{1000}$$

TORQUE / COPPIA / DREHMOMENT / COUPLE / PAR

$$M \text{ [Nm]} = \frac{9550 \cdot P \text{ [KW]}}{n \text{ [rpm]}}$$

$$M \text{ [lb in]} = \frac{63030 \cdot P \text{ [HP]}}{n \text{ [rpm]}}$$

RADIAL LOADS / CARICHI RADIALI / RADIALE - UND AXIALLASTEN / CHARGES RADIALES / CARGA RADIAL Y AXIAL

- Radial load generated by external transmissions keyed onto input and/or output shafts.
- Forza radiale generata da organi di trasmissione calettati sugli alberi di ingresso e/o uscita.
- Belastungen der Antriebs- bzw. Abtriebswellen durch von aussen eingebrachte Radiallasten.
- Charge radiale générée par la transmissions calés sur les entrées et / ou des arbres de sortie
- Cargas radiales, generada por transmisiones externas, aplicadas sobre los ejes de entrada y/o salida

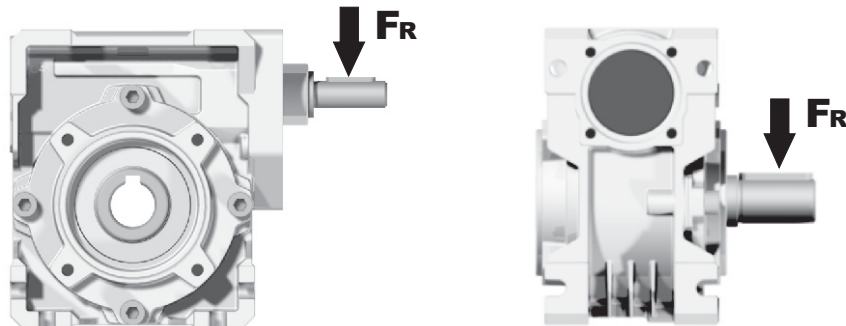

	$F_R \text{ [N]} = \frac{M \text{ [Nm]} \cdot 2000}{d \text{ [mm]}} \cdot f_k$	$F_R \text{ [N]} = \frac{M \text{ [lb in]} \cdot 8.9}{d \text{ [in]}} \cdot f_k$
M	Momento torcente / Output torque / Abtriebsdrehmoment / Couple / Par torsion	
d	Diametro primitivo / Diam. of driving element / Durchmesser der Abtriebseinheit / Diamètre primitif / Diámetro primitivo	
f_k	Coefficiente di trasformazione / Factor / Faktor / Coefficient de transmission / Coeficiente de transmisión 1.15 Ingranaggi / Gearwheels / Zahnrad / Engrenage / Engranaje 1.25 Catena / Chain sprockets / Antriebskette / Chaîne / Cadena 1.75 Cinghia Trapezoidale / Narrow v-belt pulley / Keilriemen / Courroie trap. / Correa trapezoidal 2.50 Cinghia piatta / Flat-belt pulley / Flachzahnriem. / Courroie crantée / Correa plana	

- If your application requires higher radial loads, contact our technical office. Higher load may be possible.
- Nel caso la vostra applicazione richieda carichi radiali superiori consultare il nostro ufficio tecnico, valori maggiori possono essere accettati.
- Wenn Ihre Anwendung höhere Radialbelastungen erfordert, so wenden Sie sich bitte an unser technischen Büro.
- Si votre application demande des charges radiales supérieures, s'adresser à notre bureau technique.
- En el caso en que una aplicación exija una carga radial superior a la especificada en el catálogo, consultar a nuestra oficinas técnica.

How to select a gearbox / Come selezionare un riduttore / Wie wählt man ein Getriebe
Comment sélectionner un réducteur / Cómo seleccionar un reductor

B Output speed
Velocità in uscita
Abtriebsdrehzahl
Vitesse de sortie
Velocidad de salida

Nominal power
Potenza nominale
Max. mögliche Leistung
Poissance nominale
Potencia nominal

Gear size
Grandezza riduttore
Getriebegröße
Taille réducteur
Tamaño reductor

Motor power
Potenza motore
Motorleistung
Puissance moteur
Potencia motor

A Nominal torque
Momento torcente nominale
Nenn Drehmoment
Couple nominal
Par de torsión nominal

Flange code
Codice flangia
Flanschtype
Code bride
Código bridas

Dynamic efficiency
Rendimento dinamico
Dynamischer
Rendement dynamique
Rendimento dinámico

Input speed
Velocità in entrata
Eintriebsdrehzahl
Vitesse en entrée
Velocidad de entrada

Q45

Square - Gear
41Nm

Rating - Aluminum WORM GEARBOXES

QUICK SELECTION / Selezione veloce							input speed (n ₁) = 1400 min ⁻¹							
Output Speed n ₂ [min ⁻¹]	Ratio i	Motor power P _{1M} [kW]	Output torque M _{2M} [Nm]	Service factor f.s.	Nominal power P _{1R} [kW]	Nominal torque M _{2R} [Nm]	Available B5 motor flanges		Available B14 motor flanges			Dynamic efficiency RD	Tooth Module [mm]	Ratios code
							B	C	O	P	Q			
200	7	0.37	14	2.2	0.80	30	B		B-C	B-C		80	2.2	01
140	10	0.37	20	1.5	0.57	30	B		B-C	B-C		79	2.2	02
100	14	0.37	27	1.1	0.41	30	B		B-C	B-C		77	2.4	03

C Ratio
Rapporto
Untersetzung
Rapport de réduction
Relación

Transmitted torque
Momento torcente trasmesso
Mögliche Drehmomente
Couple de sortie
Par transmitido

Service factor
Fattore di servizio
Betriebsfaktor
Facteur de service
Factor de servicio

Nominal module
Modulo nominale
Nenn modul
Module nominale
Módulo nominal

Notes
Note
Anmerkungen
Note
Notas

Type of load and starts per hour Tipo di carico e avviamenti per ora		Oper. hours per day Ore di funz. giorn.		
		<2 h	2 - 8 h	8 - 16 h
Continuous or intermittent appl. with start / hour Applicazione cont. o interm. con n.ro operazioni/ora	Uniform / Uniforme	0.9	1	1.25
	Moderate / Moderato	1	1.25	1.5
	Heavy / Forte	1.25	1.5	1.75
Intermittent application with start / hour Applicazione intermittente con n.ro operazioni/ora	Uniform / Uniforme	1.25	1.5	1.75
	Moderate / Moderato	1.5	1.75	2
	Heavy / Forte	1.75	2	2.25

D Motor flange available Flange disponibili Erhältliche Motorflansche Brides disponibles Bridas disponibles	
B)	Mounting with reduction ring Montaggio con boccolla di riduzione Reduzierhülsen Montage avec douille de réduction Montaje con casquillo de reducción
C)	Motor flangeholes position/terminal box position Posizione fori flangia/basetta motore Bohrungsposition am Motorflansch/-sockel Position trous bride/barrette à bornes moteur Posición agujeros brida / base motor
B)	Available without reduction bushes Disponibile anche senza boccolla Auch ohne Reduzierbuchse verfügbar Disponible aussi sans douille de réduction Disponible tambien sin casquillo

A	Select required torque (according to service factor)	Seleziona la coppia desiderata (comprensiva del fattore di servizio)	Max. Drehmoment in Bezug zum Betriebsfaktor	Sélectionner le couple souhaité (comprenant le facteur de service)	Seleccionar el par deseado (incluyendo el factor de servicio)
B	Select output speed	Seleziona la velocità in uscita	Ausgewählte Abtriebsdrehzahl	Sélectionner la vitesse de sortie	Seleccionar la velocidad de salida
C	On the same line of selected geared motor, you can find the gear ratio	Sulla riga corrispondente alla motorizzazione prescelta si può rilevare il rapporto di riduzione	Auf der gleichen Linie wie die ausgewählte Motorleistung steht auch die Getriebeuntersetzung	Sur la ligne correspondante à la motorisation pré-choisie on peut relever le rapport de réduction	En la línea correspondiente al motor preseleccionado es posible encontrar la relación de reducción
D	Select motor flange available (if requested)	Scegli la flangia disponibile (se richiesta)	Erhältliche Motorflansche (auf Anfrage)	Choisir la bride disponible (si elle est demandée)	Seleccionar la brida disponible (sobre pedido)



QUICK SELECTION / Selezione veloce

input speed (n_1) = 1400 min⁻¹

Output Speed n_2 [min ⁻¹]	Ratio i	Motor power P_{1M} [kW]	Output torque M_{2M} [Nm]	Service factor f.s.	Nominal power P_{1R} [kW]	Nominal torque M_{2R} [Nm]	Available B5 motor flanges		Available B14 motor flanges		Dynamic efficiency RD	Tooth Module [mm]	 Ratios code
							A	B	O	P			
							56	63	56	63			
280	5	0.18	5	3.3	0.60	17	B		B-C		82	1.26	01
200	7	0.18	7	2.4	0.44	17	B		B-C		80	1.44	02
140	10	0.18	10	1.8	0.32	17	B		B-C		78	1.44	03
93	15	0.18	13	1.4	0.25	19	B		B-C		73	1.44	04
70	20	0.18	17	1.1	0.20	19	B		B-C		70	1.09	05
47	30	0.12	15	1.4	0.17	21	B		B-C		62	1.44	06
35	40	0.12	19	1.1	0.13	20	B		B-C		57	1.09	07
23	61	0.09	19	1.1	0.10	20	B		B-C		50	0.72	08
17.5	80	0.09	16	1.0	0.06	16	B		B-C		48	0.56	09

A) Motor Flanges Available
Flange Motore Disponibili

B) Supplied with Reduction Bushing
Fornito con Bussola di Riduzione

B) Available on Request without reduction bushing
Disponibile a Richiesta senza Bussola di Riduzione

C) Motor Flange Holes Position
Posizione Fori Flangia Motore

EN Unit **Q30** is supplied with synthetic oil, providing "long life" lubrication. For mounting position V5-V6 please contact us.
See table 1 for lubrication and recommended quantity.
In table 2 please see possible radial loads and axial loads on the gearbox.

I Il riduttore tipo **Q30** viene fornito lubrificato a vita con olio sintetico. Per posizioni V5-V6 contattare il ns. servizio tecnico.
Vedi tab.1 per oli e quantità consigliati.
In tab.2 sono presenti i carichi radiali e assiali applicabili al riduttore.

D Für die Lebensdauerschmierung ist das Getriebe der Größe **Q30** mit synthetischem Öl befüllt.
Bei Einbaulage V5 oder V6 bitten wir um Rücksprache.
In Tabelle 1 ist die Schmiermenge und das empfohlene Schmiermittel angegeben.
In Tabelle 2 sind die zulässigen Radial- und Axialbelastungen des Getriebes aufgeführt.

F Le réducteur de type **Q30** est fourni lubrifié à vie avec de l'huile synthétique. Concernant les positions V5.V6, contactez notre service d'assistance technique.
Voir tableau 1 concernant les huiles et les quantités conseillées.
Les charges radiales et axiales applicables au réducteur sont précisées dans le tableau 2.

E El reductor tamaño **Q30** se suministra, lubricado de por vida con aceite sintético. Para las posiciones V5 y V6 contactar con nuestro servicio técnico.
Ver tabla 1, para cantidades y aceites recomendados.
En la tabla 2, se encuentran las cargas radiales y axiales admitidas por el reductor.

LUBRICATION Q30 Oil Quantity 0.03Lt.

AGIP Telium VSF 320

SHELL Omala S4 WE 320

For all details on lubrication and plugs check our website **tab. 1**
Per maggiori dettagli su lubrificazione e tappi olio vedi il nostro sito web

RADIAL AND AXIAL LOADS

Output shaft

Albero di uscita

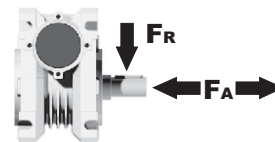

n_2 [min ⁻¹]	FA [N]	FR [N]
200	120	600
150	140	700
100	160	800
75	180	900
50	200	1000
25	250	1250
15	280	1400

Input shaft

albero in entrata

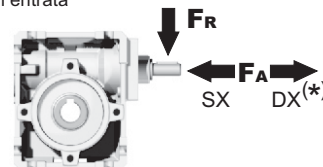

n_1 [min ⁻¹]	FA [N]	FR [N]
1400	20	100

***Strong axial loads in the DX direction are not allowed.**
Non sono consentiti forti carichi assiali con direzione DX

tab. 2

PQ30FB... Basic wormbox
Riduttore base

Gearbox weight
peso riduttore **1.15 kg**

M. flanges	Kit code	øF	A
56B5	K030.4.041	120	61.5
63B5	K030.4.042	140	62.5
56B14	K030.4.046	80	61.5
63B14	K030.4.045	90	62.5

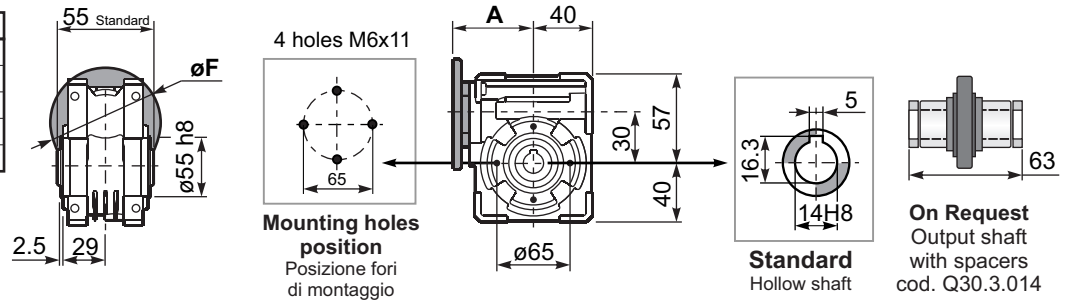

PQ30FC... Square flange
Flangia quadrata

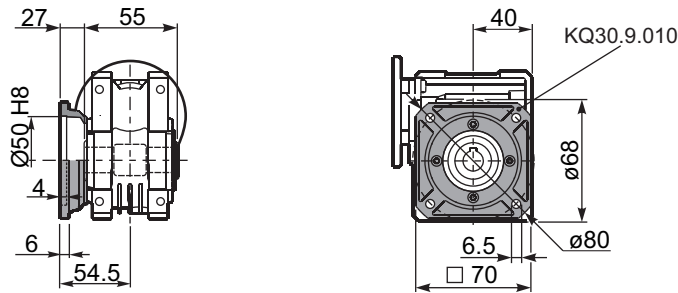

PQ30FB... Feet
Piedini

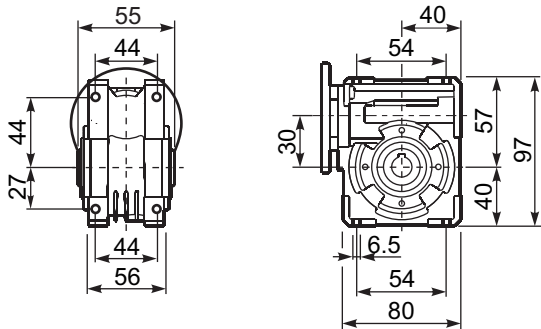

PQ30BR... Reaction arm
Braccio di reazione

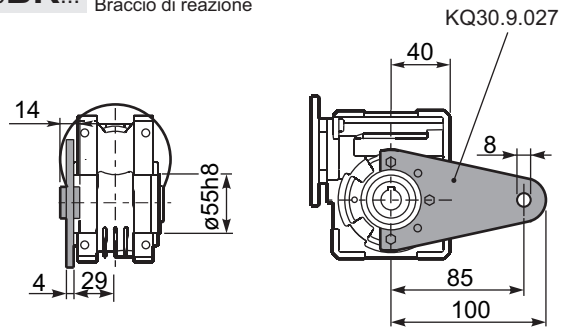

RQ30FB... Input shaft
Albero in entrata

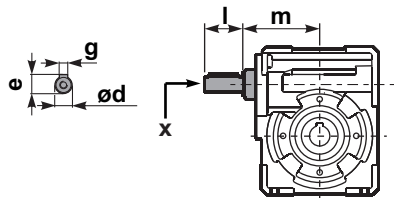

PQ30.....S... Single Shaft
Albero lento semplice

PQ30.....D... Double Shaft
Albero lento bisp.

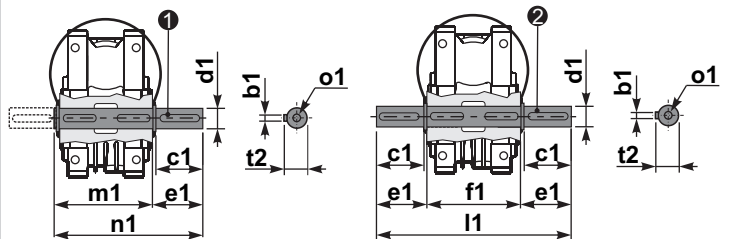

① kit cod. K030.5.028 type B

② kit cod. K030.5.029 type B

	ød	e	g	l	m	x	kit code
type B	9 h6	10.2	3	20	58	-	K030.5.006 PAM63
type S	-	-	-	-	-	-	-

	b1	c1	d1	e1	f1	l1	m1	n1	t2	o1
type B	5	25	14 ^{-0.005} _{-0.020}	35.5	55	126	59	94.5	16	M5x14
type S	-	-	-	-	-	-	-	-	-	-



QUICK SELECTION / Selezione veloce

input speed (n_1) = 1400 min⁻¹

Output Speed n_2 [min ⁻¹]	Ratio i	Motor power P_{1M} [kW]	Output torque M_{2M} [Nm]	Service factor f.s.	Nominal power P_{1R} [kW]	Nominal torque M_{2R} [Nm]	Available B5 motor flanges		Available B14 motor flanges			Dynamic efficiency RD	Tooth Module [mm]	Ratios code
							B	C	O	P	Q			
							63	71	56	63	71			
200	7	0.37	14	2.2	0.80	30	B		B-C	B-C		80	2.2	01
140	10	0.37	20	1.5	0.57	30	B		B-C	B-C		79	2.2	02
100	14	0.37	27	1.1	0.41	30	B		B-C	B-C		77	2.4	03
67	21	0.37	36	1.2	0.43	41	B		B-C	B-C		67	1.6	04
50	28	0.25	31	1.3	0.33	41	B		B-C	B-C		65	2.5	05
38	37	0.25	40	1.0	0.26	41	B		B-C	B-C		63	1.8	06
30	46	0.25	46	0.9	0.22	41	B		B-C	B-C		59	1.5	07
23	60	0.18	41	1.0	0.18	41	B		B-C	B-C		56	1.2	08
20	70	0.12	31	1.0	0.12	30	B		B-C	B-C		54	1.0	09
13.7	102	0.09	31	1.0	0.09	29	B		B-C	B-C		49	0.72	10

A Motor Flanges Available
Flange Motore Disponibili

B Supplied with Reduction Bushing
Fornito con Bussola di Riduzione

B Available on Request without reduction bushing
Disponibile a Richiesta senza Bussola di Riduzione



C Motor Flange Holes Position
Posizione Fori Flangia Motore

* Power higher than the maximum one which can be supported by the gearbox. Select according to the torque M_{2R}
Potenza superiore a quella massima sopportabile dal riduttore. Selezionare in base al momento torcente M_{2R}

EN Unit Q45 is supplied with synthetic oil, providing "long life" lubrication. For mounting position V5-V6 please contact us. See table 1 for lubrication and recommended quantity. In table 2 please see possible radial loads and axial loads on the gearbox.

I Il riduttore tipo Q45 viene fornito lubrificato a vita con olio sintetico. Per posizioni V5-V6 contattare il ns. servizio tecnico. Vedi tab.1 per oli e quantità consigliati. In tab.2 sono presenti i carichi radiali e assiali applicabili al riduttore.

D Für die Lebensdauerschmierung ist das Getriebe der Größe Q45 mit synthetischem Öl befüllt. Bei Einbaulage V5 oder V6 bitten wir um Rücksprache. In Tabelle 1 ist die Schmiermenge und das empfohlene Schmiermittel angegeben. In Tabelle 2 sind die zulässigen Radial- und Axialbelastungen des Getriebes aufgeführt.

F Le réducteur de type Q45 est fourni lubrifié à vie avec de l'huile synthétique. Concernant les positions V5.V6, contactez notre service d'assistance technique. Voir tableau 1 concernant les huiles et les quantités conseillées. Les charges radiales et axiales applicables au réducteur sont précisées dans le tableau 2.

E El reductor tamaño Q45 se suministra, lubricado de por vida con aceite sintético. Para las posiciones V5 y V6 contactar con nuestro servicio técnico. Ver tabla 1, para cantidades y aceites recomendados. En la tabla 2, se encuentran las cargas radiales y axiales admitidas por el reductor.

LUBRICATION Q45 Oil Quantity 0.09 Lt.

AGIP Telium VSF 320

SHELL Omala S4 WE 320

For all details on lubrication and plugs check our website **tab. 1**
Per maggiori dettagli su lubrificazione e tappi olio vedi il nostro sito web

RADIAL AND AXIAL LOADS

Output shaft
Albero di uscita

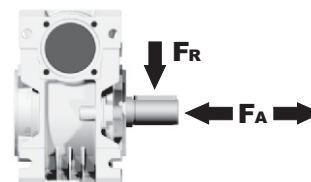

n_2 [min ⁻¹]	FA [N]	FR [N]
200	180	900
150	200	1000
100	220	1100
75	240	1200
50	260	1400
25	300	1800
15	400	2000

Input shaft
albero in entrata

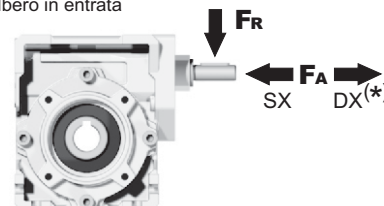

n_1 [min ⁻¹]	FA [N]	FR [N]
1400	42	210

*Strong axial loads in the DX direction are not allowed.
Non sono consentiti forti carichi assiali con direzione DX

tab. 2

PQ45FB... Basic wormbox
Riduttore base

M. flanges	Kit code	øF	A
63B5	K050.4.041	138	80
71B5	K050.4.042	160	77.5
56B14	KC40.4.049	80	77.5
63B14	K050.4.047	90	80
71B14	K050.4.045	105	77.5

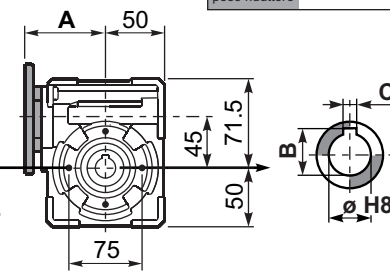
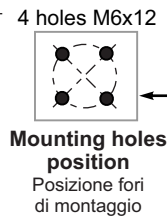
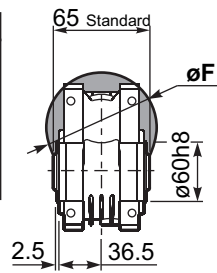

Gearbox weight
peso riduttore **2.30 kg**

ø H8	B	C	*Spacer code
18 Standard	20.8	6	Q45.3.018
19 on request	21.8	6	Q45.3.019
20 on request	22.8	6	Q45.3.020

*On Request
output shaft with spacers

PQ45FC... Square flange
Flangia quadrata

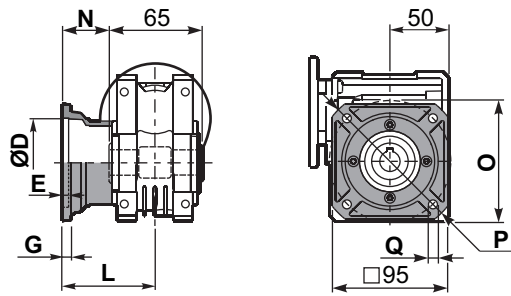

type B	øD	E	G	L	N	O	P	Q	kit code
FC	60 H8	4	7	67	34.5	75	110	9	KQ45.9.010
FL	60 H8	4	7	97	64.5	75	110	9	KQ45.9.011

PQ45F1... Round flange
Flangia rotonda

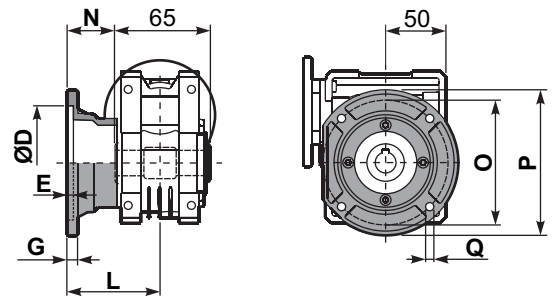

type S	øD	E	G	L	N	O	P	Q	kit code
F1	95H8	5	9	80	47.5	115	140	9.5	KSQ45.9.012
F2	80H8	5	12	58	25.5	100	120	9	KSQ45.9.013

PQ45FB... Feet
Piedini

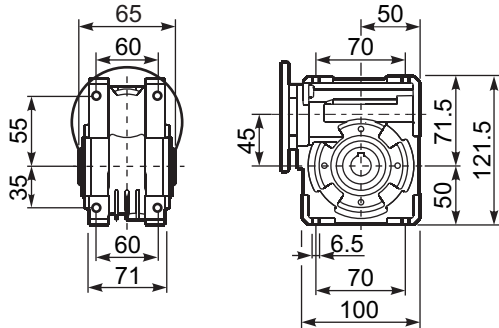

PQ45BR... Reaction arm
Braccio di reazione

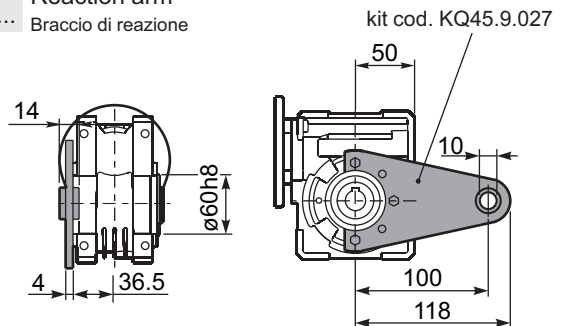

RQ45FB... Input shaft
Albero in entrata

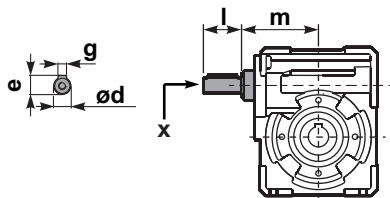

	ød	e	g	l	m	x	kit code
type B	11 h6	12.5	4	30	74	-	① K045.5.006 PAM71 ② - ③ -
type S	-	-	-	-	-	-	① - ② - ③ -

PQ45.....S... Single Shaft
Albero lento semplice

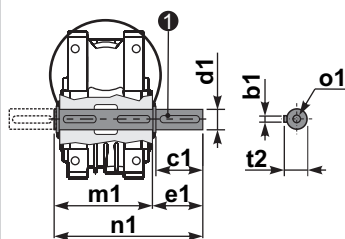

① kit cod. K045.5.028 type B
kit cod. KS045.5.030 type S

PQ45.....D... Double Shaft
Albero lento bisp.

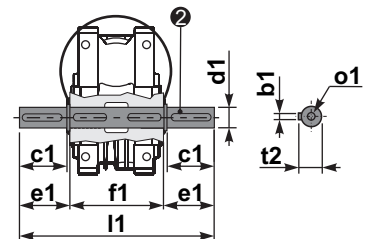

② kit cod. K045.5.029 type B
kit cod. KS045.5.031 type S

	b1	c1	d1	e1	f1	l1	m1	n1	t2	o1
type B	6	32	18 ^{-0.005} _{-0.020}	43	65	151	70	113	20.5	M6x18
type S	6	40	19 ^{-0.005} _{-0.020}	58.5	65	182	70	128.5	21.5	M8x20



QUICK SELECTION / Selezione veloce

input speed (n_1) = 1400 min⁻¹

Output Speed n_2 [min ⁻¹]	Ratio i	Motor power P_{1M} [kW]	Output torque M_{2M} [Nm]	Service factor f.s.	Nominal power P_{1R} [kW]	Nominal torque M_{2R} [Nm]	Available B5 motor flanges			Available B14 motor flanges				Dynamic efficiency RD	Tooth Module [mm]	Ratios code
							B	C	D	O	P	Q	R			
							63	71	80	56	63	71	80			
200	7	0.75	29	1.9	1.5	57	B	B			B-C	B		82	2.5	01
140	10	0.75	41	1.5	1.1	62	B	B			B-C	B		80	2.4	02
100	14	0.75	57	1.2	0.90	68	B	B			B-C	B		79	2.6	03
78	18	0.55	51	1.2	0.67	62	B	B			B-C	B		75	2.0	04
54	26	0.55	67	1.0	0.54	66	B	B			B-C	B		69	2.7	05
47	30	0.55	79	0.9	0.50	72	B	B			B-C	B		70	2.5	12
39	36	0.37	63	1.2	0.43	72	B			B-C	B-C			69	2.1	06
33	43	0.37	72	1.0	0.35	68	B			B-C	B-C			66	1.8	07
23	60	0.25	59	1.0	0.26	62	B			B-C	B-C			58	1.3	08
21	68	0.25	66	0.9	0.22	58	B			B-C	B-C			57	1.2	09
17.5	80	0.18	53	1.1	0.19	57	B			B-C	B-C			54	1.0	10
14	100	0.12	41	1.3	0.15	51	B			B-C	B-C			50	0.8	11

A) Motor Flanges Available
Flange Motore Disponibili

B) Supplied with Reduction Bushing
Fornito con Bussola di Riduzione

B) Available on Request without reduction bushing
Disponibile a Richiesta senza Bussola di Riduzione

C) Motor Flange Holes Position
Posizione Fori Flangia Motore

EN Unit **Q50** is supplied with synthetic oil, providing "long life" lubrication. For mounting position V5-V6 please contact us. See table 1 for lubrication and recommended quantity. In table 2 please see possible radial loads and axial loads on the gearbox.

I Il riduttore tipo **Q50** viene fornito lubrificato a vita con olio sintetico. Per posizioni V5-V6 contattare il ns. servizio tecnico. Vedi tab.1 per oli e quantità consigliati. In tab.2 sono presenti i carichi radiali e assiali applicabili al riduttore.

D Für die Lebensdauerschmierung ist das Getriebe der Größe **Q50** mit synthetischem Öl befüllt. Bei Einbaulage V5 oder V6 bitten wir um Rücksprache. In Tabelle 1 ist die Schmiermenge und das empfohlene Schmiermittel angegeben. In Tabelle 2 sind die zulässigen Radial - und Axialbelastungen des Getriebes aufgeführt.

F Le réducteur de type **Q50** est fourni lubrifié à vie avec de l'huile synthétique. Concernant les positions V5.V6, contactez notre service d'assistance technique. Voir tableau 1 concernant les huiles et les quantités conseillées. Les charges radiales et axiales applicables au réducteur sont précisées dans le tableau 2.

E El reductor tamaño **Q50** se suministra, lubricado de por vida con aceite sintético. Para las posiciones V5 y V6 contactar con nuestro servicio técnico. Ver tabla 1, para cantidades y aceites recomendados. En la tabla 2, se encuentran las cargas radiales y axiales admitidas por el reductor.

LUBRICATION Q50 Oil Quantity 0.14 Lt.

AGIP Telium VSF 320

SHELL Omala S4 WE 320

For all details on lubrication and plugs check our website **tab. 1**
Per maggiori dettagli su lubrificazione e tappi olio vedi il nostro sito web

RADIAL AND AXIAL LOADS

Output shaft

Albero di uscita

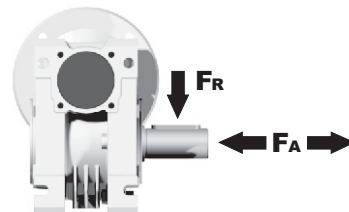

n_2 [min ⁻¹]	FA [N]	FR [N]
200	240	1200
150	280	1400
100	300	1500
75	340	1700
50	380	1900
25	480	2500
15	560	2800

Input shaft

albero in entrata

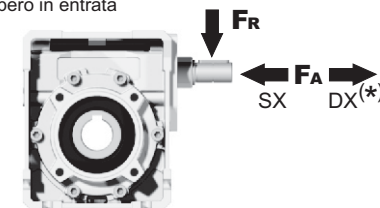

n_1 [min ⁻¹]	FA [N]	FR [N]
1400	76	380

***Strong axial loads in the DX direction are not allowed.**
Non sono consentiti forti carichi assiali con direzione DX

tab. 2

PQ50FB... Basic wormbox
Riduttore base

Gearbox weight
peso riduttore **3.25 kg**

ø H8	B	C	*Spacer code
25 Standard	28.3	8	Q50.3.025
24 on request	27.3	8	Q50.3.024

M. flanges	Kit code	øF	A
63B5	K050.4.041	138	83.5
71B5	K050.4.042	160	81
80B5	K050.4.043	200	81.5
56B14	KC40.4.049	80	81
63B14	K050.4.047	90	83.5
71B14	K050.4.045	105	81
80B14	K050.4.046	120	81.5

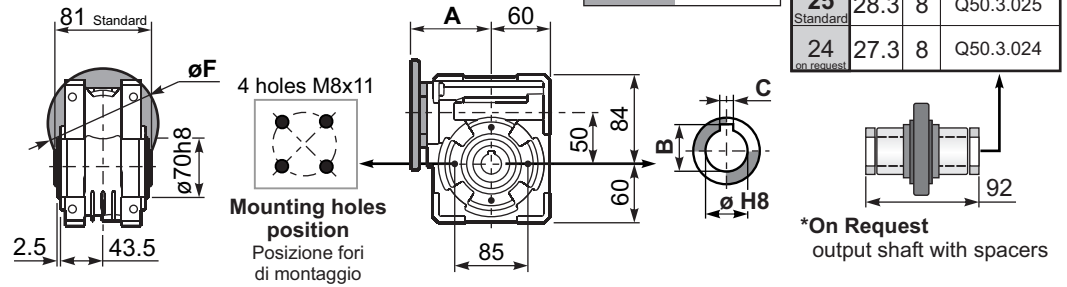

PQ50FC... Square flange
Flangia quadrata

PQ50F1... Round flange
Flangia rotonda

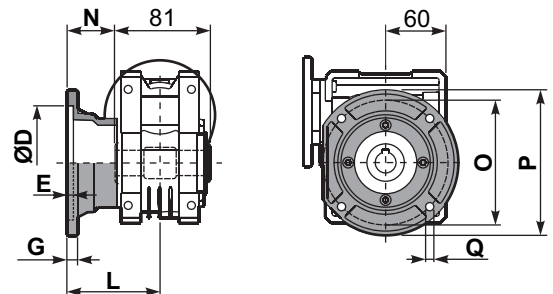
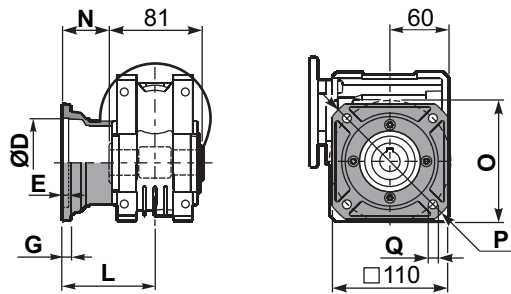

type B	øD	E	G	L	N	O	P	Q	kit code
FC	70 H8	5	9	90	49.5	85	125	11	KQ50.9.010
FL	70 H8	5	9	120	79.5	85	125	11	KQ50.9.011

type S	øD	E	G	L	N	O	P	Q	kit code
F1	110 H8	5	10	89	48.5	130	160	9.5	KSQ50.9.012
F2	95 H8	5	14.5	72	31.5	115	140	11	KSQ50.9.013

PQ50FB... Feet
Piedini

PQ50BR... Reaction arm
Braccio di reazione

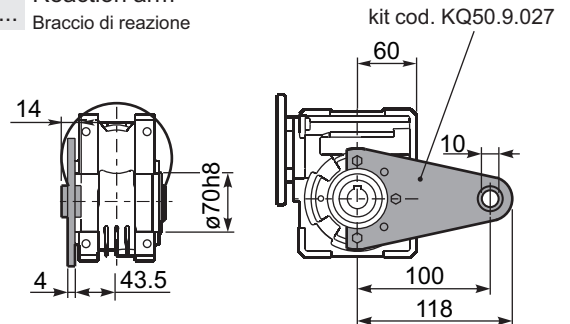
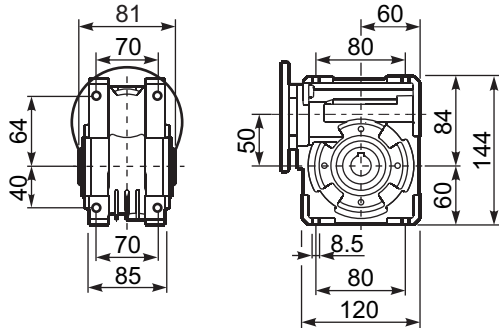

RQ50FB... Input shaft
Albero in entrata

PQ50.....S... Single Shaft
Albero lento semplice

PQ50.....D... Double Shaft
Albero lento bisp.

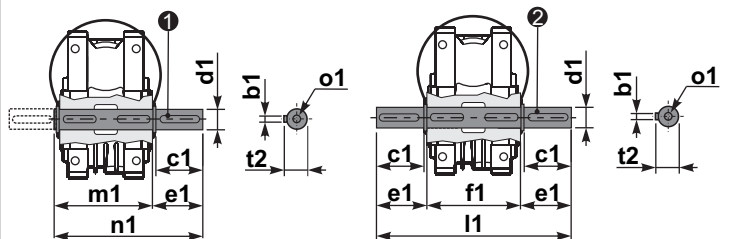
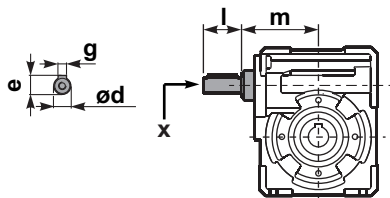

① kit cod. K050.5.028 type B
kit cod. KS050.5.030 type S

② kit cod. K050.5.029 type B
kit cod. KS050.5.031 type S

	ød	e	g	l	m	x	kit code
type B	16 h6	18	5	30	79.5	M6x16	① K050.5.006 PAM71 ② K050.5.007 PAM80
type S	14 h6	16	5	30	79.5	M5x10	① KS050.5.008 PAM71 ② KS050.5.009 PAM80

	b1	c1	d1	e1	f1	l1	m1	n1	t2	o1
type B	8	52	25 ^{-0.005} _{-0.020}	59.5	81	200	86.5	146	28	M8x20
type S	8	50	24 ^{-0.005} _{-0.020}	68.8	81	218	86.5	155	27	M8x20



QUICK SELECTION / Selezione veloce

input speed (n_1) = 1400 min⁻¹

Output Speed n_2 [min ⁻¹]	Ratio i	Motor power P_{1M} [kW]	Output torque M_{2M} [Nm]	Service factor f.s.	Nominal power P_{1R} [kW]	Nominal torque M_{2R} [Nm]	Available B5 motor flanges				Available B14 motor flanges			Dynamic efficiency RD	Tooth Module [mm]	 Ratios code	
							B	C	D	E	Q	R	T				
							63	71	80	90	71	80	90				
200	7	1.8	71	1.8	3.2	125		B	B			B-C	B-C		83	3.1	01
140	10	1.8	99	1.4	2.4	134		B	B			B-C	B-C		81	3.1	02
93	15	1.5	121	1.1	1.7	138		B	B			B-C	B-C		79	3.1	03
74	19	1.1	111	1.2	1.4	138		B	B			B-C	B-C		78	2.6	04
58	24	1.1	135	1.0	1.2	142		B	B			B-C	B-C		75	2.0	05
47	30	1.1	167	0.9	0.96	146		B	B			B-C	B-C		74	3.2	06
39	36	0.75	125	1.2	0.88	147		B	B	B		B-C	B-C		68	2.7	07
31	45	0.55	111	1.2	0.67	135	B	B				B-C	C		66	2.1	08
23	60	0.55	140	0.9	0.51	130	B	B				B-C	C		62	1.6	12
21	67	0.55	151	0.8	0.45	124	B	B				B-C	C		60	1.5	09
17.5	80	0.37	115	1.0	0.38	119	B	B				B-C	C		57	1.3	10
14.9	94	0.37	123	1.0	0.36	119	B	B				B-C	C		52	1.1	11

A Motor Flanges Available
Flange Motore Disponibili

B Supplied with Reduction Bushing
Fornito con Bussola di Riduzione

B Available on Request without reduction bushing
Disponibile a Richiesta senza Bussola di Riduzione

C Motor Flange Holes Position
Posizione Fori Flangia Motore

EN Unit **Q63** is supplied with synthetic oil, providing "long life" lubrication. For mounting position V5-V6 please contact us. See table 1 for lubrication and recommended quantity. In table 2 please see possible radial loads and axial loads on the gearbox.

I Il riduttore tipo **Q63** viene fornito lubrificato a vita con olio sintetico. Per posizioni V5-V6 contattare il ns. servizio tecnico. Vedi tab.1 per oli e quantità consigliati. In tab.2 sono presenti i carichi radiali e assiali applicabili al riduttore.

D Für die Lebensdauerschmierung ist das Getriebe der Größe **Q63** mit synthetischem Öl befüllt. Bei Einbaulage V5 oder V6 bitten wir um Rücksprache. In Tabelle 1 ist die Schmiermenge und das empfohlene Schmiermittel angegeben. In Tabelle 2 sind die zulässigen Radial- und Axialbelastungen des Getriebes aufgeführt.

F Le réducteur de type **Q63** est fourni lubrifié à vie avec de l'huile synthétique. Concernant les positions V5.V6, contactez notre service d'assistance technique. Voir tableau 1 concernant les huiles et les quantités conseillées. Les charges radiales et axiales applicables au réducteur sont précisées dans le tableau 2.

E El reductor tamaño **Q63** se suministra, lubricado de por vida con aceite sintético. Para las posiciones V5 y V6 contactar con nuestro servicio técnico. Ver tabla 1, para cantidades y aceites recomendados. En la tabla 2, se encuentran las cargas radiales y axiales admitidas por el reductor.

LUBRICATION Q63 Oil Quantity 0.30 Lt.

AGIP Telium VSF 320

SHELL Omala S4 WE 320

For all details on lubrication and plugs check our website **tab. 1**
Per maggiori dettagli su lubrificazione e tappi olio vedi il nostro sito web

RADIAL AND AXIAL LOADS

Output shaft

Albero di uscita

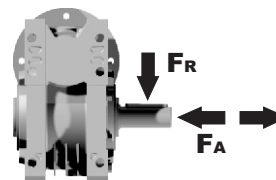

n_2 [min ⁻¹]	FA [N]	FR [N]
200	360	1800
150	400	2000
100	460	2300
75	500	2500
50	600	3000
25	700	3800
15	800	4000

Input shaft

albero in entrata

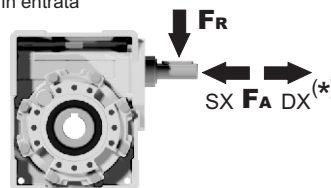

n_1 [min ⁻¹]	FA [N]	FR [N]
1400	90	450

***Strong axial loads in the DX direction are not allowed.**
Non sono consentiti forti carichi assiali con direzione DX

tab. 2

PQ63FB... Basic wormbox
Riduttore base

Gearbox weight
peso riduttore **6.00 kg**

M. flanges	Kit code	øF	A
63B5	K063.4.041	140	99.5
71B5	K063.4.042	160	97.5
80/90B5	K063.4.043	200	99.5
71B14	K063.4.047	105	97.5
80B14	K063.4.046	120	99.5
90B14	K063.4.041	140	99.5

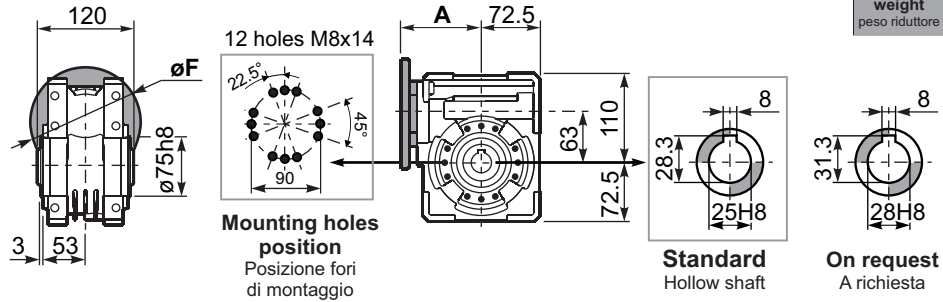

PQ63FC... Square flange
Flangia quadrata

PQ63F1... Round flange
Flangia rotonda

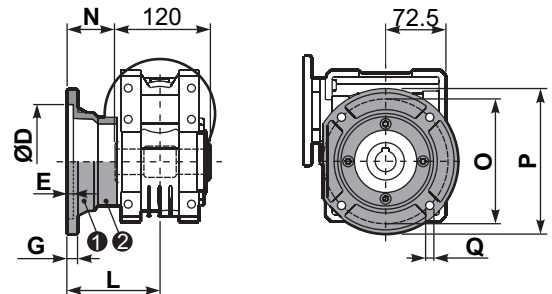
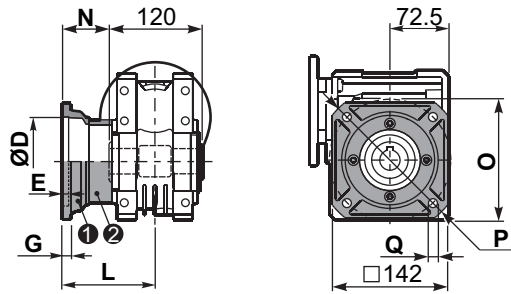

type B	øD	E	G	L	N	O	P	Q	kit code
FC	115 ^{+0.20} / _{+0.15}	6	12	86	26	150	180	11	① KQ63.9.010 ② -
FL	115 ^{+0.20} / _{+0.15}	6	12	116	56	150	180	11	① KQ63.9.010 ② K063.0.200

type S	øD	E	G	L	N	O	P	Q	kit code
F1	130 ^{+0.20} / _{+0.15}	7	13	110	50	165	200	13	① KS070.9.013 ② -
F2	115 ^{+0.20} / _{+0.15}	7	13	124	64	150	175	11	① KS063.9.013 ② -
F3	110 ^{+0.035} / ₀	5	11	90	30	130	160	10	① KS063.9.011 ② -

PQ63FB... Feet
Piedini

PQ63BR... Reaction arm
Braccio di reazione

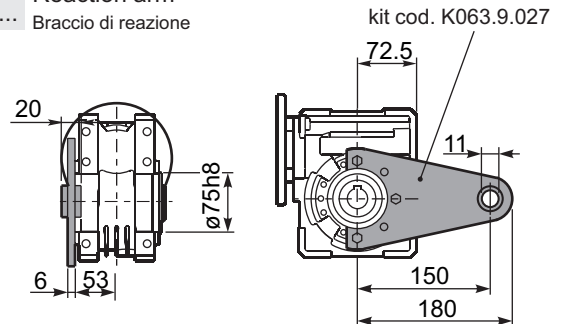
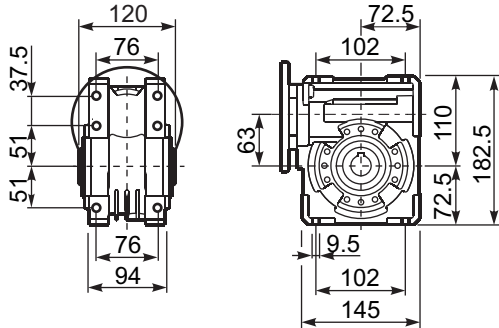

RQ63FB... Input shaft
Albero in entrata

PQ63.....S... Single Shaft
Albero lento semplice

PQ63.....D... Double Shaft
Albero lento bisp.

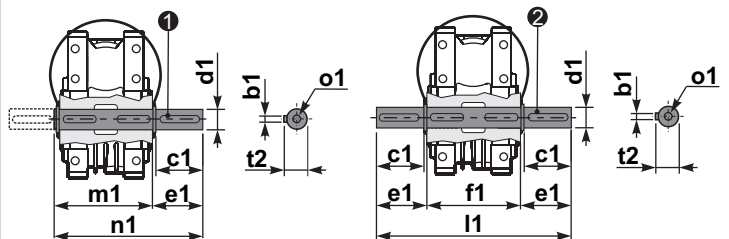
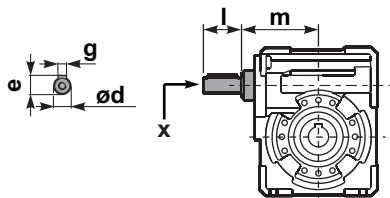

① kit cod. K063.5.028 type B ② kit cod. K063.5.029 type B

	ød	e	g	l	m	x	kit code
type B	18 h6	20.5	6	45	93	M6x16	① K063.5.006 PAM80 ② K063.5.007 PAM90
type S	19 h6	21.5	6	40	93	M8x20	① KS063.5.008 PAM80 ② KS063.5.009 PAM90

	b1	c1	d1	e1	f1	l1	m1	n1	t2	o1
type B	8	60	25 ^{-0.005} / _{-0.020}	63.2	120	246.4	126.8	190	28	M8x20
type S	-	-	-	-	-	-	-	-	-	-



QUICK SELECTION / Selezione veloce

input speed (n_1) = 1400 min⁻¹

Output Speed n_2 [min ⁻¹]	Ratio i	Motor power P_{1M} [kW]	Output torque M_{2M} [Nm]	Service factor f.s.	Nominal power P_{1R} [kW]	Nominal torque M_{2R} [Nm]	Available B5 motor flanges				Available B14 motor flanges			Dynamic efficiency RD	Tooth Module [mm]	Ratios code 	
							C	D	E	F	R	T	U				
							71	80	90	100 112	80	90	100 112				
200	7	4	172	1.1	4.4	190		B	B			B	B		90	3.75	01
140	10	4	240	1.0	3.8	230		B	B			B	B		88	3.75	02
93	15	3	261	1.0	2.9	250		B	B			B	B		85	3.75	03
70	20	2.2	249	1.0	2.2	250		B	B			B	B		83	3.00	04
56	25	1.5	205	1.2	1.8	250	B	B				B			80	2.41	05
45	31	1.5	244	1.1	1.7	270	B	B				B			77	3.75	06
35	40	1.5	295	0.9	1.3	255	B	B				B			72	3.10	07
28	50	0.75	174	1.3	0.95	220	B								68	2.41	08
23	60	0.75	202	1.0	0.75	200	B								65	2.10	09
17.5	80	0.55	177	1.0	0.56	180	B								59	1.53	10
14.0	100	0.55*	206	0.7	0.40	150	B								55	1.23	11

Motor Flanges Available
Flange Motore Disponibili

B) Supplied with Reduction Bushing
Fornito con Bussola di Riduzione

B) Available on Request without reduction bushing
Disponibile a Richiesta senza Bussola di Riduzione

C) Motor Flange Holes Position
Posizione Fori Flangia Motore

EN Unit Q75 is supplied with synthetic oil, providing "long life" lubrication. For mounting position V5-V6 please contact us. See table 1 for lubrication and recommended quantity. In table 2 please see possible radial loads and axial loads on the gearbox.

I Il riduttore tipo Q75 viene fornito lubrificato a vita con olio sintetico. Per posizioni V5-V6 contattare il ns. servizio tecnico. Vedi tab.1 per oli e quantità consigliati. In tab.2 sono presenti i carichi radiali e assiali applicabili al riduttore.

D Für die Lebensdauerschmierung ist das Getriebe der Größe Q75 mit synthetischem Öl befüllt. Bei Einbaulage V5 oder V6 bitten wir um Rücksprache. In Tabelle 1 ist die Schmiermenge und das empfohlene Schmiermittel angegeben. In Tabelle 2 sind die zulässigen Radial- und Axialbelastungen des Getriebes aufgeführt.

F Le réducteur de type Q75 est fourni lubrifié à vie avec de l'huile synthétique. Concernant les positions V5.V6, contactez notre service d'assistance technique. Voir tableau 1 concernant les huiles et les quantités conseillées. Les charges radiales et axiales applicables au réducteur sont précisées dans le tableau 2.

E El reductor tamaño Q75 se suministra, lubricado de por vida con aceite sintético. Para las posiciones V5 y V6 contactar con nuestro servicio técnico. Ver tabla 1, para cantidades y aceites recomendados. En la tabla 2, se encuentran las cargas radiales y axiales admitidas por el reductor.

LUBRICATION Q75 Oil Quantity 0.40 Lt.

AGIP Telium VSF 320

SHELL Omala S4 WE 320

For all details on lubrication and plugs check our website **tab. 1**
Per maggiori dettagli su lubrificazione e tappi olio vedi il nostro sito web

RADIAL AND AXIAL LOADS

Output shaft
Albero di uscita

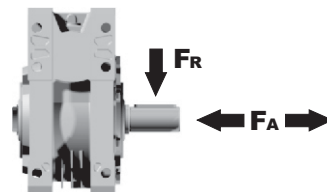

n_2 [min ⁻¹]	FA [N]	FR [N]
200	460	2300
150	520	2600
100	560	2800
75	620	3100
50	720	3600
25	880	4400
15	1000	5000

Input shaft
albero in entrata

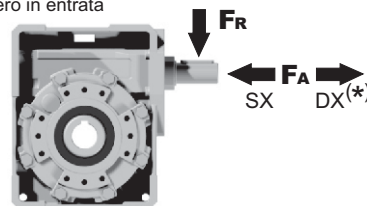

n_1 [min ⁻¹]	FA [N]	FR [N]
1400	125	630

*Strong axial loads in the DX direction are not allowed.
Non sono consentiti forti carichi assiali con direzione DX

tab. 2

PQ75FB... Basic wormbox
Riduttore base

Gearbox weight
peso riduttore **8.70 kg**

M. flanges	Kit code	øF	A
71B5	K023.4.041	160	113.5
80/90B5	K023.4.042	200	115.5
100/112B5	K023.4.043	250	124.5
80B14	K085.4.046	120	115.5
90B14	K085.4.045	140	115.5
100/112B14	K023.4.041	160	113.5

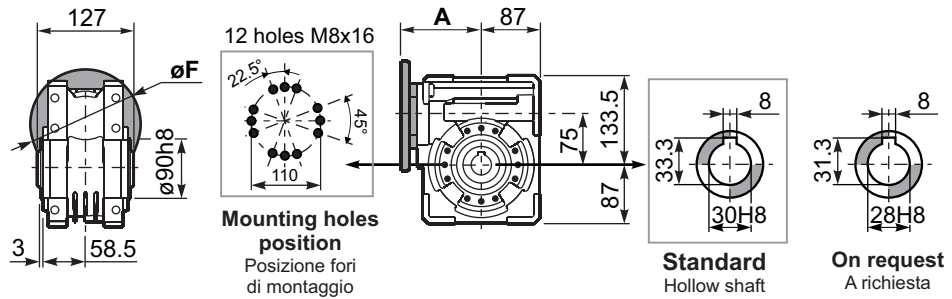

PQ75FC... Square flange
Flangia quadrata

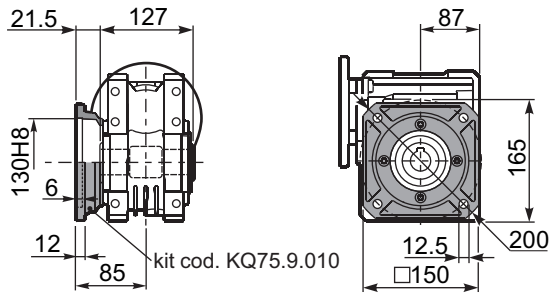

PQ75FL... Square flange
Flangia quadrata

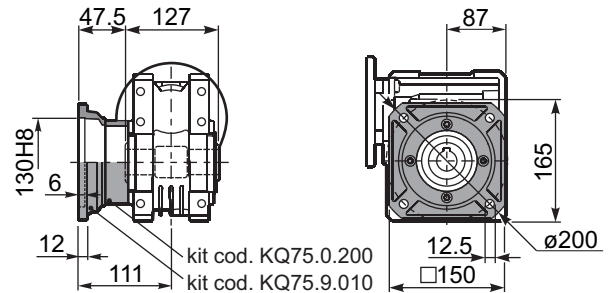

PQ75FB... Feet
Piedini

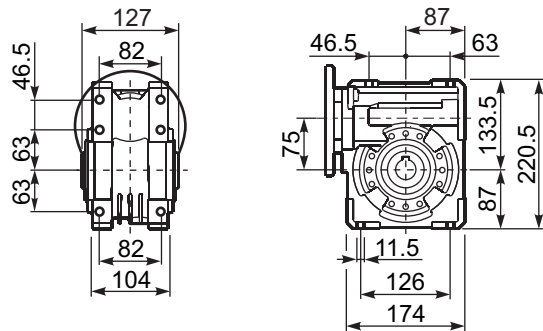

PQ75BR... Reaction arm
Braccio di reazione

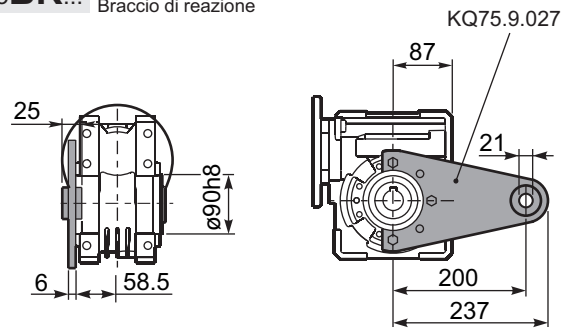

RQ75FB... Input shaft
Albero in entrata

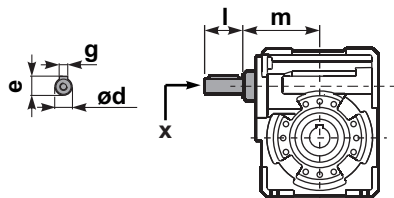

PQ75.....S... Single Shaft
Albero lento semplice

PQ75.....D... Double Shaft
Albero lento bisp.

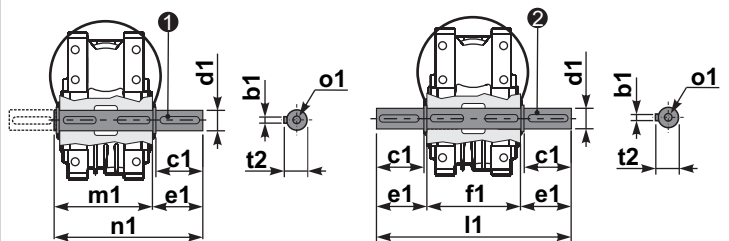

① kit cod. KQ75.5.028 Standard
kit cod. KQ75.5.026 On request
 ② kit cod. KQ75.5.029 Standard
kit cod. KQ75.5.027 On request

	ød	e	g	l	m	x	kit code
type B	25 h6	27.8	8	50	109.5	M8x20	KQ75.5.006 PAM80 K085.5.007 PAM90 K085.5.008 PAM100

	b1	c1	d1	e1	f1	l1	m1	n1	t2	o1
Standard	8	60	30 ^{-0.005} _{-0.020}	65	127	255	134	199	33	M8x20
On request	8	60	28 ^{-0.005} _{-0.020}	65	127	255	134	199	31	M8x20



QUICK SELECTION / Selezione veloce

input speed (n_1) = 1400 min⁻¹

Output Speed n_2 [min ⁻¹]	Ratio i	Motor power P_{1M} [kW]	Output torque M_{2M} [Nm]	Service factor f.s.	Nominal power P_{1R} [kW]	Nominal torque M_{2R} [Nm]	Available B5 motor flanges				Available B14 motor flanges			Dynamic efficiency RD	Tooth Module [mm]	Ratios code	
							C	D	E	F	R	T	U				
							71	80	90	100 112	80	90	100 112				
200	7	4.0	168	1.5	6.1	257		B	B			B	B		88	4.23	01
140	10	4.0	218	1.3	5.2	284		B	B			B	B		80	4.2	02
100	14	3.0	223	1.4	4.1	305		B	B			B	B		78	4.5	03
70	20	2.2	237	1.2	2.7	294		B	B			B	B		79	3.4	04
64	22	2.2	258	1.1	2.5	294		B	B			B	B		78	3.1	05
50	28	2.2	315	1.1	2.4	347		B	B	B		B	B		75	4.7	06
37	38	1.5	276	1.2	1.8	336	B	B				B			71	3.5	07
30	46	1.5	320	1.0	1.5	326	B	B				B			68	3.1	08
27	52	1.1	258	1.1	1.2	289	B	B				B			66	2.7	09
21	67	1.1	327	0.9	0.97	289	B	B				B			65	2.1	10
18.9	74	0.75	220	1.2	0.91	268	B	B				B			58	1.9	11
14.6	96	0.55	191	1.3	0.70	242	B	B				B			53	1.5	12

A Motor Flanges Available
Flange Motore Disponibili

B Supplied with Reduction Bushing
Fornito con Bussola di Riduzione

B Available on Request without reduction bushing
Disponibile a Richiesta senza Bussola di Riduzione

C Motor Flange Holes Position
Posizione Fori Flangia Motore

EN Unit Q85 is supplied with synthetic oil, providing "long life" lubrication. For mounting position V5-V6 please contact us. See table 1 for lubrication and recommended quantity. In table 2 please see possible radial loads and axial loads on the gearbox.

I Il riduttore tipo Q85 viene fornito lubrificato a vita con olio sintetico. Per posizioni V5-V6 contattare il ns. servizio tecnico. Vedi tab.1 per oli e quantità consigliati. In tab.2 sono presenti i carichi radiali e assiali applicabili al riduttore.

D Für die Lebensdauerschmierung ist das Getriebe der Größe Q85 mit synthetischem Öl befüllt. Bei Einbaulage V5 oder V6 bitten wir um Rücksprache. In Tabelle 1 ist die Schmiermenge und das empfohlene Schmiermittel angegeben. In Tabelle 2 sind die zulässigen Radial- und Axialbelastungen des Getriebes aufgeführt.

F Le réducteur de type Q85 est fourni lubrifié à vie avec de l'huile synthétique. Concernant les positions V5.V6, contactez notre service d'assistance technique. Voir tableau 1 concernant les huiles et les quantités conseillées. Les charges radiales et axiales applicables au réducteur sont précisées dans le tableau 2.

E El reductor tamaño Q85 se suministra, lubricado de por vida con aceite sintético. Para las posiciones V5 y V6 contactar con nuestro servicio técnico. Ver tabla 1, para cantidades y aceites recomendados. En la tabla 2, se encuentran las cargas radiales y axiales admitidas por el reductor.

LUBRICATION Q85 Oil Quantity 1.20 Lt.

AGIP Telium VSF 320

SHELL Omala S4 WE 320

For all details on lubrication and plugs check our website **tab. 1**
Per maggiori dettagli su lubrificazione e tappi olio vedi il nostro sito web

RADIAL AND AXIAL LOADS

Output shaft

Albero di uscita

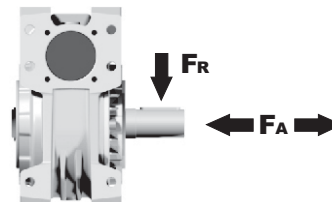

n_2 [min ⁻¹]	FA [N]	FR [N]
200	500	2500
150	580	2900
100	600	3000
75	700	3500
50	800	4000
25	1000	5000
15	1160	5800

Input shaft

albero in entrata

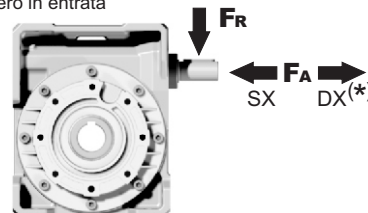

n_1 [min ⁻¹]	FA [N]	FR [N]
1400	160	809

***Strong axial loads in the DX direction are not allowed.**
Non sono consentiti forti carichi assiali con direzione DX

tab. 2

PQ85FB... Basic wormbox
Riduttore base

Gearbox weight
peso riduttore **12.1 kg**

M. flanges	Kit code	øF	A
71B5	K023.4.041	160	116
80/90B5	K023.4.042	200	118
100/112B5	K023.4.043	250	127
80B14	K085.4.046	120	118
90B14	K085.4.045	140	118
100/112B14	K023.4.041	160	116

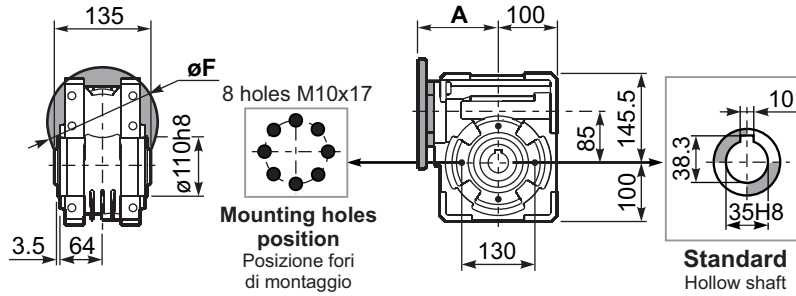

PQ85FC... Output flange
Flangia uscita

PQ85F1... Output flange
Flangia uscita

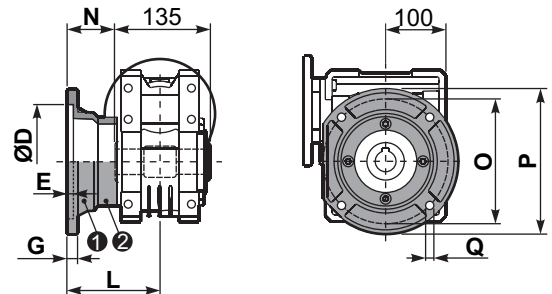
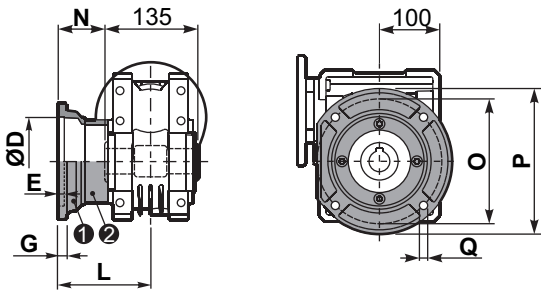

type B	øD	E	G	L	N	O	P	Q	kit code
FC	152 ^{+0.06} / _{+0.00}	5	16	108	40.5	176	205	13	① K085.9.010 ② -
FL	152 ^{+0.06} / _{+0.00}	5	16	148.5	81	176	205	13	① K085.9.010 ② K085.0.201

type S	øD	E	G	L	N	O	P	Q	kit code
F1	130 H7	5	13	117.5	50	165	200	11.5	① KS085.9.012 ② -
F2	152 ^{+0.06} / _{+0.00}	5	15	147.5	80	180	205	12.5	① KS085.9.013 ② -
F4	130 H7	5	13	106.5	39	165	200	13	① KS085.9.015 ② -

PQ85FB... Feet
Piedini

PQ85BR... Reaction arm
Braccio di reazione

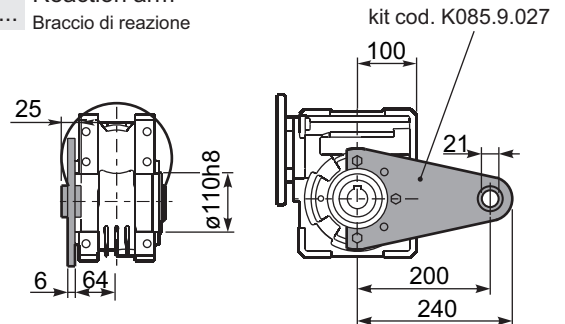
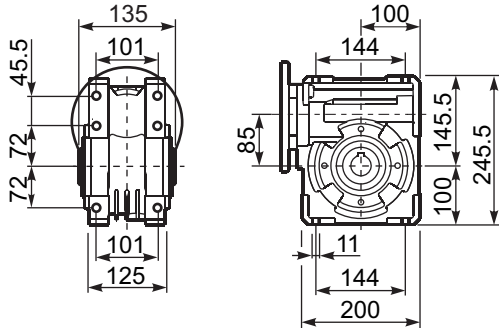

RQ85FB... Input shaft
Albero in entrata

PQ85.....S... Single Shaft
Albero lento semplice

PQ85.....D... Double Shaft
Albero lento bisp.

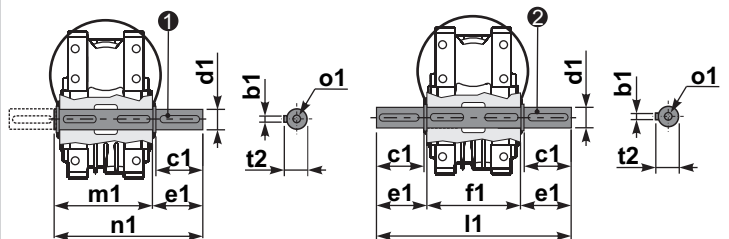
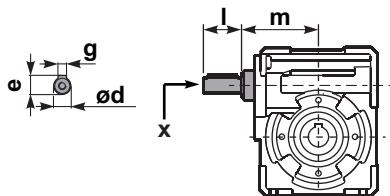

① kit cod. K085.5.028 type B ② kit cod. K085.5.029 type B

	ød	e	g	l	m	x	kit code
type B	25 h6	28	8	50	112	M8x20	① K085.5.007 PAM90 ② K085.5.008 PAM100
type S	24 h6	27	8	50	112	M8x20	① KS085.5.009 PAM90 ② KS085.5.011 PAM100

	b1	c1	d1	e1	f1	l1	m1	n1	t2	o1
type B	10	60	35 ^{-0.005} / _{-0.020}	73.5	135	282	141	214.5	38	M10x23
type S	-	-	-	-	-	-	-	-	-	-



QUICK SELECTION / Selezione veloce

input speed (n_1) = 1400 min⁻¹

Output Speed n_2 [min ⁻¹]	Ratio i	Motor power P_{1M} [kW]	Output torque M_{2M} [Nm]	Service factor f.s.	Nominal power P_{1R} [kW]	Nominal torque M_{2R} [Nm]	Available B5 motor flanges					Available B14 motor flanges				Dynamic efficiency RD	Tooth Module [mm]	Ratios code	
							C	D	E	F	G	R	T	U	V				
							71	80	90	100 112	132	80	90	100 112	132				
200	7	7.5	315	1.5	11.5	483		B	B				B	B			88	5.5	01
140	10	7.5	440	1.2	9.0	525		B	B				B	B			86	5.4	02
88	16	5.5	492	1.1	6.0	536		B	B				B	B			82	5.3	03
70	20	4.0	447	1.2	4.9	546		B	B				B	B			82	4.5	04
61	23	3.0	377	1.4	4.1	515		B	B				B	B			80	3.9	05
47	30	3.0	467	1.4	4.2	651		B	B				B	B			76	5.6	06
37	38	3.0	583	1.1	3.3	641		B	B				B	B			75	4.7	07
31	45	2.2	493	1.2	2.7	599		B	B				B	B			73	4.0	08
26	53	2.2	557	1.1	2.5	620		B	B				B	B			70	3.5	09
22	64	1.5	452	1.2	1.8	536	B	B					B	B			69	2.9	10
16.7	84	1.1	410	1.2	1.3	494	B	B					B	B			65	2.2	11
14.1	99	1.1	446	1.1	1.2	483	B	B					B	B			60	1.9	12

Motor Flanges Available Flange Motore Disponibili
 B Supplied with Reduction Bushing Fornito con Bussola di Riduzione
 B) Available on Request without reduction bushing Disponibile a Richiesta senza Bussola di Riduzione
 C Motor Flange Holes Position Posizione Fori Flangia Motore

EN Unit Q11 is supplied without lubricant and equipped with a breather, level and drain plugs. User can add mineral oil keeping existing plugs. Should the user wish to fill it with synthetic oil, it is recommended to replace the existing plugs with a closed plug. See table 1 for lubrication and recommended quantity. In table 2 please see possible radial loads and axial loads on the gearbox.

I Il riduttore tipo Q11 è fornito privo di lubrificazione con tappi di sfiato, livello e scarico olio. L'utente può immettere olio minerale mantenendo i tappi esistenti. Se immetterà olio sintetico, dovrà sostituire i tappi esistenti con altri tipo chiuso. Tab.1 per oli e quantità consigliati. Tab.2 carichi radiali e assiali applicabili al riduttore.

D Das Getriebe der Baugröße Q11 wird ohne Schmiermittel geliefert. Es ist jedoch mit Einfüllschraube, Überdruckventil und Ablassschraube ausgerüstet. Das benötigte mineralische Öl kann über die Einfüllschraube eingefüllt werden. Sollte synthetisches Öl bevorzugt werden, so ist sind das eingebaute Überdruckventil durch eine geschlossenen Schraube zu ersetzen. In Tabelle 1 ist die Schmiermenge und das empfohlene Schmiermittel angegeben. In Tabelle 2 sind die zulässigen Radial - und Axialbelastungen des Getriebes aufgeführt.

F Le réducteur de type Q11 est fourni sans lubrification et avec un bouchon de remplissage, de niveau et d'évacuation de l'huile. L'utilisateur peut y verser de l'huile minérale en conservant les bouchons existants. S'il y versera de l'huile synthétique, il devra substituer les bouchons existants avec d'autres bouchons de type fermé. Voir tableau 1 concernant les huiles et les quantités conseillées. Voir tableau 2 concernant les charges radiales et axiales applicables au réducteur.

E El reductor tamaño Q11 se suministra sin lubricante, provisto de tapones de respiración, nivel y descarga de aceite. El usuario puede utilizar aceite mineral, manteniendo los tapones existentes. Si prefiere utilizar aceite sintético deberá sustituir los tapones existentes por tapones ciegos. La prerreducción se suministra con tapones ciegos, lubricado de por vida con aceite sintético. Ver tabla 1, para cantidades y aceites recomendados. En la tabla 2, se encuentran las cargas radiales y axiales admitidas por el reductor.

B3	B6	B7	B8	V5	V6
2.00 LT	1.50 LT	1.50 LT	2.00LT	2.00 LT	2.00LT

AGIP Blasias 460

For all details on lubrication and plugs check our website [tab. 1](#)
Per maggiori dettagli su lubrificazione e tappi olio vedi il nostro sito web

RADIAL AND AXIAL LOADS

Output shaft Albero di uscita

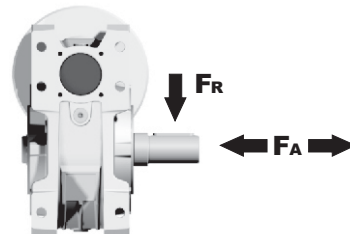

n_2 [min ⁻¹]	FA [N]	FR [N]
200	600	2900
150	700	3300
100	750	3600
75	800	4000
50	920	4600
25	1200	6000
15	1400	7000

Input shaft albero in entrata

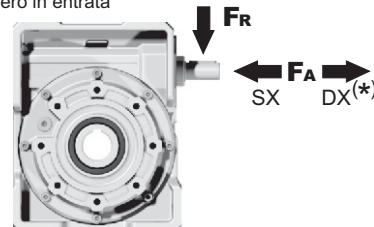

n_1 [min ⁻¹]	FA [N]	FR [N]
1400	228	1140

*Strong axial loads in the DX direction are not allowed.
Non sono consentiti forti carichi assiali con direzione DX

tab. 2

PQ11FB... Basic wormbox
Riduttore base

Gearbox weight
peso riduttore **35.0 kg**

M. flanges	Kit code	øF	A
71B5	K023.4.041	160	135.5
80/90B5	K023.4.042	200	137.5
100/112B5	K023.4.043	250	146.5
132B5	-	300	187
80B14	K085.4.046	120	137.5
90B14	K085.4.045	140	137.5
100/112B14	K023.4.041	160	135.5
132B14	-	200	187

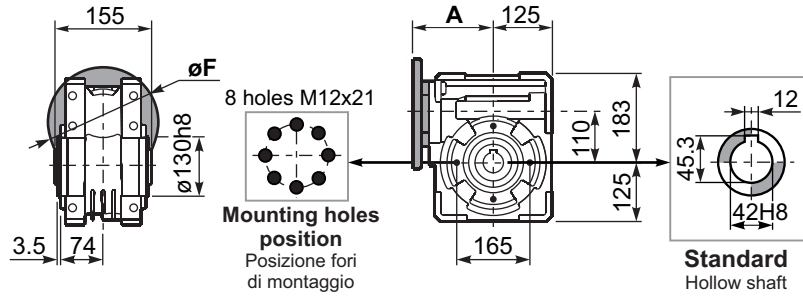

PQ11FC... Output flange
Flangia uscita

PQ11F1... Output flange
Flangia uscita

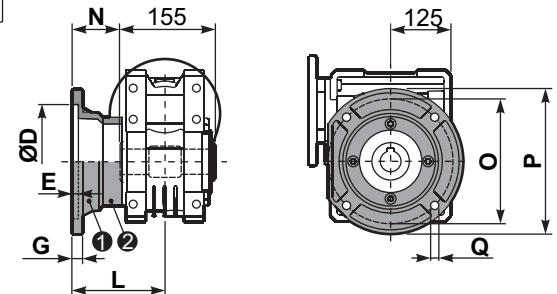
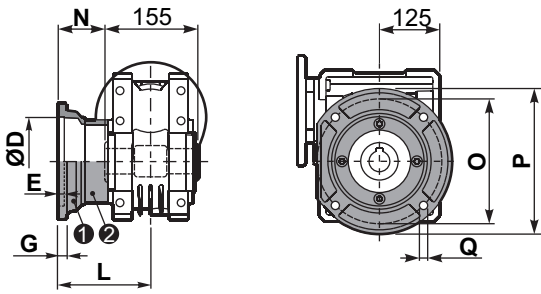

type B	øD	E	G	L	N	O	P	Q	kit code
FC	170 ^{+0.083} / _{+0.043}	11	16.5	131.5	54	230	270	13	① K110.9.010 ② -
FL	170 ^{+0.083} / _{+0.043}	11	16.5	179.5	102	230	270	13	① K110.9.011 ② -

type S	øD	E	G	L	N	O	P	Q	kit code
F1	180 ^{+0.040} / ₀	5	18	150	72.5	215	250	15	① KS110.9.014 ② -
F2	170 ^{+0.083} / _{+0.043}	9.5	15	178	100.5	230	270	13	① KS110.9.012 ② -
F3	180 ^{+0.040} / ₀	5	18	130	52.5	215	250	15	① KS110.9.013 ② -

PQ11FB... Feet
Piedini

PQ11BR... Reaction arm
Braccio di reazione

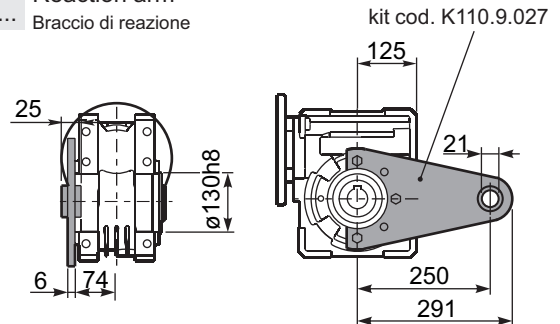
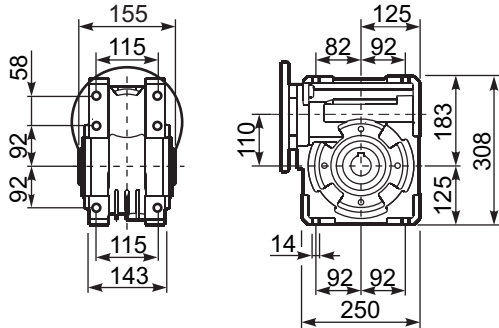

RQ11FB... Input shaft
Albero in entrata

PQ11.....S... Single Shaft
Albero lento semplice

PQ11.....D... Double Shaft
Albero lento bisp.

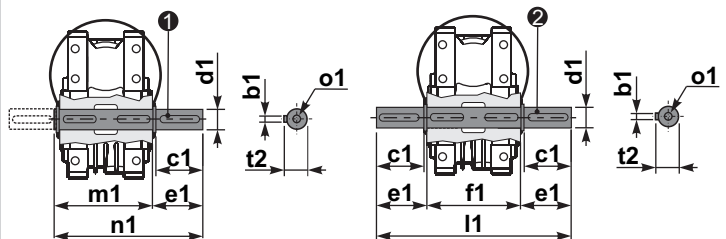
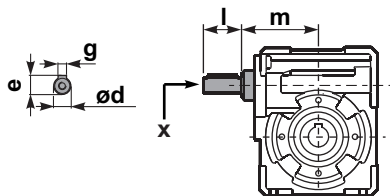

① kit cod. K110.5.028 type B ② kit cod. K110.5.029 type B

	ød	e	g	l	m	x	kit code
type B	25 h6	28	8	50	131.5	M8x20	① K085.5.007 PAM90 ② K085.5.008 PAM100
type S	24 h6	27	8	50	131.5	M8x20	① KS085.5.009 PAM90 ② KS085.5.011 PAM100

	b1	c1	d1	e1	f1	l1	m1	n1	t2	o1
type B	12	75	42 ^{-0.005} / _{-0.020}	96.5	155	348	163.5	260	45	M12x32
type S	-	-	-	-	-	-	-	-	-	-



QUICK SELECTION / Selezione veloce

input speed (n_1) = 1400 min⁻¹

Output Speed n_2 [min ⁻¹]	Ratio i	Motor power P_{1M} [kW]	Output torque M_{2M} [Nm]	Service factor f.s.	Nominal power P_{1R} [kW]	Nominal torque M_{2R} [Nm]	Available B5 motor flanges			B14 motor flanges not available				Dynamic efficiency RD	Tooth Module [mm]	Ratios code
							E	F	G	-	-	-	-			
							90	100 112	132	-	-	-	-			
187	7.5	7.5	345	2.1	16.1	741		B					90	6.11	01	
140	10	7.5	455	1.8	13.5	820		B					89	6.45	02	
93	15	7.5	668	1.4	10.3	917		B					87	6.72	03	
70	20	7.5	870	1.0	7.8	905		B					85	5.24	04	
56	25	5.5	788	1.2	6.5	931		B					84	4.28	05	
46.7	30	5.5	900	1.2	6.4	1047		B					80	6.91	06	
35	40	4.0	851	1.2	4.9	1043		B					78	5.36	07	
28	50	4.0	1023	0.9	3.8	972	B						75	4.35	08	
23.3	60	3.0	896	1.0	3.1	928	B						73	3.65	09	
17.5	80	2.2	816	1.0	2.3	853	B						68	2.76	10	
14	100	1.5	655	1.1	1.7	742	B						64	2.23	11	

A) Motor Flanges Available
Flange Motore Disponibili

B) Supplied with Reduction Bushing
Fornito con Bussola di Riduzione

B) Available on Request without reduction bushing
Disponibile a Richiesta senza Bussola di Riduzione

C) Motor Flange Holes Position
Posizione Fori Flangia Motore

EN Unit Q13 is supplied without lubricant and equipped with a breather, level and drain plugs. User can add mineral oil keeping existing plugs. Should the user wish to fill it with synthetic oil, it is recommended to replace the existing plugs with a closed plug. See table 1 for lubrication and recommended quantity. In table 2 please see possible radial loads and axial loads on the gearbox.

I Il riduttore tipo Q13 è fornito privo di lubrificazione con tappi di sfiato, livello e scarico olio. L'utente può immettere olio minerale mantenendo i tappi esistenti. Se immetterà olio sintetico, dovrà sostituire i tappi esistenti con altri tipo chiuso. Tab.1 per oli e quantità consigliati. Tab.2 carichi radiali e assiali applicabili al riduttore.

D Das Getriebe der Baugröße Q13 wird ohne Schmiermittel geliefert. Es ist jedoch mit Einfüllschraube, Überdruckventil und Ablassschraube ausgerüstet. Das benötigte mineralische Öl kann über die Einfüllschraube eingefüllt werden. Sollte synthetisches Öl bevorzugt werden, so ist sind das eingebaute Überdruckventil durch eine geschlossenen Schraube zu ersetzen. In Tabelle 1 ist die Schmiermenge und das empfohlene Schmiermittel angegeben. In Tabelle 2 sind die zulässigen Radial - und Axialbelastungen des Getriebes aufgeführt.

F Le réducteur de type Q13 est fourni sans lubrification et avec un bouchon de remplissage, de niveau et d'évacuation de l'huile. L'utilisateur peut y verser de l'huile minérale en conservant les bouchons existants. S'il y versera de l'huile synthétique, il devra substituer les bouchons existants avec d'autres bouchons de type fermé. Voir tableau 1 concernant les huiles et les quantités conseillées. Voir tableau 2 concernant les charges radiales et axiales applicables au réducteur.

E El reductor tamaño Q13 se suministra sin lubricante, provisto de tapones de respiración, nivel y descarga de aceite. El usuario puede utilizar aceite mineral, manteniendo los tapones existentes. Si prefiere utilizar aceite sintético deberá sustituir los tapones existentes por tapones ciegos. La prerreducción se suministra con tapones ciegos, lubricado de por vida con aceite sintético. Ver tabla 1, para cantidades y aceites recomendados. En la tabla 2, se encuentran las cargas radiales y axiales admitidas por el reductor.

B3	B6	B7	B8	V5	V6
4.50 LT	3.50 LT	3.50 LT	3.30LT	4.50 LT	3.30LT

AGIP Blasias 460

For all details on lubrication and plugs check our website [tab. 1](#)
Per maggiori dettagli su lubrificazione e tappi olio vedi il nostro sito web

RADIAL AND AXIAL LOADS

Output shaft
Albero di uscita

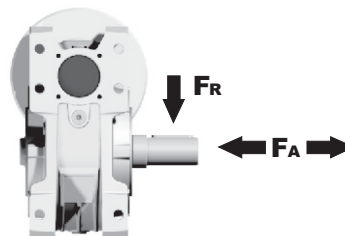

n_2 [min ⁻¹]	FA [N]	FR [N]
200	960	4800
150	1100	5500
100	1240	6200
75	1380	6900
50	1560	7800
25	2000	10000
15	2400	12000

Input shaft
albero in entrata

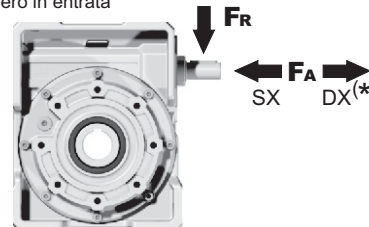

n_1 [min ⁻¹]	FA [N]	FR [N]
1400	300	1500

*Strong axial loads in the DX direction are not allowed.
Non sono consentiti forti carichi assiali con direzione DX

tab. 2

PQ13**FB**... Basic wormbox
Riduttore base

Gearbox weight
peso riduttore **48.0 kg**

M. flanges	Kit code	øF	A
90B5	KQ13.4.041	200	180
100/112B5	KQ13.4.042	250	180
132B5	KQ13.4.043	300	180

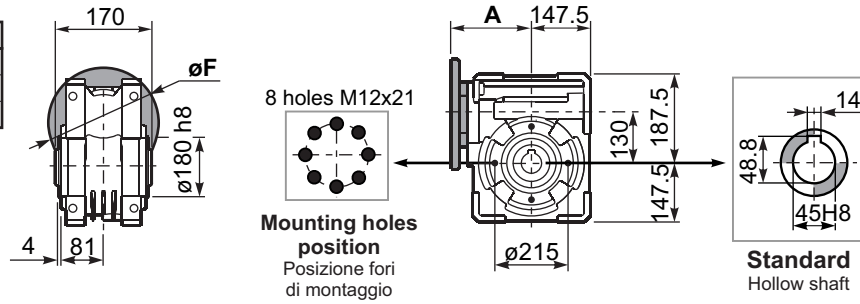

PQ13**FC**... Square flange
Flangia quadrata

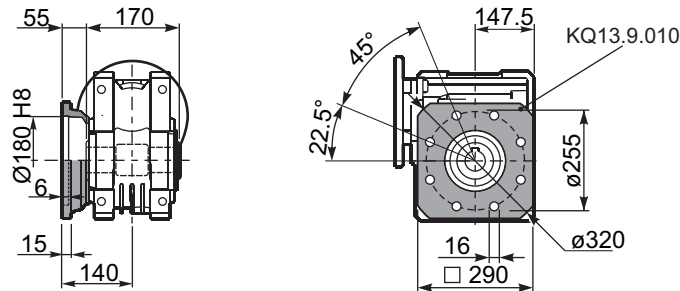

PQ13**FB**... Feet
Piedini

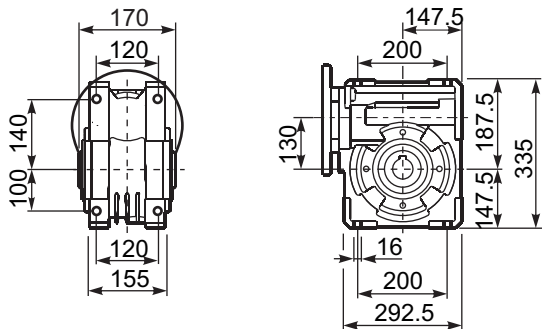

PQ13**BR**... Reaction arm
Braccio di reazione

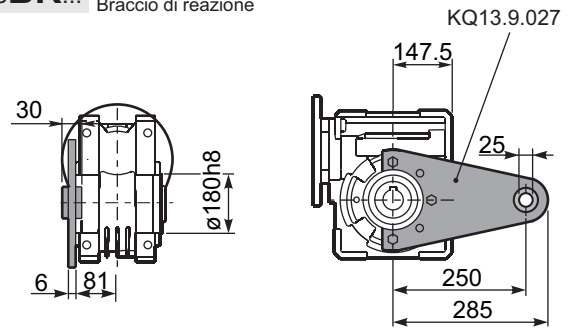

PQ13.....**S**... Single Shaft
Albero lento semplice

PQ13.....**D**... Double Shaft
Albero lento bisp.

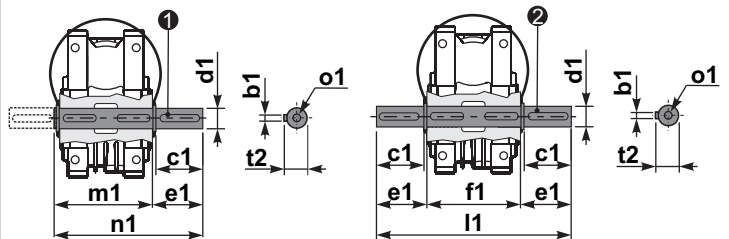

① kit cod. KQ13.5.028 type B

② kit cod. KQ13.5.029 type B

	b1	c1	d1	e1	f1	l1	m1	n1	t2	o1
type	14	80	45 ^{-0.005} _{-0.020}	85	170	340	180	265	48.5	M16
type	-	-	-	-	-	-	-	-	-	-



QUICK SELECTION / Selezione veloce

input speed (n_1) = 1400 min⁻¹

Output Speed n_2 [min ⁻¹]	Ratio i	Motor power P_{1M} [kW]	Output torque M_{2M} [Nm]	Service factor f.s.	Nominal power P_{1R} [kW]	Nominal torque M_{2R} [Nm]	Available B5 motor flanges			B14 motor flanges not available				Dynamic efficiency RD	Tooth Module [mm]	Ratios code
							F	G	H	-	-	-	-			
							100	132	160	-	-	-	-			
187	7.5	15	698	1.7	25.8	1200		B						91	5.5	01
140	10	15	921	1.3	20.2	1240		B						90	6.155	02
93	15	11	990	1.3	13.9	1250		B						88	5.5	03
70	20	11	1291	1.0	11.1	1300		B						86	6.155	04
56	25	9	1289	0.9	8.4	1200		B						84	5	05
46.7	30	7.5	1274	0.9	7.1	1200	B							83	4.193	06
35	40	7.5	1596	1.0	7.3	1550	B							78	6.155	07
28	50	5.5	1426	1.0	5.4	1400	B							76	5	08
23.3	60	4	1195	1.1	4.2	1260	B							73	4.193	09
17.5	80	3	1113	1.0	3.1	1150								68	3.17	10
14	100	2.2	960	1.0	2.3	1000								64	2.55	11

A) Motor Flanges Available
Flange Motore Disponibili

B) Supplied with Reduction Bushing
Fornito con Bussola di Riduzione

B) Available on Request without reduction bushing
Disponibile a Richiesta senza Bussola di Riduzione

C) Motor Flange Holes Position
Posizione Fori Flangia Motore

EN Unit Q15 is supplied without lubricant and equipped with a breather, level and drain plugs. User can add mineral oil keeping existing plugs. Should the user wish to fill it with synthetic oil, it is recommended to replace the existing plugs with a closed plug. See table 1 for lubrication and recommended quantity. In table 2 please see possible radial loads and axial loads on the gearbox.

I Il riduttore tipo Q15 è fornito privo di lubrificazione con tappi di sfiato, livello e scarico olio. L'utente può immettere olio minerale mantenendo i tappi esistenti. Se immetterà olio sintetico, dovrà sostituire i tappi esistenti con altri tipo chiuso. Tab.1 per oli e quantità consigliati. Tab.2 carichi radiali e assiali applicabili al riduttore.

D Das Getriebe der Baugröße Q15 wird ohne Schmiermittel geliefert. Es ist jedoch mit Einfüllschraube, Überdruckventil und Ablassschraube ausgerüstet. Das benötigte mineralische Öl kann über die Einfüllschraube eingefüllt werden. Sollte synthetisches Öl bevorzugt werden, so ist sind das eingebaute Überdruckventil durch eine geschlossenen Schraube zu ersetzen. In Tabelle 1 ist die Schmiermenge und das empfohlene Schmiermittel angegeben. In Tabelle 2 sind die zulässigen Radial - und Axialbelastungen des Getriebes aufgeführt.

F Le réducteur de type Q15 est fourni sans lubrification et avec un bouchon de remplissage, de niveau et d'évacuation de l'huile. L'utilisateur peut y verser de l'huile minérale en conservant les bouchons existants. S'il y versera de l'huile synthétique, il devra substituer les bouchons existants avec d'autres bouchons de type fermé. Voir tableau 1 concernant les huiles et les quantités conseillées. Voir tableau 2 concernant les charges radiales et axiales applicables au réducteur.

E El reductor tamaño Q15 se suministra sin lubricante, provisto de tapones de respiración, nivel y descarga de aceite. El usuario puede utilizar aceite mineral, manteniendo los tapones existentes. Si prefiere utilizar aceite sintético deberá sustituir los tapones existentes por tapones ciegos. La prerreducción se suministra con tapones ciegos, lubricado de por vida con aceite sintético. Ver tabla 1, para cantidades y aceites recomendados. En la tabla 2, se encuentran las cargas radiales y axiales admitidas por el reductor.

B3	B6	B7	B8	V5	V6
7.00 LT	5.40 LT	5.40 LT	5.10 LT	7.00 LT	5.10 LT

AGIP Blasias 460

For all details on lubrication and plugs check our website [tab. 1](#)
Per maggiori dettagli su lubrificazione e tappi olio vedi il nostro sito web

RADIAL AND AXIAL LOADS

Output shaft
Albero di uscita

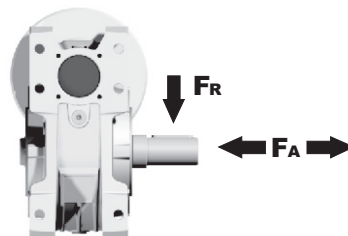

n_2 [min ⁻¹]	FA [N]	FR [N]
200	1300	6500
150	1440	7200
100	1640	8200
75	1800	9000
50	2120	10600
25	2700	13500
15	3300	16500

Input shaft
albero in entrata

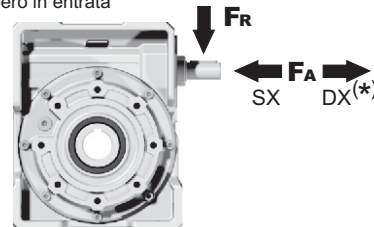

n_1 [min ⁻¹]	FA [N]	FR [N]
1400	400	2000

***Strong axial loads in the DX direction are not allowed.**
Non sono consentiti forti carichi assiali con direzione DX

tab. 2

PQ15**FB**... Basic wormbox
Riduttore base

Gearbox weight
peso riduttore **84.0 kg**

M. flanges	Kit code	øF	A
100/112B5	KQ15.4.042	250	210
132B5	KQ15.4.043	300	210
160B5	KQ15.4.044	350	210

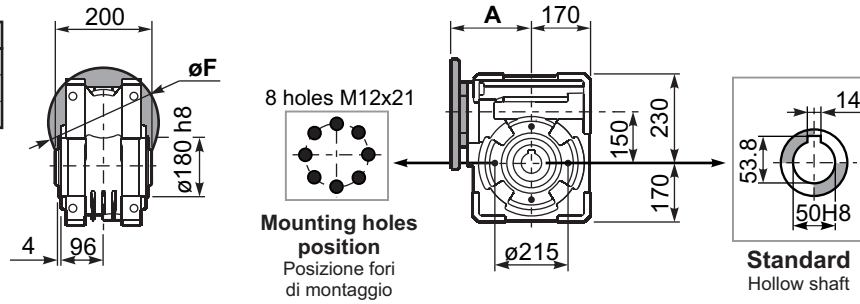

PQ15**FC**... Square flange
Flangia quadrata

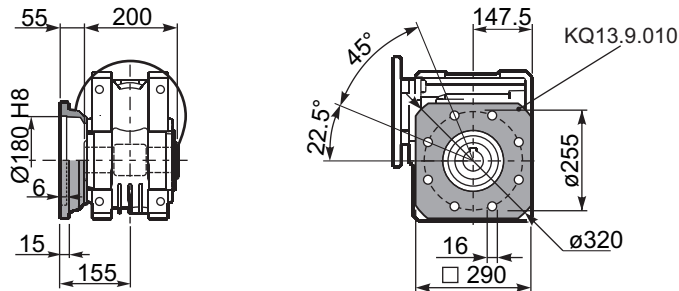

PQ15**FB**... Feet
Piedini

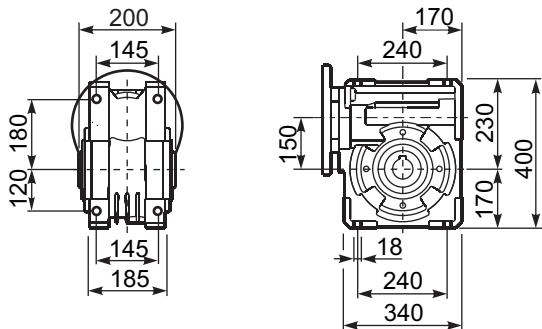

PQ15**BR**... Reaction arm
Braccio di reazione

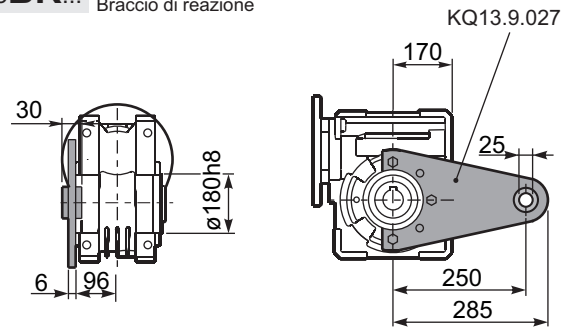

PQ15.....**S**... Single Shaft
Albero lento semplice

PQ15.....**D**... Double Shaft
Albero lento bisp.

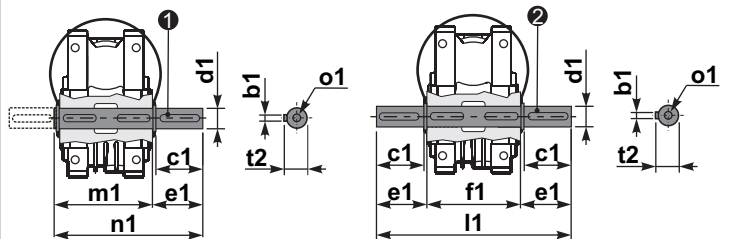

① kit cod. KQ15.5.028 type B

② kit cod. KQ15.5.029 type B

	b1	c1	d1	e1	f1	l1	m1	n1	t2	o1
type	14	82	50 ^{-0.005} _{-0.020}	87	200	374	210	297	53.5	M16
type	-	-	-	-	-	-	-	-	-	-



QUICK SELECTION / Selezione veloce

input speed (n_1) = 1400 min⁻¹

Output Speed n_2 [min ⁻¹]	Ratio i	Motor power P_{1M} [kW]	Output torque M_{2M} [Nm]	Service factor f.s.	Nominal power P_{1R} [kW]	Nominal torque M_{2R} [Nm]	Available B5 motor flanges			Available B14 motor flanges		Dynamic efficiency RD	Tooth Module [mm]	Ratios code
							A	B	C	P	Q			
							56	63	71	63	71			
47	30.1	0.25	38	1.4	0.36	55				C		74	2.2	01
33	43.0	0.25	53	1.0	0.26	55				C		72	2.2	02
23	60.2	0.25	62	0.9	0.22	55				C		60	2.4	03
15.5	90.3	0.12	42	1.3	0.16	55				C		57	1.6	04
11.6	120	0.12	52	1.1	0.13	55				C		53	2.5	05
8.8	159	0.12	64	0.9	0.10	55				C		49	1.8	06
7.1	198	0.12*	55	<0.8	0.09	55				C		47	1.5	07
5.4	258	0.12*	55	<0.8	0.07	55				C		45	1.2	08
4.7	301	0.12*	39	<0.8	0.05	39				C		40	1.0	09
3.2	439	0.12*	39	<0.8	0.04	39				C		36	0.72	10

A) Motor Flanges Available
Flange Motore Disponibili

B) Supplied with Reduction Bushing
Fornito con Bussola di Riduzione

Available on Request without reduction bushing
Disponibile a Richiesta senza Bussola di Riduzione

C) Motor Flange Holes Position
Posizione Fori Flangia Motore

* Power higher than the maximum one which can be supported by the gearbox. Select according to the torque M_{2R}
Potenza superiore a quella massima sopportabile dal riduttore. Selezionare in base al momento torcente M_{2R}

EN Unit **P4Q** is supplied with synthetic oil, providing "long life" lubrication. For mounting position V5-V6 please contact us. See table 1 for lubrication and recommended quantity. In table 2 please see possible radial loads and axial loads on the gearbox.

I Il riduttore tipo **P4Q** viene fornito lubrificato a vita con olio sintetico. Per posizioni V5-V6 contattare il ns. servizio tecnico. Vedi tab.1 per oli e quantità consigliati. In tab.2 sono presenti i carichi radiali e assiali applicabili al riduttore.

D Für die Lebensdauerschmierung ist das Getriebe der Größe **P4Q** mit synthetischem Öl befüllt. Bei Einbaulage V5 oder V6 bitten wir um Rücksprache. In Tabelle 1 ist die Schmiermenge und das empfohlene Schmiermittel angegeben. In Tabelle 2 sind die zulässigen Radial- und Axialbelastungen des Getriebes aufgeführt.

F Le réducteur de type **P4Q** est fourni lubrifié à vie avec de l'huile synthétique. Concernant les positions V5.V6, contactez notre service d'assistance technique. Voir tableau 1 concernant les huiles et les quantités conseillées. Les charges radiales et axiales applicables au réducteur sont précisées dans le tableau 2.

E El reductor tamaño **P4Q** se suministra, lubricado de por vida con aceite sintético. Para las posiciones V5 y V6 contactar con nuestro servicio técnico. Ver tabla 1, para cantidades y aceites recomendados. En la tabla 2, se encuentran las cargas radiales y axiales admitidas por el reductor.

LUBRICATION P4Q Oil
Common lubrication 0.17 l (A + B).

AGIP Telium VSF 320	SHELL Omala S4 WE 320
----------------------------	------------------------------

For all details on lubrication and plugs check our website **tab. 1**
Per maggiori dettagli su lubrificazione e tappi olio vedi il nostro sito web

RADIAL AND AXIAL LOADS

Output shaft
Albero di uscita

n_2 [min ⁻¹]	FA [N]	FR [N]
75	240	1200
50	260	1400
25	300	1800
15-6	400	2000

Input shaft
albero in entrata

n_1 [min ⁻¹]	FA [N]	FR [N]
1400	44	220

*Strong axial loads in the DX direction are not allowed.
Non sono consentiti forti carichi assiali con direzione DX

tab. 2

PP4QFB... Basic wormbox
Riduttore base

M. flanges	Kit code	øF	A
56B5	K050.4.046	120	143.5
63B5	K050.4.041	138	145.5
71B5	K050.4.042	160	143
63B14	K050.4.047	90	145.5
71B14	K050.4.045	105	143

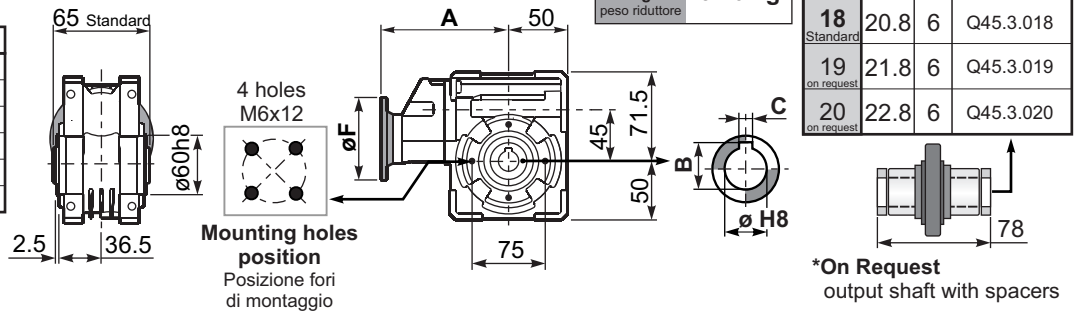

PP4QFC... Square flange
Flangia quadrata

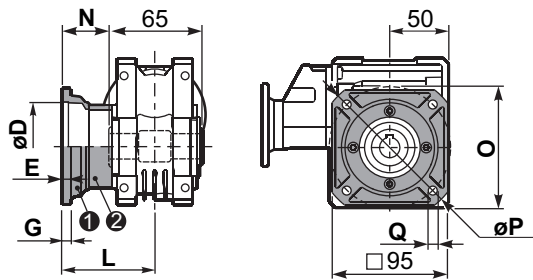

type B	øD	E	G	L	N	O	P	Q	kit code
FC	60 H8	4	7	67	34.5	75	110	9	KQ45.9.010
FL	60 H8	4	7	97	64.5	75	110	9	KQ45.9.011

PP4QF1... Round flange
Flangia rotonda

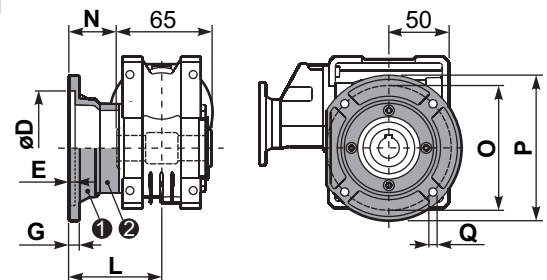

type S	øD	E	G	L	N	O	P	Q	kit code
F1	95H8	5	9	80	47.5	115	140	9.5	KSQ45.9.012
F2	80H8	5	12	58	25.5	100	120	9	KSQ45.9.013

PP4QFB... Feet
Piedini

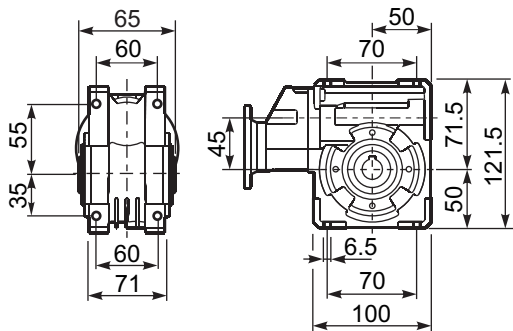

PP4QBR... Reaction arm
Braccio di reazione

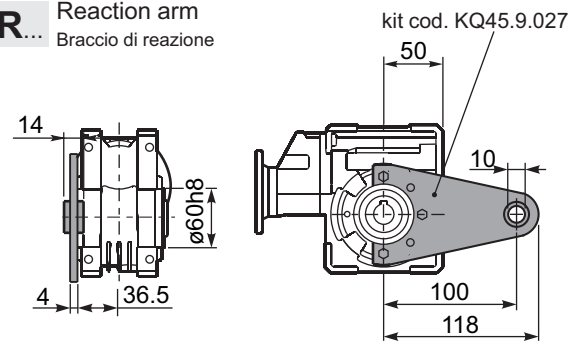

RP4QFB... Input shaft
Albero in entrata

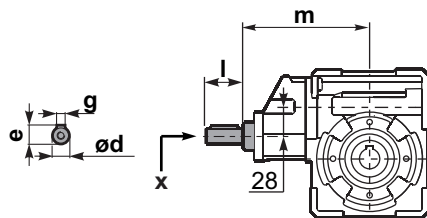

	ød	e	g	l	m	x	
type B	14 h6	16	5	25	141	M5x13	C35.5.061
type S	-	-	-	-	-	-	

PP4Q.....S... Single Shaft
Albero lento semplice

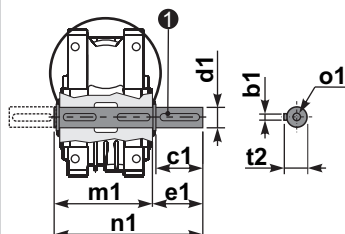

① kit cod. K045.5.028 type B
kit cod. KS045.5.030 type S

PP4Q.....D... Double Shaft
Albero lento bisp.

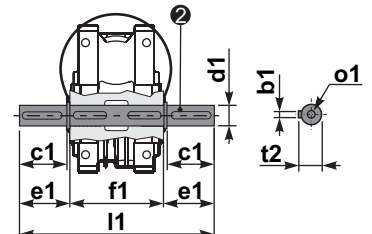

② kit cod. K045.5.029 type B
kit cod. KS045.5.031 type S

	b1	c1	d1	e1	f1	l1	m1	n1	t2	o1
type B	6	32	18 ^{-0.005} -0.020	43	65	151	70	113	20.5	M6x18
type S	6	40	19 ^{-0.005} -0.020	58.5	65	182	70	128.5	21.5	M8x20

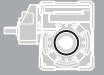

QUICK SELECTION / Selezione veloce

input speed (n_1) = 1400 min⁻¹

Output Speed n_2 [min ⁻¹]	Ratio i	Motor power P_{1M} [kW]	Output torque M_{2M} [Nm]	Service factor f.s.	Nominal power P_{1R} [kW]	Nominal torque M_{2R} [Nm]	Available B5 motor flanges			Available B14 motor flanges		Dynamic efficiency RD	Tooth Module [mm]	Ratios code
							A	B	C	P	Q			
							56	63	71	63	71			
47	30.1	0.37	58	1.3	0.49	77				C		76	2.5	01
33	43.0	0.25	55	1.4	0.35	77				C		75	2.4	02
23	60.2	0.25	71	1.1	0.27	77				C		69	2.6	03
18.1	77.4	0.25	81	1.1	0.27	88				C		61	2.0	04
12.5	112	0.18	84	1.1	0.19	88				C		61	2.7	05
9.0	155	0.12	71	1.2	0.15	88				C		56	2.1	06
7.6	185	0.12	74	1.0	0.12	77				C		49	1.8	07
5.4	258	0.12*	77	<0.8	0.09	77				C		47	1.3	08
4.8	292	0.12*	66	<0.8	0.08	66				C		44	1.2	09
4.1	344	0.12*	44	<0.8	0.05	44				C		40	1.0	10
3.3	430	0.12*	44	<0.8	0.04	44				C		36	0.8	11

A) Motor Flanges Available
Flange Motore Disponibili

B) Supplied with Reduction Bushing
Fornito con Bussola di Riduzione

B) Available on Request without reduction bushing
Disponibile a Richiesta senza Bussola di Riduzione

C) Motor Flange Holes Position
Posizione Fori Flangia Motore

* Power higher than the maximum one which can be supported by the gearbox. Select according to the torque M_{2R}
Potenza superiore a quella massima sopportabile dal riduttore. Selezionare in base al momento torcente M_{2R}

EN Unit **P5Q** is supplied with synthetic oil, providing "long life" lubrication. For mounting position V5-V6 please contact us. See table 1 for lubrication and recommended quantity. In table 2 please see possible radial loads and axial loads on the gearbox.

I Il riduttore tipo **P5Q** viene fornito lubrificato a vita con olio sintetico. Per posizioni V5-V6 contattare il ns. servizio tecnico. Vedi tab.1 per oli e quantità consigliati. In tab.2 sono presenti i carichi radiali e assiali applicabili al riduttore.

D Für die Lebensdauerschmierung ist das Getriebe der Größe **P5Q** mit synthetischem Öl befüllt. Bei Einbaulage V5 oder V6 bitten wir um Rücksprache. In Tabelle 1 ist die Schmiermenge und das empfohlene Schmiermittel angegeben. In Tabelle 2 sind die zulässigen Radial- und Axialbelastungen des Getriebes aufgeführt.

F Le réducteur de type **P5Q** est fourni lubrifié à vie avec de l'huile synthétique. Concernant les positions V5.V6, contactez notre service d'assistance technique. Voir tableau 1 concernant les huiles et les quantités conseillées. Les charges radiales et axiales applicables au réducteur sont précisées dans le tableau 2.

E El reductor tamaño **P5Q** se suministra, lubricado de por vida con aceite sintético. Para las posiciones V5 y V6 contactar con nuestro servicio técnico. Ver tabla 1, para cantidades y aceites recomendados. En la tabla 2, se encuentran las cargas radiales y axiales admitidas por el reductor.

LUBRICATION P5Q Oil
Common lubrication 0.26 l (A + B).

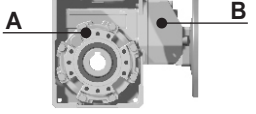

AGIP Telium VSF 320	SHELL Omala S4 WE 320
----------------------------	------------------------------

For all details on lubrication and plugs check our website **tab. 1**
Per maggiori dettagli su lubrificazione e tappi olio vedi il nostro sito web

RADIAL AND AXIAL LOADS

Output shaft
Albero di uscita

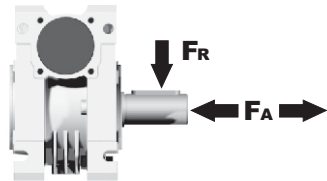

n_2 [min ⁻¹]	FA [N]	FR [N]
75	340	1700
50	380	1900
25	480	2500
15-6	560	2800

Input shaft
albero in entrata

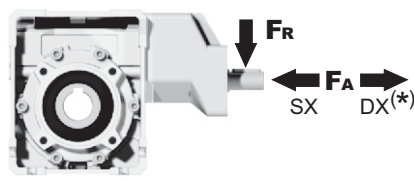

n_1 [min ⁻¹]	FA [N]	FR [N]
1400	44	220

*Strong axial loads in the DX direction are not allowed.
Non sono consentiti forti carichi assiali con direzione DX

tab. 2

PP5QFB... Basic wormbox
Riduttore base

M. flanges	Kit code	øF	A
56B5	K050.4.046	120	147
63B5	K050.4.041	138	149
71B5	K050.4.042	160	146.5
63B14	K050.4.047	90	149
71B14	K050.4.045	105	146.5

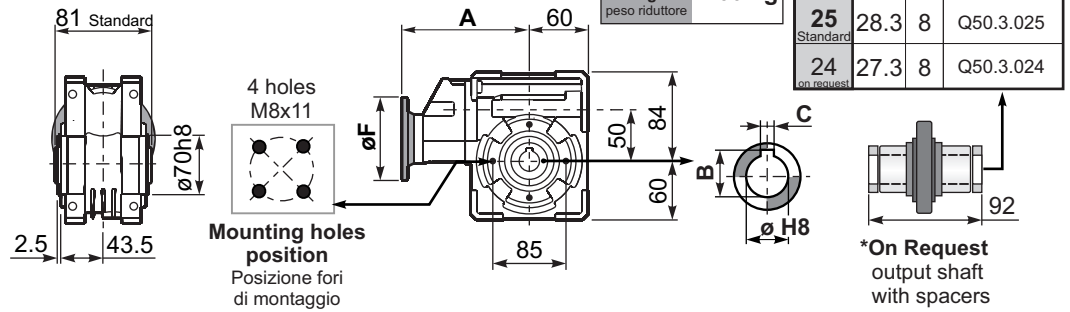

PP5QFC... Square flange
Flangia quadrata

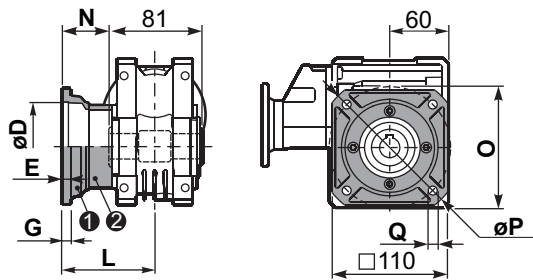

type B	øD	E	G	L	N	O	P	Q	kit code
FC	70 H8	5	9	90	49.5	85	125	11	KQ50.9.010
FL	70 H8	5	9	120	79.5	85	125	11	KQ50.9.011

PP5QF1... Round flange
Flangia rotonda

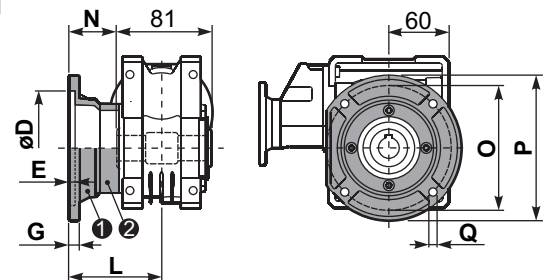

type S	øD	E	G	L	N	O	P	Q	kit code
F1	110 H8	5	10	89	69.5	130	160	9.5	KSQ50.9.012
F2	95 H8	5	14.5	72	31.5	115	140	11	KSQ50.9.013

PP5QFB... Feet
Piedini

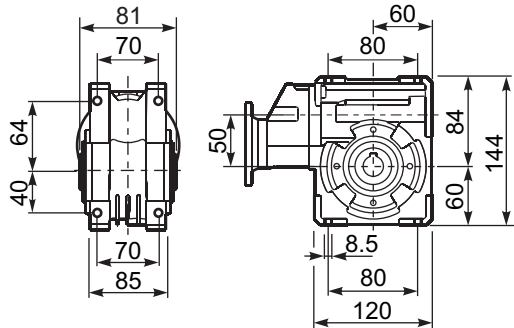

PP5QBR... Reaction arm
Braccio di reazione

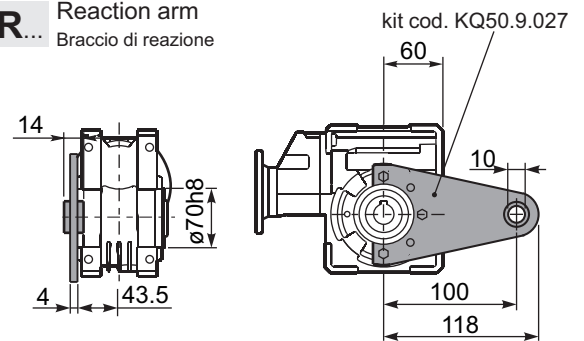

RP5QFB... Input shaft
Albero in entrata

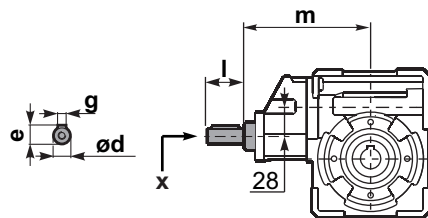

	ød	e	g	l	m	x	
type B	14 h6	16	5	25	140.5	M5x13	C35.5.061
type S	-	-	-	-	-	-	

PP5Q.....S... Single Shaft
Albero lento semplice

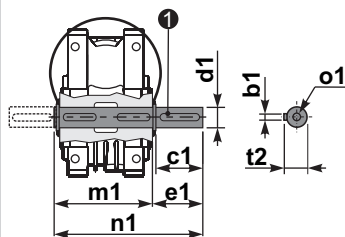

① kit cod. K050.5.028 type B
kit cod. KS050.5.030 type S

PP5Q.....D... Double Shaft
Albero lento bisp.

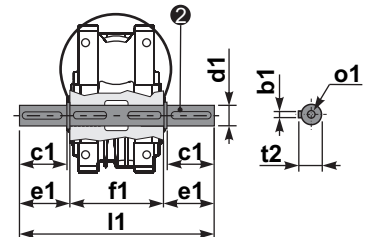

② kit cod. K050.5.029 type B
kit cod. KS050.5.031 type S

	b1	c1	d1	e1	f1	l1	m1	n1	t2	o1
type B	8	52	25 ^{-0.005} _{-0.020}	59.5	81	200	86.5	146	28	M8x20
type S	8	50	24 ^{-0.005} _{-0.020}	68.8	81	218	86.5	155	27	M8x20

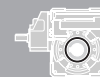

QUICK SELECTION / Selezione veloce

input speed (n_1) = 1400 min⁻¹

	Output Speed n_2 [min ⁻¹]	Ratio i	Motor power P_{1M} [kW]	Output torque M_{2M} [Nm]	Service factor f.s.	Nominal power P_{1R} [kW]	Nominal torque M_{2R} [Nm]	Available B5 motor flanges				Available B14 motor flanges				Dynamic efficiency RD	Tooth Module [mm]	Ratios code
								B	C	D	E	P	Q	R	T			
								63	71	80	90	63	71	80	90			
IEC 90 - 80 - 71	47	29.9	0.75	113	1.5	1.1	165						C	C		74	2.6	01
	37	37.7	0.75	141	1.2	0.88	165						C	C		73	2.0	02
	30	47.1	0.75	169	1.1	0.83	187						C	C		70	3.2	03
	25	56.6	0.55	136	1.4	0.76	187						C	C		64	2.7	04
	19.8	70.7	0.55	164	1.1	0.63	187						C	C		62	2.1	05
	15.9	87.8	0.37	162	1.2	0.43	187						C	C		73	2.6	06
	12.6	111.0	0.37	199	0.9	0.35	187						C	C		71	2.0	07
IEC 71 - 63	10.1	139	0.37	234	0.8	0.30	187						C			67	3.2	08
	8.4	166	0.25	173	1.1	0.27	187						C			61	2.7	09
	6.7	208	0.18	151	1.1	0.20	165						C			59	2.1	10
	4.5	310	0.12	129	1.3	0.15	165						C			51	1.5	11
	3.8	370	0.12	145	1.1	0.14	165						C			48	1.3	12
	3.2	434	0.12	149	0.9	0.11	138						C			42	1.1	13

A) Motor Flanges Available
Flange Motore Disponibili

B) Supplied with Reduction Bushing
Fornito con Bussola di Riduzione

B) Available on Request without reduction bushing
Disponibile a Richiesta senza Bussola di Riduzione

C) Motor Flange Holes Position
Posizione Fori Flangia Motore

EN Unit **P6Q** is supplied with synthetic oil, providing "long life" lubrication. For mounting position V5-V6 please contact us. See table 1 for lubrication and recommended quantity. In table 2 please see possible radial loads and axial loads on the gearbox.

I Il riduttore tipo **P6Q** viene fornito lubrificato a vita con olio sintetico. Per posizioni V5-V6 contattare il ns. servizio tecnico. Vedi tab.1 per oli e quantità consigliati. In tab.2 sono presenti i carichi radiali e assiali applicabili al riduttore.

D Für die Lebensdauerschmierung ist das Getriebe der Größe **P6Q** mit synthetischem Öl befüllt. Bei Einbaulage V5 oder V6 bitten wir um Rücksprache. In Tabelle 1 ist die Schmiermenge und das empfohlene Schmiermittel angegeben. In Tabelle 2 sind die zulässigen Radial- und Axialbelastungen des Getriebes aufgeführt.

F Le réducteur de type **P6Q** est fourni lubrifié à vie avec de l'huile synthétique. Concernant les positions V5.V6, contactez notre service d'assistance technique. Voir tableau 1 concernant les huiles et les quantités conseillées. Les charges radiales et axiales applicables au réducteur sont précisées dans le tableau 2.

E El reductor tamaño **P6Q** se suministra, lubricado de por vida con aceite sintético. Para las posiciones V5 y V6 contactar con nuestro servicio técnico. Ver tabla 1, para cantidades y aceites recomendados. En la tabla 2, se encuentran las cargas radiales y axiales admitidas por el reductor.

LUBRICATION P6Q Oil

For B3-V5-V6 separate lubrication for A (0.30 l) B (0.08 l), for B6-B7-B8 common lubrication 0.35 l (A + B).

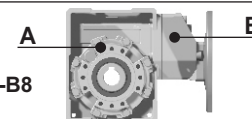

AGIP Telium VSF 320

SHELL Omala S4 WE 320

For all details on lubrication and plugs check our website **tab. 1**
Per maggiori dettagli su lubrificazione e tappi olio vedi il nostro sito web

RADIAL AND AXIAL LOADS

Output shaft

Albero di uscita

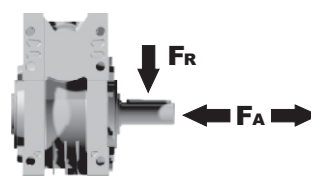

n_2 [min ⁻¹]	FA [N]	FR [N]
75	500	2500
50	600	3000
25	700	3800
15-6	800	4000

Input shaft

albero in entrata

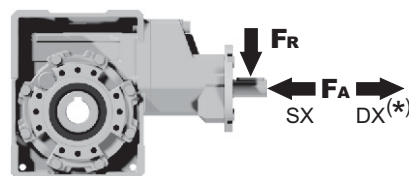

n_1 [min ⁻¹]	FA [N]	FR [N]
1400	61	305

*Strong axial loads in the DX direction are not allowed.
Non sono consentiti forti carichi assiali con direzione DX

tab. 2

PP6QFB... Basic wormbox
Riduttore base

Gearbox weight	29.9+111	139+434
peso riduttore	7.05	6.60
	Kg	Kg

M.flange	Kit code	øF	A
71B5	K063.4.042	160	176.5
80/90B5	K063.4.043	200	178.5
71B14	K063.4.047	105	176.5
80B14	K063.4.046	120	178.5
90B14	K063.4.041	140	178.5
<hr/>			
63B5	K050.4.041	138	162.5
71B5	K050.4.042	160	160
63B14	K050.4.047	90	162.5
71B14	K050.4.045	105	160

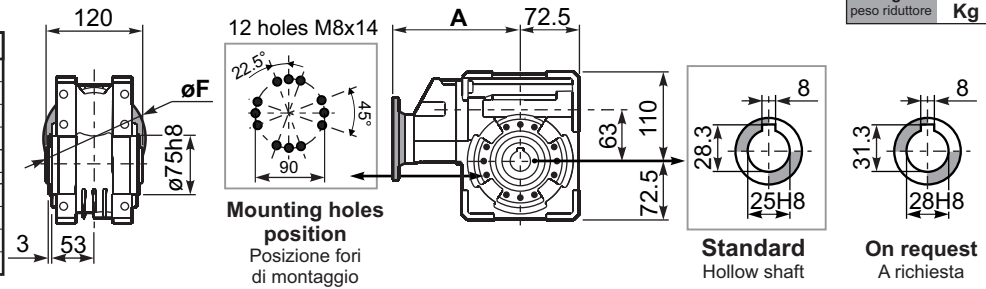

PP6QFC... Output flange
Flangia uscita

PP6QF1... Output flange
Flangia uscita

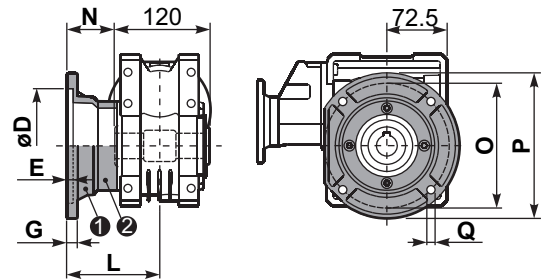
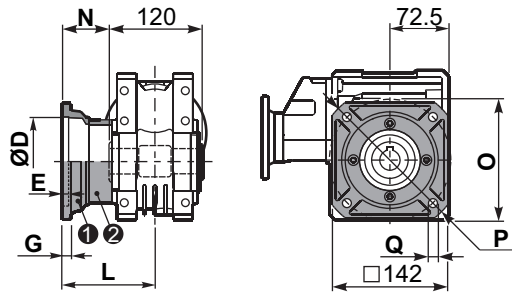

type B	øD	E	G	L	N	O	P	Q	kit code
FC	115 ^{+0.20} / _{+0.15}	6	12	86	26	150	180	11	1 KQ63.9.010 2 -
FL	115 ^{+0.20} / _{+0.15}	6	12	116	56	150	180	11	1 KQ63.9.010 2 K063.0.200

type S	øD	E	G	L	N	O	P	Q	kit code
F1	130 ^{+0.20} / _{+0.15}	7	13	110	50	165	200	13	1 KS070.9.013 2 -
F2	115 ^{+0.20} / _{+0.15}	7	13	124	64	150	175	11	1 KS063.9.013 2 -
F3	110 ^{+0.035} / ₀	5	11	90	30	130	160	10	1 KS063.9.011 2 -

PP6QFB... Feet
Piedini

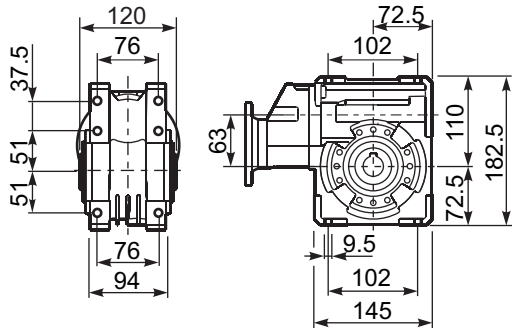

PP6QBR... Reaction arm
Braccio di reazione

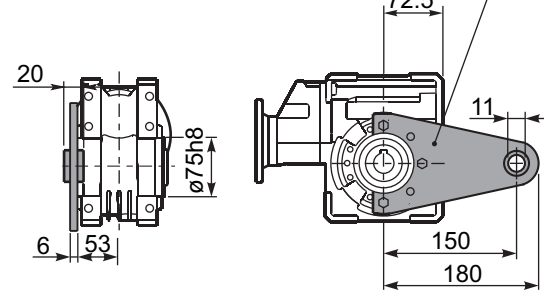

RP6QFB... Input shaft
Albero in entrata

PP6Q.....S... Single Shaft
Albero lento semplice

PP6Q.....D... Double Shaft
Albero lento bisp.

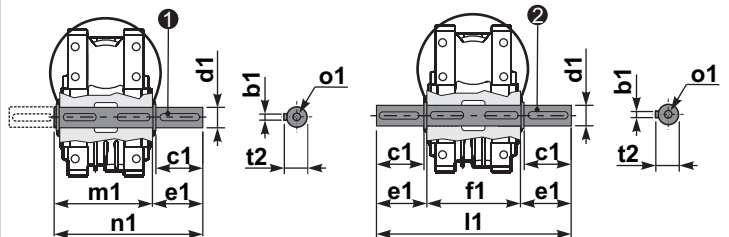
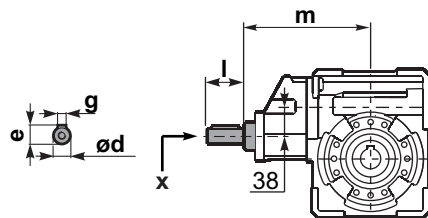

1 kit cod. K063.5.028 type B 2 kit cod. K063.5.029 type B

	ød	e	g	l	m	x	
29.9+111	19 h6	21.5	6	35	169.4	M6x16	C40.5.062
139+434	14 h6	16	5	25	154.2	M5x13	C35.5.061

	b1	c1	d1	e1	f1	l1	m1	n1	t2	o1
type B	8	60	25 ^{-0.005} / _{-0.020}	63.2	120	246.4	126.8	190	28	M8x20
type S	-	-	-	-	-	-	-	-	-	-

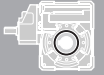

QUICK SELECTION / Selezione veloce

input speed (n₁) = 1400 min⁻¹

Output Speed n ₂ [min ⁻¹]	Ratio i	Motor power P _{1M} [kW]	Output torque M _{2M} [Nm]	Service factor f.s.	Nominal power P _{1R} [kW]	Nominal torque M _{2R} [Nm]	Available B5 motor flanges				Available B14 motor flanges			Dynamic efficiency RD	Tooth Module [mm]	Ratios code
							B	C	D	E	Q	R	T			
							63	71	80	90	71	80	90			
22	62.9	0.75	248	1.2	0.87	286					C	C		77	3.10	01
18	78.5	0.75	293	1.0	0.73	286					C	C		73	2.41	02
15	94.2	0.75	333	0.9	0.70	310					C	C		69	2.10	03
11	126	0.55	297	1.0	0.55	296	B				C	C		63	1.53	04
9	157	0.37	230	1.1	0.41	252	B				C	C		58	1.23	05
8	185	0.37	257	1.2	0.43	296	B				C	C		55	3.10	06
6	231	0.25	193	1.5	0.38	296	B				C	C		49	2.41	07
5	277	0.25	222	1.3	0.33	296	B				C	C		47	2.10	08
4	378	0.18	200	1.5	0.27	296	B				C	C		43	2.10	09

A) Motor Flanges Available
Flange Motore Disponibili

B) Supplied with Reduction Bushing
Fornito con Bussola di Riduzione

B) Available on Request without reduction bushing
Disponibile a Richiesta senza Bussola di Riduzione

C) Motor Flange Holes Position
Posizione Fori Flangia Motore

* Power higher than the maximum one which can be supported by the gearbox. Select according to the torque M_{2R}
Potenza superiore a quella massima sopportabile dal riduttore. Selezionare in base al momento torcente M_{2R}

EN Unit P7Q is supplied with synthetic oil, providing "long life" lubrication. For mounting position V5-V6 please contact us. See table 1 for lubrication and recommended quantity. In table 2 please see possible radial loads and axial loads on the gearbox.

I Il riduttore tipo P7Q viene fornito lubrificato a vita con olio sintetico. Per posizioni V5-V6 contattare il ns. servizio tecnico. Vedi tab.1 per oli e quantità consigliati. In tab.2 sono presenti i carichi radiali e assiali applicabili al riduttore.

D Für die Lebensdauerschmierung ist das Getriebe der Größe P7Q mit synthetischem Öl befüllt. Bei Einbaulage V5 oder V6 bitten wir um Rücksprache. In Tabelle 1 ist die Schmiermenge und das empfohlene Schmiermittel angegeben. In Tabelle 2 sind die zulässigen Radial- und Axialbelastungen des Getriebes aufgeführt.

F Le réducteur de type P7Q est fourni lubrifié à vie avec de l'huile synthétique. Concernant les positions V5.V6, contactez notre service d'assistance technique. Voir tableau 1 concernant les huiles et les quantités conseillées. Les charges radiales et axiales applicables au réducteur sont précisées dans le tableau 2.

E El reductor tamaño P7Q se suministra, lubricado de por vida con aceite sintético. Para las posiciones V5 y V6 contactar con nuestro servicio técnico. Ver tabla 1, para cantidades y aceites recomendados. En la tabla 2, se encuentran las cargas radiales y axiales admitidas por el reductor.

LUBRICATION P7Q Oil

For B3-V5-V6 separate lubrication for A (0.40 l) B (0.14 l), for B6-B7-B8 common lubrication 0.65 l (A + B).

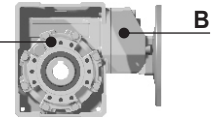

AGIP Telium VSF 320

SHELL Omala S4 WE 320

For all details on lubrication and plugs check our website **tab. 1**
Per maggiori dettagli su lubrificazione e tappi olio vedi il nostro sito web

RADIAL AND AXIAL LOADS

Output shaft

Albero di uscita

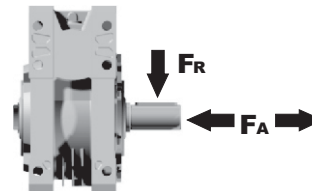

n ₂ [min ⁻¹]	FA [N]	FR [N]
75	620	3100
50	720	3600
25	880	4400
15-6	1000	5000

Input shaft

albero in entrata

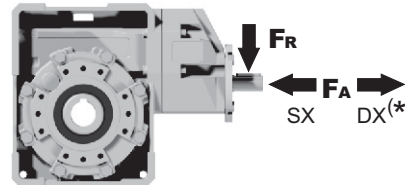

n [min ⁻¹]	FA [N]	FR [N]
1400	108	540

*Strong axial loads in the DX direction are not allowed.
Non sono consentiti forti carichi assiali con direzione DX

tab. 2

PP7Q**FB**... Basic wormbox
Riduttore base

Gearbox weight
peso riduttore **9.90 kg**

M. flanges	Kit code	øF	A
63B5	K063.4.041	140	192.7
71B5	K063.4.042	160	190.7
80/90B5	K063.4.043	200	192.7
71B14	K063.4.047	105	190.7
80B14	K063.4.046	120	192.7
90B14	K063.4.041	140	192.7

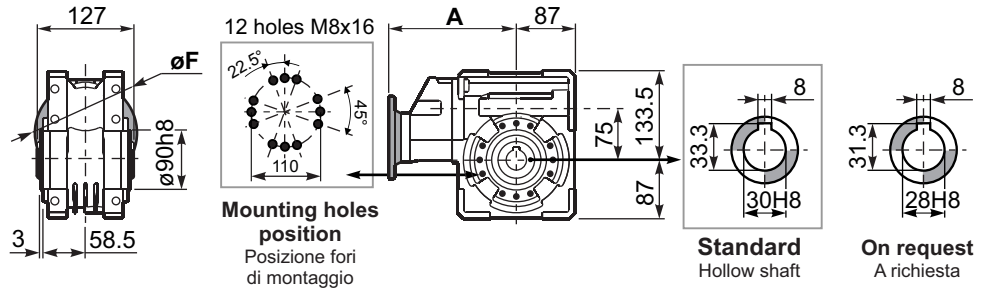

PP7Q**FC**... Square flange
Flangia quadrata

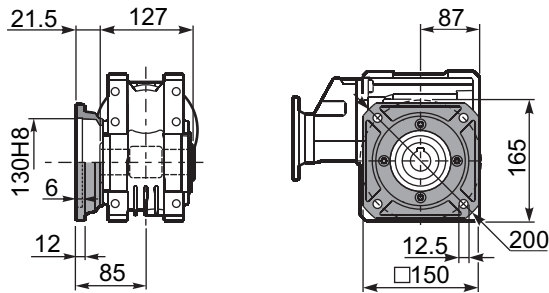

PP7Q**FL**... Square flange
Flangia quadrata

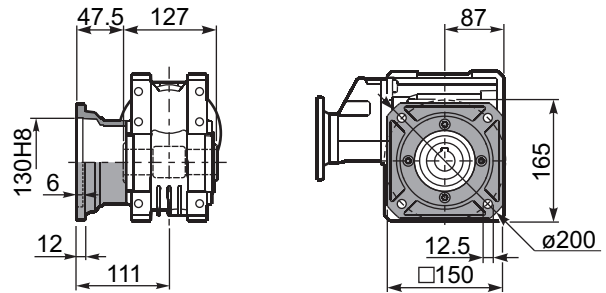

PP7Q**FB**... Feet
Piedini

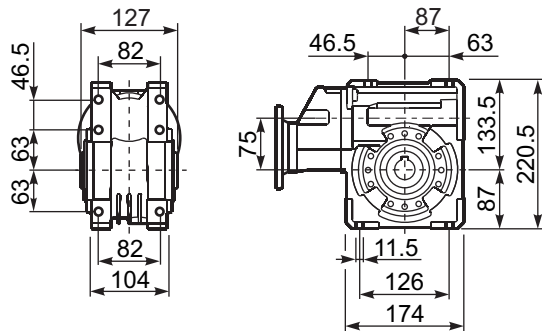

PP7Q**BR**... Reaction arm
Braccio di reazione

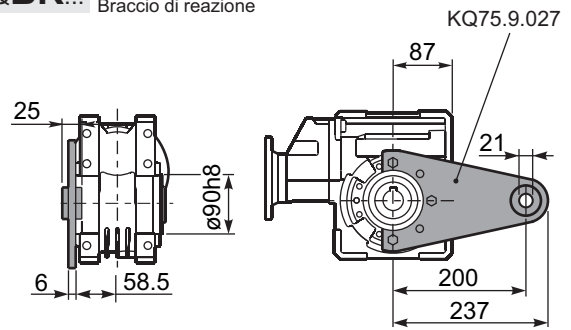

RP7Q**FB**... Input shaft
Albero in entrata

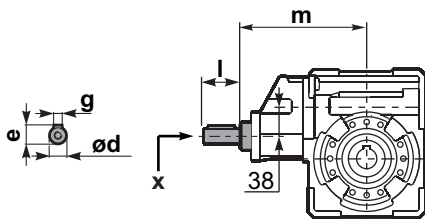

PP7Q.....**S**... Single Shaft
Albero lento semplice

PP7Q.....**D**... Double Shaft
Albero lento bisp.

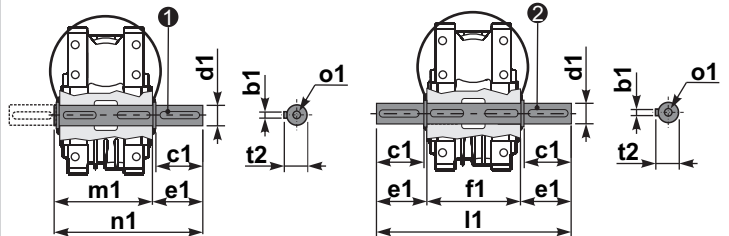

① kit cod. KQ75.5.028 Standard
kit cod. KQ75.5.026 On request

② kit cod. KQ75.5.029 Standard
kit cod. KQ75.5.027 On request

	ød	e	g	l	m	x	
type B	19 h6	21.5	6	35	185.5	M6x16	C40.5.062
type S	-	-	-	-	-	-	

	b1	c1	d1	e1	f1	l1	m1	n1	t2	o1
Standard	8	60	30 ^{-0.005} _{-0.020}	65	127	255	134	199	33	M8x20
On request	8	50	28 ^{-0.005} _{-0.020}	65	127	255	134	199	31	M8x20

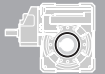

QUICK SELECTION / Selezione veloce

input speed (n_1) = 1400 min⁻¹

Output Speed n_2 [min ⁻¹]	Ratio i	Motor power P_{1M} [kW]	Output torque M_{2M} [Nm]	Service factor f.s.	Nominal power P_{1R} [kW]	Nominal torque M_{2R} [Nm]	Available B5 motor flanges				Available B14 motor flanges			Dynamic efficiency RD	Tooth Module [mm]	Ratios code
							B	C	D	E	Q	R	T			
							63	71	80	90	71	80	90			
23.5	59.7	1.1	300	1.4	1.5	418					C	C		67	3.5	01
19.4	72.3	1.1	347	1.2	1.3	407					C	C		64	3.1	02
17.1	81.7	1.1	374	1.1	1.2	418					C	C		61	2.7	03
13.3	105	0.75	323	1.2	0.89	385					C	C		60	2.1	04
8.0	176	0.55	415	1.1	0.58	440	B				C	C		63	3.5	05
6.6	213	0.37	322	1.3	0.47	407	B				C	C		60	3.1	06
5.8	240	0.37	321	1.3	0.48	418	B				C	C		53	2.7	07
4.3	328	0.37	438	1.0	0.35	418	B				C	C		53	2.7	08
3.3	422	0.25	374	1.0	0.26	385	B				C	C		52	2.1	09
3.0	466	0.25	358	0.9	0.23	330	B				C	C		45	1.9	10
2.3	605	0.18	297	1.1	0.20	330	B				C	C		40	1.5	11

Motor Flanges Available
Flange Motore Disponibili

B) Supplied with Reduction Bushing
Fornito con Bussola di Riduzione

B) Available on Request without reduction bushing
Disponibile a Richiesta senza Bussola di Riduzione

C) Motor Flange Holes Position
Posizione Fori Flangia Motore

EN Unit **P8Q** is supplied with synthetic oil, providing "long life" lubrication. For mounting position V5-V6 please contact us. See table 1 for lubrication and recommended quantity. In table 2 please see possible radial loads and axial loads on the gearbox.

I Il riduttore tipo **P8Q** viene fornito lubrificato a vita con olio sintetico. Per posizioni V5-V6 contattare il ns. servizio tecnico. Vedi tab.1 per oli e quantità consigliati. In tab.2 sono presenti i carichi radiali e assiali applicabili al riduttore.

D Für die Lebensdauerschmierung ist das Getriebe der Größe **P8Q** mit synthetischem Öl befüllt. Bei Einbaulage V5 oder V6 bitten wir um Rücksprache. In Tabelle 1 ist die Schmiermenge und das empfohlene Schmiermittel angegeben. In Tabelle 2 sind die zulässigen Radial- und Axialbelastungen des Getriebes aufgeführt.

F Le réducteur de type **P8Q** est fourni lubrifié à vie avec de l'huile synthétique. Concernant les positions V5.V6, contactez notre service d'assistance technique. Voir tableau 1 concernant les huiles et les quantités conseillées. Les charges radiales et axiales applicables au réducteur sont précisées dans le tableau 2.

E El reductor tamaño **P8Q** se suministra, lubricado de por vida con aceite sintético. Para las posiciones V5 y V6 contactar con nuestro servicio técnico. Ver tabla 1, para cantidades y aceites recomendados. En la tabla 2, se encuentran las cargas radiales y axiales admitidas por el reductor.

LUBRICATION P8Q Oil

For B3-V5-V6 separate lubrication for A (1.20 l) B (0.14 l) , for B6-B7-B8 common lubrication 1.00 l (A + B).

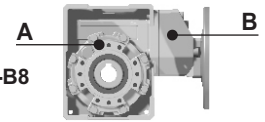

AGIP Telium VSF 320

SHELL Omala S4 WE 320

For all details on lubrication and plugs check our website **tab. 1**
Per maggiori dettagli su lubrificazione e tappi olio vedi il nostro sito web

RADIAL AND AXIAL LOADS

Output shaft

Albero di uscita

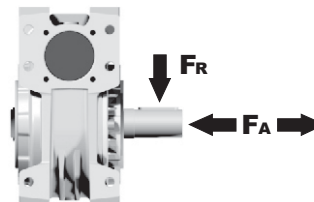

n_2 [min ⁻¹]	FA [N]	FR [N]
75	700	3500
50	800	4000
25	1000	5000
15-6	1160	5800

Input shaft

albero in entrata

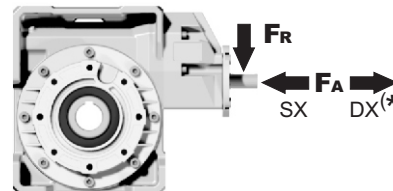

n_1 [min ⁻¹]	FA [N]	FR [N]
1400	108	540

*Strong axial loads in the DX direction are not allowed.
Non sono consentiti forti carichi assiali con direzione DX

tab. 2

PP8QFB... Basic wormbox
Riduttore base

Gearbox weight
peso riduttore **12.3 kg**

M. flanges	Kit code	øF	A
63B5	K063.4.041	140	195.2
71B5	K063.4.042	160	193.2
80/90B5	K063.4.043	200	195.2
71B14	K063.4.047	105	193.2
80B14	K063.4.046	120	195.2
90B14	K063.4.041	140	195.2

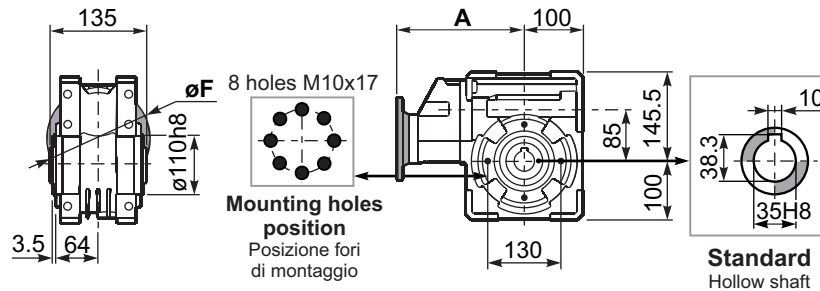

Standard
Hollow shaft

PP8QFC... Output flange
Flangia uscita

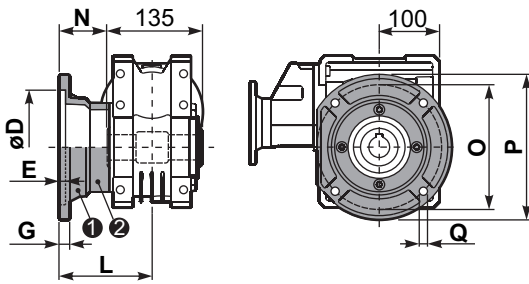

type B	øD	E	G	L	N	O	P	Q	kit code
FC	152 ^{+0.06} / _{+0.00}	5	16	108	40.5	176	205	13	① K085.9.010 ② -
FL	152 ^{+0.06} / _{+0.00}	5	16	148.5	81	176	205	13	① K085.9.010 ② K085.0.201

PP8QF1... Output flange
Flangia uscita

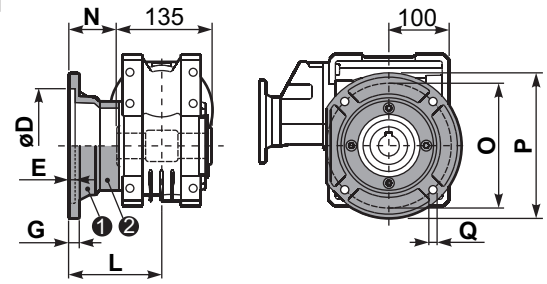

type S	øD	E	G	L	N	O	P	Q	kit code
F1	130 ^{+0.04} / _{+0.00}	5	13	117.5	50	165	200	11.5	① KS085.9.012 ② -
F2	152 ^{+0.06} / _{+0.00}	5	15	147.5	80	180	205	12.5	① KS085.9.013 ② -
F4	130 ^{+0.04} / _{+0.00}	5	13	106.5	39	165	200	13	① KS085.9.015 ② -

PP8QFB... Feet
Piedini

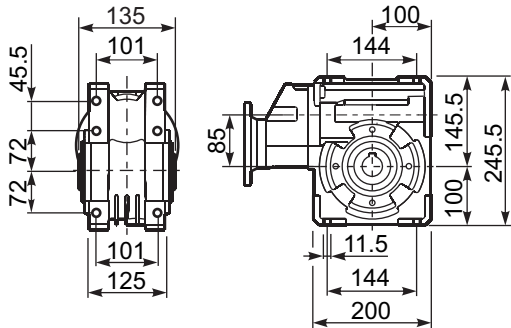

PP8QBR... Reaction arm
Braccio di reazione

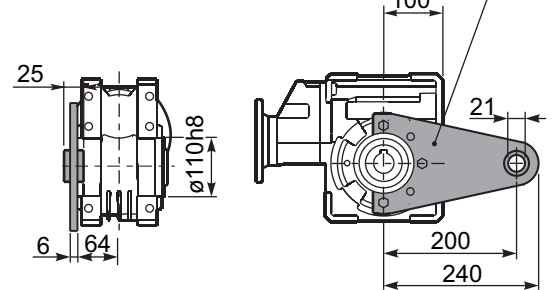

RP8QFB... Input shaft
Albero in entrata

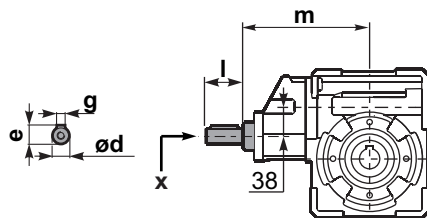

	ød	e	g	l	m	x	
type B	19 h6	21.5	6	35	187.5	M6x16	C40.5.062
type S	-	-	-	-	-	-	-

PP8Q.....S... Single Shaft
Albero lento semplice

PP8Q.....D... Double Shaft
Albero lento bisp.

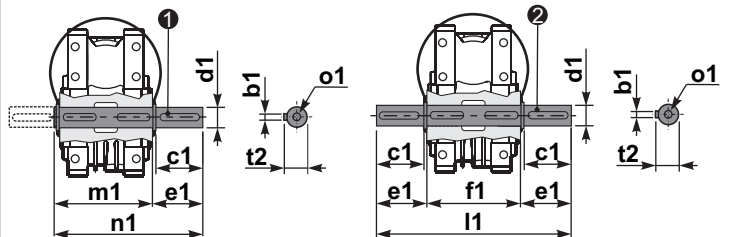

① kit cod. K085.5.028 type B ② kit cod. K085.5.029 type B

	b1	c1	d1	e1	f1	l1	m1	n1	t2	o1
type B	10	60	35 ^{-0.005} / _{-0.020}	73.5	135	282	141	214.5	38	M10x23
type S	-	-	-	-	-	-	-	-	-	-

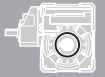

QUICK SELECTION / Selezione veloce

input speed (n_1) = 1400 min⁻¹

Output Speed n_2 [min ⁻¹]	Ratio i	Motor power P_{1M} [kW]	Output torque M_{2M} [Nm]	Service factor f.s.	Nominal power P_{1R} [kW]	Nominal torque M_{2R} [Nm]	Available B5 motor flanges				Available B14 motor flanges			Dynamic efficiency RD	Tooth Module [mm]	Ratios code
							B	C	D	E	Q	R	T			
							63	71	80	90	71	80	90			
16.8	83.2	1.5	587	1.1	1.7	660					C			69	3.5	01
13.9	100.5	1.5	699	0.8	1.3	594					C			68	2.9	02
10.6	132	1.1	634	0.9	0.95	550					C			64	2.2	03
8.0	176	0.75	666	1.2	0.90	803	B				C			74	4.7	04
6.7	208	0.75	766	0.9	0.65	660	B				C			72	4.0	05
5.7	245	0.55	634	1.0	0.57	660	B				C			69	3.5	06
4.7	296	0.55	755	0.8	0.43	594	B				C			68	2.9	07
4.2	334	0.55	865	0.8	0.42	660	B				C			69	3.5	08
3.5	403	0.37	692	0.9	0.32	594	B				C			68	2.9	09
2.6	529	0.25	577	1.0	0.24	550	B				C			64	2.2	10
2.2	624	0.25	628	0.8	0.21	528	B				C			59	1.9	11

Motor Flanges Available
Flange Motore Disponibili

B) Supplied with Reduction Bushing
Fornito con Bussola di Riduzione

B) Available on Request without reduction bushing
Disponibile a Richiesta senza Bussola di Riduzione

C) Motor Flange Holes Position
Posizione Fori Flangia Motore

EN Unit **P1Q** is supplied without lubricant and equipped with a breather, level and drain plugs. User can add mineral oil keeping existing plugs. Should the user wish to fill it with synthetic oil, it is recommended to replace the existing plugs with a closed plug. Primary reduction unit is supplied with closed plugs and lubricated for life with synthetic oil. See table 1 for lubrication and recommended quantity. In table 2 please see possible radial loads and axial loads on the gearbox.

I Il riduttore tipo **P1Q** è fornito privo di lubrificazione con tappi di sfiato, livello e scarico olio. L'utente può immettere olio minerale mantenendo i tappi esistenti. Se immetterà olio sintetico, dovrà sostituire i tappi esistenti con altri tipo chiuso. La precoppia è fornita con tappi chiusi e lubrificata a vita con olio sintetico. Tab.1 per oli e quantità consigliati. Tab.2 carichi radiali e assiali applicabili al riduttore.

D Das Getriebe der Baugröße **P1Q** wird ohne Schmiermittel geliefert. Es ist jedoch mit Einfüllschraube, Überdruckventil und Ablassschraube ausgerüstet. Das benötigte mineralische Öl kann über die Einfüllschraube eingefüllt werden. Sollte synthetisches Öl bevorzugt werden, so ist sind das eingebaute Überdruckventil durch eine geschlossenen Schraube zu ersetzen. Die Stirnradvorstufe ist Lebensdauer geschmiert und wird mit synthetischem Öl geliefert. Die Stirnradvorstufe ist komplett geschlossen ohne Füllschrauben. In Tabelle 1 ist die Schmiermenge und das empfohlene Schmiermittel angegeben. In Tabelle 2 sind die zulässigen Radial- und Axialbelastungen des Getriebes aufgeführt.

F Le réducteur de type **P1Q** est fourni sans lubrification et avec un bouchon de remplissage, de niveau et d'évacuation de l'huile. L'utilisateur peut y verser de l'huile minérale en conservant les bouchons existants. S'il y versera de l'huile synthétique, il devra substituer les bouchons existants avec d'autres bouchons de type fermé. Le pré couple est fourni lubrifié à vie avec de l'huile synthétique et avec des bouchons fermés. Voir tableau 1 concernant les huiles et les quantités conseillées. Voir tableau 2 concernant les charges radiales et axiales applicables au réducteur.

E El reductor tamaño **P1Q** se suministra sin lubricante, provisto de tapones de respiración, nivel y descarga de aceite. El usuario puede utilizar aceite mineral, manteniendo los tapones existentes. Si prefiere utilizar aceite sintético deberá sustituir los tapones existentes por tapones ciegos. La prerreducción se suministra con tapones ciegos, lubricado de por vida con aceite sintético. Ver tabla 1, para cantidades y aceites recomendados. En la tabla 2, se encuentran las cargas radiales y axiales admitidas por el reductor.

B3	B6	B7	B8	V5	V6
2.0/0.14LT	1.5/0.14 LT	1.5/0.14 LT	2.0/0.14 LT	2.0/0.14 LT	2.0/0.14 LT

AGIP Blasias 460

For all details on lubrication and plugs check our website [www.agip.com](#) **tab. 1**
Per maggiori dettagli su lubrificazione e tappi olio vedi il nostro sito web

RADIAL AND AXIAL LOADS

Output shaft

Albero di uscita

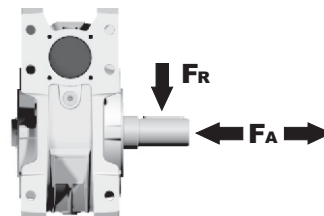

n_2 [min ⁻¹]	FA [N]	FR [N]
75	800	4000
50	920	4600
25	1200	6000
15-6	1400	7000

Input shaft

albero in entrata

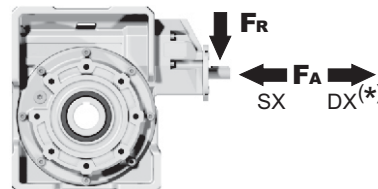

n_1 [min ⁻¹]	FA [N]	FR [N]
1400	150	760

***Strong axial loads in the DX direction are not allowed.**
Non sono consentiti forti carichi assiali con direzione DX

tab. 2

PP1QFB... Basic wormbox
Riduttore base

Gearbox weight
peso riduttore **37.3 kg**

M. flanges	Kit code	øF	A
63B5	K063.4.041	140	214.7
71B5	K063.4.042	160	212.7
80/90B5	K063.4.043	200	214.7
71B14	K063.4.047	105	212.7
80B14	K063.4.046	120	214.7
90B14	K063.4.041	140	214.7

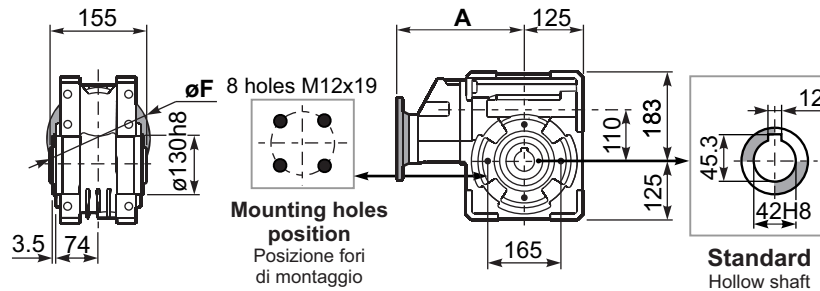

PP1QFC... Output flange
Flangia uscita

PP1QF1... Output flange
Flangia uscita

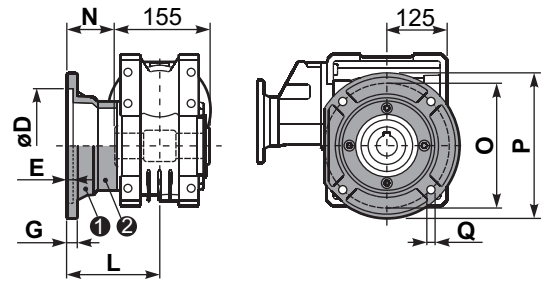
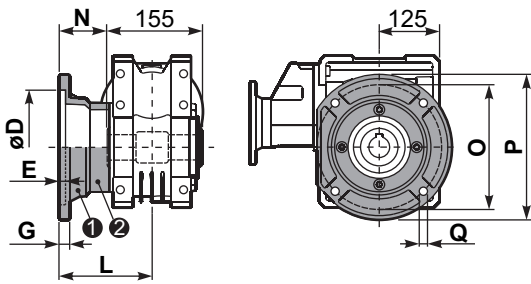

type B	øD	E	G	L	N	O	P	Q	kit code
FC	170 ^{+0.083} / _{+0.043}	11	16.5	131.5	54	230	270	13	1 K110.9.010 2 -
FL	170 ^{+0.083} / _{+0.043}	11	16.5	179.5	102	230	270	13	1 K110.9.011 2 -

type S	øD	E	G	L	N	O	P	Q	kit code
F1	180 ^{+0.040} / ₀	5	18	150	72.5	215	250	15	1 KS110.9.014 2 -
F2	170 ^{+0.083} / _{+0.043}	9.5	15	178	100.5	230	270	13	1 KS110.9.012 2 -
F3	180 ^{+0.040} / ₀	5	18	130	52.5	215	250	15	1 KS110.9.013 2 -

PP1QFB... Feet
Piedini

PP1QBR... Reaction arm
Braccio di reazione

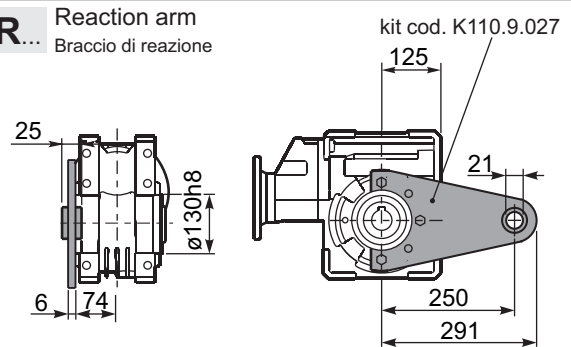
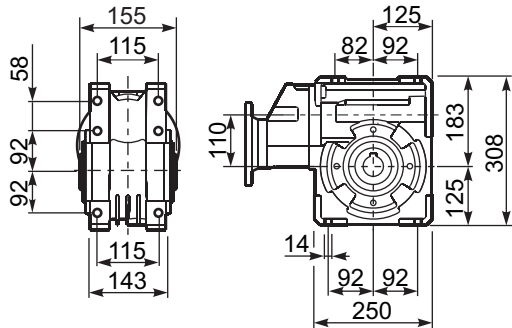

RP1QFB... Input shaft
Albero in entrata

PP1Q.....S... Single Shaft
Albero lento semplice

PP1Q.....D... Double Shaft
Albero lento bisp.

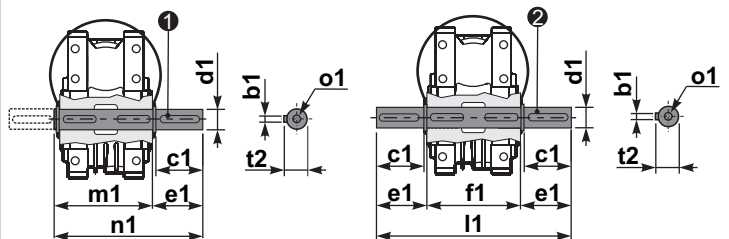
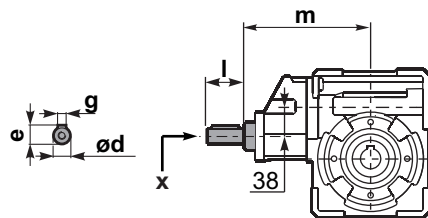

1 kit cod. K110.5.028 type B 2 kit cod. K110.5.029 type B

	ød	e	g	l	m	x	
type B	19 h6	21.5	6	35	205	M6x16	C40.5.062
type S	-	-	-	-	-	-	-

	b1	c1	d1	e1	f1	l1	m1	n1	t2	o1
type B	12	75	42 ^{-0.005} / _{-0.020}	96.5	155	348	163.5	260	45	M12x32
type S	-	-	-	-	-	-	-	-	-	-

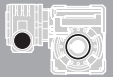

QUICK SELECTION / Selezione veloce							input speed (n ₁) = 1400 min ⁻¹						
Output Speed n ₂ [min ⁻¹]	Ratio i	Motor power P _{1M} [kW]	Output torque M _{2M} [Nm]	Service factor f.s.	Nominal power P _{1R} [kW]	Nominal torque M _{2R} [Nm]	Available B5 motor flanges		Available B14 motor flanges		Dynamic efficiency RD	Tooth Module [mm]	Ratios code
							A	B	O	P			
10.0	140	0.12	57	1.2	0.14	69	B		B-C		50	2.2	01
7.0	200	0.12	79	0.9	0.11	69	B		B-C		48	2.2	02
5.0	280	0.12*	69	<0.8	0.08	69	B		B-C		45	2.4	03
3.3	420	0.12*	69	<0.8	0.07	69	B		B-C		36	1.6	04
2.5	560	0.12*	69	<0.8	0.05	69	B		B-C		33	2.5	05
1.9	740	0.12*	69	<0.8	0.05	69	B		B-C		30	1.8	06
1.5	920	0.12*	69	<0.8	0.04	69	B		B-C		27	1.5	07
1.3	1120	0.12*	69	<0.8	0.03	69	B		B-C		26	2.5	08
0.9	1480	0.12*	69	<0.8	0.03	69	B		B-C		24	1.8	09
0.8	1840	0.12*	69	<0.8	0.02	69	B		B-C		22	1.5	10
0.6	2400	0.12*	69	<0.8	0.02	69	B		B-C		21	1.2	11

A Motor Flanges Available Flange Motore Disponibili
 B Supplied with Reduction Bushing Fornito con Bussola di Riduzione
 B Available on Request without reduction bushing Disponibile a Richiesta senza Bussola di Riduzione
 C Motor Flange Holes Position Posizione Fori Flangia Motore

* Power higher than the maximum one which can be supported by the gearbox. Select according to the torque M_{2R}
 Potenza superiore a quella massima sopportabile dal riduttore. Selezionare in base al momento torcente M_{2R}

EN Unit 43Q is supplied with synthetic oil, providing "long life" lubrication. For mounting position V5-V6 please contact us. See table 1 for lubrication and recommended quantity. In table 2 please see possible radial loads and axial loads on the gearbox.

I Il riduttore tipo 43Q viene fornito lubrificato a vita con olio sintetico. Per posizioni V5-V6 contattare il ns. servizio tecnico. Vedi tab.1 per oli e quantità consigliati. In tab.2 sono presenti i carichi radiali e assiali applicabili al riduttore.

D Für die Lebensdauerschmierung ist das Getriebe der Größe 43Q mit synthetischem Öl befüllt. Bei Einbaulage V5 oder V6 bitten wir um Rücksprache. In Tabelle 1 ist die Schmiermenge und das empfohlene Schmiermittel angegeben. In Tabelle 2 sind die zulässigen Radial- und Axialbelastungen des Getriebes aufgeführt.

F Le réducteur de type 43Q est fourni lubrifié à vie avec de l'huile synthétique. Concernant les positions V5.V6, contactez notre service d'assistance technique. Voir tableau 1 concernant les huiles et les quantités conseillées. Les charges radiales et axiales applicables au réducteur sont précisées dans le tableau 2.

E El reductor tamaño 43Q se suministra, lubricado de por vida con aceite sintético. Para las posiciones V5 y V6 contactar con nuestro servicio técnico. Ver tabla 1, para cantidades y aceites recomendados. En la tabla 2, se encuentran las cargas radiales y axiales admitidas por el reductor.

0.09 Lt. 0.03 Lt.

■ LUBRICATION 43Q Oil Quantity 0.09/0.03 Lt.

AGIP Telium VSF 320	SHELL Omala S4 WE 320
----------------------------	------------------------------

For all details on lubrication and plugs check our website **tab. 1**
 Per maggiori dettagli su lubrificazione e tappi olio vedi il nostro sito web

■ RADIAL AND AXIAL LOADS

Output shaft
Albero di uscita

n ₂ [min ⁻¹]	FA [N]	FR [N]
25	300	1800
15	400	2000

Input shaft
albero in entrata

n ₁ [min ⁻¹]	FA [N]	FR [N]
1400	20	100

***Strong axial loads in the DX direction are not allowed.**
 Non sono consentiti forti carichi assiali con direzione DX

tab. 2

P43QFB... Basic wormbox
Riduttore base

M. flanges	Kit code	øF	A
56B5	K030.4.041	120	61.5
63B5	K030.4.042	140	62.5
56B14	K030.4.046	80	61.5
63B14	K030.4.045	90	62.5

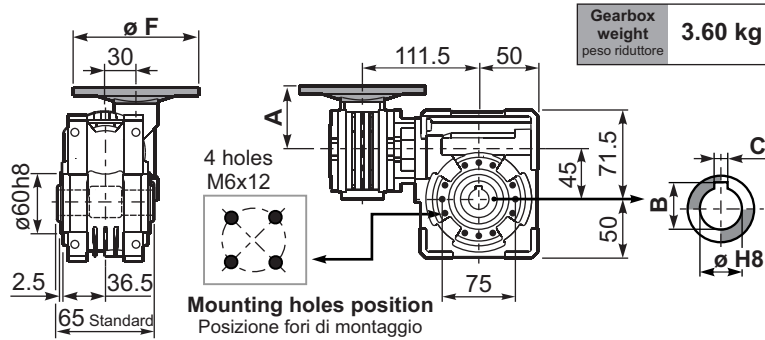

Gearbox weight
peso riduttore **3.60 kg**

ø H8	B	C	*Spacer code
18 Standard	20.8	6	Q45.3.018
19 on request	21.8	6	Q45.3.019
20 on request	22.8	6	Q45.3.020

*On Request
output shaft with spacers

P43QFC... Square flange
Flangia quadrata

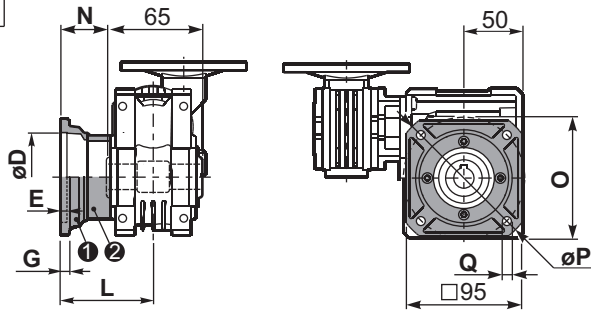

type B	øD	E	G	L	N	O	P	Q	kit code
FC	60 H8	4	7	67	34.5	75	110	9	KQ45.9.010
FL	60 H8	4	7	97	64.5	75	110	9	KQ45.9.011

P43QF1... Round flange
Flangia rotonda

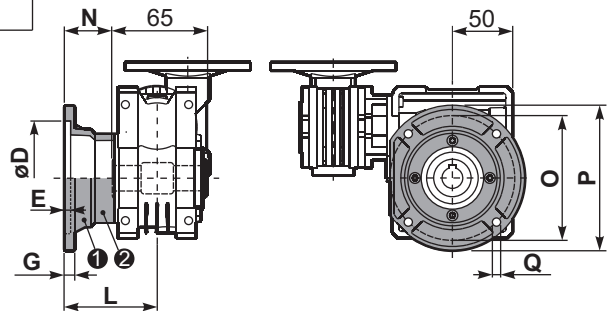

type S	øD	E	G	L	N	O	P	Q	kit code
F1	95H8	5	9	80	47.5	115	140	9.5	KSQ50.9.012
F2	80H8	5	12	58	25.5	100	120	9	KSQ50.9.013

P43QFB... Feet
Piedini

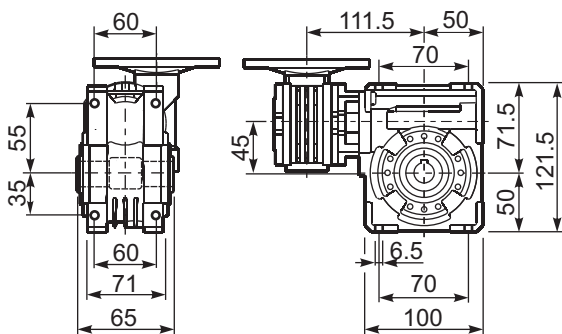

P43QBR... Reaction arm
Braccio di reazione

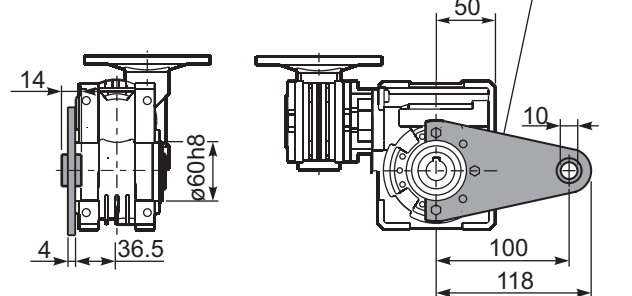

R43QFB... Input shaft
Albero in entrata

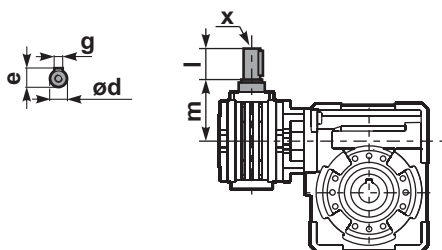

	ød	e	g	l	m	x	kit code
type B	9 h6	10.2	3	20	58	-	K030.5.006 PAM63
type S	-	-	-	-	-	-	-

P43Q.....S... Single Shaft
Albero lento semplice

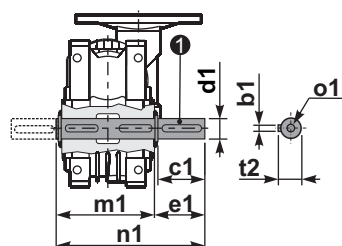

① kit cod. K045.5.028 type B
kit cod. KS045.5.030 type S

P43Q.....D... Double Shaft
Albero lento bisp.

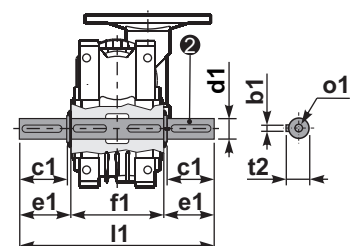

② kit cod. K045.5.029 type B
kit cod. KS045.5.031 type S

	b1	c1	d1	e1	f1	l1	m1	n1	t2	o1
type B	6	32	18 ^{-0.005} _{-0.020}	43	65	151	70	113	20.5	M6x18
type S	6	40	19 ^{-0.005} _{-0.020}	58.5	65	182	70	128.5	21.5	M8x20

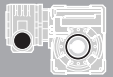

QUICK SELECTION / Selezione veloce

input speed (n_1) = 1400 min⁻¹

Output Speed n_2 [min ⁻¹]	Ratio i	Motor power P_{1M} [kW]	Output torque M_{2M} [Nm]	Service factor f.s.	Nominal power P_{1R} [kW]	Nominal torque M_{2R} [Nm]	Available B5 motor flanges		Available B14 motor flanges		Dynamic efficiency RD	Tooth Module $[mm]$	Ratios code
							A	B	O	P			
							56	63	56	63			
5.6	252	0.12	97	1.1	0.14	109	B		B-C		47	2.1	01
3.9	360	0.12	124	0.9	0.11	109	B		B-C		42	2.1	02
2.6	540	0.12*	109	<0.8	0.08	109	B		B-C		39	2.1	03
1.9	720	0.12*	109	<0.8	0.06	109	B		B-C		36	2.1	04
1.6	860	0.12*	109	<0.8	0.06	109	B		B-C		32	1.8	05
1.2	1200	0.12*	109	<0.8	0.05	109	B		B-C		27	1.3	06
1.0	1440	0.12*	109	<0.8	0.04	109	B		B-C		26	2.1	07
0.8	1720	0.12*	109	<0.8	0.04	109	B		B-C		25	1.8	08
0.6	2400	0.12*	104	<0.8	0.03	104	B		B-C		21	1.3	09

A) Motor Flanges Available
Flange Motore Disponibili

B) Supplied with Reduction Bushing
Fornito con Bussola di Riduzione

B) Available on Request without reduction bushing
Disponibile a Richiesta senza Bussola di Riduzione

C) Motor Flange Holes Position
Posizione Fori Flangia Motore

* Power higher than the maximum one which can be supported by the gearbox. Select according to the torque M_{2R}
Potenza superiore a quella massima sopportabile dal riduttore. Selezionare in base al momento torcente M_{2R}

EN Unit **53Q** is supplied with synthetic oil, providing "long life" lubrication. For mounting position V5-V6 please contact us. See table 1 for lubrication and recommended quantity. In table 2 please see possible radial loads and axial loads on the gearbox.

I Il riduttore tipo **53Q** viene fornito lubrificato a vita con olio sintetico. Per posizioni V5-V6 contattare il ns. servizio tecnico. Vedi tab.1 per oli e quantità consigliati. In tab.2 sono presenti i carichi radiali e assiali applicabili al riduttore.

D Für die Lebensdauerschmierung ist das Getriebe der Größe **53Q** mit synthetischem Öl befüllt. Bei Einbaulage V5 oder V6 bitten wir um Rücksprache. In Tabelle 1 ist die Schmiermenge und das empfohlene Schmiermittel angegeben. In Tabelle 2 sind die zulässigen Radial- und Axialbelastungen des Getriebes aufgeführt.

F Le réducteur de type **53Q** est fourni lubrifié à vie avec de l'huile synthétique. Concernant les positions V5.V6, contactez notre service d'assistance technique. Voir tableau 1 concernant les huiles et les quantités conseillées. Les charges radiales et axiales applicables au réducteur sont précisées dans le tableau 2.

E El reductor tamaño **53Q** se suministra, lubricado de por vida con aceite sintético. Para las posiciones V5 y V6 contactar con nuestro servicio técnico. Ver tabla 1, para cantidades y aceites recomendados. En la tabla 2, se encuentran las cargas radiales y axiales admitidas por el reductor.

0.14 Lt. **0.03 Lt.**

LUBRICATION 53Q Oil
Quantity 0.14/0.03 Lt.

AGIP Telium VSF 320	SHELL Omala S4 WE 320
----------------------------	------------------------------

For all details on lubrication and plugs check our website **tab. 1**
Per maggiori dettagli su lubrificazione e tappi olio vedi il nostro sito web

RADIAL AND AXIAL LOADS

Output shaft
Albero di uscita

n_2 [min ⁻¹]	FA [N]	FR [N]
25	480	2500
15	560	2800

Input shaft
albero in entrata

n_1 [min ⁻¹]	FA [N]	FR [N]
1400	20	100

*Strong axial loads in the DX direction are not allowed.
Non sono consentiti forti carichi assiali con direzione DX

tab. 2

P53QFB... Basic wormbox
Riduttore base

M. flanges	Kit code	øF	A
56B5	K030.4.041	120	61.5
63B5	K030.4.042	140	62.5
56B14	K030.4.046	80	61.5
63B14	K030.4.045	90	62.5

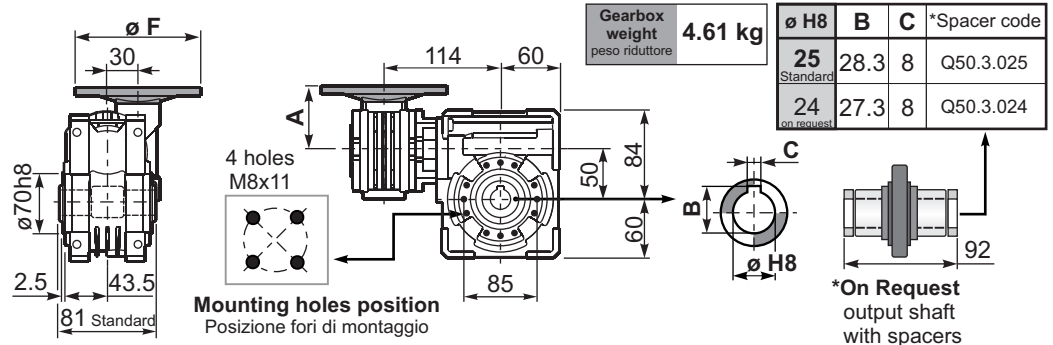

P53QFC... Square flange
Flangia quadrata

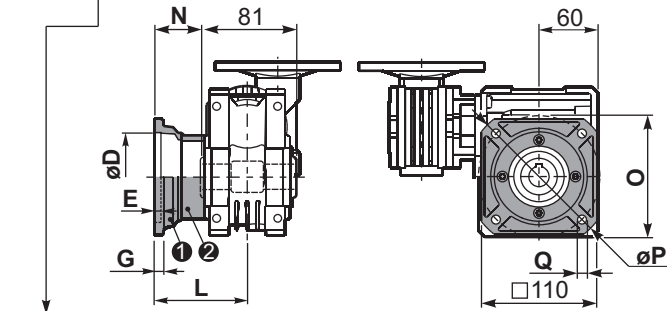

type B	øD	E	G	L	N	O	P	Q	kit code
FC	70 H8	5	9	90	49.5	85	125	11	KQ50.9.010
FL	70 H8	5	9	120	79.5	85	125	11	KQ50.9.011

P53QF1... Round flange
Flangia rotonda

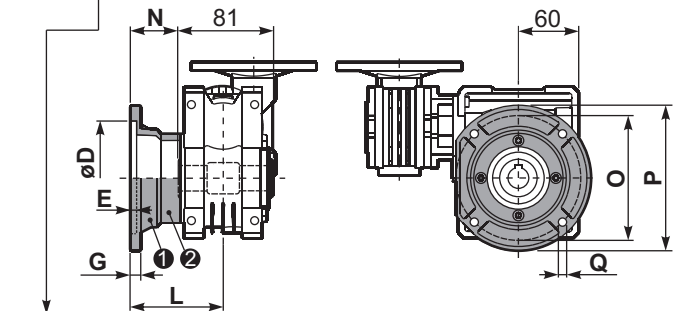

type S	øD	E	G	L	N	O	P	Q	kit code
F1	110 H8	5	10	89	48.5	130	160	9.5	KSQ50.9.012
F2	95 H8	5	14.5	72	31.5	115	140	11	KSQ50.9.013

P53QFB... Feet
Piedini

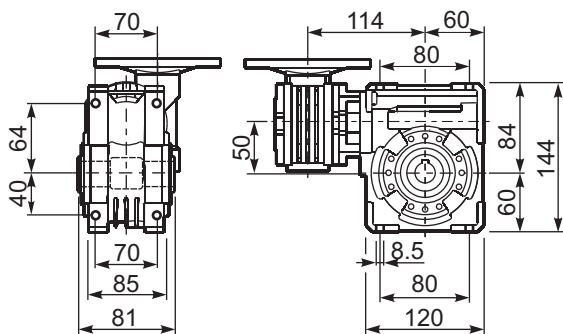

P53QBR... Reaction arm
Braccio di reazione

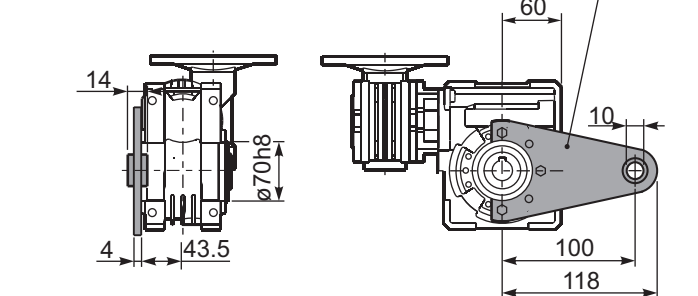

R53QFB... Input shaft
Albero in entrata

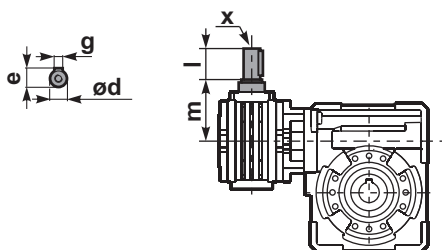

	ød	e	g	l	m	x	kit code
type B	9 h6	10.2	3	20	58	-	K030.5.006 PAM63
type S	-	-	-	-	-	-	-

P53Q.....S... Single Shaft
Albero lento semplice

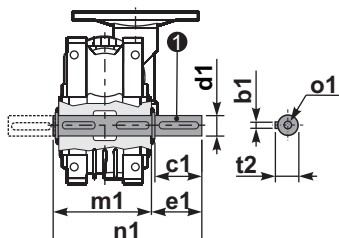

① kit cod. K050.5.028 type B
kit cod. KS050.5.030 type S

P53Q.....D... Double Shaft
Albero lento bisp.

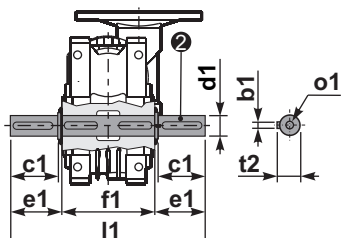

② kit cod. K050.5.029 type B
kit cod. KS050.5.031 type S

	b1	c1	d1	e1	f1	l1	m1	n1	t2	o1
type B	8	52	25 ^{-0.005} _{-0.020}	59.5	81	200	86.5	146	28	M8x20
type S	8	50	24 ^{-0.005} _{-0.020}	68.8	81	218	86.5	155	27	M8x20

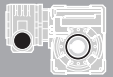

QUICK SELECTION / Selezione veloce

input speed (n_1) = 1400 min⁻¹

Output Speed n_2 [min ⁻¹]	Ratio i	Motor power P_{1M} [kW]	Output torque M_{2M} [Nm]	Service factor f.s.	Nominal power P_{1R} [kW]	Nominal torque M_{2R} [Nm]	Available B5 motor flanges		Available B14 motor flanges		Dynamic efficiency RD	Tooth Module [mm]	Ratios code
							A	B	O	P			
							56	63	56	63			
5.6	252	0.18	142	1.6	0.29	230	B		B-C		46	2.7	01
3.9	360	0.18	181	1.3	0.23	230	B		B-C		41	2.7	02
2.6	540	0.12	164	1.4	0.17	230	B		B-C		37	2.7	03
1.9	720	0.12	200	1.1	0.14	230	B		B-C		34	2.7	04
1.3	1080	0.12	265	0.9	0.10	230	B		B-C		30	2.7	05
1.0	1440	0.12*	230	<0.8	0.09	230	B		B-C		27	2.7	06
0.5	2745	0.12*	230	<0.8	0.05	230	B		B-C		23	2.1	07

A) Motor Flanges Available
Flange Motore Disponibili

B) Supplied with Reduction Bushing
Fornito con Bussola di Riduzione

B) Available on Request without reduction bushing
Disponibile a Richiesta senza Bussola di Riduzione

C) Motor Flange Holes Position
Posizione Fori Flangia Motore

* Power higher than the maximum one which can be supported by the gearbox. Select according to the torque M_{2R}
Potenza superiore a quella massima sopportabile dal riduttore. Selezionare in base al momento torcente M_{2R}

EN Unit **63Q** is supplied with synthetic oil, providing "long life" lubrication. For mounting position V5-V6 please contact us. See table 1 for lubrication and recommended quantity. In table 2 please see possible radial loads and axial loads on the gearbox.

I Il riduttore tipo **63Q** viene fornito lubrificato a vita con olio sintetico. Per posizioni V5-V6 contattare il ns. servizio tecnico. Vedi tab.1 per oli e quantità consigliati. In tab.2 sono presenti i carichi radiali e assiali applicabili al riduttore.

D Für die Lebensdauerschmierung ist das Getriebe der Größe **63Q** mit synthetischem Öl befüllt. Bei Einbaulage V5 oder V6 bitten wir um Rücksprache. In Tabelle 1 ist die Schmiermenge und das empfohlene Schmiermittel angegeben. In Tabelle 2 sind die zulässigen Radial- und Axialbelastungen des Getriebes aufgeführt.

F Le réducteur de type **63Q** est fourni lubrifié à vie avec de l'huile synthétique. Concernant les positions V5.V6, contactez notre service d'assistance technique. Voir tableau 1 concernant les huiles et les quantités conseillées. Les charges radiales et axiales applicables au réducteur sont précisées dans le tableau 2.

E El reductor tamaño **63Q** se suministra, lubricado de por vida con aceite sintético. Para las posiciones V5 y V6 contactar con nuestro servicio técnico. Ver tabla 1, para cantidades y aceites recomendados. En la tabla 2, se encuentran las cargas radiales y axiales admitidas por el reductor.

0.30 Lt.

■ LUBRICATION 63Q Oil Quantity 0.30/0.03 Lt.

AGIP Telium VSF 320 **SHELL** Omala S4 WE 320

For all details on lubrication and plugs check our website **tab. 1**
Per maggiori dettagli su lubrificazione e tappi olio vedi il nostro sito web

■ RADIAL AND AXIAL LOADS

Output shaft
Albero di uscita

n_2 [min ⁻¹]	FA [N]	FR [N]
25	700	3800
15	800	4000

Input shaft
albero in entrata

n_1 [min ⁻¹]	FA [N]	FR [N]
1400	20	100

*Strong axial loads in the DX direction are not allowed.
Non sono consentiti forti carichi assiali con direzione DX

tab. 2

P63QFB... Basic wormbox
Riduttore base

Gearbox weight
peso riduttore **7.25 kg**

M. flanges	Kit code	øF	A
56B5	K030.4.041	120	61.5
63B5	K030.4.042	140	62.5
56B14	K030.4.046	80	61.5
63B14	K030.4.045	90	62.5

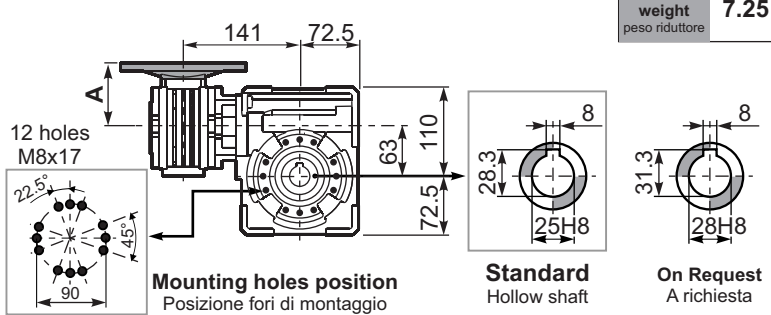
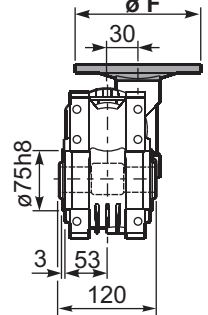

P63QFC... Square flange
Flangia quadrata

P63QF1... Round flange
Flangia rotonda

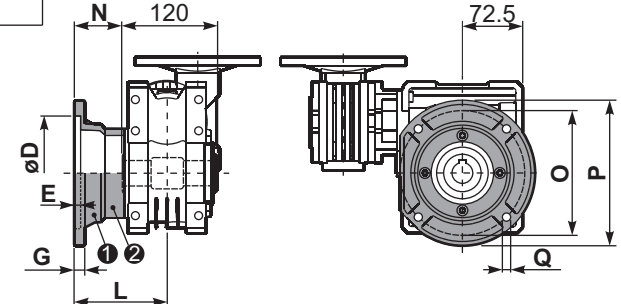
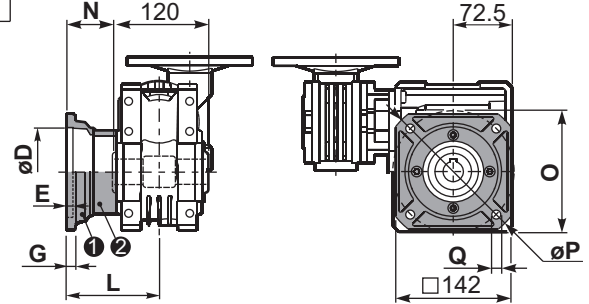

type B	øD	E	G	L	N	O	P	Q	kit code
FC	115 ^{+0.20} / _{+0.15}	6	12	86	26	150	180	11	1 KQ63.9.010 2 -
FL	115 ^{+0.20} / _{+0.15}	6	12	116	56	150	180	11	1 KQ63.9.010 2 K063.0.200

type S	øD	E	G	L	N	O	P	Q	kit code
F1	130 ^{+0.20} / _{+0.15}	7	13	110	50	165	200	13	1 KS070.9.013 2 -
F2	115 ^{+0.20} / _{+0.15}	7	13	124	64	150	175	11	1 KS063.9.013 2 -
F3	110 ^{+0.035} / ₀	5	11	90	30	130	160	10	1 KS063.9.011 2 -

P63QFB... Feet
Piedini

P63QBR... Reaction arm
Braccio di reazione

kit cod. K063.9.027

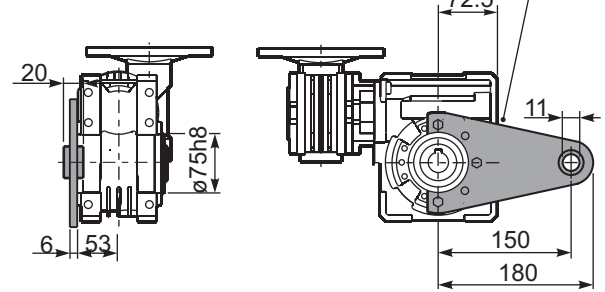
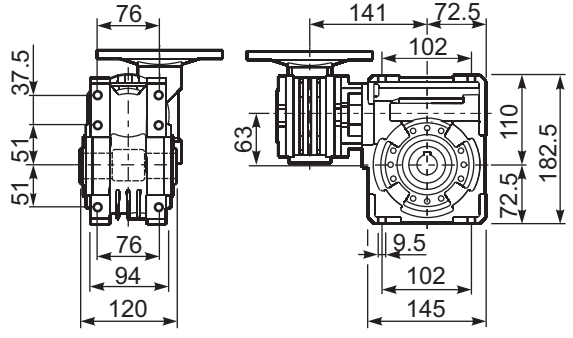

R63QFB... Input shaft
Albero in entrata

P63Q.....S... Single Shaft
Albero lento semplice

P63Q.....D... Double Shaft
Albero lento bisp.

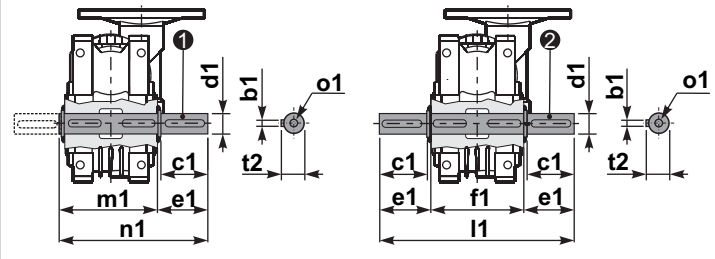
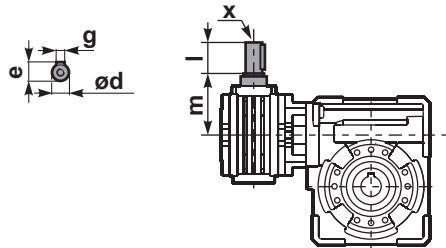

1 kit cod. K063.5.028 type B 2 kit cod. K063.5.029 type B

	ød	e	g	l	m	x	kit code
type B	9 h6	10.2	3	20	58	-	1 K030.5.006 PAM63 2 -
type S	-	-	-	-	-	-	1 - 2 -

	b1	c1	d1	e1	f1	l1	m1	n1	t2	o1
type B	8	60	25 ^{-0.005} / _{-0.020}	63.2	120	246.4	126.8	190	28	M8x20
type S	-	-	-	-	-	-	-	-	-	-

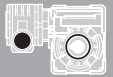

QUICK SELECTION / Selezione veloce

input speed (n_1) = 1400 min⁻¹

Output Speed n_2 [min ⁻¹]	Ratio i	Motor power P_{1M} [kW]	Output torque M_{2M} [Nm]	Service factor f.s.	Nominal power P_{1R} [kW]	Nominal torque M_{2R} [Nm]	Available B5 motor flanges		Available B14 motor flanges			Dynamic efficiency RD	Tooth Module [mm]	Ratios code
							B	C	O	P	Q			
							63	71	56	63	71			
5.6	252	0.25	198	1.3	0.33	265	B		B-C	B-C		46	2.7	01
3.9	360	0.18	186	1.4	0.26	265	B		B-C	B-C		42	2.7	02
2.8	504	0.18	241	1.1	0.20	265	B		B-C	B-C		39	2.7	03
1.9	756	0.12	204	1.3	0.16	265	B		B-C	B-C		33	2.7	04
1.4	1008	0.12	256	1.0	0.12	265	B		B-C	B-C		31	2.7	05
1.1	1332	0.12*	265	<0.8	0.10	265	B		B-C	B-C		30	2.7	06
0.8	1656	0.12*	265	<0.8	0.08	265	B		B-C	B-C		28	2.7	07
0.6	2160	0.12*	265	<0.8	0.07	265	B		B-C	B-C		26	2.7	08
0.6	2520	0.12*	265	<0.8	0.06	265	B		B-C	B-C		25	2.7	09

A Motor Flanges Available
Flange Motore Disponibili

B Supplied with Reduction Bushing
Fornito con Bussola di Riduzione

B Available on Request without reduction bushing
Disponibile a Richiesta senza Bussola di Riduzione

C Motor Flange Holes Position
Posizione Fori Flangia Motore

* Power higher than the maximum one which can be supported by the gearbox. Select according to the torque M_{2R}
Potenza superiore a quella massima sopportabile dal riduttore. Selezionare in base al momento torcente M_{2R}

EN Unit **64Q** is supplied with synthetic oil, providing "long life" lubrication. For mounting position V5-V6 please contact us. See table 1 for lubrication and recommended quantity. In table 2 please see possible radial loads and axial loads on the gearbox.

I Il riduttore tipo **64Q** viene fornito lubrificato a vita con olio sintetico. Per posizioni V5-V6 contattare il ns. servizio tecnico. Vedi tab.1 per oli e quantità consigliati. In tab.2 sono presenti i carichi radiali e assiali applicabili al riduttore.

D Für die Lebensdauerschmierung ist das Getriebe der Größe **64Q** mit synthetischem Öl befüllt. Bei Einbaulage V5 oder V6 bitten wir um Rücksprache. In Tabelle 1 ist die Schmiermenge und das empfohlene Schmiermittel angegeben. In Tabelle 2 sind die zulässigen Radial- und Axialbelastungen des Getriebes aufgeführt.

F Le réducteur de type **64Q** est fourni lubrifié à vie avec de l'huile synthétique. Concernant les positions V5.V6, contactez notre service d'assistance technique. Voir tableau 1 concernant les huiles et les quantités conseillées. Les charges radiales et axiales applicables au réducteur sont précisées dans le tableau 2.

E El reductor tamaño **64Q** se suministra, lubricado de por vida con aceite sintético. Para las posiciones V5 y V6 contactar con nuestro servicio técnico. Ver tabla 1, para cantidades y aceites recomendados. En la tabla 2, se encuentran las cargas radiales y axiales admitidas por el reductor.

0.30 Lt. **0.09 Lt.**

■ LUBRICATION 64Q Oil
Quantity 0.30/0.09 Lt.

AGIP Telium VSF 320	SHELL Omala S4 WE 320
----------------------------	------------------------------

For all details on lubrication and plugs check our website **tab. 1**
Per maggiori dettagli su lubrificazione e tappi olio vedi il nostro sito web

■ RADIAL AND AXIAL LOADS

Output shaft
Albero di uscita

n_2 [min ⁻¹]	FA [N]	FR [N]
25	700	3800
15	800	4000

Input shaft
albero in entrata

n_1 [min ⁻¹]	FA [N]	FR [N]
1400	42	210

***Strong axial loads in the DX direction are not allowed.**
Non sono consentiti forti carichi assiali con direzione DX

tab. 2

P64QFB... Basic wormbox
Riduttore base

Gearbox weight
peso riduttore **7.25 kg**

M. flanges	Kit code	øF	A
63B5	K050.4.041	138	74
71B5	K050.4.042	160	71.5
56B14	KC40.4.049	80	71.5
63B14	K050.4.047	90	74
71B14	K050.4.045	105	71.5

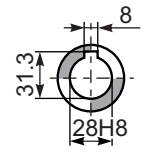
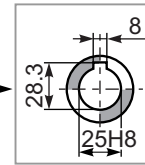
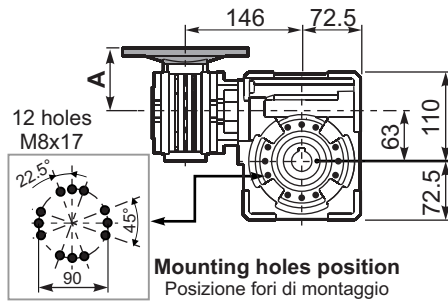
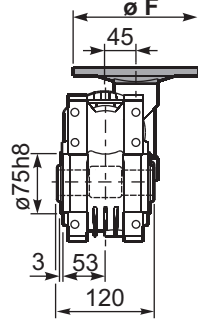

Mounting holes position
Posizione fori di montaggio

Standard
Hollow shaft

On Request
A richiesta

P64QFC... Square flange
Flangia quadrata

P64QF1... Round flange
Flangia rotonda

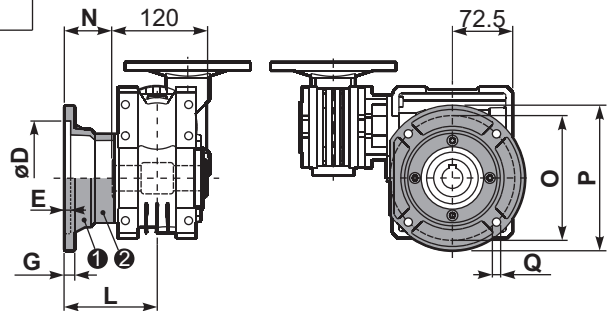
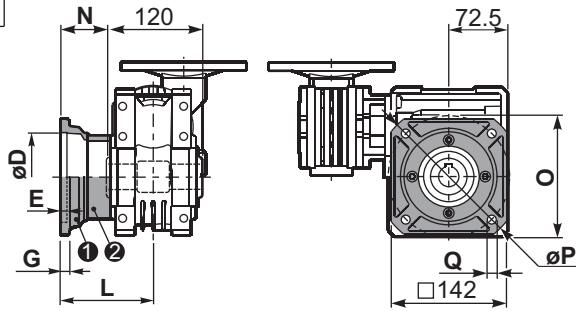

type B	øD	E	G	L	N	O	P	Q	kit code
FC	115 ^{+0.20} / _{+0.15}	6	12	86	26	150	180	11	① KQ63.9.010 ② -
FL	115 ^{+0.20} / _{+0.15}	6	12	116	56	150	180	11	① KQ63.9.010 ② K063.0.200

type S	øD	E	G	L	N	O	P	Q	kit code
F1	130 ^{+0.20} / _{+0.15}	7	13	110	50	165	200	13	① KS070.9.013 ② -
F2	115 ^{+0.20} / _{+0.15}	7	13	124	64	150	175	11	① KS063.9.013 ② -
F3	110 ^{+0.035} / ₀	5	11	90	30	130	160	10	① KS063.9.011 ② -

P64QFB... Feet
Piedi

P64QBR... Reaction arm
Braccio di reazione

kit cod. K063.9.027

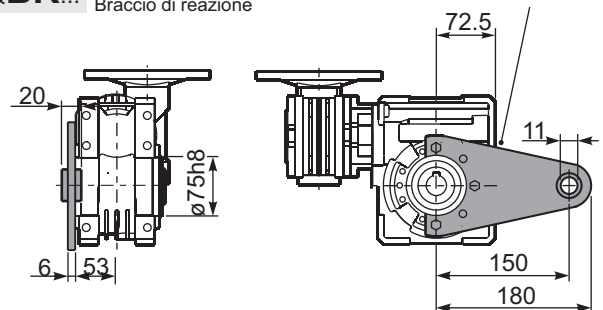
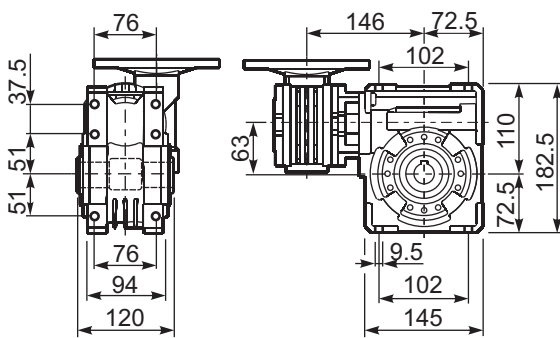

R64QFB... Input shaft
Albero in entrata

P64Q.....S... Single Shaft
Albero lento semplice

P64Q.....D... Double Shaft
Albero lento bisp.

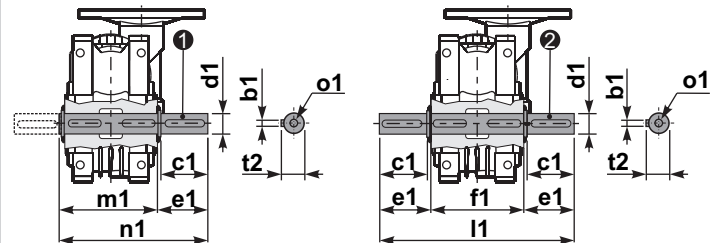
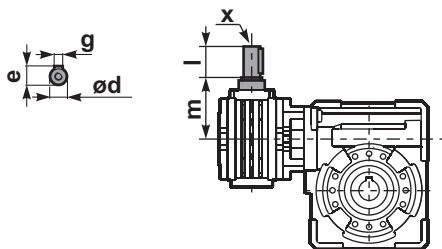

① kit cod. K063.5.028 type B

② kit cod. K063.5.029 type B

	ød	e	g	l	m	x	kit code
type B	11 h6	12.5	4	30	68	-	① K045.5.006 PAM71 ② -
type S	-	-	-	-	-	-	① - ② -

	b1	c1	d1	e1	f1	l1	m1	n1	t2	o1
type B	8	60	25 ^{-0.005} / _{-0.020}	63.2	120	246.4	126.8	190	28	M8x20
type S	-	-	-	-	-	-	-	-	-	-

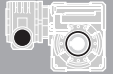

QUICK SELECTION / Selezione veloce

input speed (n_1) = 1400 min⁻¹

Output Speed n_2 [min ⁻¹]	Ratio i	Motor power P_{1M} [kW]	Output torque M_{2M} [Nm]	Service factor f.s.	Nominal power P_{1R} [kW]	Nominal torque M_{2R} [Nm]	Available B5 motor flanges		Available B14 motor flanges			Dynamic efficiency RD	Tooth Module [mm]	Ratios code
							B	C	O	P	Q			
							63	71	56	63	71			
5	280	0.37	403	0.9	0.33	359	B		B-C	B-C		57	3.10	01
3.5	400	0.25	314	1.1	0.29	359	B		B-C	B-C		46	3.10	02
2.5	560	0.25	420	0.9	0.21	359	B		B-C	B-C		44	3.10	03
1.7	840	0.18	423	0.8	0.15	359	B		B-C	B-C		41	3.10	04
1.3	1120	0.12	339	1.1	0.13	359	B		B-C	B-C		37	3.10	05
0.9	1480	0.09	336	1.1	0.10	359	B		B-C	B-C		37	3.10	06
0.8	1840	0.09	373	1.0	0.09	359	B		B-C	B-C		33	3.10	07
0.6	2400	0.06	275	1.3	0.08	359	B		B-C	B-C		28	3.10	08
0.5	2800	0.06	298	1.2	0.07	359	B		B-C	B-C		26	3.10	09
0.3	4080	0.06	250	1.4	0.09	359	B		B-C	B-C		15	3.10	10

A Motor Flanges Available
Flange Motore Disponibili

B Supplied with Reduction Bushing
Fornito con Bussola di Riduzione

B Available on Request without reduction bushing
Disponibile a Richiesta senza Bussola di Riduzione

C Motor Flange Holes Position
Posizione Fori Flangia Motore

EN Unit **74Q** is supplied with synthetic oil, providing "long life" lubrication. For mounting position V5-V6 please contact us. See table 1 for lubrication and recommended quantity. In table 2 please see possible radial loads and axial loads on the gearbox.

I Il riduttore tipo **74Q** viene fornito lubrificato a vita con olio sintetico. Per posizioni V5-V6 contattare il ns. servizio tecnico. Vedi tab.1 per oli e quantità consigliati. In tab.2 sono presenti i carichi radiali e assiali applicabili al riduttore.

D Für die Lebensdauerschmierung ist das Getriebe der Größe **74Q** mit synthetischem Öl befüllt. Bei Einbaulage V5 oder V6 bitten wir um Rücksprache. In Tabelle 1 ist die Schmiermenge und das empfohlene Schmiermittel angegeben. In Tabelle 2 sind die zulässigen Radial- und Axialbelastungen des Getriebes aufgeführt.

F Le réducteur de type **74Q** est fourni lubrifié à vie avec de l'huile synthétique. Concernant les positions V5.V6, contactez notre service d'assistance technique. Voir tableau 1 concernant les huiles et les quantités conseillées. Les charges radiales et axiales applicables au réducteur sont précisées dans le tableau 2.

E El reductor tamaño **74Q** se suministra, lubricado de por vida con aceite sintético. Para las posiciones V5 y V6 contactar con nuestro servicio técnico. Ver tabla 1, para cantidades y aceites recomendados. En la tabla 2, se encuentran las cargas radiales y axiales admitidas por el reductor.

0.40 Lt.

■ LUBRICATION 74Q Oil
Quantity 0.40/0.09 Lt.

0.09 Lt.

AGIP Telium VSF 320

SHELL Omala S4 WE 320

For all details on lubrication and plugs check our website **tab. 1**
Per maggiori dettagli su lubrificazione e tappi olio vedi il nostro sito web

RADIAL AND AXIAL LOADS

Output shaft
Albero di uscita

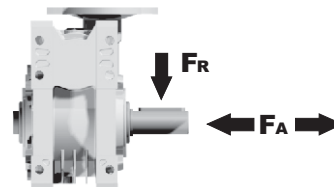

n_2 [min ⁻¹]	FA [N]	FR [N]
25	880	4400
15	1000	5000

Input shaft
albero in entrata

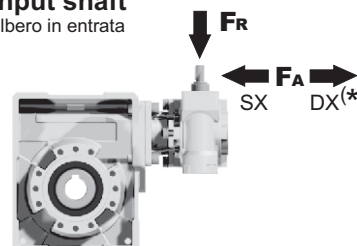

n_1 [min ⁻¹]	FA [N]	FR [N]
1400	42	210

***Strong axial loads in the DX direction are not allowed.**
Non sono consentiti forti carichi assiali con direzione DX

tab. 2

P74QFB... Basic wormbox
Riduttore base

Gearbox weight
peso riduttore **11.4 kg**

M. flanges	Kit code	øF	A
63B5	K050.4.041	138	74
71B5	K050.4.042	160	71.5
56B14	KC40.4.049	80	71.5
63B14	K050.4.047	90	74
71B14	K050.4.045	105	71.5

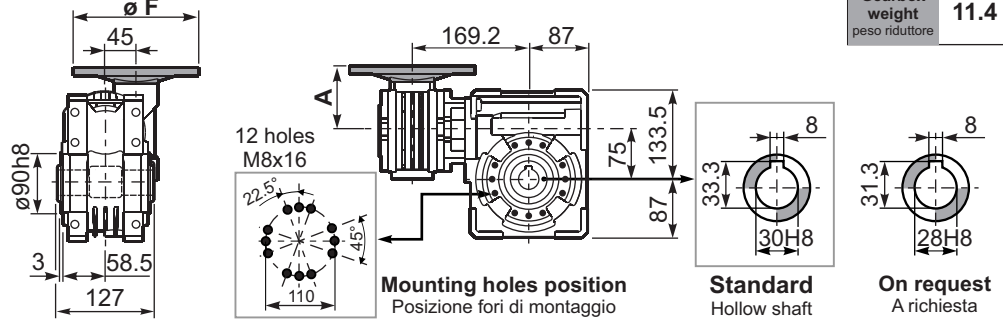

P74QFC... Square flange
Flangia quadrata

P74QFL... Square flange
Flangia quadrata

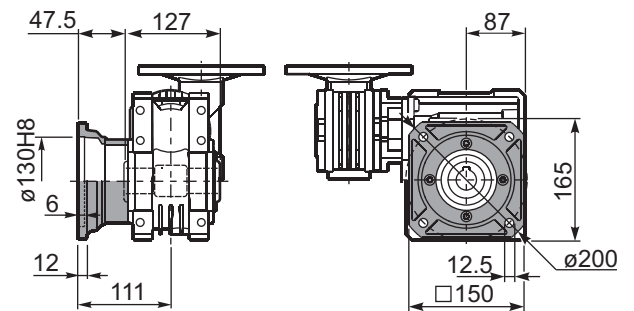
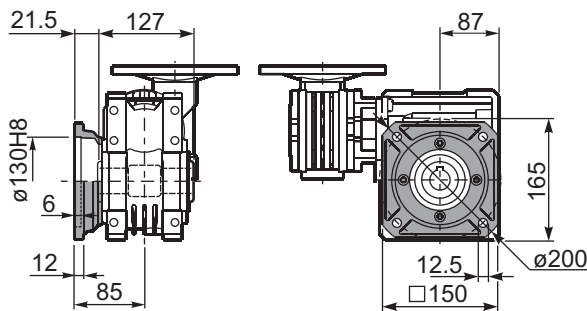

P74QFB... Feet
Piedini

P74QBR... Reaction arm
Braccio di reazione

kit cod. KQ75.9.027

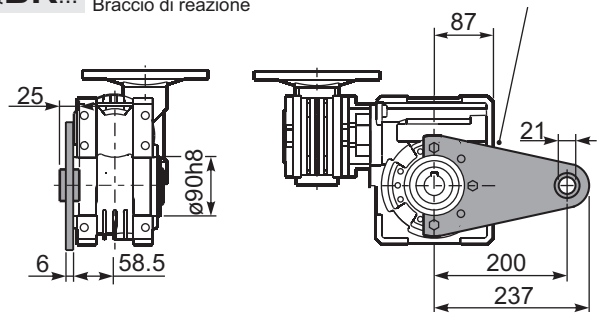
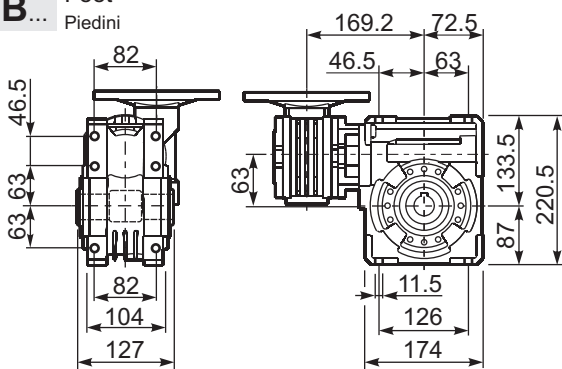

R74QFB... Input shaft
Albero in entrata

P74Q.....S... Single Shaft
Albero lento semplice

P74Q.....D... Double Shaft
Albero lento bisp.

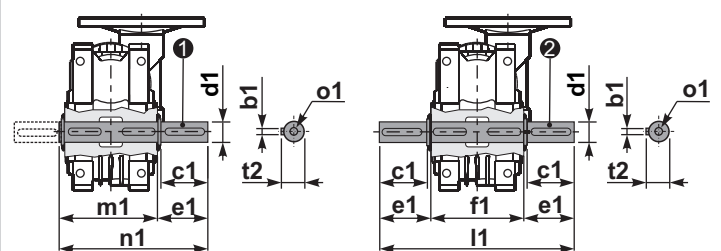
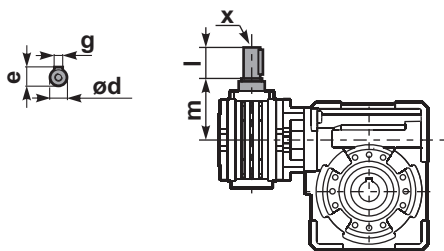

① kit cod. KQ75.5.028 Standard
kit cod. KQ75.5.026 On request

② kit cod. KQ75.5.029 Standard
kit cod. KQ75.5.027 On request

	ød	e	g	l	m	x	kit code
type B	11 h6	12.5	4	30	68	-	① K045.5.006 PAM71 ② -
type S	-	-	-	-	-	-	① - ② -

	b1	c1	d1	e1	f1	l1	m1	n1	t2	o1
Standard	8	60	30 ^{-0.005} _{-0.020}	65	127	255	134	199	33	M8x20
On request	8	60	28 ^{-0.005} _{-0.020}	65	127	255	134	199	31	M8x20

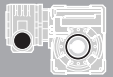

QUICK SELECTION / Selezione veloce

input speed (n_1) = 1400 min⁻¹

Output Speed n_2 [min ⁻¹]	Ratio i	Motor power P_{1M} [kW]	Output torque M_{2M} [Nm]	Service factor f.s.	Nominal power P_{1R} [kW]	Nominal torque M_{2R} [Nm]	Available B5 motor flanges		Available B14 motor flanges			Dynamic efficiency RD	Tooth Module [mm]	Ratios code
							B	C	O	P	Q			
							63	71	56	63	71			
10	140	0.37	205	1.8	0.66	368	B		B-C	B-C		58	4.5	01
7.1	196	0.37	257	1.4	0.53	368	B		B-C	B-C		52	4.7	02
5.0	280	0.37	332	1.6	0.58	518	B		B-C	B-C		47	4.7	03
3.6	392	0.37	435	1.2	0.44	518	B		B-C	B-C		44	4.7	04
2.4	588	0.25	371	1.4	0.35	518	B		B-C	B-C		37	4.7	05
1.8	784	0.25	455	1.1	0.28	518	B		B-C	B-C		34	4.7	06
1.4	1036	0.18	420	1.2	0.22	518	B		B-C	B-C		33	4.7	07
1.1	1288	0.18	474	1.1	0.20	518	B		B-C	B-C		30	4.7	08
0.7	1960	0.12	449	1.2	0.14	518	B		B-C	B-C		28	4.7	09
0.5	2856	0.12	584	0.9	0.11	518	B		B-C	B-C		25	4.7	10

A Motor Flanges Available
Flange Motore Disponibili

B Supplied with Reduction Bushing
Fornito con Bussola di Riduzione

B Available on Request without reduction bushing
Disponibile a Richiesta senza Bussola di Riduzione

C Motor Flange Holes Position
Posizione Fori Flangia Motore

EN Unit **84Q** is supplied with synthetic oil, providing "long life" lubrication. For mounting position V5-V6 please contact us. See table 1 for lubrication and recommended quantity. In table 2 please see possible radial loads and axial loads on the gearbox.

I Il riduttore tipo **84Q** viene fornito lubrificato a vita con olio sintetico. Per posizioni V5-V6 contattare il ns. servizio tecnico. Vedi tab.1 per oli e quantità consigliati. In tab.2 sono presenti i carichi radiali e assiali applicabili al riduttore.

D Für die Lebensdauerschmierung ist das Getriebe der Größe **84Q** mit synthetischem Öl befüllt. Bei Einbaulage V5 oder V6 bitten wir um Rücksprache. In Tabelle 1 ist die Schmiermenge und das empfohlene Schmiermittel angegeben. In Tabelle 2 sind die zulässigen Radial- und Axialbelastungen des Getriebes aufgeführt.

F Le réducteur de type **84Q** est fourni lubrifié à vie avec de l'huile synthétique. Concernant les positions V5.V6, contactez notre service d'assistance technique. Voir tableau 1 concernant les huiles et les quantités conseillées. Les charges radiales et axiales applicables au réducteur sont précisées dans le tableau 2.

E El reductor tamaño **84Q** se suministra, lubricado de por vida con aceite sintético. Para las posiciones V5 y V6 contactar con nuestro servicio técnico. Ver tabla 1, para cantidades y aceites recomendados. En la tabla 2, se encuentran las cargas radiales y axiales admitidas por el reductor.

B3	B6	B7	B8	V5	V6
1.2/0.09LT	1.2/0.09 LT	1.2/0.09 LT	1.2/0.09 LT	1.2/0.09 LT	1.2/0.09 LT
AGIP Telium VSF 320			SHELL Omala S4 WE 320		

For all details on lubrication and plugs check our website **tab. 1**
Per maggiori dettagli su lubrificazione e tappi olio vedi il nostro sito web

RADIAL AND AXIAL LOADS

Output shaft

Albero di uscita

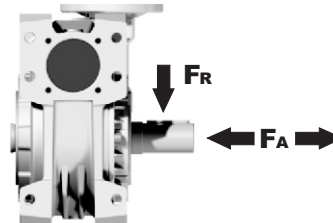

n_2 [min ⁻¹]	FA [N]	FR [N]
25	1000	5000
15	1160	5800

Input shaft

albero in entrata

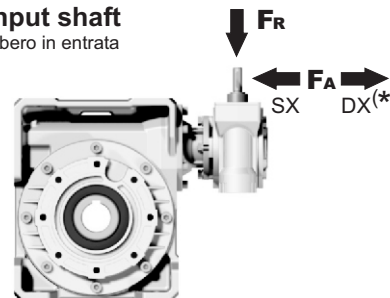

n_1 [min ⁻¹]	FA [N]	FR [N]
1400	42	210

***Strong axial loads in the DX direction are not allowed.**
Non sono consentiti forti carichi assiali con direzione DX

tab. 2

P84QFB... Basic wormbox
Riduttore base

Gearbox weight
peso riduttore **16.2 kg**

M. flanges	Kit code	øF	A
63B5	K050.4.041	138	74
71B5	K050.4.042	160	71.5
56B14	KC40.4.049	80	71.5
63B14	K050.4.047	90	74
71B14	K050.4.045	105	71.5

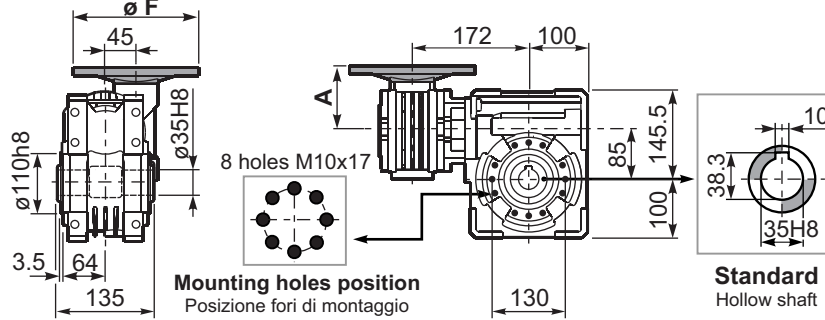

P84QFC... Output flange
Flangia uscita

P84QF1... Output flange
Flangia uscita

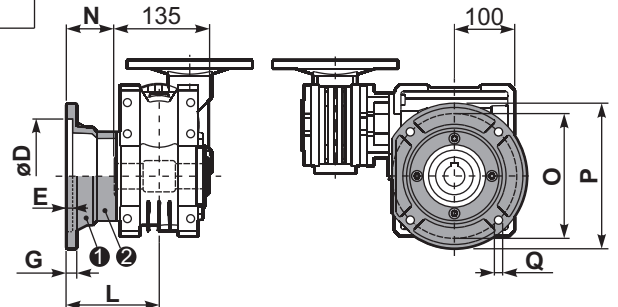
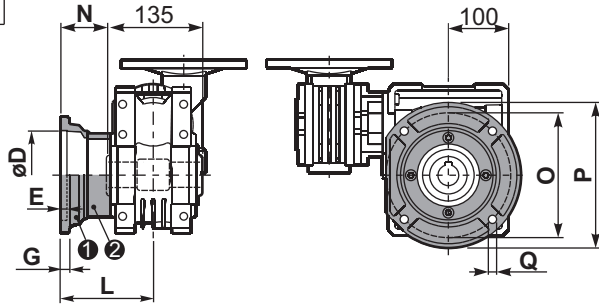

type B	øD	E	G	L	N	O	P	Q	kit code
FC	152 ^{+0.06} / _{+0.00}	5	16	108	40.5	176	205	13	1 K085.9.010 2 -
FL	152 ^{+0.06} / _{+0.00}	5	16	148.5	81	176	205	13	1 K085.9.010 2 K085.0.201

type S	øD	E	G	L	N	O	P	Q	kit code
F1	130 H7	5	13	117.5	50	165	200	11.5	1 KS085.9.012 2 -
F2	152 ^{+0.06} / _{+0.00}	5	15	147.5	80	180	205	12.5	1 KS085.9.013 2 -
F4	130 H7	5	13	106.5	39	165	200	13	1 KS085.9.015 2 -

P84QFB... Feet
Piedi

P84QBR... Reaction arm
Braccio di reazione

kit cod. K085.9.027

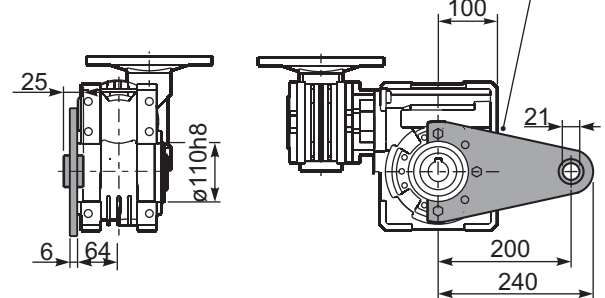
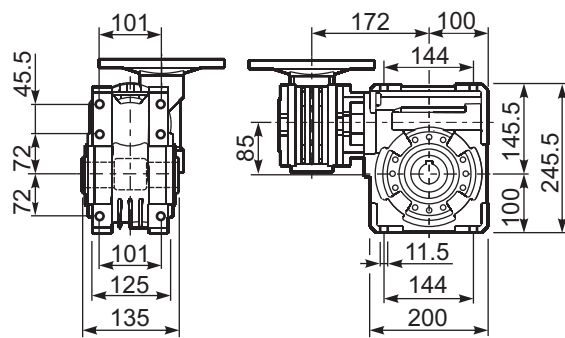

R84QFB... Input shaft
Albero in entrata

P84Q.....S... Single Shaft
Albero lento semplice

P84Q.....D... Double Shaft
Albero lento bisp.

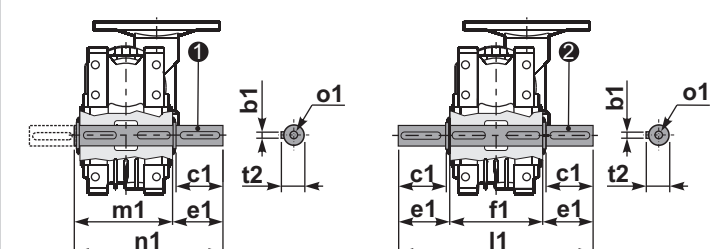
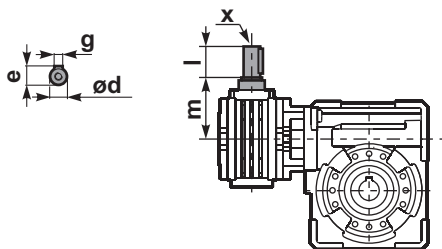

1 kit cod. K085.5.028 type B 2 kit cod. K085.5.029 type B

	ød	e	g	l	m	x	kit code
type B	11 h6	12.5	4	30	68	-	1 K045.5.006 PAM71 2 -
type S	-	-	-	-	-	-	1 - 2 -

	b1	c1	d1	e1	f1	l1	m1	n1	t2	o1
type B	10	60	35 ^{-0.005} / _{-0.020}	73.5	135	282	141	214.5	38	M10x23
type S	-	-	-	-	-	-	-	-	-	-

Worm gearboxes type S30 ÷ S63

A modular and compact product

3

Single piece alloy steel input shaft and worm shaft.

High helix angle worm is case-hardened (Rc 58-60), ground, teeth are profiled and radiused, for noise reduction and enhanced efficiency.

Oversized bearings

Support positively-retained, high speed shaft for higher shock load capacity - ideal for frequent starting and reversing application. Premium, Nitrile® high temperature seals each end.

Premium, high temperature

Nitrile® output seals

Flange

Fully modular to IEC and compact integrated motor. NEMA C flange.

Bronze Nickel worm gears.

Is centrifugally cast onto an iron hub for maximum strength and superior life.

Oversize bearing

For radial load capability and maximum hollow output shaft diameter.

Standard hollow output shaft mounting

Reduces total drive envelope size, weight and cost. Single and double solid output shaft is available.

Impregnated and machined bearing caps

With exterior machined surfaces enable a variety of mounting accessories. Extra-deep thread engagement provided for greater support strength. Zinc plated hardware.

Single-piece aluminum alloy housing

Is vacuum impregnated (MIL-STD 276) for protection and sealing. No secondary finish required but readily accepts paint. Combines light weight with high tensile strength. Precision machined for alignment of bearings and gearing.

Vent Free Design.

No breather or vents to leak! Factory lubricated for life with synthetic, semi-fluid gear lubricant with an operating range of -15°C to 130°C.

oil free



vent free



World wide sales network.

Specific type datasheet on page...

On page / A pagina / Auf Seite / À la page / En la página

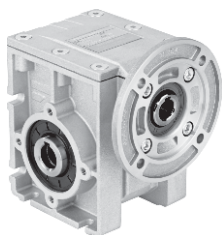

Types / Tipi /
Tipen / Types /
Tipos →

3-5	3-7	3-9	3-11
S30 21Nm	S45 41Nm	S50 72Nm	S63 147Nm

On page / A pagina / Auf Seite / À la page / En la página

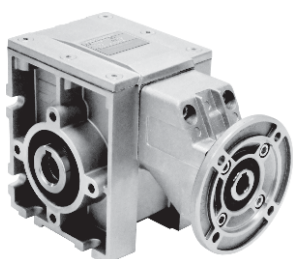

Types / Tipi /
Tipen / Types /
Tipos →

3-13	3-15	3-17
PS4 55Nm	PS5 88Nm	PS6 187Nm

On page / A pagina / Auf Seite / À la page / En la página

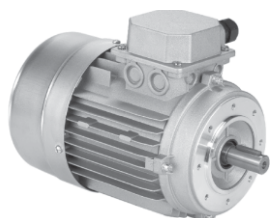

Types / Tipi /
Tipen / Types /
Tipos →

M-1									
56A 56B	63A 63B	71A 71B	80A 80B	90S 90L	100LA 100LB	112M	132S 132M	160M 160L	180M 180L

Type - Tipo - Typ
Type - Tipo

Size - Grandezza
Größe - Taille
Tamaño

Mounting - Montaggio - Montage Fixation
Fixation - Tipo de montaje

P

S45

FB

Worm gearboxes
Riduttori a vite senza fine
Schneckengetriebe
Reducteurs a vis sans fin
Reductores de corona sin fin

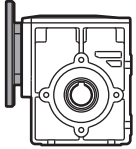

P

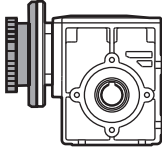

M

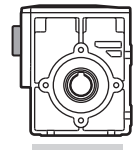

B

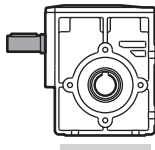

R

S30
S45
S50
S63

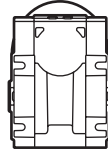

FB

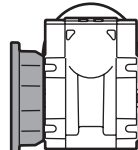

FM

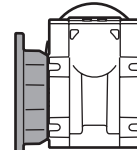

FN

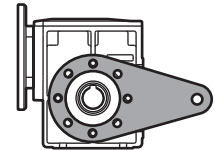

BR

Worm gearboxes with primary reduction
Riduttori a vite senza fine con precoppia
Schneckengetriebe mit stirnradstufe am Eintrieb
Reducteurs a vis sans fin avec pré-réduction
Reductores corona sin fin con prereducora de engranajes

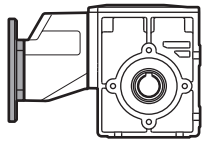

P

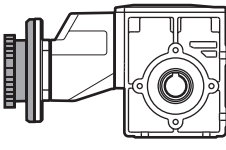

M

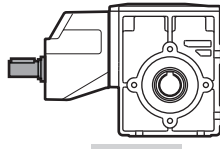

R

PS4
PS5
PS6

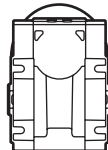

FB

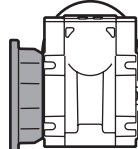

FM

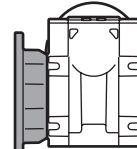



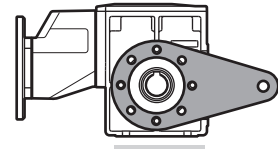

FN

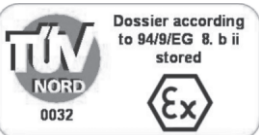

BR

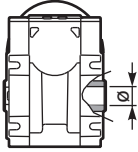
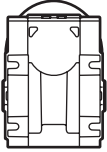
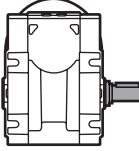
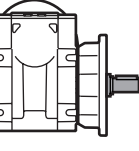
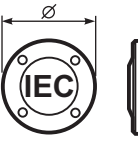

On request we can deliver our products according to the ATEX
A richiesta possiamo fornire i nostri prodotti secondo le normative ATEX
Auf Anfrage können wir unsere Produkte den Richtlinien ATEX entsprechend liefern
Sur demande nos produits peuvent se conformer à la réglementation ATEX
A pedido, se pueden enviar nuestros productos de acuerdo con las normas ATEX.

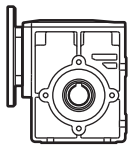
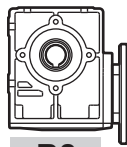
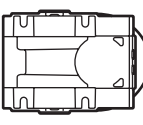
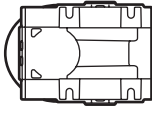
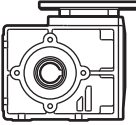
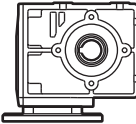
Ratio Rapporto Untersetzung Reduction Relación	Hub Mozzo corona Hohlwelle Arbre creux Nucleo corona	Output shaft Albero lento Abtriebswelle Arbre de sortie Eje solida	Motor size Grandezza motore Motor Grösse Grandeur moteur Tamaño motor	Terminal box position Posizione morsettiera Klemmkastenlage Position boîte a bornes Posición caja de bornes	Mounting position Posizione montaggio Einbaulage Position de montage Position de montaje	Reduced Input bore Foro entrata ridotto Reduzierte Eingangshohlwelle Trou d'entree de diametre reduit Eje hueco de entrada reducido
10	C	Ø	-Q	B	B3	-
<p>See technical data table</p> <p>Vedi tabella dati tecnici.</p> <p>Technisches Datenblatt beachten</p> <p>Voir tableau données techniques</p> <p>Ver tabla datos técnicos</p>	 <p>C STANDARD</p> <p>S30 ⇨ $\varnothing 16$ S45 ⇨ $\varnothing 20$ S50 ⇨ $\varnothing 20$ S63 ⇨ $\varnothing 30$</p> <p>I Stainless steel hub Mozzo in acciaio Inox Edelstahlhohlwelle Moyeu en acier Inox Nucleo corona de acero Inox</p>	 <p>Ø HOLLOW</p>  <p>S EXTENDED</p>  <p>R</p> <p>With flange and special shaft for high radial loads</p> <p>Con flange e albero in uscita speciale per alti carichi radiali</p> <p>Only with FM or FN</p> <p>Solo con FM o FN</p>	 <p>-M without flange Senza flangia</p> <p>B5</p> <p>-B=63 ($\varnothing 140$) -C=71 ($\varnothing 160$) -D=80 ($\varnothing 200$) -E=90 ($\varnothing 200$)</p> <p>B14</p> <p>-O=56 ($\varnothing 80$) -P=63 ($\varnothing 90$) -Q=71 ($\varnothing 105$) -R=80 ($\varnothing 120$) -T=90 ($\varnothing 140$)</p> <p>-0=Type R</p>	 <p>A</p>  <p>B STANDARD</p>  <p>C</p>  <p>D</p>	 <p>B3</p>  <p>B8</p>  <p>B6</p>  <p>B7</p>  <p>V5</p>  <p>V6</p>	<p>-</p> <p>Not indication standard bore</p> <p>Nessuna indicazione foro standard</p> <p>P Input bore reduced one size</p> <p>Foro entrata ridotto di una misura</p> <p>Ex. Input Flange 71 B14 Standard $\varnothing 14$ Reduced $\varnothing 11$</p> <p>Q Input bore reduced two sizes</p> <p>Due grandezze ridutte foro entrata</p> <p>Ex. Input Flange 71 B14 Standard $\varnothing 14$ Reduced $\varnothing 9$</p>

POTENZA RICHIESTA / REQUIRED POWER / ERFORDERLICHE LEISTUNG / PUISSANCE NECESSAIRE / POTENCIA NECESARIA

Lifting / sollevamento / hubantriebe / levage / elevación

$$P [KW] = \frac{M [Kg] \cdot g [9.81] \cdot v [m / s]}{1000}$$

Rotation / rotazione / drehung / rotation / rotação

$$P [KW] = \frac{M [Nm] \cdot n [rpm]}{9550}$$

Linear movement / traslazione / linearbewegung / translation / translación

$$P [KW] = \frac{F [N] \cdot v [m / s]}{1000}$$

3

TORQUE / COPPIA / DREHMOMENT / COUPLE / PAR

$$M [Nm] = \frac{9550 \cdot P[KW]}{n [rpm]}$$

$$M [lb in] = \frac{63030 \cdot P[HP]}{n [rpm]}$$

RADIAL LOADS / CARICHI RADIALI / RADIALE - UND AXIALLASTEN / CHARGES RADIALES / CARGA RADIAL Y AXIAL

- Radial load generated by external transmissions keyed onto input and/or output shafts.
- Forza radiale generata da organi di trasmissione calettati sugli alberi di ingresso e/o uscita.
- Belastungen der Antriebs- bzw. Abtriebswellen durch von aussen eingebrachte Radiallasten.
- Charge radiale générée par la transmissions calés sur les entrées et / ou des arbres de sortie
- Cargas radiales, generada por transmisiones externas, aplicadas sobre los ejes de entrada y/o salida

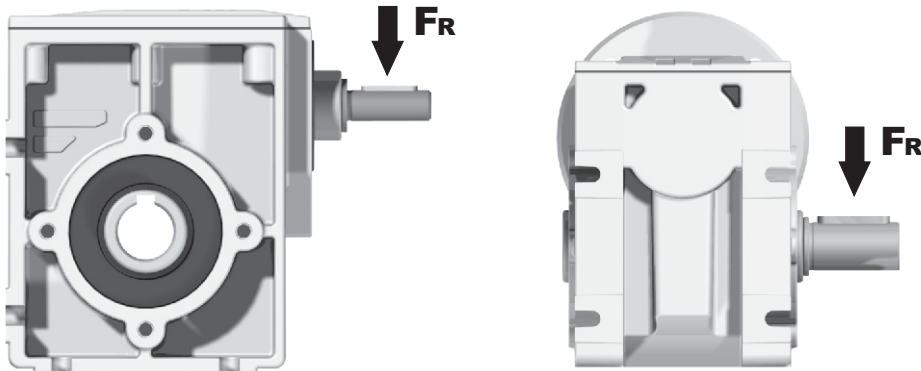

	$F_R [N] = \frac{M [Nm] \cdot 2000}{d [mm]} \cdot f_k$	$F_R [N] = \frac{M [lb in] \cdot 8.9}{d [in]} \cdot f_k$
M	Momento torcente / Output torque / Abtriebsdrehmoment / Couple / Par torsion	
d	Diametro primitivo / Diam. of driving element / Durchmesser der Abtriebseinheit / Diamètre primitif / Diámetro primitivo	
f_k	Coefficiente di trasformazione / Factor / Faktor / Coefficient de transmission / Coeficiente de transmisión 1.15 Ingranaggi / Gearwheels / Zahnrad / Engrenage / Engranaje 1.25 Catena / Chain sprockets / Antriebskette / Chaîne / Cadena 1.75 Cinghia Trapezoidale / Narrow v-belt pulley / Keilriemen / Courroie trap. / Correa trapezoidal 2.50 Cinghia piatta / Flat-belt pulley / Flachzahnriem. / Courroie crantée / Correa plana	

- If your application requires higher radial loads, contact our technical office. Higher load may be possible.
- Nel caso la vostra applicazione richieda carichi radiali superiori consultare il nostro ufficio tecnico, valori maggiori possono essere accettati.
- Wenn Ihre Anwendung höhere Radialbelastungen erfordert, so wenden Sie sich bitte an unser technischen Büro.
- Si votre application demande des charges radiales supérieures, s'adresser à notre bureau technique.
- En el caso en que una aplicación exija una carga radial superior a la especificada en el catálogo, consultar a nuestra oficinas técnica.

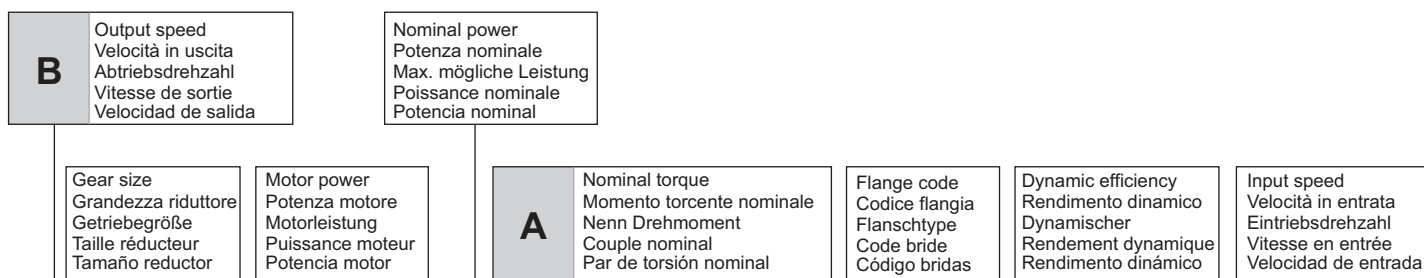

S45 High tech worm - Gear

41Nm

Rating - Aluminum WORM GEARBOXES



QUICK SELECTION / Selezione veloce

input speed (n₁) = 1400 min⁻¹

Output Speed n ₂ [min ⁻¹]	Ratio i	Motor power P _{1M} [kW]	Output torque M _{2M} [Nm]	Service factor f.s.	Nominal power P _{1R} [kW]	Nominal torque M _{2R} [Nm]	Available B5 motor flanges		Available B14 motor flanges			Dynamic efficiency RD	Tooth Module [mm]	Ratios code
							B	C	O	P	Q			
200	7	0.37	14	2.2	0.80	30	B		B-C	B-C		80	2.2	01
140	10	0.37	20	1.5	0.57	30	B		B-C	B-C		79	2.2	02
100	14	0.37	27	1.1	0.41	30	B		B-C	B-C		77	2.4	03

C Ratio
Rapporto
Untersetzung
Rapport de réduction
Relación

Nominal module
Modulo nominale
Nenn modul
Module nominale
Módulo nominal

Notes
Note
Anmerkungen
Note
Notas

Transmitted torque
Momento torcente trasmesso
Mögliche Drehmomente
Couple de sortie
Par transmitido

Service factor
Fattore di servizio
Betriebsfaktor
Facteur de service
Factor de servicio

fs		Oper. hours per day Ore di funz. giorn.		
Type of load and starts per hour Tipo di carico e avviamenti per ora		<2 h	2 - 8 h	8 - 16 h
Continuous or intermittent appl. with start / hour Applicazione cont. o interm. con n.ro operazioni/ora	Uniform / Uniforme	0.9	1	1.25
	Moderate / Moderato	1	1.25	1.5
	Heavy / Forte	1.25	1.5	1.75
Intermittent application with start / hour Applicazione intermittente con n.ro operazioni/ora	Uniform / Uniforme	1.25	1.5	1.75
	Moderate / Moderato	1.5	1.75	2
	Heavy / Forte	1.75	2	2.25

D	Motor flange available Flange disponibili Erhältliche Motorflansche Brides disponibles Bridas disponibles	
B)	Mounting with reduction ring Montaggio con boccola di riduzione Reduzierhülsen Montage avec douille de réduction Montaje con casquillo de reducción	
C)	Motor flangeholes position/terminal box position Posizione fori flangia/basetta motore Bohrungsposition am Motorflansch/-socket Position trous bride/barrette à bornes moteur Posición agujeros brida / base motor	
B)	Available without reduction bushes Disponibile anche senza boccola Auch ohne Reduzierbuchse verfügbar Disponible aussi sans douille de réduction Disponible también sin casquillo	

A	Select required torque (according to service factor)	Seleziona la coppia desiderata (comprensiva del fattore di servizio)	Max. Drehmoment in Bezug zum Betriebsfaktor	Sélectionner le couple souhaité (comprenant le facteur de service)	Seleccionar el par deseado (incluyendo el factor de servicio)
B	Select output speed	Seleziona la velocità in uscita	Ausgewählte Abtriebsdrehzahl	Sélectionner la vitesse de sortie	Seleccionar la velocidad de salida
C	On the same line of selected geared motor, you can find the gear ratio	Sulla riga corrispondente alla motorizzazione prescelta si può rilevare il rapporto di riduzione	Auf der gleichen Linie wie die ausgewählte Motorleistung steht auch die Getriebeuntersetzung	Sur la ligne correspondante à la motorisation pré-choisie on peut relever le rapport de réduction	En la línea correspondiente al motor preseleccionado es posible encontrar la relación de reducción
D	Select motor flange available (if requested)	Scegli la flangia disponibile (se richiesta)	Erhältliche Motorflansche (auf Anfrage)	Choisir la bride disponible (si elle est demandée)	Seleccionar la brida disponible (sobre pedido)



QUICK SELECTION / Selezione veloce

input speed (n_1) = 1400 min⁻¹

Output Speed n_2 [min ⁻¹]	Ratio i	Motor power P_{1M} [kW]	Output torque M_{2M} [Nm]	Service factor f.s.	Nominal power P_{1R} [kW]	Nominal torque M_{2R} [Nm]	Available B5 motor flanges		Available B14 motor flanges		Dynamic efficiency RD	Tooth Module [mm]	 Ratios code
							A	B	O	P			
							56	63	56	63			
280	5	0.18	5	3.3	0.60	17	B		B-C		82	1.26	09
200	7	0.18	7	2.4	0.44	17	B		B-C		80	1.44	01
140	10	0.18	10	1.8	0.32	17	B		B-C		78	1.44	02
93	15	0.18	13	1.4	0.25	19	B		B-C		73	1.44	03
70	20	0.18	17	1.1	0.20	19	B		B-C		70	1.09	04
47	30	0.12	15	1.4	0.17	21	B		B-C		62	1.44	05
35	40	0.12	19	1.1	0.13	20	B		B-C		57	1.09	06
23	61	0.09	19	1.1	0.10	20	B		B-C		50	0.72	07
17.5	80	0.09	16	1.0	0.06	16	B		B-C		48	0.56	08

A) Motor Flanges Available
Flange Motore Disponibili

B) Supplied with Reduction Bushing
Fornito con Bussola di Riduzione

B) Available on Request without reduction bushing
Disponibile a Richiesta senza Bussola di Riduzione

C) Motor Flange Holes Position
Posizione Fori Flangia Motore

EN Unit **S30** is supplied with synthetic oil, providing "long life" lubrication. For mounting position V5-V6 please contact us. See table 1 for lubrication and recommended quantity. In table 2 please see possible radial loads and axial loads on the gearbox.

I Il riduttore tipo **S30** viene fornito lubrificato a vita con olio sintetico. Per posizioni V5-V6 contattare il ns. servizio tecnico. Vedi tab.1 per oli e quantità consigliati. In tab.2 sono presenti i carichi radiali e assiali applicabili al riduttore.

D Für die Lebensdauerschmierung ist das Getriebe der Größe **S30** mit synthetischem Öl befüllt. Bei Einbaulage V5 oder V6 bitten wir um Rücksprache. In Tabelle 1 ist die Schmiermenge und das empfohlene Schmiermittel angegeben. In Tabelle 2 sind die zulässigen Radial- und Axialbelastungen des Getriebes aufgeführt.

F Le réducteur de type **S30** est fourni lubrifié à vie avec de l'huile synthétique. Concernant les positions V5.V6, contactez notre service d'assistance technique. Voir tableau 1 concernant les huiles et les quantités conseillées. Les charges radiales et axiales applicables au réducteur sont précisées dans le tableau 2.

E El reductor tamaño **S30** se suministra, lubricado de por vida con aceite sintético. Para las posiciones V5 y V6 contactar con nuestro servicio técnico. Ver tabla 1, para cantidades y aceites recomendados. En la tabla 2, se encuentran las cargas radiales y axiales admitidas por el reductor.

LUBRICATION S30 Oil Quantity 0.055 Lt.

AGIP Telium VSF 320

SHELL Omala S4 WE 320

For all details on lubrication and plugs check our website **tab. 1**
Per maggiori dettagli su lubrificazione e tappi olio vedi il nostro sito web

RADIAL AND AXIAL LOADS

Output shaft

Albero di uscita

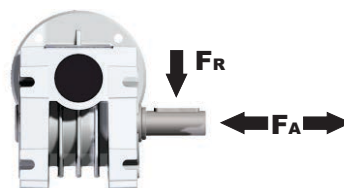

n_2 [min ⁻¹]	FA [N]	FR [N]
200	700	1600
150	700	1600
100	750	1700
75	800	1750
50	850	1800
25	850	1800
15	850	1800

Input shaft

albero in entrata

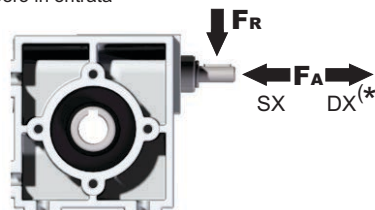

n_1 [min ⁻¹]	FA [N]	FR [N]
1400	20	100

***Strong axial loads in the DX direction are not allowed.**
Non sono consentiti forti carichi assiali con direzione DX

tab. 2

PS30**FB**... Basic wormbox
Riduttore base

Gearbox weight
peso riduttore **1.50 kg**

M. flanges	Kit code	øF	A
56B5	K030.4.041	120	61.5
63B5	K030.4.042	140	62.5
56B14	K030.4.046	80	61.5
63B14	K030.4.045	90	62.5

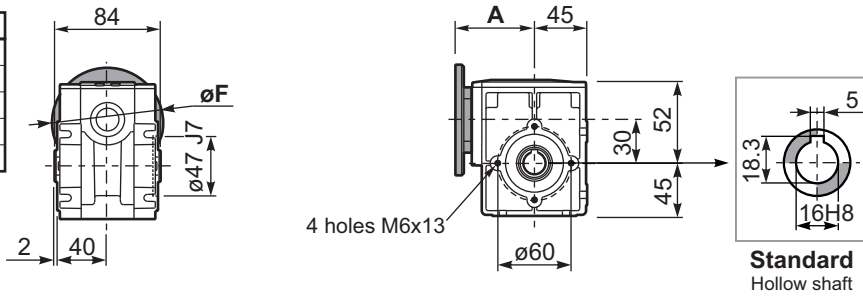

PS30**FM**...C Output flange
Flangia in uscita

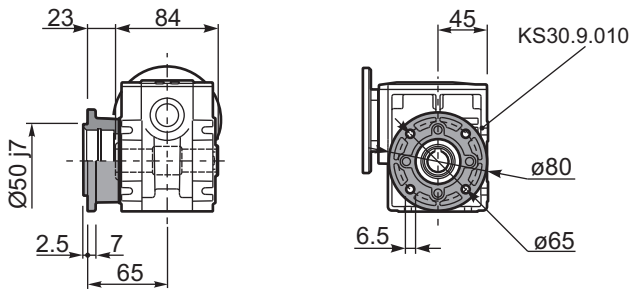

PS30**FB**... Feet
Piedini

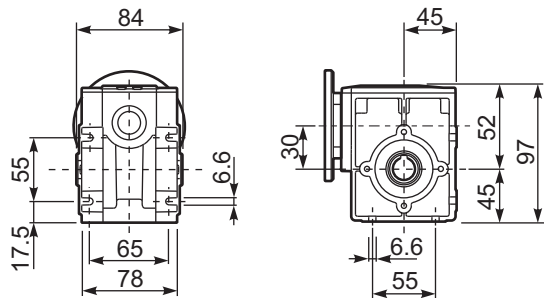

PS30**BR**... Reaction arm
Braccio di reazione

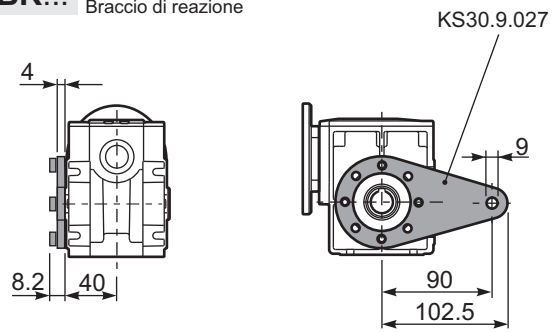

RS30**FB**... Input shaft
Albero in entrata

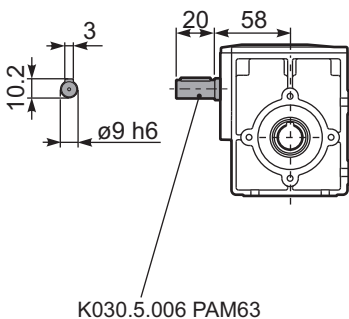

PS30...**S**... Single Shaft
Albero lento semplice

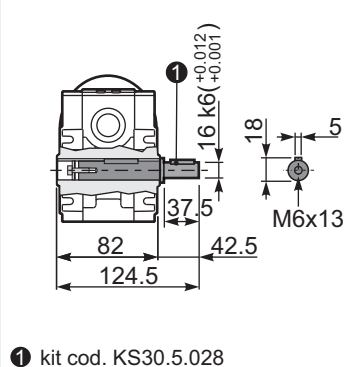

PS30**FM**..R Special Shaft
Albero lento

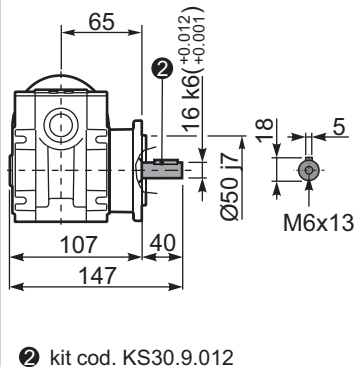

The flange dimensions are the same as FM(KS30.9.010)



QUICK SELECTION / Selezione veloce

input speed (n_1) = 1400 min⁻¹

Output Speed n_2 [min ⁻¹]	Ratio i	Motor power P_{1M} [kW]	Output torque M_{2M} [Nm]	Service factor f.s.	Nominal power P_{1R} [kW]	Nominal torque M_{2R} [Nm]	Available B5 motor flanges		Available B14 motor flanges			Dynamic efficiency RD	Tooth Module [mm]	Ratios code
							B	C	O	P	Q			
							63	71	56	63	71			
200	7	0.37	14	2.2	0.80	30	B		B-C	B-C		80	2.2	01
140	10	0.37	20	1.5	0.57	30	B		B-C	B-C		79	2.2	02
100	14	0.37	27	1.1	0.41	30	B		B-C	B-C		77	2.4	03
67	21	0.37	36	1.2	0.43	41	B		B-C	B-C		67	1.6	04
50	28	0.25	31	1.3	0.33	41	B		B-C	B-C		65	2.5	05
38	37	0.25	40	1.0	0.26	41	B		B-C	B-C		63	1.8	06
30	46	0.25	46	0.9	0.22	41	B		B-C	B-C		59	1.5	07
23	60	0.18	41	1.0	0.18	41	B		B-C	B-C		56	1.2	08
20	70	0.12	31	1.0	0.12	30	B		B-C	B-C		54	1.0	09
13.7	102	0.09	31	1.0	0.09	29	B		B-C	B-C		49	0.72	10

A Motor Flanges Available
Flange Motore Disponibili

B Supplied with Reduction Bushing
Fornito con Bussola di Riduzione

B Available on Request without reduction bushing
Disponibile a Richiesta senza Bussola di Riduzione

C Motor Flange Holes Position
Posizione Fori Flangia Motore

* Power higher than the maximum one which can be supported by the gearbox. Select according to the torque M_{2R}
Potenza superiore a quella massima sopportabile dal riduttore. Selezionare in base al momento torcente M_{2R}

EN Unit S45 is supplied with synthetic oil, providing "long life" lubrication. For mounting position V5-V6 please contact us. See table 1 for lubrication and recommended quantity. In table 2 please see possible radial loads and axial loads on the gearbox.

I Il riduttore tipo S45 viene fornito lubrificato a vita con olio sintetico. Per posizioni V5-V6 contattare il ns. servizio tecnico. Vedi tab.1 per oli e quantità consigliati. In tab.2 sono presenti i carichi radiali e assiali applicabili al riduttore.

D Für die Lebensdauerschmierung ist das Getriebe der Größe S45 mit synthetischem Öl befüllt. Bei Einbaulage V5 oder V6 bitten wir um Rücksprache. In Tabelle 1 ist die Schmiermenge und das empfohlene Schmiermittel angegeben. In Tabelle 2 sind die zulässigen Radial- und Axialbelastungen des Getriebes aufgeführt.

F Le réducteur de type S45 est fourni lubrifié à vie avec de l'huile synthétique. Concernant les positions V5.V6, contactez notre service d'assistance technique. Voir tableau 1 concernant les huiles et les quantités conseillées. Les charges radiales et axiales applicables au réducteur sont précisées dans le tableau 2.

E El reductor tamaño S45 se suministra, lubricado de por vida con aceite sintético. Para las posiciones V5 y V6 contactar con nuestro servicio técnico. Ver tabla 1, para cantidades y aceites recomendados. En la tabla 2, se encuentran las cargas radiales y axiales admitidas por el reductor.

LUBRICATION S45 Oil Quantity 0.20 Lt.

AGIP Telium VSF 320

SHELL Omala S4 WE 320

For all details on lubrication and plugs check our website **tab. 1**
Per maggiori dettagli su lubrificazione e tappi olio vedi il nostro sito web

RADIAL AND AXIAL LOADS

Output shaft
Albero di uscita

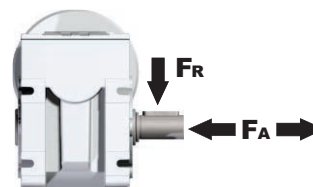

n_2 [min ⁻¹]	FA [N]	FR [N]
200	1000	1900
150	1150	2200
100	1300	2600
75	1300	2800
50	1350	2900
25	1350	2900
15	1400	3000

Input shaft
albero in entrata

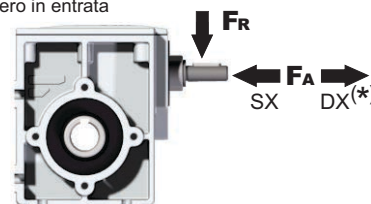

n_1 [min ⁻¹]	FA [N]	FR [N]
1400	42	210

*Strong axial loads in the DX direction are not allowed.
Non sono consentiti forti carichi assiali con direzione DX

tab. 2

PS45**FB**... Basic wormbox
Riduttore base

Gearbox weight
peso riduttore **2.80 kg**

M. flanges	Kit code	øF	A
63B5	K050.4.041	138	78
71B5	K050.4.042	160	75.5
56B14	KC40.4.049	80	75.5
63B14	K050.4.047	90	78
71B14	K050.4.045	105	75.5

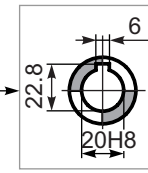
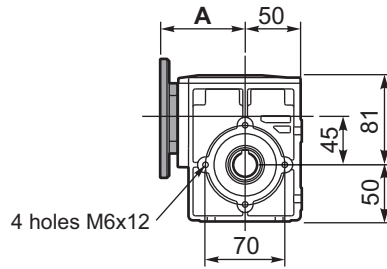
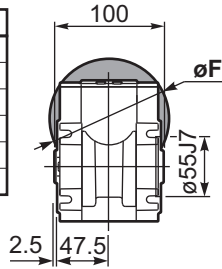

Standard
Hollow shaft

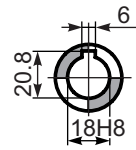

On request
A richiesta

PS45**FM**...C Output flange
Flangia in uscita

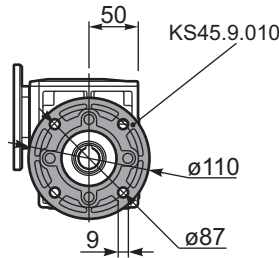
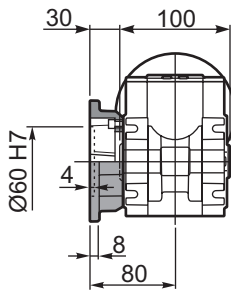

PS45**FN**...C Output flange
Flangia in uscita

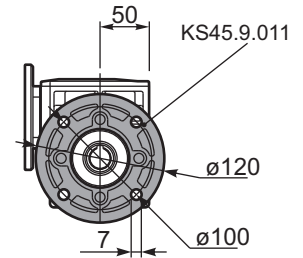
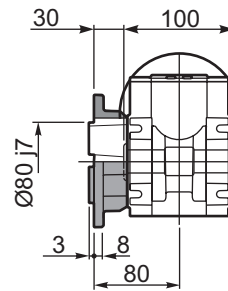

PS45**FB**... Feet
Piedini

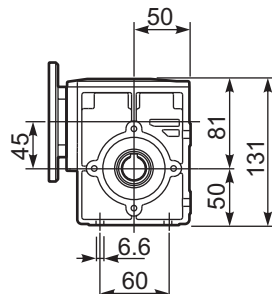
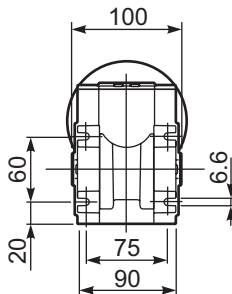

PS45**BR**... Reaction arm
Braccio di reazione

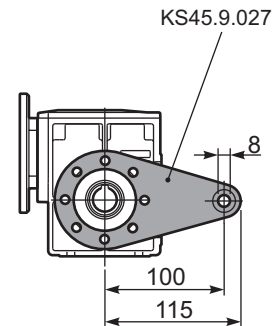
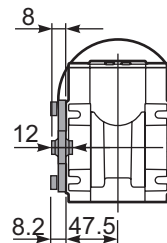

RS45**FB**... Input shaft
Albero in entrata

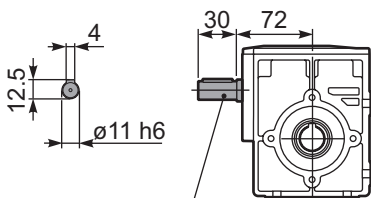

K045.5.006 PAM71

PS45...**S**... Single Shaft
Albero lento semplice

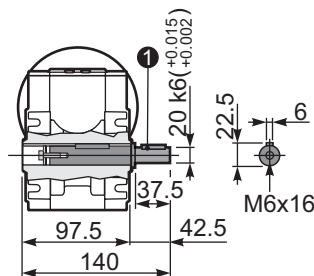

① kit cod. KS45.5.028

PS45**FM**..R Special Shaft
Albero lento

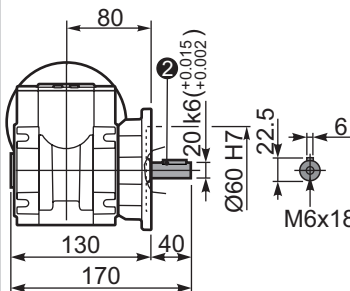

② kit cod. KS45.9.012

The flange dimensions are the same as FM(KS45.9.010)

PS45**FN**..R Special Shaft
Albero lento

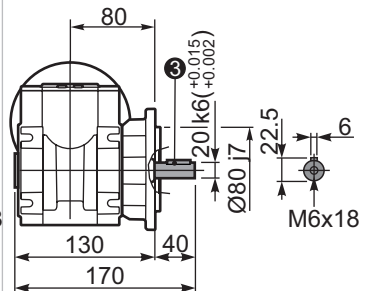

③ kit cod. KS45.9.013

The flange dimensions are the same as FN(KS45.9.011)



QUICK SELECTION / Selezione veloce

input speed (n_1) = 1400 min⁻¹

Output Speed n_2 [min ⁻¹]	Ratio i	Motor power P_{1M} [kW]	Output torque M_{2M} [Nm]	Service factor f.s.	Nominal power P_{1R} [kW]	Nominal torque M_{2R} [Nm]	Available B5 motor flanges			Available B14 motor flanges				Dynamic efficiency RD	Tooth Module [mm]	Ratios code
							B	C	D	O	P	Q	R			
							63	71	80	56	63	71	80			
200	7	0.75	29	1.9	1.5	57	B	B			B-C	B		82	2.5	01
140	10	0.75	41	1.5	1.1	62	B	B			B-C	B		80	2.4	02
100	14	0.75	57	1.2	0.90	68	B	B			B-C	B		79	2.6	03
78	18	0.55	51	1.2	0.67	62	B	B			B-C	B		75	2.0	04
54	26	0.55	67	1.0	0.54	66	B	B			B-C	B		69	2.7	05
47	30	0.55	79	0.9	0.50	72	B	B			B-C	B		70	2.5	12
39	36	0.37	63	1.2	0.43	72	B			B-C	B-C			69	2.1	06
33	43	0.37	72	1.0	0.35	68	B			B-C	B-C			66	1.8	07
23	60	0.25	59	1.0	0.26	62	B			B-C	B-C			58	1.3	08
21	68	0.25	66	0.9	0.22	58	B			B-C	B-C			57	1.2	09
17.5	80	0.18	53	1.1	0.19	57	B			B-C	B-C			54	1.0	10
14	100	0.12	41	1.3	0.15	51	B			B-C	B-C			50	0.8	11

A) Motor Flanges Available
Flange Motore Disponibili

B) Supplied with Reduction Bushing
Fornito con Bussola di Riduzione

B) Available on Request without reduction bushing
Disponibile a Richiesta senza Bussola di Riduzione

C) Motor Flange Holes Position
Posizione Fori Flangia Motore

EN Unit **S50** is supplied with synthetic oil, providing "long life" lubrication. For mounting position V5-V6 please contact us. See table 1 for lubrication and recommended quantity. In table 2 please see possible radial loads and axial loads on the gearbox.

I Il riduttore tipo **S50** viene fornito lubrificato a vita con olio sintetico. Per posizioni V5-V6 contattare il ns. servizio tecnico. Vedi tab.1 per oli e quantità consigliati. In tab.2 sono presenti i carichi radiali e assiali applicabili al riduttore.

D Für die Lebensdauerschmierung ist das Getriebe der Größe **S50** mit synthetischem Öl befüllt. Bei Einbaulage V5 oder V6 bitten wir um Rücksprache. In Tabelle 1 ist die Schmiermenge und das empfohlene Schmiermittel angegeben. In Tabelle 2 sind die zulässigen Radial - und Axialbelastungen des Getriebes aufgeführt.

F Le réducteur de type **S50** est fourni lubrifié à vie avec de l'huile synthétique. Concernant les positions V5.V6, contactez notre service d'assistance technique. Voir tableau 1 concernant les huiles et les quantités conseillées. Les charges radiales et axiales applicables au réducteur sont précisées dans le tableau 2.

E El reductor tamaño **S50** se suministra, lubricado de por vida con aceite sintético. Para las posiciones V5 y V6 contactar con nuestro servicio técnico. Ver tabla 1, para cantidades y aceites recomendados. En la tabla 2, se encuentran las cargas radiales y axiales admitidas por el reductor.

LUBRICATION S50 Oil Quantity 0.25 Lt.

AGIP Telium VSF 320

SHELL Omala S4 WE 320

For all details on lubrication and plugs check our website **tab. 1**
Per maggiori dettagli su lubrificazione e tappi olio vedi il nostro sito web

RADIAL AND AXIAL LOADS

Output shaft

Albero di uscita

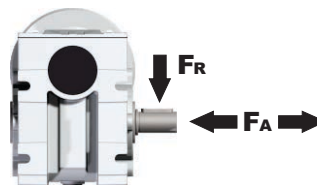

n_2 [min ⁻¹]	FA [N]	FR [N]
200	1350	2250
150	1500	2500
100	1650	2750
75	1650	2750
50	1700	2900
25	1700	2900
15	1700	3000

Input shaft

albero in entrata

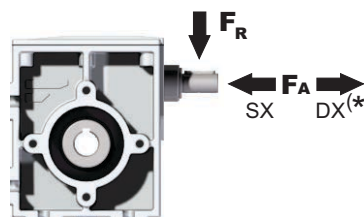

n_1 [min ⁻¹]	FA [N]	FR [N]
1400	76	380

*Strong axial loads in the DX direction are not allowed.
Non sono consentiti forti carichi assiali con direzione DX

tab. 2

PS50FB... Basic wormbox
Riduttore base

Gearbox weight
peso riduttore **4.40 kg**

M. flanges	Kit code	øF	A
63B5	K050.4.041	138	82.5
71B5	K050.4.042	160	80
80B5	K050.4.043	200	80.5
56B14	KC40.4.049	80	80
63B14	K050.4.047	90	82.5
71B14	K050.4.045	105	80
80B14	K050.4.046	120	80.5

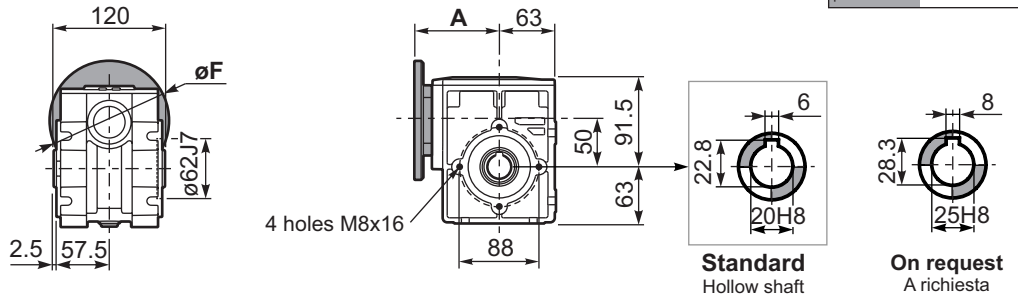

PS50FM...C Output flange
Flangia in uscita

PS50FN...C Output flange
Flangia in uscita

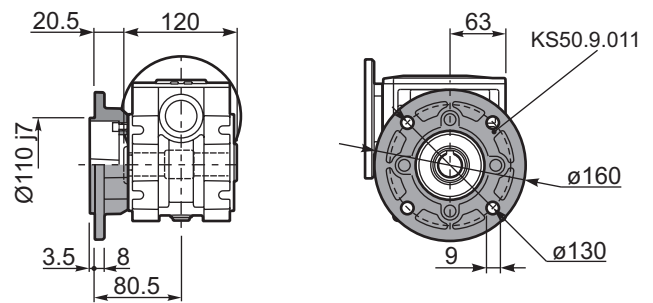
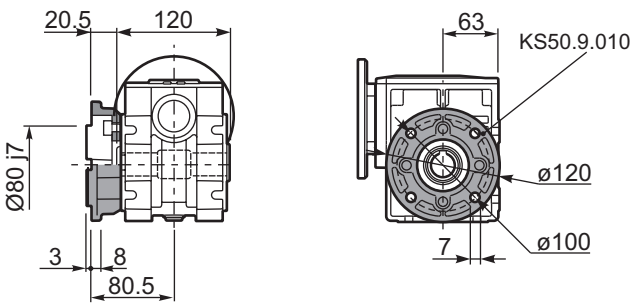

PS50FB... Feet
Piedini

PS50BR... Reaction arm
Braccio di reazione

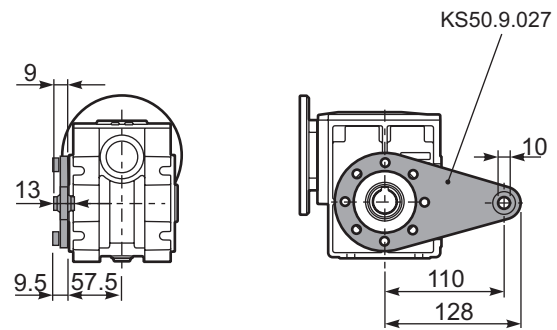
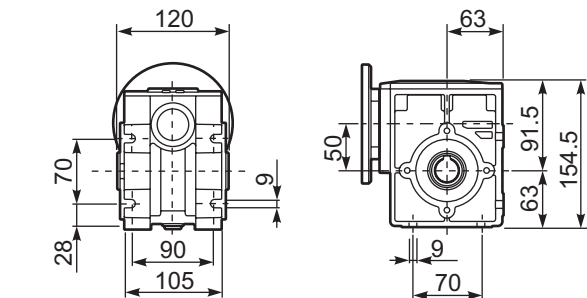

RS50FB... Input shaft
Albero in entrata

PS50....S... Single Shaft
Albero lento semplice

PS50FM..R Special Shaft
Albero lento

PS50FN..R Special Shaft
Albero lento

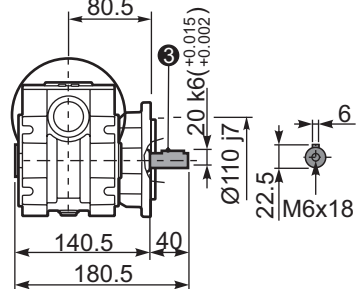
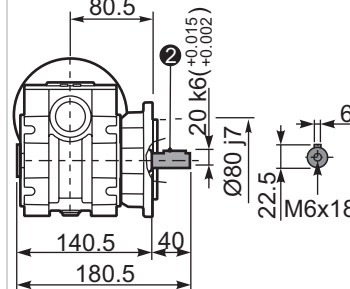
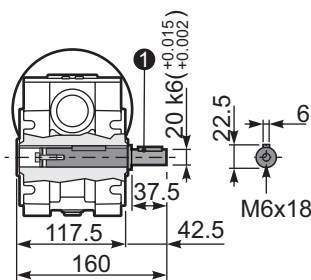
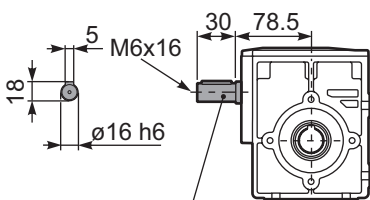

K050.5.006 PAM71
K050.5.007 PAM80

① kit cod. KS50.5.028

② kit cod. KS50.9.012

③ kit cod. KS50.9.013

The flange dimensions are the same as FM(KS50.9.010)

The flange dimensions are the same as FN(KS50.9.011)



QUICK SELECTION / Selezione veloce

input speed (n_1) = 1400 min⁻¹

Output Speed n_2 [min ⁻¹]	Ratio i	Motor power P_{1M} [kW]	Output torque M_{2M} [Nm]	Service factor f.s.	Nominal power P_{1R} [kW]	Nominal torque M_{2R} [Nm]	Available B5 motor flanges				Available B14 motor flanges			Dynamic efficiency RD	Tooth Module [mm]	Ratios code 	
							B	C	D	E	Q	R	T				
							63	71	80	90	71	80	90				
200	7	1.8	71	1.8	3.2	125		B	B			B-C	B-C		83	3.1	01
140	10	1.8	99	1.4	2.4	134		B	B			B-C	B-C		81	3.1	02
93	15	1.5	121	1.1	1.7	138		B	B			B-C	B-C		79	3.1	03
74	19	1.1	111	1.2	1.4	138		B	B			B-C	B-C		78	2.6	04
58	24	1.1	135	1.0	1.2	142		B	B			B-C	B-C		75	2.0	05
47	30	1.1	167	0.9	0.96	146		B	B			B-C	B-C		74	3.2	06
39	36	0.75	125	1.2	0.88	147		B	B	B		B-C	B-C		68	2.7	07
31	45	0.55	111	1.2	0.67	135	B	B				B-C	C		66	2.1	08
23	60	0.55	140	0.9	0.51	130	B	B				B-C	C		62	1.6	12
21	67	0.55	151	0.8	0.45	124	B	B				B-C	C		60	1.5	09
17.5	80	0.37	115	1.0	0.38	119	B	B				B-C	C		57	1.3	10
14.9	94	0.37	123	1.0	0.36	119	B	B				B-C	C		52	1.1	11

Motor Flanges Available
Flange Motore Disponibili

B) Supplied with Reduction Bushing
Fornito con Bussola di Riduzione

B) Available on Request without reduction bushing
Disponibile a Richiesta senza Bussola di Riduzione

C) Motor Flange Holes Position
Posizione Fori Flangia Motore

EN Unit **S63** is supplied with synthetic oil, providing "long life" lubrication. For mounting position V5-V6 please contact us. See table 1 for lubrication and recommended quantity. In table 2 please see possible radial loads and axial loads on the gearbox.

I Il riduttore tipo **S63** viene fornito lubrificato a vita con olio sintetico. Per posizioni V5-V6 contattare il ns. servizio tecnico. Vedi tab.1 per oli e quantità consigliati. In tab.2 sono presenti i carichi radiali e assiali applicabili al riduttore.

D Für die Lebensdauerschmierung ist das Getriebe der Größe **S63** mit synthetischem Öl befüllt. Bei Einbaulage V5 oder V6 bitten wir um Rücksprache. In Tabelle 1 ist die Schmiermenge und das empfohlene Schmiermittel angegeben. In Tabelle 2 sind die zulässigen Radial- und Axialbelastungen des Getriebes aufgeführt.

F Le réducteur de type **S63** est fourni lubrifié à vie avec de l'huile synthétique. Concernant les positions V5.V6, contactez notre service d'assistance technique. Voir tableau 1 concernant les huiles et les quantités conseillées. Les charges radiales et axiales applicables au réducteur sont précisées dans le tableau 2.

E El reductor tamaño **S63** se suministra, lubricado de por vida con aceite sintético. Para las posiciones V5 y V6 contactar con nuestro servicio técnico. Ver tabla 1, para cantidades y aceites recomendados. En la tabla 2, se encuentran las cargas radiales y axiales admitidas por el reductor.

LUBRICATION S63 Oil Quantity 0.50 Lt.

AGIP Telium VSF 320

SHELL Omala S4 WE 320

For all details on lubrication and plugs check our website **tab. 1**
Per maggiori dettagli su lubrificazione e tappi olio vedi il nostro sito web

RADIAL AND AXIAL LOADS

Output shaft

Albero di uscita

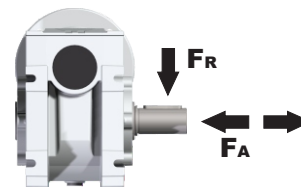

n_2 [min ⁻¹]	FA [N]	FR [N]
200	2000	3250
150	2300	4100
100	2850	4600
75	3400	5500
50	3600	6000
25	3600	6000
15	3600	6200

Input shaft

albero in entrata

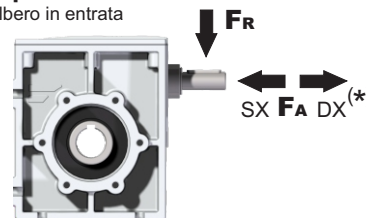

n_1 [min ⁻¹]	FA [N]	FR [N]
1400	90	450

***Strong axial loads in the DX direction are not allowed.**
Non sono consentiti forti carichi assiali con direzione DX

tab. 2

PS63**FB**... Basic wormbox
Riduttore base

Gearbox weight
peso riduttore **7.50 kg**

M. flanges	Kit code	øF	A
63B5	K063.4.041	140	99.5
71B5	K063.4.042	160	97.5
80/90B5	K063.4.043	200	99.5
71B14	K063.4.047	105	97.5
80B14	K063.4.046	120	99.5
90B14	K063.4.041	140	99.5

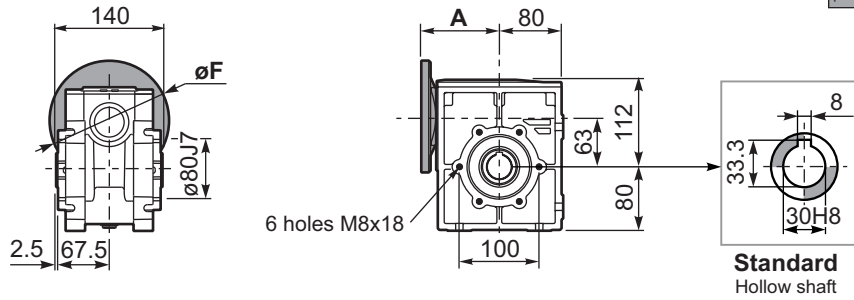

PS63**FM**..C Output flange
Flangia in uscita

PS63**FN**..C Output flange
Flangia in uscita

3

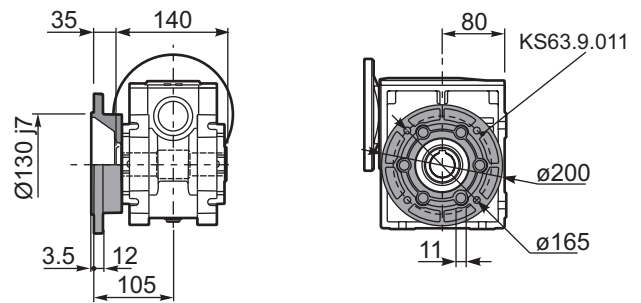
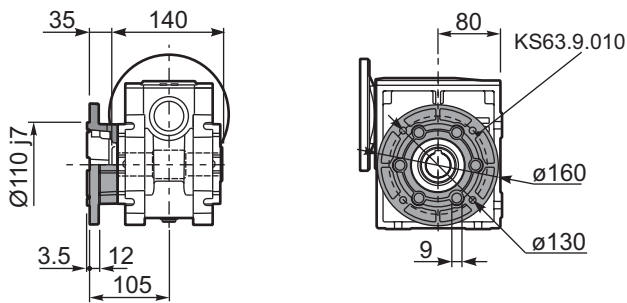

PS63**FB**... Feet
Piedini

PS63**BR**... Reaction arm
Braccio di reazione

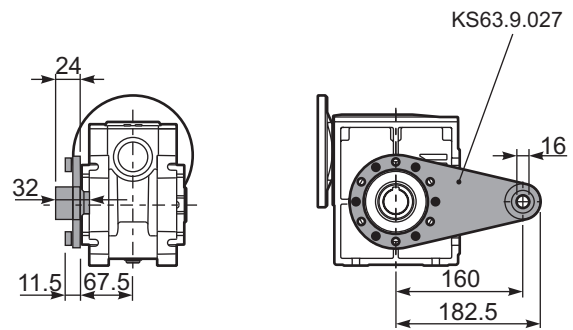
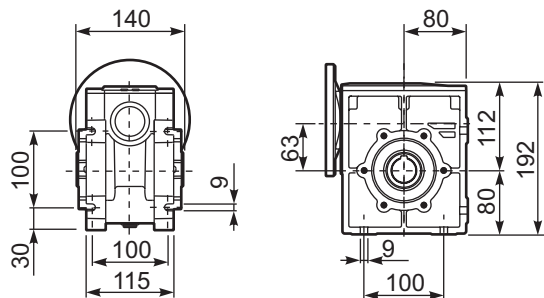

RS63FB... Input shaft
Albero in entrata

PS63.....**S**... Single Shaft
Albero lento semplice

PS63**FM**..R Special Shaft
Albero lento

PS63**FN**..R Special Shaft
Albero lento

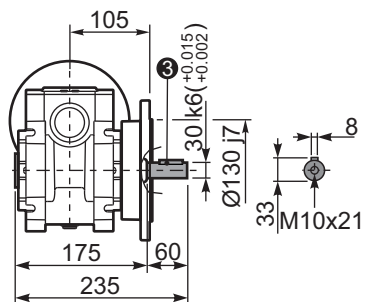
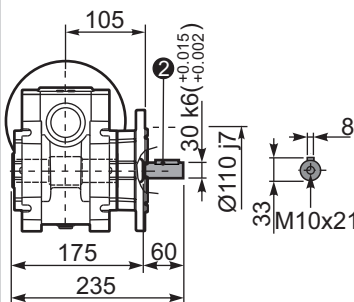
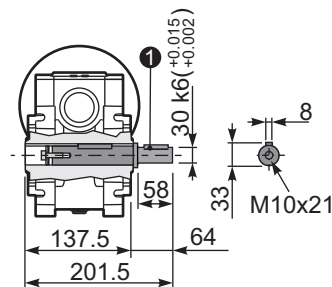
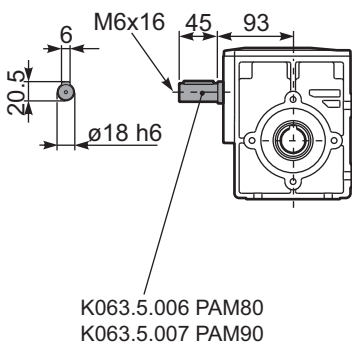

1 kit cod. KS63.5.028

2 kit cod. KS63.9.012

3 kit cod. KS63.9.013

The flange dimensions are the same as FM(KS63.9.010)

The flange dimensions are the same as FN(KS63.9.011)

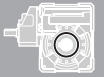

QUICK SELECTION / Selezione veloce

input speed (n_1) = 1400 min⁻¹

Output Speed n_2 [min ⁻¹]	Ratio i	Motor power P_{1M} [kW]	Output torque M_{2M} [Nm]	Service factor f.s.	Nominal power P_{1R} [kW]	Nominal torque M_{2R} [Nm]	Available B5 motor flanges			Available B14 motor flanges		Dynamic efficiency RD	Tooth Module [mm]	Ratios code
							A	B	C	P	Q			
							56	63	71	63	71			
47	30.1	0.25	38	1.4	0.36	55				C		74	2.2	01
33	43.0	0.25	53	1.0	0.26	55				C		72	2.2	02
23	60.2	0.25	62	0.9	0.22	55				C		60	2.4	03
15.5	90.3	0.12	42	1.3	0.16	55				C		57	1.6	04
11.6	120	0.12	52	1.1	0.13	55				C		53	2.5	05
8.8	159	0.12	64	0.9	0.10	55				C		49	1.8	06
7.1	198	0.12*	55	<0.8	0.09	55				C		47	1.5	07
5.4	258	0.12*	55	<0.8	0.07	55				C		45	1.2	08
4.7	301	0.12*	39	<0.8	0.05	39				C		40	1.0	09
3.2	439	0.12*	39	<0.8	0.04	39				C		36	0.72	10

A) Motor Flanges Available
Flange Motore Disponibili

B) Supplied with Reduction Bushing
Fornito con Bussola di Riduzione

Available on Request without reduction bushing
Disponibile a Richiesta senza Bussola di Riduzione

C) Motor Flange Holes Position
Posizione Fori Flangia Motore

* Power higher than the maximum one which can be supported by the gearbox. Select according to the torque M_{2R}
Potenza superiore a quella massima sopportabile dal riduttore. Selezionare in base al momento torcente M_{2R}

EN Unit **PS4** is supplied with synthetic oil, providing "long life" lubrication. For mounting position V5-V6 please contact us. See table 1 for lubrication and recommended quantity. In table 2 please see possible radial loads and axial loads on the gearbox.

I Il riduttore tipo **PS4** viene fornito lubrificato a vita con olio sintetico. Per posizioni V5-V6 contattare il ns. servizio tecnico. Vedi tab.1 per oli e quantità consigliati. In tab.2 sono presenti i carichi radiali e assiali applicabili al riduttore.

D Für die Lebensdauerschmierung ist das Getriebe der Größe **PS4** mit synthetischem Öl befüllt. Bei Einbaulage V5 oder V6 bitten wir um Rücksprache. In Tabelle 1 ist die Schmiermenge und das empfohlene Schmiermittel angegeben. In Tabelle 2 sind die zulässigen Radial- und Axialbelastungen des Getriebes aufgeführt.

F Le réducteur de type **PS4** est fourni lubrifié à vie avec de l'huile synthétique. Concernant les positions V5.V6, contactez notre service d'assistance technique. Voir tableau 1 concernant les huiles et les quantités conseillées. Les charges radiales et axiales applicables au réducteur sont précisées dans le tableau 2.

E El reductor tamaño **PS4** se suministra, lubricado de por vida con aceite sintético. Para las posiciones V5 y V6 contactar con nuestro servicio técnico. Ver tabla 1, para cantidades y aceites recomendados. En la tabla 2, se encuentran las cargas radiales y axiales admitidas por el reductor.

LUBRICATION PS5 Oil
Common lubrication 0.25 l (A + B) except V5 mounting position which is 0.4 l (A + B).

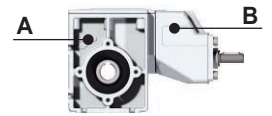

AGIP Telium VSF 320

SHELL Omala S4 WE 320

For all details on lubrication and plugs check our website **tab. 1**
Per maggiori dettagli su lubrificazione e tappi olio vedi il nostro sito web

RADIAL AND AXIAL LOADS

Output shaft
Albero di uscita

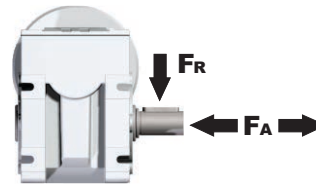

n_2 [min ⁻¹]	FA [N]	FR [N]
200	1000	1900
150	1150	2200
100	1300	2600
75	1300	2800
50	1350	2900
25	1350	2900
15	1400	3000

Input shaft
albero in entrata

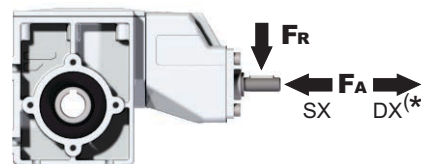

n_1 [min ⁻¹]	FA [N]	FR [N]
1400	44	220

*Strong axial loads in the DX direction are not allowed.
Non sono consentiti forti carichi assiali con direzione DX

tab. 2

PPS4FB... Basic wormbox
Riduttore base

Gearbox weight
peso riduttore **3.80 kg**

M. flanges	Kit code	øF	A
56B5	K050.4.046	120	141.5
63B5	K050.4.041	138	143.5
71B5	K050.4.042	160	141
63B14	K050.4.047	90	143.5
71B14	K050.4.045	105	141

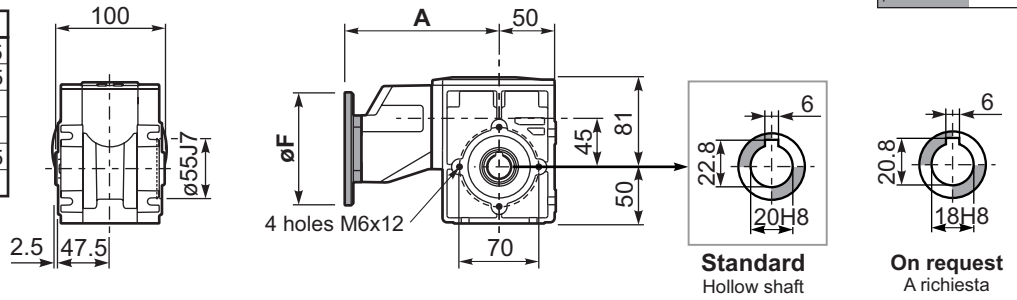

PPS4FM...C Output flange
Flangia in uscita

PPS4FN...C Output flange
Flangia in uscita

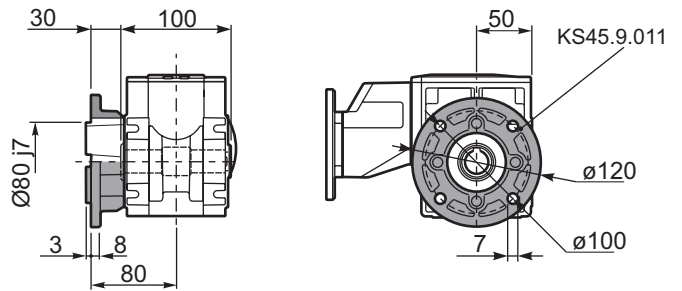
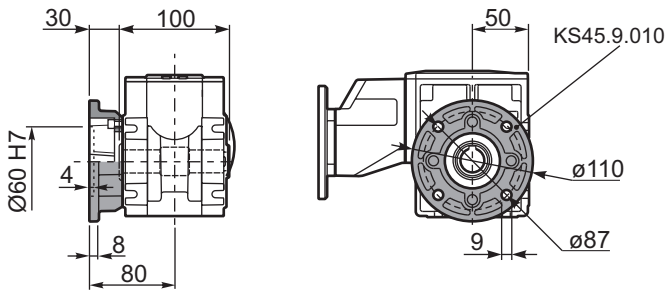

PPS4FB... Feet
Piedini

PPS4BR... Reaction arm
Braccio di reazione

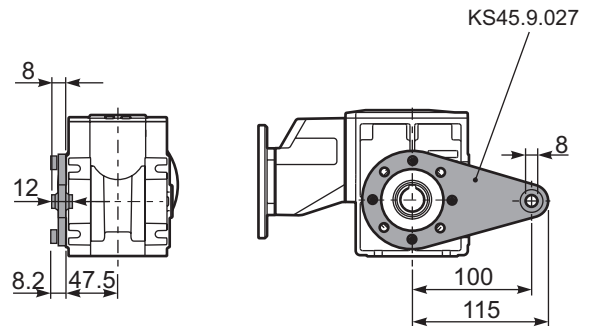
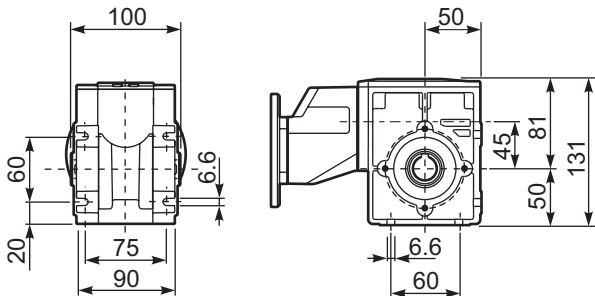

RPS4FB... Input shaft
Albero in entrata

PPS4.....S... Single Shaft
Albero lento semplice

PPS4FM..R Special Shaft
Albero lento

PPS4FN..R Special Shaft
Albero lento

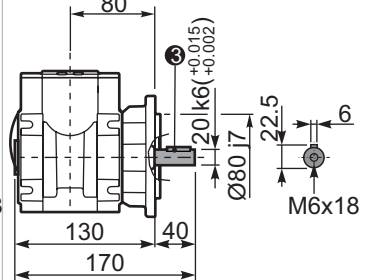
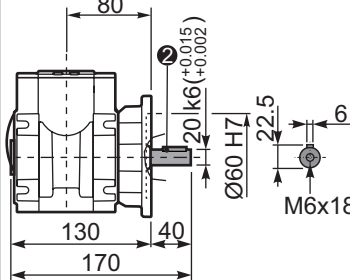
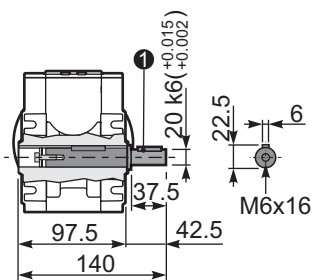
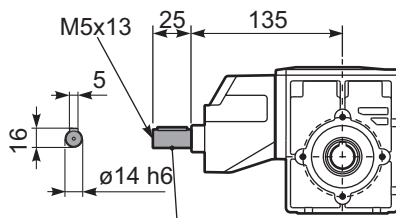

C35.5.061

① kit cod. KS45.5.028

② kit cod. KS45.9.012

③ kit cod. KS45.9.013

The flange dimensions are the same as FM(KS45.9.010)

The flange dimensions are the same as FN(KS45.9.011)

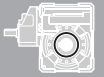

QUICK SELECTION / Selezione veloce

input speed (n_1) = 1400 min⁻¹

Output Speed n_2 [min ⁻¹]	Ratio i	Motor power P_{1M} [kW]	Output torque M_{2M} [Nm]	Service factor f.s.	Nominal power P_{1R} [kW]	Nominal torque M_{2R} [Nm]	Available B5 motor flanges			Available B14 motor flanges		Dynamic efficiency RD	Tooth Module [mm]	Ratios code
							A	B	C	P	Q			
							56	63	71	63	71			
47	30.1	0.37	58	1.3	0.49	77				C		76	2.5	01
33	43.0	0.25	55	1.4	0.35	77				C		75	2.4	02
23	60.2	0.25	71	1.1	0.27	77				C		69	2.6	03
18.1	77.4	0.25	81	1.1	0.27	88				C		61	2.0	04
12.5	112	0.18	84	1.1	0.19	88				C		61	2.7	05
9.0	155	0.12	71	1.2	0.15	88				C		56	2.1	06
7.6	185	0.12	74	1.0	0.12	77				C		49	1.8	07
5.4	258	0.12*	77	<0.8	0.09	77				C		47	1.3	08
4.8	292	0.12*	66	<0.8	0.08	66				C		44	1.2	09
4.1	344	0.12*	44	<0.8	0.05	44				C		40	1.0	10
3.3	430	0.12*	44	<0.8	0.04	44				C		36	0.8	11

A) Motor Flanges Available
Flange Motore Disponibili

B) Supplied with Reduction Bushing
Fornito con Bussola di Riduzione

B) Available on Request without reduction bushing
Disponibile a Richiesta senza Bussola di Riduzione

C) Motor Flange Holes Position
Posizione Fori Flangia Motore

* Power higher than the maximum one which can be supported by the gearbox. Select according to the torque M_{2R}
Potenza superiore a quella massima sopportabile dal riduttore. Selezionare in base al momento torcente M_{2R}

EN Unit **PS5** is supplied with synthetic oil, providing "long life" lubrication. For mounting position V5-V6 please contact us. See table 1 for lubrication and recommended quantity. In table 2 please see possible radial loads and axial loads on the gearbox.

I Il riduttore tipo **PS5** viene fornito lubrificato a vita con olio sintetico. Per posizioni V5-V6 contattare il ns. servizio tecnico. Vedi tab.1 per oli e quantità consigliati. In tab.2 sono presenti i carichi radiali e assiali applicabili al riduttore.

D Für die Lebensdauerschmierung ist das Getriebe der Größe **PS5** mit synthetischem Öl befüllt. Bei Einbaulage V5 oder V6 bitten wir um Rücksprache. In Tabelle 1 ist die Schmiermenge und das empfohlene Schmiermittel angegeben. In Tabelle 2 sind die zulässigen Radial- und Axialbelastungen des Getriebes aufgeführt.

F Le réducteur de type **PS5** est fourni lubrifié à vie avec de l'huile synthétique. Concernant les positions V5.V6, contactez notre service d'assistance technique. Voir tableau 1 concernant les huiles et les quantités conseillées. Les charges radiales et axiales applicables au réducteur sont précisées dans le tableau 2.

E El reductor tamaño **PS5** se suministra, lubricado de por vida con aceite sintético. Para las posiciones V5 y V6 contactar con nuestro servicio técnico. Ver tabla 1, para cantidades y aceites recomendados. En la tabla 2, se encuentran las cargas radiales y axiales admitidas por el reductor.

LUBRICATION PS5 Oil
Common lubrication 0.32 l (A + B)
except V5 mounting position
which is 0.52 l (A + B).

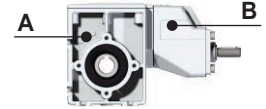

AGIP Telium VSF 320

SHELL Omala S4 WE 320

For all details on lubrication and plugs check our website **tab. 1**
Per maggiori dettagli su lubrificazione e tappi olio vedi il nostro sito web

RADIAL AND AXIAL LOADS

Output shaft
Albero di uscita

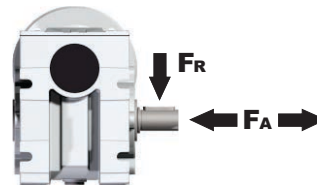

n_2 [min ⁻¹]	FA [N]	FR [N]
200	1350	2250
150	1500	2500
100	1650	2750
75	1650	2750
50	1700	2900
25	1700	2900
15	1700	3000

Input shaft
albero in entrata

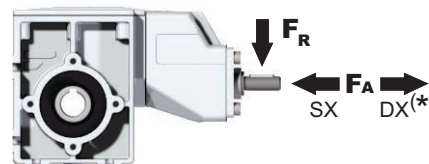

n_1 [min ⁻¹]	FA [N]	FR [N]
1400	44	220

*Strong axial loads in the DX direction are not allowed.
Non sono consentiti forti carichi assiali con direzione DX

tab. 2

PPS5FB... Basic wormbox
Riduttore base

Gearbox weight
peso riduttore **5.40 Lt.**

M. flanges	Kit code	øF	A
56B5	K050.4.046	120	146
63B5	K050.4.041	138	148
71B5	K050.4.042	160	145.5
63B14	K050.4.047	90	148
71B14	K050.4.045	105	145.5

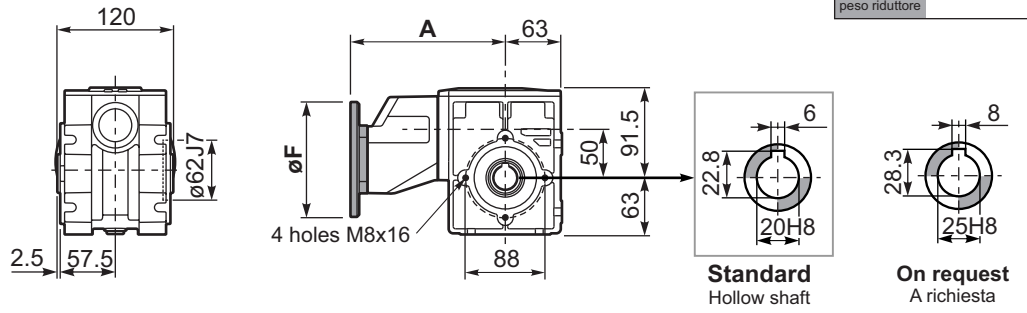

PPS5FM...C Output flange
Flangia in uscita

PPS5FN...C Output flange
Flangia in uscita

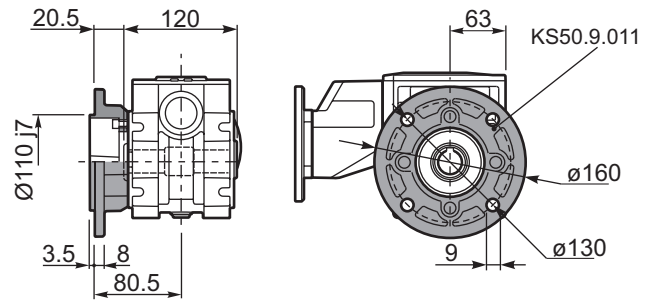
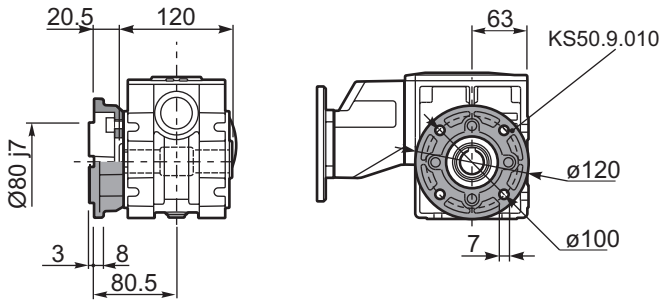

PPS5FB... Feet
Piedini

PPS5BR... Reaction arm
Braccio di reazione

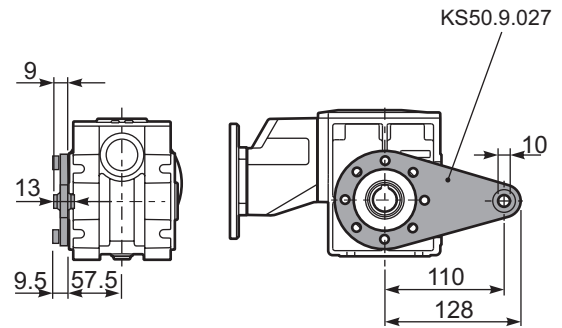
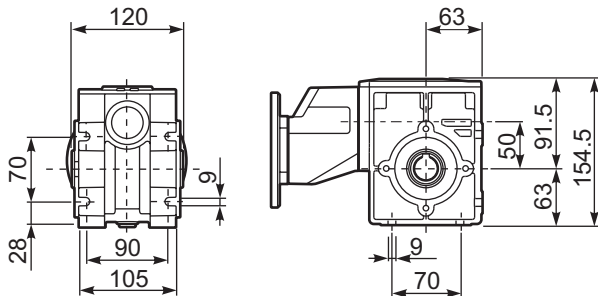

RPS5FB... Input shaft
Albero in entrata

PPS5...S... Single Shaft
Albero lento semplice

PPS5FM..R Special Shaft
Albero lento

PPS5FN..R Special Shaft
Albero lento

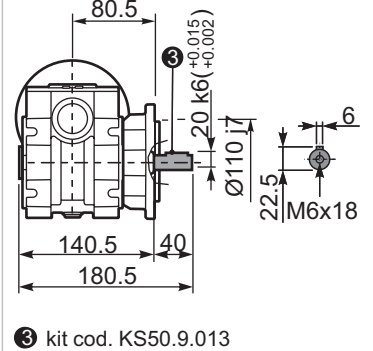
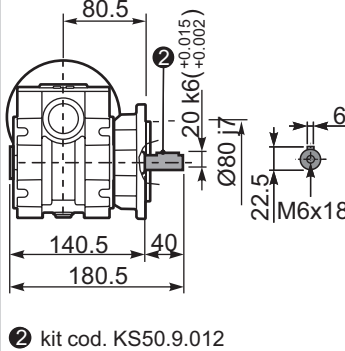
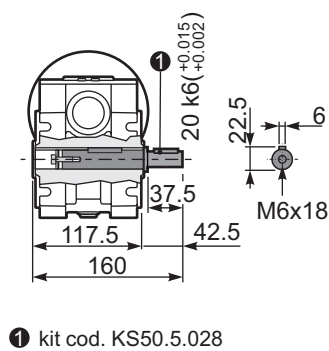
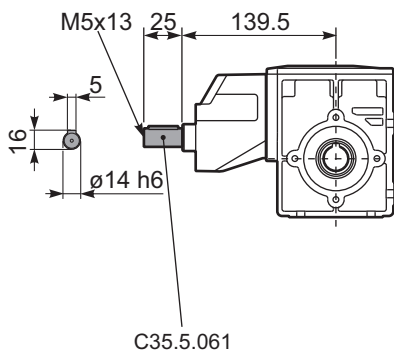

The flange dimensions are the same as FM(KS50.9.010)

The flange dimensions are the same as FN(KS50.9.011)



QUICK SELECTION / Selezione veloce

input speed (n_1) = 1400 min⁻¹

	Output Speed n_2 [min ⁻¹]	Ratio i	Motor power P_{1M} [kW]	Output torque M_{2M} [Nm]	Service factor f.s.	Nominal power P_{1R} [kW]	Nominal torque M_{2R} [Nm]	Available B5 motor flanges				Available B14 motor flanges				Dynamic efficiency RD	Tooth Module [mm]	Ratios code
								B	C	D	E	P	Q	R	T			
								63	71	80	90	63	71	80	90			
IEC 90 - 80 - 71	47	29.9	0.75	113	1.5	1.1	165						C	C		74	2.6	01
	37	37.7	0.75	141	1.2	0.88	165						C	C		73	2.0	02
	30	47.1	0.75	169	1.1	0.83	187						C	C		70	3.2	03
	25	56.6	0.55	136	1.4	0.76	187						C	C		64	2.7	04
	19.8	70.7	0.55	164	1.1	0.63	187						C	C		62	2.1	05
	15.9	87.8	0.37	162	1.2	0.43	187						C	C		73	2.6	06
	12.6	111.0	0.37	199	0.9	0.35	187						C	C		71	2.0	07
IEC 71 - 63	10.1	139	0.37	234	0.8	0.30	187						C			67	3.2	08
	8.4	166	0.25	173	1.1	0.27	187						C			61	2.7	09
	6.7	208	0.18	151	1.1	0.20	165						C			59	2.1	10
	4.5	310	0.12	129	1.3	0.15	165						C			51	1.5	11
	3.8	370	0.12	145	1.1	0.14	165						C			48	1.3	12
	3.2	434	0.12	149	0.9	0.11	138						C			42	1.1	13

A Motor Flanges Available
Flange Motore Disponibili

B Supplied with Reduction Bushing
Fornito con Bussola di Riduzione

B Available on Request without reduction bushing
Disponibile a Richiesta senza Bussola di Riduzione

C Motor Flange Holes Position
Posizione Fori Flangia Motore

EN Unit **PS6** is supplied with synthetic oil, providing "long life" lubrication. For mounting position V5-V6 please contact us. See table 1 for lubrication and recommended quantity. In table 2 please see possible radial loads and axial loads on the gearbox.

I Il riduttore tipo **PS6** viene fornito lubrificato a vita con olio sintetico. Per posizioni V5-V6 contattare il ns. servizio tecnico. Vedi tab.1 per oli e quantità consigliati. In tab.2 sono presenti i carichi radiali e assiali applicabili al riduttore.

D Für die Lebensdauerschmierung ist das Getriebe der Größe **PS6** mit synthetischem Öl befüllt. Bei Einbaulage V5 oder V6 bitten wir um Rücksprache. In Tabelle 1 ist die Schmiermenge und das empfohlene Schmiermittel angegeben. In Tabelle 2 sind die zulässigen Radial- und Axialbelastungen des Getriebes aufgeführt.

F Le réducteur de type **PS6** est fourni lubrifié à vie avec de l'huile synthétique. Concernant les positions V5.V6, contactez notre service d'assistance technique. Voir tableau 1 concernant les huiles et les quantités conseillées. Les charges radiales et axiales applicables au réducteur sont précisées dans le tableau 2.

E El reductor tamaño **PS6** se suministra, lubricado de por vida con aceite sintético. Para las posiciones V5 y V6 contactar con nuestro servicio técnico. Ver tabla 1, para cantidades y aceites recomendados. En la tabla 2, se encuentran las cargas radiales y axiales admitidas por el reductor.

LUBRICATION P63 Oil

For B3-V5-V6 separate lubrication for A (0.50 l) B (0.08 l) , for B6-B7-B8 common lubrication 0.70 l (A + B).



AGIP Telium VSF 320

SHELL Omala S4 WE 320

For all details on lubrication and plugs check our website **tab. 1**
Per maggiori dettagli su lubrificazione e tappi olio vedi il nostro sito web

RADIAL AND AXIAL LOADS

Output shaft

Albero di uscita

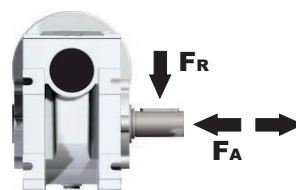

n_2 [min ⁻¹]	FA [N]	FR [N]
200	2000	3250
150	2300	4100
100	2850	4600
75	3400	5500
50	3600	6000
25	3600	6000
15	3600	6200

Input shaft

albero in entrata

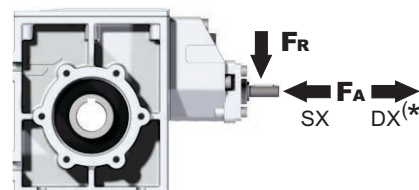

n_1 [min ⁻¹]	FA [N]	FR [N]
1400	61	305

*Strong axial loads in the DX direction are not allowed.
Non sono consentiti forti carichi assiali con direzione DX

tab. 2

PPS6FB... Basic wormbox
Riduttore base

Gearbox weight peso riduttore	29.9+111	139+434
	9.60	9.10
	Kg	Kg

M.flange	Kit code	øF	A	
29.9+111	71B5	K063.4.042	160	176.5
	80/90B5	K063.4.043	200	178.5
	71B14	K063.4.047	105	176.5
	80B14	K063.4.046	120	178.5
	90B14	K063.4.041	140	178.5
139+434	63B5	K050.4.041	138	162.5
	71B5	K050.4.042	160	160
	63B14	K050.4.047	90	162.5
	71B14	K050.4.045	105	160

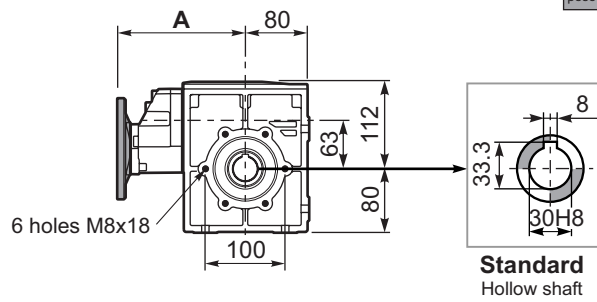
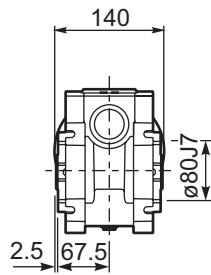

PPS6FM... Output flange
Flangia in uscita

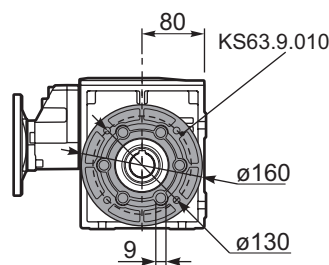
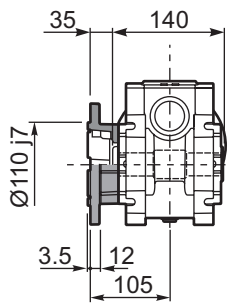

PPS6FN... Output flange
Flangia in uscita

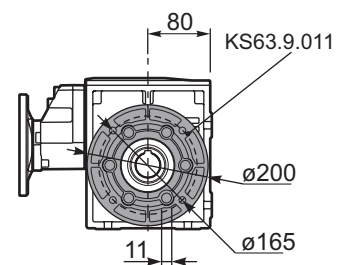
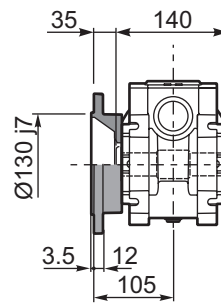

PPS6FB... Feet
Piedini

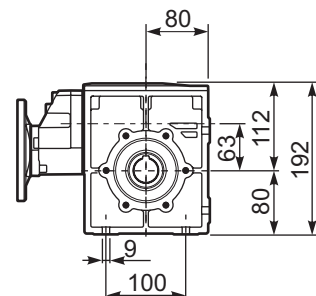
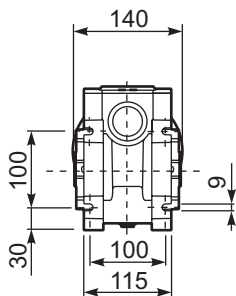

PPS6BR... Reaction arm
Braccio di reazione

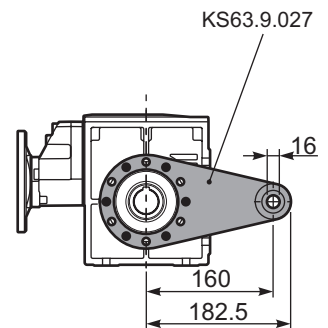
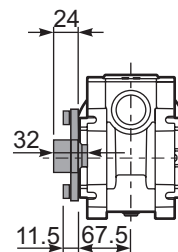

RPS6FB... Input shaft
Albero in entrata

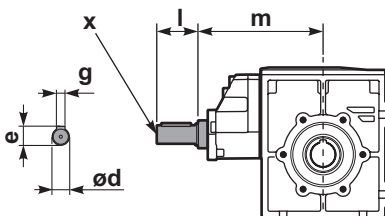

	29.9+111	139+434
ød	19 h6	14 h6
e	21.5	16
g	6	5
l	35	25
m	169.4	154.2
x	M6x16	M5x13
	C40.5.062	C35.5.061

PPS6....S... Single Shaft
Albero lento semplice

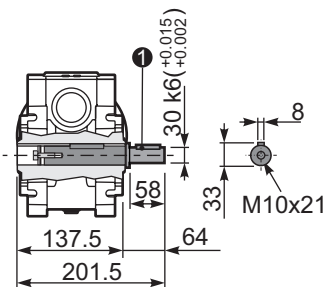

① kit cod. KS63.5.028

PPS6FM..R Special Shaft
Albero lento

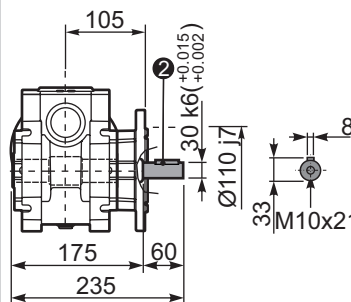

② kit cod. KS63.9.012

The flange dimensions are the same as FM(KS63.9.010)

PPS6FN..R Special Shaft
Albero lento

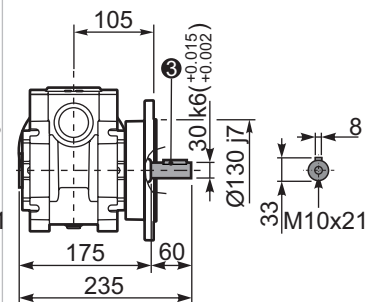

③ kit cod. KS63.9.013

The flange dimensions are the same as FN(KS63.9.011)

Aluminum one step gearboxes

A modular and compact product

4

Alloy housing

Is vacuum impregnated (MIL-STD 276) for protection and sealing. No secondary finish required but readily accepts paint

Flange

Fully modular to IEC and Compact integrated motor. NEMA C flange

Gears

Hardened and ground gears.

Removable inspection cover

Allows periodic inspection of gearing during routine maintenance

Output shaft

With well proportioned bearings

Feet

Removable feet.

Single-piece aluminum alloy housing

Combines light weight with high tensile strength. Precision machined for alignment of bearings and gearing

Ideal for use as first step with wormgearboxes.

Lubricated for life with synthetic oil with operative range from -15° to +130°C

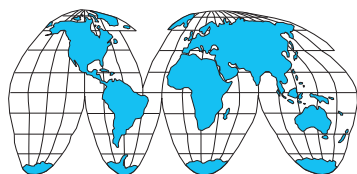

World wide sales network.

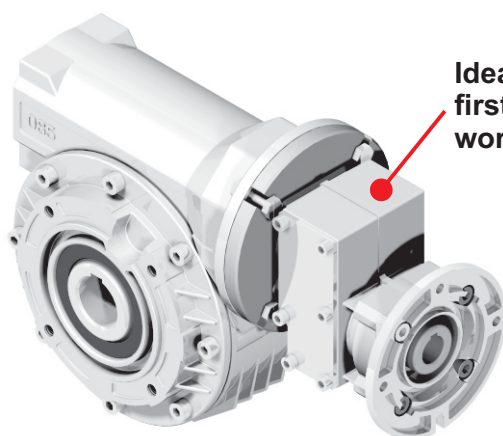
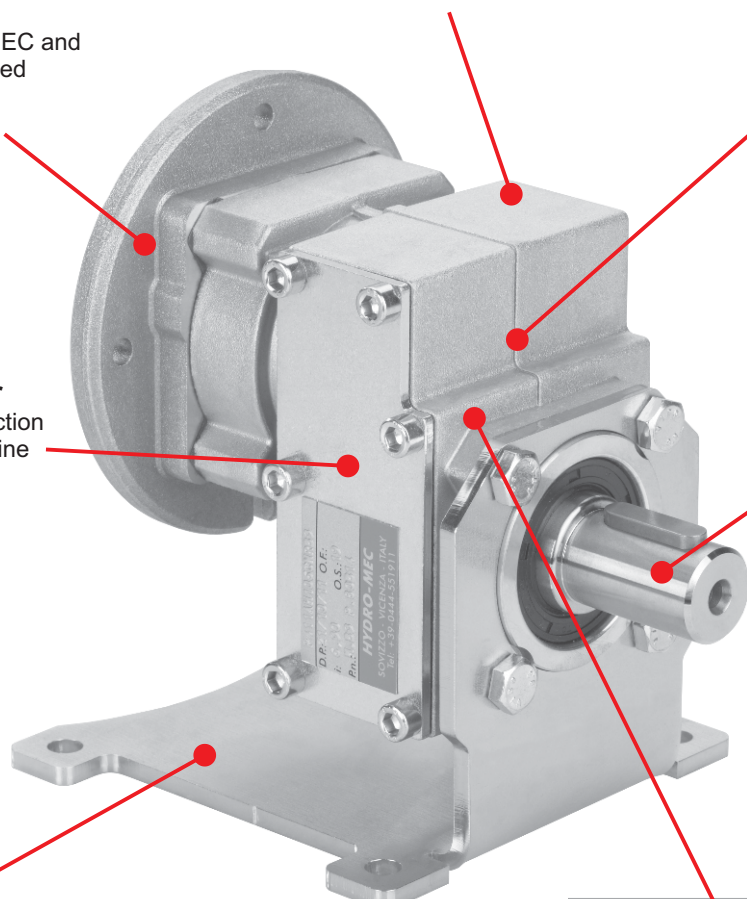

Specific type datasheet on page...

On page / A pagina / Auf Seite / À la page / En la página

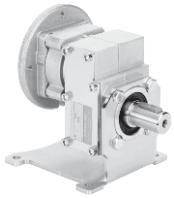

Types / Tipi
Tipen / Types
Tipos



4-5	4-7	4-9	4-11
211A 20Nm	311A 30Nm	411A 38Nm	511A 110Nm

On page / A pagina / Auf Seite / À la page / En la página

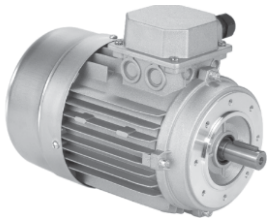

Types / Tipi
Tipen / Types
Tipos

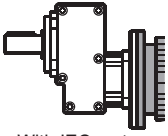
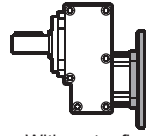
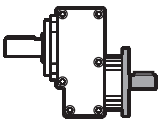
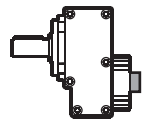
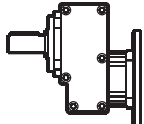
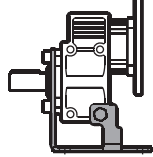
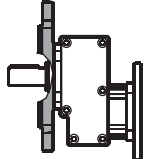

M-1									
56A 56B	63A 63B	71A 71B	80A 80B	90S 90L	100LA 100LB	112M	132S 132M	160M 160L	180M 180L

Type - Tipo - Typ Type - Tipo	Size - Grandezza - Grösse Taille - Tomaño	Mounting - Montaggio Montage - Fixation Tipo de montaje
P	311A	-F
<p>Aluminum one step gear Riduttori in alluminio a uno stadio</p> <div style="display: flex; justify-content: space-around;"> <div style="text-align: center;">  With IEC motor M </div> <div style="text-align: center;">  With motor flange P </div> </div> <div style="display: flex; justify-content: space-around; margin-top: 20px;"> <div style="text-align: center;">  With male input shaft R </div> <div style="text-align: center;">  Modular Base B </div> </div>	<p>1 Stages Riduzioni Stufen Trains Etapas</p> <div style="background-color: #cccccc; padding: 10px; margin: 10px auto; width: 80px; text-align: center;"> 211A 311A 411A 511A </div>	<div style="display: flex; justify-content: space-around; margin-top: 20px;"> <div style="text-align: center;">  Without flange / feet -N </div> <div style="text-align: center;">  Mounted feet H1 </div> </div> <div style="text-align: center; margin-top: 20px;">  Output flange mounted -F </div>

4

Special output shaft
Albero uscita speciale

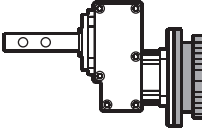

Only on request for Q.ty
A richiesta per quantità

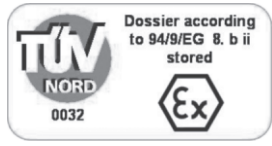

On request we can deliver our products according to the ATEX
 A richiesta possiamo fornire i nostri prodotti secondo le normative ATEX
 Auf Anfrage können wir unsere Produkte den Richtlinien ATEX entsprechend liefern
 Sur demande nos produits peuvent se conformer à la réglementation ATEX
 A pedido, se pueden enviar nuestros productos de acuerdo con las normas ATEX.

Ratio - Rapporto
Untersetzung
Reduction
Relación

Output shaft
Albero uscita
Abtriebswelle
Arbre de sortie
Eje en salida

Output flange
Flangia uscita
Ausgangsflansch
Bride de sortie
Brida en salida

Motor size - Grandezza motore
Motor Grösse
Grandeur moteur - Tamaño motor

Terminal box position
Posizione morsetteria
Klemmkastenlage
Position boîte à bornes
Posición caja de bornes

Mounting position
Posizione montaggio
Einbaulage
Position de montage
Posición de montaje

2.84

S

2

-C

B

B3

See technical data table

Vedi tabella dati tecnici.

Technisches Datenblatt beachten

Voir Tableau données techniques

Ver tabla datos técnicos

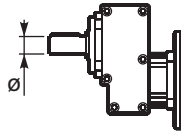

→ STANDARD

211A

S → **∅14**

311A

S → **∅14**

C → **∅19**

E → **∅24**

411A

S → **∅14**

C → **∅19**

E → **∅24**

511A

C → **∅19**

E → **∅24**

G → **∅28**

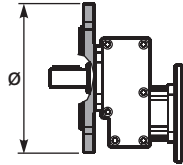

N Senza flangia
Without flange

211A

I → **∅105**

Flangia integrata
Integrated flange

311A

1 → **∅120**

2 → **∅140**

3 → **∅160**

4 → **∅200**

411A

1 → **∅120**

2 → **∅140**

3 → **∅160**

4 → **∅200**

511A

1 → **∅120**

2 → **∅140**

3 → **∅160**

4 → **∅200**

5 → **∅250**

Standard Flange
Flangia Standard

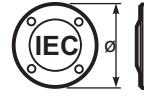

B5

B14

-A=56
(∅120)

-O=56
(∅80)

-B=63
(∅140)

-P=63
(∅90)

-C=71
(∅160)

-Q=71
(∅105)

-D=80
(∅200)

-R=80
(∅120)

-E=90
(∅200)

-T=90
(∅140)

-F=100+112
(∅250)

-U=100+112
(∅160)

-G=132
(∅300)

-V=132
(∅200)

Type R / Tipo R



211A

311A

511A

-1 → **∅14**

-3 → **∅24**

411A

-2 → **∅19**

Without flange / Senza flangia



211A

311A

411A

-Z → **∅9**
(56B5)

-1 → **∅14**
(71B5)

-0 → **∅11**
(63B5)

-2 → **∅19**
(80B5)

-1 → **∅14**
(71B5)

-3 → **∅24**
(90B5)

511A

-2 → **∅19**
(80B5)

-3 → **∅24**
(90B5)

-4 → **∅28**
(100B5)

→ STANDARD



A



B

STANDARD



C



D

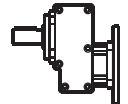

B3

STANDARD

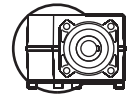

B6

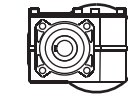

B7

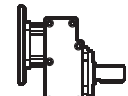

B8

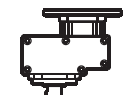

V5

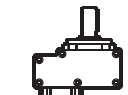

V6

Specify only for vertical positions

Specificare solo per posizione verticale

POTENZA RICHIESTA / REQUIRED POWER / ERFORDERLICHE LEISTUNG / PUISSANCE NECESSAIRE / POTENCIA NECESARIA

Lifting / sollevamento / hubantriebe / levage / elevación

$$P [KW] = \frac{M [Kg] \cdot g [9.81] \cdot v [m / s]}{1000}$$

Rotation / rotazione / drehung / rotation / rotação

$$P [KW] = \frac{M [Nm] \cdot n [rpm]}{9550}$$

Linear movement / traslazione / linearbewegung / translation / translación

$$P [KW] = \frac{F [N] \cdot v [m / s]}{1000}$$

TORQUE / COPPIA / DREHMOMENT / COUPLE / PAR

$$M [Nm] = \frac{9550 \cdot P[KW]}{n [rpm]}$$

$$M [lb in] = \frac{63030 \cdot P[HP]}{n [rpm]}$$

RADIAL LOADS / CARICHI RADIALI / RADIALE - UND AXIALLASTEN / CHARGES RADIALES / CARGA RADIAL Y AXIAL

- Radial load generated by external transmissions keyed onto input and/or output shafts.
- Forza radiale generata da organi di trasmissione calettati sugli alberi di ingresso e/o uscita.
- Belastungen der Antriebs- bzw. Abtriebswellen durch von aussen eingebrachte Radiallasten.
- Charge radiale générée par la transmissions calés sur les entrées et / ou des arbres de sortie
- Cargas radiales, generada por transmisiones externas, aplicadas sobre los ejes de entrada y/o salida

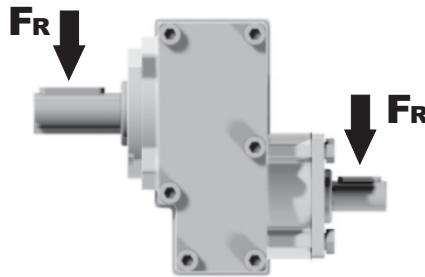

	$F_R [N] = \frac{M [Nm] \cdot 2000}{d [mm]} \cdot f_k$	$F_R [N] = \frac{M [lb in] \cdot 8.9}{d [in]} \cdot f_k$
M	Momento torcente / Output torque / Abtriebsdrehmoment / Couple / Par torsion	
d	Diametro primitivo / Diam. of driving element / Durchmesser der Abtriebseinheit / Diamètre primitif / Diámetro primitivo	
f_k	Coefficiente di trasformazione / Factor / Faktor / Coefficient de transmission / Coeficiente de transmisión 1.15 Ingranaggi / Gearwheels / Zahnrad / Engrenage / Engranaje 1.25 Catena / Chain sprockets / Antriebskette / Chaîne / Cadena 1.75 Cinghia Trapezoidale / Narrow v-belt pulley / Keilriemen / Courroie trap. / Correa trapezoidal 2.50 Cinghia piatta / Flat-belt pulley / Flachzahnriem. / Courroie crantée / Correa plana	

- If your application requires higher radial loads, contact our technical office. Higher load may be possible.
- Nel caso la vostra applicazione richieda carichi radiali superiori consultare il nostro ufficio tecnico, valori maggiori possono essere accettati.
- Wenn Ihre Anwendung höhere Radialbelastungen erfordert, so wenden Sie sich bitte an unser technischen Büro.
- Si votre application demande des charges radiales supérieures, s'adresser à notre bureau technique.
- En el caso en que una aplicación exija una carga radial superior a la especificada en el catálogo, consultar a nuestra oficinas técnica.

How to select a gearbox / Come selezionare un riduttore / Wie wählt man ein Getriebe
Comment sélectionner un réducteur / Cómo seleccionar un reductor

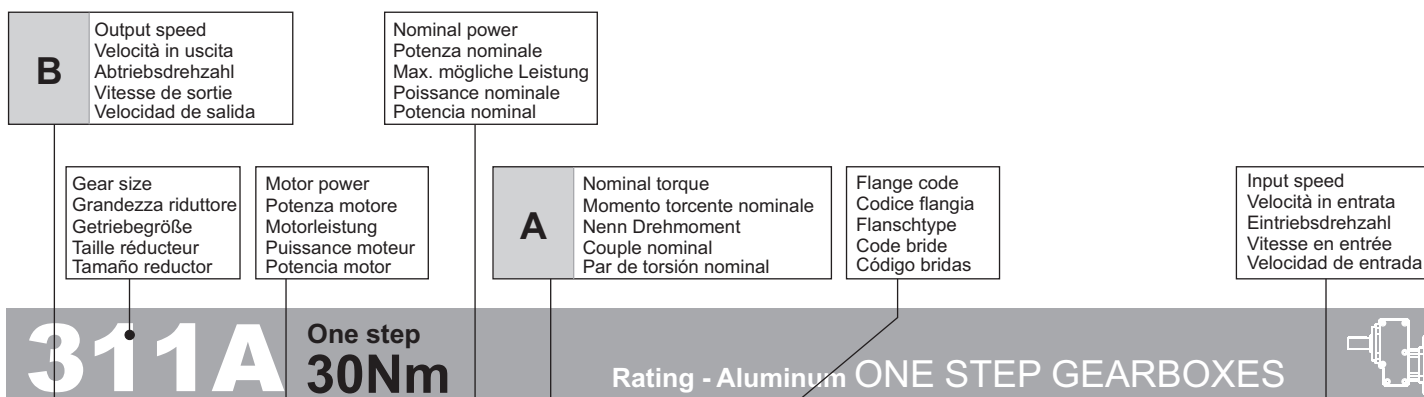

QUICK SELECTION / Selezione veloce input speed (n₁) = 1400 min⁻¹

Output Speed n ₂ [min ⁻¹]	Ratio i	Motor power P _{1M} [kW]	Output torque M _{2M} [Nm]	Service factor f.s.	Nominal power P _{1R} [kW]	Nominal torque M _{2R} [Nm]	Available B5 motor flanges		Available B14 motor flanges			Output Shaft Ø	Ratios code
							B	C	O	P	Q		
892	1.57	0.37	3.9	3.3	1.24	13			C	C		2844	01
493	2.84	0.37	7.0	3.3	1.21	23			C	C		1954	02
426	3.29	0.37	8.1	3.2	1.18	26			C	C		1756	03
362	3.87	0.37	9.6	2.9	1.08	28			C	C		1558	04

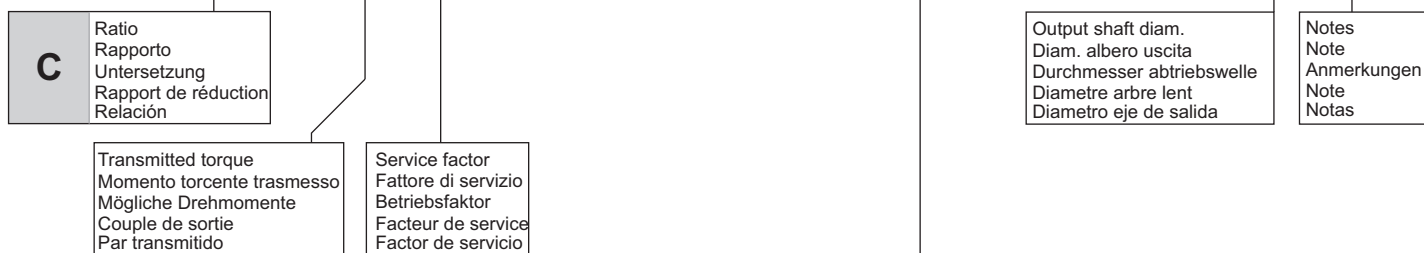

fs

Type of load and starts per hour Tipo di carico e avviamenti per ora		Oper. hours per day Ore di funz. giorn.		
		3 h	10 h	24 h
Continuous or intermittent appl. with start / hour Applicazione cont. o interm. con n.ro operazioni/ora	Uniform / Uniforme	0.8	1	1.25
	Moderate / Moderato	1	1.25	1.5
	Heavy / Forte	1.25	1.5	1.75
Intermittent application with start / hour Applicazione intermittente con n.ro operazioni/ora	Uniform / Uniforme	1	1.25	1.5
	Moderate / Moderato	1.25	1.5	1.75
	Heavy / Forte	1.5	1.75	2.15

D Motor flange available
Flange disponibili
Erhältliche Motorflansche
Brides disponibles
Bridas disponibles

B) Mounting with reduction ring
Montaggio con boccola di riduzione
Reduzierhülsen
Montage avec douille de réduction
Montaje con casquillo de reducción

C) Motor flangeholes position/terminal box position
Posizione fori flangia/basetta motore
Bohrungsposition am Motorflansch/-sockel
Position trous bride/barrette à bornes moteur
Posición agujeros brida / base motor



B) Available without reduction bushes
Disponibile anche senza boccola
Auch ohne Reduzierbuchse verfügbar
Disponible aussi sans douille de réduction
Disponible también sin casquillo

A	Select required torque (according to service factor)	Seleziona la coppia desiderata (comprensiva del fattore di servizio)	Max. Drehmoment in Bezug zum Betriebsfaktor	Sélectionner le couple souhaité (comprenant le facteur de service)	Seleccionar el par deseado (incluyendo el factor de servicio)
B	Select output speed	Seleziona la velocità in uscita	Ausgewählte Abtriebsdrehzahl	Sélectionner la vitesse de sortie	Seleccionar la velocidad de salida
C	On the same line of selected geared motor, you can find the gear ratio	Sulla riga corrispondente alla motorizzazione prescelta si può rilevare il rapporto di riduzione	Auf der gleichen Linie wie die ausgewählte Motorleistung steht auch die Getriebeuntersetzung	Sur la ligne correspondante à la motorisation pré-choisie on peut relever le rapport de réduction	En la línea correspondiente al motor preseleccionado es posible encontrar la relación de reducción
D	Select motor flange available (if requested)	Scegli la flangia disponibile (se richiesta)	Erhältliche Motorflansche (auf Anfrage)	Choisir la bride disponible (si elle est demandée)	Seleccionar la brida disponible (sobre pedido)



QUICK SELECTION / Selezione veloce

input speed (n_1) = 1400 min⁻¹

Output Speed n_2 [min ⁻¹]	Ratio i	Motor power P_{1M} [kW]	Output torque M_{2M} [Nm]	Service factor f.s.	Nominal power P_{1R} [kW]	Nominal torque M_{2R} [Nm]	Available B5 motor flanges				Available B14 motor flanges				Output Shaft  standard ø14	Ratios code 
							B	C	D	E	O	P	Q	R		
							63	71	80	90	56	63	71	80		
682	2.05	0.37	5	2.0	0.73	10					C	C			1939	01
595	2.35	0.37	6	2.1	0.76	12					C	C			1740	02
500	2.80	0.37	7	2.0	0.75	14					C	C			1542	03
414	3.38	0.37	8	2.0	0.75	17					C	C			1344	04
298	4.70	0.37	12	1.7	0.64	20					C	C			1047	05
225	6.22	0.37	15	1.5	0.55	23					C	C			956	06
169	8.29	0.37	20	1.0	0.36	20					C	C			758	07
142	9.83	0.25	16	1.0	0.24	16					C	C			659	08

The dynamic efficiency is **0.98** for all ratios

 Motor Flanges Available
Flange Motore Disponibili

 B) Supplied with Reduction Bushing
Fornito con Bussola di Riduzione

 B) Available on Request without reduction bushing
Disponibile a Richiesta senza Bussola di Riduzione

 C) Motor Flange Holes Position
Posizione Fori Flangia Motore

4

EN Unit **211A** is supplied with synthetic oil for lifetime lubrication, no maintenance is necessary. See table 1 for lubrication and recommended quantity. In table 2 please see possible radial loads and axial loads on the gearbox.

I Il riduttore **211A** viene fornito completo di olio sintetico per la lubrificazione permanente e non necessita di alcuna manutenzione. Vedi tab.1 per oli e quantità consigliati. In tab.2 sono presenti i carichi radiali e assiali applicabili al riduttore.

D Das Getriebe **211A** ist mit synthetischem Öl gefüllt und ist lebensdauer geschmiert. In Tabelle 1 ist die Schmiermenge und das empfohlene Schmiermittel angegeben. In Tabelle 2 sind die zulässigen Radial- und Axialbelastungen des Getriebes aufgeführt.

F Le réducteur **211A** est fourni complet avec de l'huile synthétique pour la lubrification permanente et ne nécessite aucun entretien. Voir tableau 1 concernant les huiles et les quantités conseillées. Les charges radiales et axiales applicables au réducteur sont précisées dans le tableau 2.

E El reductor tamaño **211A** se suministra, lubricado de por vida con aceite sintético y no requieren mantenimiento alguna. Ver tabla 1, para cantidades y aceites recomendados. En la tabla 2, se encuentran las cargas radiales y axiales admitidas por el reductor.

LUBRICATION 211A Oil Quantity 0.05 Lt.

AGIP Telium VSF 320

SHELL Omala S4 WE 320

For all details on lubrication and plugs check our website **tab. 1**
Per maggiori dettagli su lubrificazione e tappi olio vedi il nostro sito web

RADIAL AND AXIAL LOADS

Output shaft

Albero di uscita

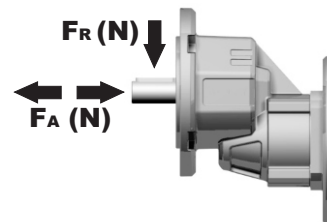

n_2	FA	FR
700	101	504
600	120	600
400	138	696
300	151	756
200	175	876
140	192	960

Input shaft

albero in entrata

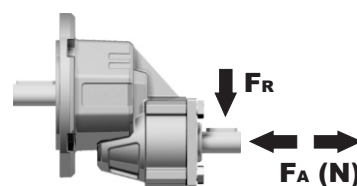

n_2	FA	FR
1400	168	840
900	192	960

*Strong axial loads in the DX direction are not allowed.
Non sono consentiti forti carichi assiali con direzione DX

tab. 2

P211A-F... Basic wormbox
Riduttore base

Gearbox weight
peso riduttore **1.40 kg**

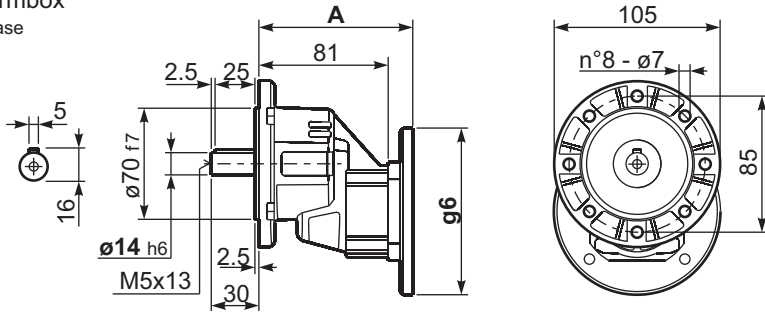

B5 Motor Flanges	A	g6	kit code
63 B5	99.5	138	K050.4.041
71 B5	97	160	K050.4.042

B14 Motor Flanges	A	g6	kit code
56 B14	97	80	KC40.4.049
63 B14	99.5	90	K050.4.047
71 B14	97	105	K050.4.045

R211A-F... Basic wormbox
Riduttore base

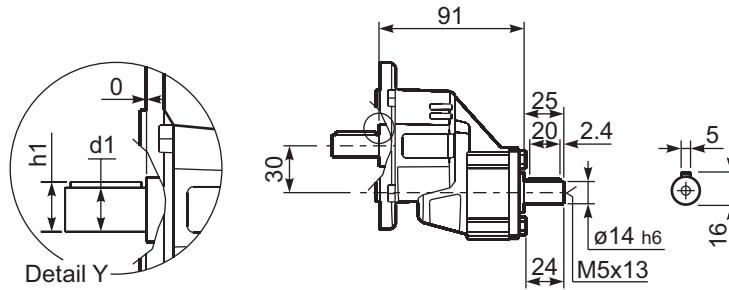

*Available output shaft / Albero di uscita

	Shaft - d1	p1	h1	x
Standard	$\phi 14 \times 30$	5	16	M5x13



QUICK SELECTION / Selezione veloce

input speed (n_1) = 1400 min⁻¹

Output Speed n_2 [min ⁻¹]	Ratio i	Motor power P_{1M} [kW]	Output torque M_{2M} [Nm]	Service factor f.s.	Nominal power P_{1R} [kW]	Nominal torque M_{2R} [Nm]	Available B5 motor flanges		Available B14 motor flanges			Output Shaft 	Ratios code	
							B	C	O	P	Q			
891	1.57	0.37	4	3.3	1.2	13			C	C		2844	standard ø14	01
493	2.84	0.37	7	3.3	1.2	23			C	C		1954		02
425	3.29	0.37	8	3.2	1.2	26			C	C		1756		03
362	3.87	0.37	10	2.9	1.1	28			C	C		1558		04
303	4.62	0.37	11	2.6	0.97	30			C	C		1360		On request
222	6.30	0.37	16	2.2	0.83	35			C	C		1063		ø19
170	8.22	0.37	20	1.9	0.69	38			C	C		974		ø24
129	10.86	0.37	27	1.0	0.39	28			C	C		776		08

The dynamic efficiency is **0.98** for all ratios

A Motor Flanges Available
Flange Motore Disponibili

B Supplied with Reduction Bushing
Fornito con Bussola di Riduzione

B Available on Request without reduction bushing
Disponibile a Richiesta senza Bussola di Riduzione

C Motor Flange Holes Position
Posizione Fori Flangia Motore

4

EN Unit **311A** is supplied with synthetic oil for lifetime lubrication, no maintenance is necessary. See table 1 for lubrication and recommended quantity. In table 2 please see possible radial loads and axial loads on the gearbox.

I Il riduttore **311A** viene fornito completo di olio sintetico per la lubrificazione permanente e non necessita di alcuna manutenzione. Vedi tab.1 per oli e quantità consigliati. In tab.2 sono presenti i carichi radiali e assiali applicabili al riduttore.

D Das Getriebe **311A** ist mit synthetischem Öl gefüllt und ist lebensdauergeschmiert. In Tabelle 1 ist die Schmiermenge und das empfohlene Schmiermittel angegeben. In Tabelle 2 sind die zulässigen Radial- und Axialbelastungen des Getriebes aufgeführt.

F Le réducteur **311A** est fourni complet avec de l'huile synthétique pour la lubrification permanente et ne nécessite aucun entretien. Voir tableau 1 concernant les huiles et les quantités conseillées. Les charges radiales et axiales applicables au réducteur sont précisées dans le tableau 2.

E El reductor tamaño **311A** se suministra, lubricado de por vida con aceite sintético y no requieren mantenimiento alguna. Ver tabla 1, para cantidades y aceites recomendados. En la tabla 2, se encuentran las cargas radiales y axiales admitidas por el reductor.

LUBRICATION 311A Oil Quantity 0.10 Lt.

AGIP Telium VSF 320

SHELL Omala S4 WE 320

For all details on lubrication and plugs check our website

tab. 1

Per maggiori dettagli su lubrificazione e tappi olio vedi il nostro sito web

RADIAL AND AXIAL LOADS

Output shaft

Albero di uscita

$$F_{eq} = F_R \cdot \frac{38.5}{X+18.5}$$

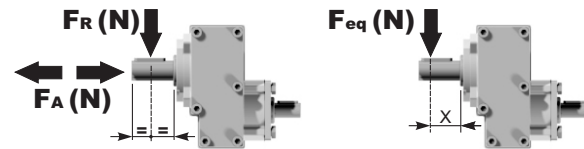

n_2	FA	FR	n_2	FA	FR	n_2	FA	FR
700	120	640	400	160	800	200	200	1020
600	140	700	300	175	880	140	225	1120

Input shaft

Albero in entrata

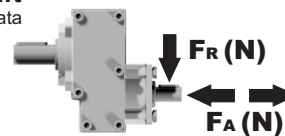

n_1	FA	FR
1400	180	860
900	200	980

tab. 2

P311-F... Output flange
flange di uscita

Gearbox weight **2.50 kg**
peso riduttore

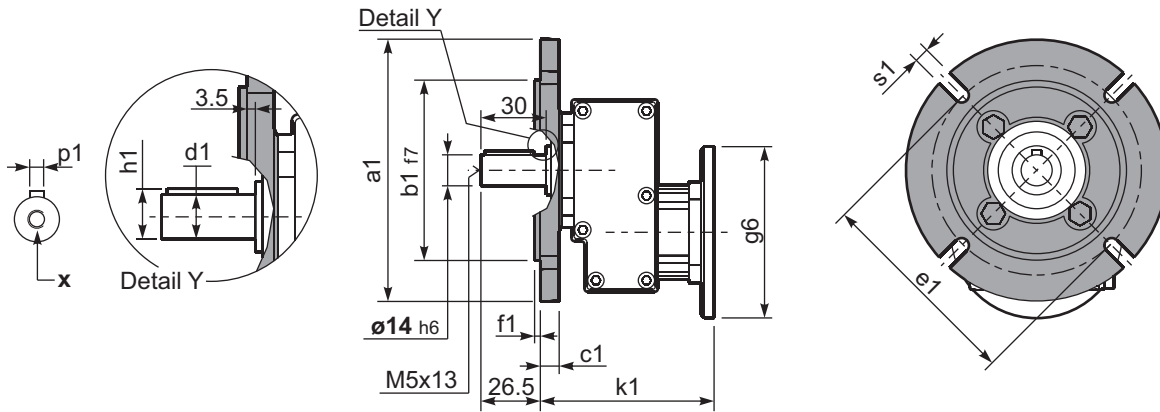

***Available output shaft / Albero di uscita**

	Shaft - d1	p1	h1	x
Standard	ø 14x30	5	16	M5x13
On request A richiesta	ø 19x40 ø 24x40	6 8	21.5 27	M6x16 M6x16

Available output flanges / flange di uscita

a1 ø	b1	c1	e1	f1	s1	kit code
120	80	11.5	100	3	9*	KC30.9.010
140	95	11.5	115	3	9	KC30.9.011
160	110	11.5	130	3.5	9	KC30.9.012
200	130	11.5	165	3.5	11	KC30.9.013

*Holes position
posizione fori

P311-H1... With feet
Con piedini

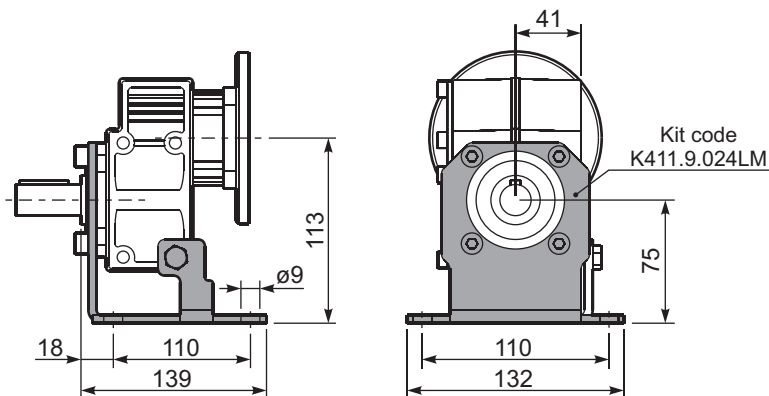

R311-N... Input Shaft
Albero in entrata

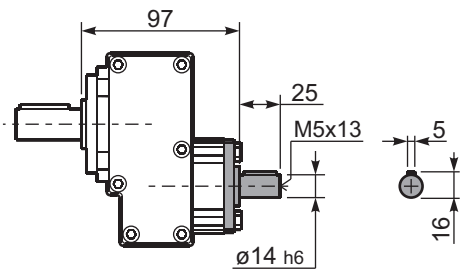

P311-N... Basic gearbox
Riduttore base

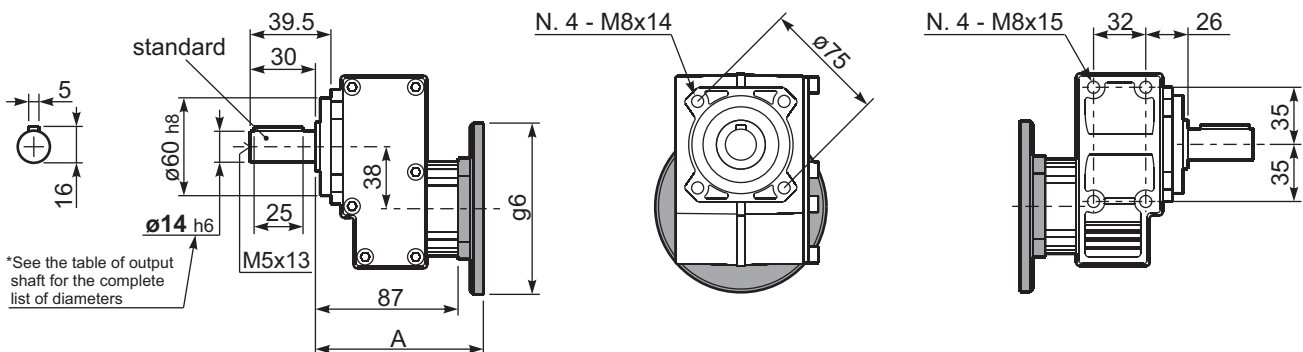

B14 Motor Flanges	A	g6	k1	kit code
56 B14	103	80	106.5	KC40.4.049
63 B14	105.5	90	109	K050.4.047
71 B14	103	105	106.5	K050.4.045

B5 Motor Flanges	A	g6	k1	kit code
63 B5	105.5	138	109	K050.4.041
71 B5	103	160	106.5	K050.4.042



QUICK SELECTION / Selezione veloce

input speed (n_1) = 1400 min⁻¹

Output Speed n_2 [min ⁻¹]	Ratio i	Motor power P_{1M} [kW]	Output torque M_{2M} [Nm]	Service factor f.s.	Nominal power P_{1R} [kW]	Nominal torque M_{2R} [Nm]	Available B5 motor flanges				Available B14 motor flanges			Output Shaft 	Ratios code	
							B	C	D	E	Q	R	T			
							63	71	80	90	71	80	90			
891	1.57	1.5	16	1.3	1.9	20	B				C	C		2844	standard ø19 On request ø14 ø24	01
493	2.84	1.5	28	1.2	1.8	35	B				C	C		1954		02
425	3.29	1.5	33	1.2	1.7	38	B				C	C		1756		03
362	3.87	1.5	39	1.0	1.5	40	B				C	C		1558		04
303	4.62	1.5	46	1.0	1.5	47	B				C	C		1360		05
222	6.30	1.1	46	1.0	1.1	46	B				C	C		1063		06
170	8.22	0.55	30	1.3	0.69	38	B				C	C		974		07
129	10.86	0.37	27	1.0	0.39	28	B				C	C		776		08

The dynamic efficiency is **0.98** for all ratios

Motor Flanges Available
Flange Motore Disponibili

B) Supplied with Reduction Bushing
Fornito con Bussola di Riduzione

B) Available on Request without reduction bushing
Disponibile a Richiesta senza Bussola di Riduzione

C) Motor Flange Holes Position
Posizione Fori Flangia Motore

4

EN Unit **411A** is supplied with synthetic oil for lifetime lubrication, no maintenance is necessary. See table 1 for lubrication and recommended quantity. In table 2 please see possible radial loads and axial loads on the gearbox.

I Il riduttore **411A** viene fornito completo di olio sintetico per la lubrificazione permanente e non necessita di alcuna manutenzione. Vedi tab.1 per oli e quantità consigliati. In tab.2 sono presenti i carichi radiali e assiali applicabili al riduttore.

D Das Getriebe **411A** ist mit synthetischem Öl gefüllt und ist lebensdauergeschmiert. In Tabelle 1 ist die Schmiermenge und das empfohlene Schmiermittel angegeben. In Tabelle 2 sind die zulässigen Radial - und Axialbelastungen des Getriebes aufgeführt.

F Le réducteur **411A** est fourni complet avec de l'huile synthétique pour la lubrification permanente et ne nécessite aucun entretien. Voir tableau 1 concernant les huiles et les quantités conseillées. Les charges radiales et axiales applicables au réducteur sont précisées dans le tableau 2.

E El reductor tamaño **411A** se suministra, lubricado de por vida con aceite sintético y no requieren mantenimiento alguna. Ver tabla 1, para cantidades y aceites recomendados. En la tabla 2, se encuentran las cargas radiales y axiales admitidas por el reductor.

LUBRICATION 411A Oil Quantity 0.20 Lt.

AGIP Telium VSF 320

SHELL Omala S4 WE 320

For all details on lubrication and plugs check our website

tab. 1

Per maggiori dettagli su lubrificazione e tappi olio vedi il nostro sito web

RADIAL AND AXIAL LOADS

Output shaft

Albero di uscita

$$F_{eq} = F_R \cdot \frac{40}{X+20}$$

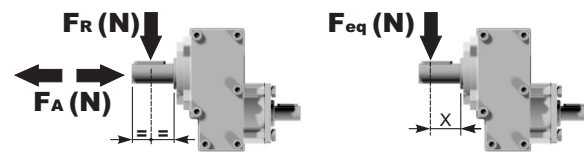

n_2	FA	FR	n_2	FA	FR	n_2	FA	FR
700	182	910	400	230	1150	200	290	1450
600	200	1000	300	250	1250	140	320	1600

Input shaft

Albero in entrata

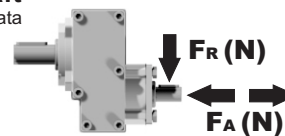

n_1	FA	FR
1400	240	1200
900	280	1400

tab. 2

P411-F... Output flange
flange di uscita

Gearbox weight
peso riduttore **3.20 kg**

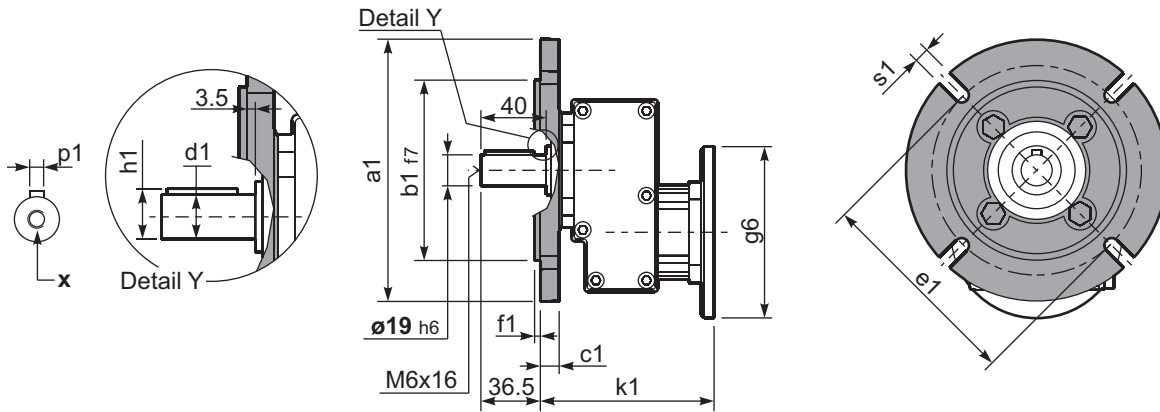

***Available output shaft / Albero di uscita**

	Shaft - d1	p1	h1	x
Standard	∅ 19x40	6	21.5	M6x16
On request A richiesta	∅ 14x30 ∅ 24x40	5 8	16 27	M5x13 M6x16

Available output flanges / flange di uscita

a1 ∅	b1	c1	e1	f1	s1	kit code
120	80	11.5	100	3	9*	KC30.9.010
140	95	11.5	115	3	9	KC30.9.011
160	110	11.5	130	3.5	9	KC30.9.012
200	130	11.5	165	3.5	11	KC30.9.013

*Holes position
posizione fori



P411-H1... With feet
Con piedini

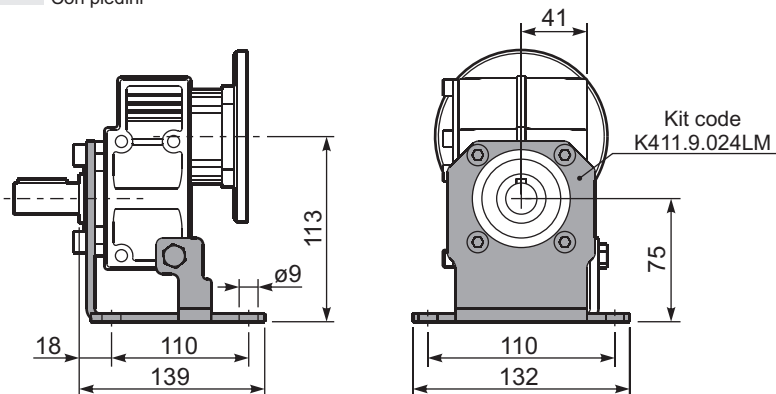

R411-N... Input Shaft
Albero in entrata

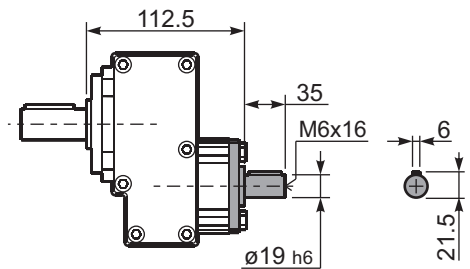

P411-N... Basic gearbox
Riduttore base

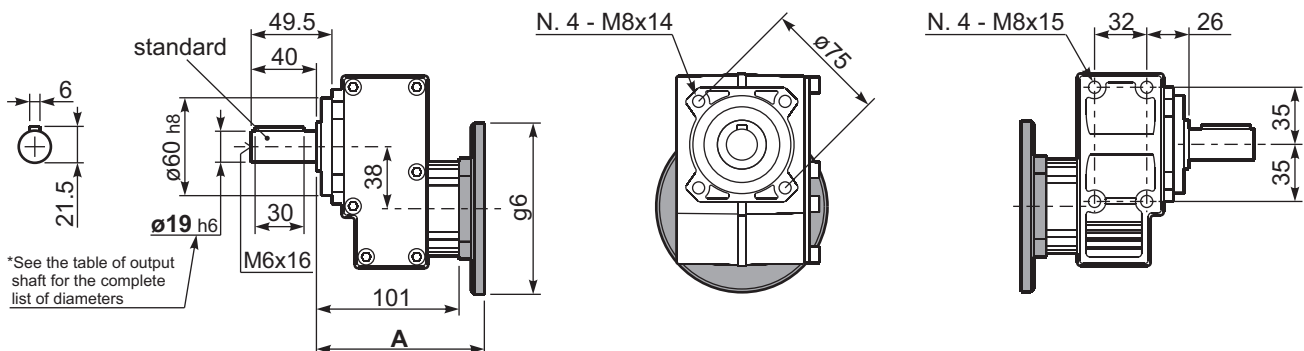

B5 Motor Flanges	A	g6	k1	kit code
63 B5	121.5	140	125	K063.4.041
71 B5	119.5	160	123	K063.4.042
80/90 B5	121.5	200	125	K063.4.043

B14 Motor Flanges	A	g6	k1	kit code
71 B14	119.5	105	123	K063.4.047
80 B14	121.5	120	125	K063.4.046
90 B14	121.5	140	125	K063.4.041



QUICK SELECTION / Selezione veloce

input speed (n_1) = 1400 min⁻¹

Output Speed n_2 [min ⁻¹]	Ratio i	Motor power P_{1M} [kW]	Output torque M_{2M} [Nm]	Service factor f.s.	Nominal power P_{1R} [kW]	Nominal torque M_{2R} [Nm]	Available B5 motor flanges					Available B14 motor flanges				Output Shaft 	Ratios code			
							C	D	E	F	G	R	T	U	V					
							71	80	90	100 112	132	80	90	100 112	132					
1077	1.30	4	34	1.2	4.6	40	B										3039	standard ø28	01	
571	2.45	4	64	1.1	4.3	70	B										2049		02	
423	3.31	4	87	1.0	4.1	90	B										1653		03	
325	4.31	4	113	1.0	3.8	110	B										1356		04	
266	5.27	3	104	1.1	3.1	110	B										1158		On request	05
184	7.63	2.2	111	1.0	2.2	110	B										861		ø19	06
133	10.50	1.1	77	1.0	1.1	80	B										663		ø24	07

The dynamic efficiency is **0.98** for all ratios

A Motor Flanges Available
Flange Motore Disponibili

B Supplied with Reduction Bushing
Fornito con Bussola di Riduzione

B Available on Request without reduction bushing
Disponibile a Richiesta senza Bussola di Riduzione

C Motor Flange Holes Position
Posizione Fori Flangia Motore

EN Unit **511A** is supplied with synthetic oil for lifetime lubrication, no maintenance is necessary. See table 1 for lubrication and recommended quantity. In table 2 please see possible radial loads and axial loads on the gearbox.

I Il riduttore **511A** viene fornito completo di olio sintetico per la lubrificazione permanente e non necessita di alcuna manutenzione. Vedi tab.1 per oli e quantità consigliati. In tab.2 sono presenti i carichi radiali e assiali applicabili al riduttore.

D Das Getriebe **511A** ist mit synthetischem Öl gefüllt und ist lebensdauergeschmiert. In Tabelle 1 ist die Schmiermenge und das empfohlene Schmiermittel angegeben. In Tabelle 2 sind die zulässigen Radial- und Axialbelastungen des Getriebes aufgeführt.

F Le réducteur **511A** est fourni complet avec de l'huile synthétique pour la lubrification permanente et ne nécessite aucun entretien. Voir tableau 1 concernant les huiles et les quantités conseillées. Les charges radiales et axiales applicables au réducteur sont précisées dans le tableau 2.

E El reductor tamaño **511A** se suministra, lubricado de por vida con aceite sintético y no requieren mantenimiento alguna. Ver tabla 1, para cantidades y aceites recomendados. En la tabla 2, se encuentran las cargas radiales y axiales admitidas por el reductor.

LUBRICATION 511A Oil Quantity 0.29 Lt.

AGIP Telium VSF 320

SHELL Omala S4 WE 320

For all details on lubrication and plugs check our website

tab. 1

Per maggiori dettagli su lubrificazione e tappi olio vedi il nostro sito web

RADIAL AND AXIAL LOADS

Output shaft

Albero di uscita

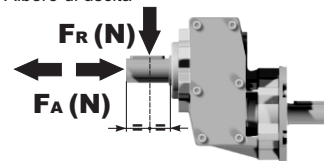

$$F_{eq} = FR \cdot \frac{52.5}{X+22.5}$$

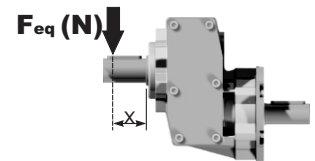

n_2	FA	FR	n_2	FA	FR	n_2	FA	FR
700	294	1470	400	370	1850	200	460	2300
600	320	1600	300	400	2000	140	510	2550

Input shaft

Albero in entrata

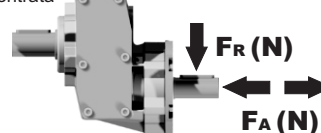

n_1	FA	FR
1400	400	2000
900	440	2200

tab. 2

P511-F... Output flanges
flange di uscita

Gearbox weight
peso riduttore **5.00 kg**

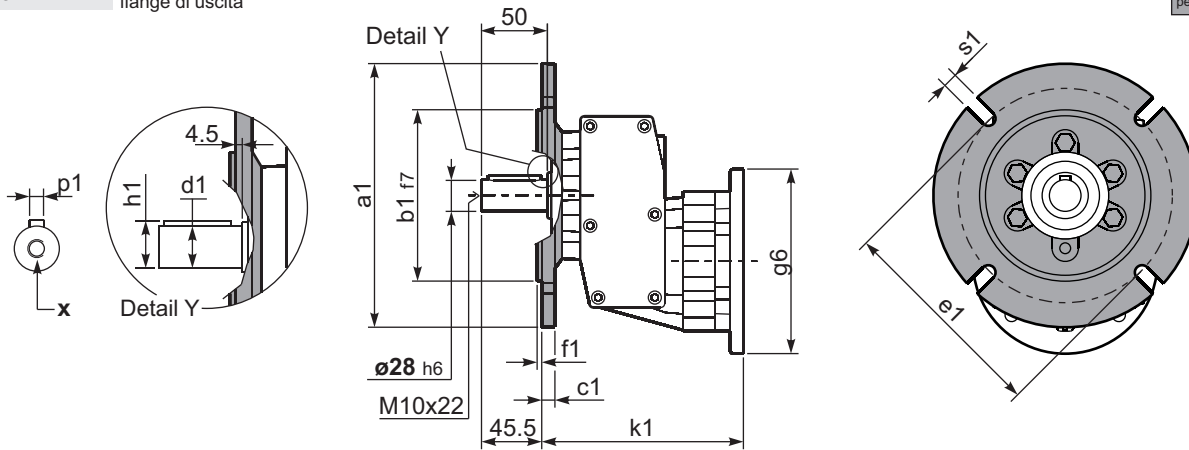

***Available output shaft / Albero di uscita**

	Shaft - d1	p1	h1	x
Standard	ø 28x50	8	31	M10x22
On request A richiesta	ø 24x50	8	27	M8x19
	ø 19x40	6	21.5	M6x16

Available output flanges / flange di uscita

a1 ø	b1	c1	e1	f1	s1	kit code
120	80	10	100	3	9	KC40.9.010
140	95	10	115	3	9	KC40.9.011
160	110	10	130	3	9	KC40.9.012
200	130	11	165	3.5	11	KC40.9.013
250	180	11.5	215	3.5	14	KC40.9.014

P511A-H1. With feet
Con piedini

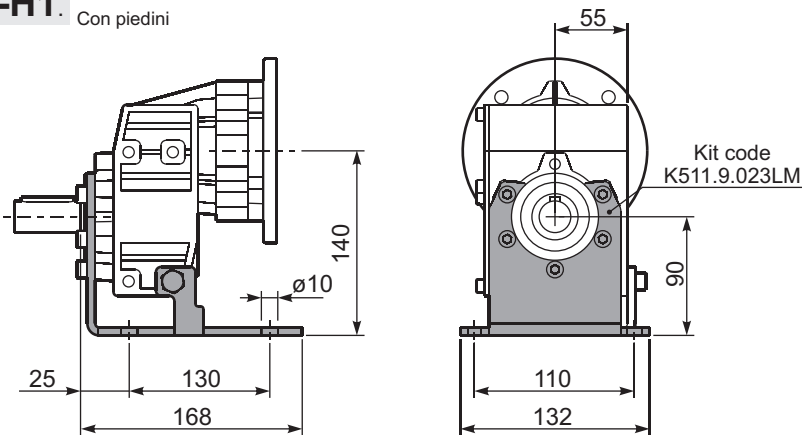

R511A-N... Input Shaft
Albero in entrata

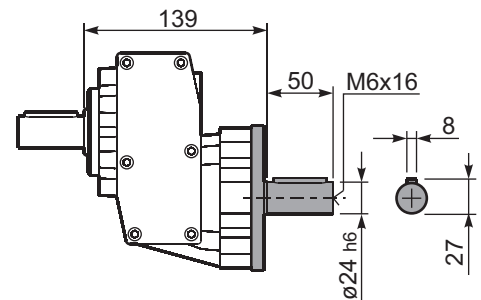

P511-N... Basic gearbox
Riduttore base

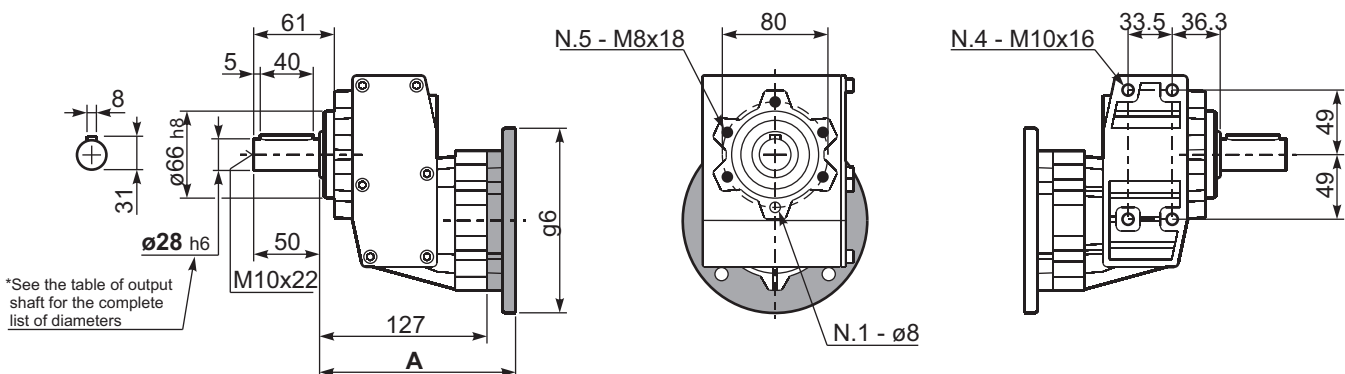

*See the table of output shaft for the complete list of diameters

B5 Motor Flanges	A	g6	k1	kit code
71 B5	145.5	160	150	KC023.4.041
80/90 B5	147.5	200	152	KC023.4.042
100/112 B5	156.5	250	161	KC023.4.043
132 B5	174.5	300	179	KC50.4.043

B14 Motor Flanges	A	g6	k1	kit code
80 B14	147.5	120	152	KC085.4.046
90 B14	147.5	140	152	KC085.4.045
100/112 B14	156.5	160	161	KC085.4.047
132 B14	174.5	200	179	KC50.4.041

Aluminum in line gearboxes

A modular and compact product

Alloy housing

Is vacuum impregnated (MIL-STD 276) for protection and sealing. No secondary finish required but readily accepts paint

Flange

Fully modular to IEC and Compact integrated motor. NEMA C flange

Removable inspection cover

Allows periodic inspection of gearing during routine maintenance

Oil seals

Two oil seals on request

Output shaft

With well proportioned bearings

Gears

Hardened and ground gears.

Feet

Removable feet. With patented locking system.

Foot prints

Compatible to the main standard of the market.

Lubricated for life with synthetic oil with operative range from -15° to $+130^{\circ}\text{C}$



Single-piece aluminum alloy housing

Combines light weight with high tensile strength. Precision machined for alignment of bearings and gearing

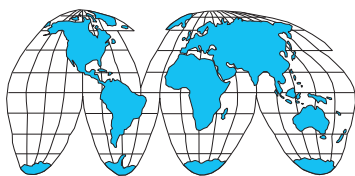
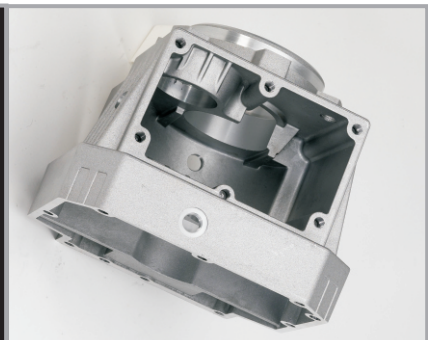
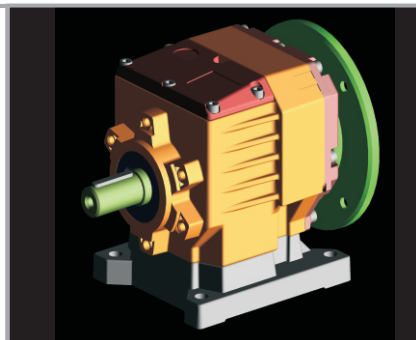

World wide sales network.

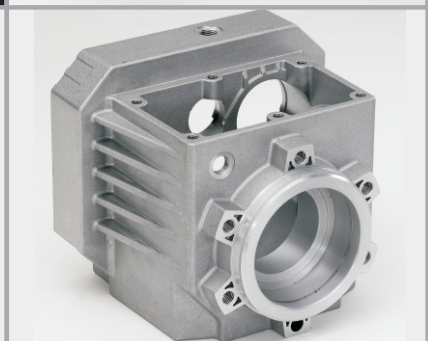
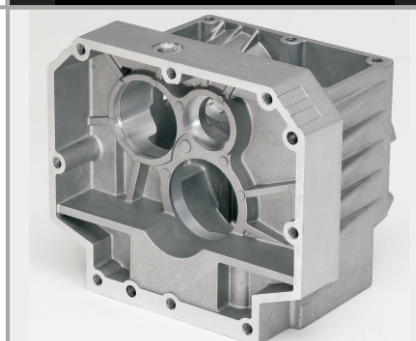

Specific type datasheet on page...

On page / A pagina / Auf Seite / À la page / En la página

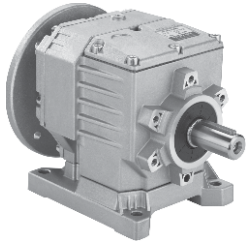

Types / Tipi
Tipen / Types
Tipos

5-5	5-7	5-9	5-11	5-13	5-15	5-17	5-19	5-21
202A 70Nm	302A 120Nm	402A 160Nm	403A 160Nm	452A 300Nm	502A 350Nm	503A 350Nm	602A 520Nm	603A 520Nm

On page / A pagina / Auf Seite / À la page / En la página

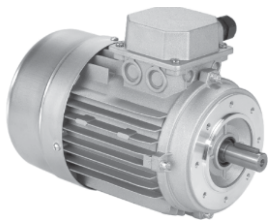

Types / Tipi
Tipen / Types
Tipos

M-1									
56A 56B	63A 63B	71A 71B	80A 80B	90S 90L	100LA 100LB	112M	132S 132M	160M 160L	180M 180L

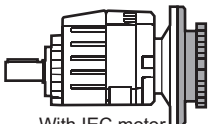
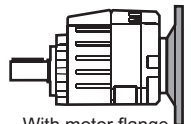
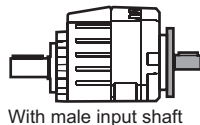
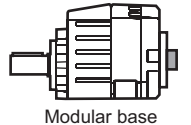
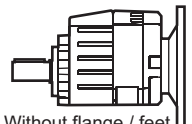
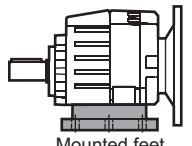
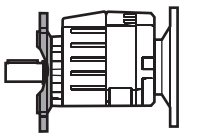
Type - Tipo - Typ Type - Tipo	Size - Grandezza - Grösse Taille - Tomafío	Mounting - Montaggio Montage - Fixation Tipo de montaje																																																								
P	402A	-F																																																								
<p>Aluminum coaxial gear boxes Riduttori coassiali in alluminio</p> <div style="display: flex; justify-content: space-around;"> <div style="text-align: center;">  <p>With IEC motor M</p> </div> <div style="text-align: center;">  <p>With motor flange P</p> </div> </div> <div style="display: flex; justify-content: space-around; margin-top: 20px;"> <div style="text-align: center;">  <p>With male input shaft R</p> </div> <div style="text-align: center;">  <p>Modular base B</p> </div> </div>	<div style="display: flex; justify-content: space-around;"> <div style="text-align: center;"> <p>2 Stages Riduzioni Stufen Trains Etapas</p> <div style="background-color: #cccccc; padding: 5px; text-align: center;"> <p>202A 302A 402A 452A 502A 602A</p> </div> </div> <div style="text-align: center;"> <p>3 Stages Riduzioni Stufen Trains Etapas</p> <div style="background-color: #cccccc; padding: 5px; text-align: center;"> <p>403A 503A 603A</p> </div> </div> </div>	<div style="display: flex; justify-content: space-around;"> <div style="text-align: center;">  <p>Without flange / feet -N</p> </div> <div style="text-align: center;">  <p>Mounted feet B..</p> </div> </div> <div style="margin-top: 20px;">  <p>Output flange mounted -F</p> </div> <div style="margin-top: 20px;"> <p>Feet / piedini</p> <table border="1"> <thead> <tr> <th>Feet Code reference</th> <th>G</th> <th>H</th> <th>R</th> <th>L</th> <th>L1</th> <th>S</th> </tr> </thead> <tbody> <tr> <td>B1</td> <td>112</td> <td>18</td> <td>85</td> <td>110</td> <td>87</td> <td>50</td> </tr> <tr> <td>B2</td> <td>212/3</td> <td>18</td> <td>100</td> <td>130</td> <td>107.5</td> <td></td> </tr> <tr> <td>S1</td> <td>17</td> <td>18</td> <td>75</td> <td>110</td> <td>90+20</td> <td></td> </tr> <tr> <td>S2</td> <td>27</td> <td>25</td> <td>90</td> <td>110</td> <td>130</td> <td></td> </tr> <tr> <td>M1</td> <td>42/3</td> <td>25</td> <td>80</td> <td>110+120</td> <td>85</td> <td></td> </tr> <tr> <td>L4</td> <td>04</td> <td>13</td> <td>80</td> <td>105</td> <td></td> <td></td> </tr> <tr> <td>L5</td> <td>05</td> <td>16</td> <td>100</td> <td>125</td> <td></td> <td></td> </tr> </tbody> </table> <p>You see feet code in the chart of the dimensions Vedi codice piede nella tabella delle dimensioni</p> </div>	Feet Code reference	G	H	R	L	L1	S	B1	112	18	85	110	87	50	B2	212/3	18	100	130	107.5		S1	17	18	75	110	90+20		S2	27	25	90	110	130		M1	42/3	25	80	110+120	85		L4	04	13	80	105			L5	05	16	100	125		
Feet Code reference	G	H	R	L	L1	S																																																				
B1	112	18	85	110	87	50																																																				
B2	212/3	18	100	130	107.5																																																					
S1	17	18	75	110	90+20																																																					
S2	27	25	90	110	130																																																					
M1	42/3	25	80	110+120	85																																																					
L4	04	13	80	105																																																						
L5	05	16	100	125																																																						

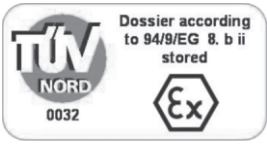

On request we can deliver our products according to the ATEX
 A richiesta possiamo fornire i nostri prodotti secondo le normative ATEX
 Auf Anfrage können wir unsere Produkte den Richtlinien ATEX entsprechend liefern
 Sur demande nos produits peuvent se conformer à la réglementation ATEX
 A pedido, se pueden enviar nuestros productos de acuerdo con las normas ATEX.

Ratio - Rapporto
Untersetzung
Reduction
Relación

Output shaft
Albero uscita
Abtriebswelle
Arbre de sortie
Eje en salida

Output flange
Flangia uscita
Ausgangsflansch
Bride de sortie
Brida en salida

Motor size - Grandezza motore
Motor Grösse
Grandeur moteur - Tamaño motor

Terminal box position
Posizione morsetteria
Klemmkastenlage
Position boîte à bornes
Posición caja de bornes

Mounting position
Posizione montaggio
Einbaulage
Position de montage
Posición de montaje

7.33

V

2

-C

B

B3

See technical data table

Vedi tabella dati tecnici

Technisches Datenblatt beachten

Voir Tableau données techniques

Ver tabla datos técnicos

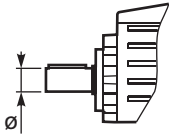

→ STANDARD

202A

S ⇒ Ø14
B ⇒ Ø16
D ⇒ Ø20
V ⇒ Ø25

302A

S ⇒ Ø14
B ⇒ Ø16
C ⇒ Ø19
D ⇒ Ø20
E ⇒ Ø24
V ⇒ Ø25
G ⇒ Ø28

402A 403A

B ⇒ Ø16
C ⇒ Ø19
D ⇒ Ø20
E ⇒ Ø24
V ⇒ Ø25

452A
502A 503A

E ⇒ Ø24
V ⇒ Ø25
G ⇒ Ø28
H ⇒ Ø30
I ⇒ Ø35

602A 603A

G ⇒ Ø28
H ⇒ Ø30
I ⇒ Ø35
L ⇒ Ø38
M ⇒ Ø40

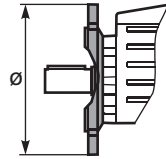

N Senza flangia
Without flange

202A 302A

1 ⇒ Ø120
2 ⇒ Ø140
3 ⇒ Ø160
4 ⇒ Ø200

402A 403A

1 ⇒ Ø120
2 ⇒ Ø140
3 ⇒ Ø160
4 ⇒ Ø200
5 ⇒ Ø250

452A
502A 503A

3 ⇒ Ø160
4 ⇒ Ø200
5 ⇒ Ø250

602A 603A

3 ⇒ Ø160
4 ⇒ Ø200
5 ⇒ Ø250

Standard Flange
Flangia Standard

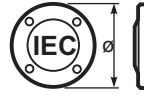

B5

B14

-A=56
(Ø120)

-O=56
(Ø80)

-B=63
(Ø140)

-P=63
(Ø90)

-C=71
(Ø160)

-Q=71
(Ø105)

-D=80
(Ø200)

-R=80
(Ø120)

-E=90
(Ø200)

-T=90
(Ø140)

-F=100+112
(Ø250)

-U=100+112
(Ø160)

-G=132
(Ø300)

-V=132
(Ø200)

Type R / Tipo R



202A 403A

302A 402A
503A 603A

-1 ⇒ Ø14

-2 ⇒ Ø19

452A 502A
602A

-3 ⇒ Ø24

Without flange / Senza flangia



202A 403A

302A 402A
503A 603A

-Z ⇒ Ø9
(56B5)

-1 ⇒ Ø14
(71B5)

-0 ⇒ Ø11
(63B5)

-2 ⇒ Ø19
(80B5)

-1 ⇒ Ø14
(71B5)

-3 ⇒ Ø24
(90B5)

452A 502A
602A

-2 ⇒ Ø19
(80B5)

-3 ⇒ Ø24
(90B5)

-4 ⇒ Ø28
(100B5)

→ STANDARD



A



B

STANDARD



C



D

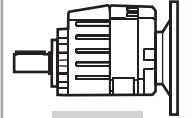

B3

STANDARD

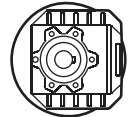

B6

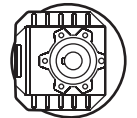

B7

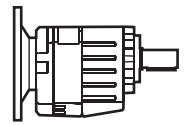

B8

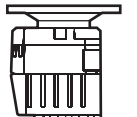

V5



V6

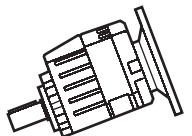

V8

Specify only for vertical positions

Specificare solo per posizione verticale

POTENZA RICHIESTA / REQUIRED POWER / ERFORDERLICHE LEISTUNG / PUISSANCE NECESSAIRE / POTENCIA NECESARIA

Lifting / sollevamento / hubantriebe / levage / elevación

$$P [KW] = \frac{M [Kg] \cdot g [9.81] \cdot v [m / s]}{1000}$$

Rotation / rotazione / drehung / rotation / rotação

$$P [KW] = \frac{M [Nm] \cdot n [rpm]}{9550}$$

Linear movement / traslazione / linearbewegung / translation / translación

$$P [KW] = \frac{F [N] \cdot v [m / s]}{1000}$$

TORQUE / COPPIA / DREHMOMENT / COUPLE / PAR

$$M [Nm] = \frac{9550 \cdot P[KW]}{n [rpm]}$$

$$M [lb in] = \frac{63030 \cdot P[HP]}{n [rpm]}$$

5

RADIAL LOADS / CARICHI RADIALI / RADIALE - UND AXIALLASTEN / CHARGES RADIALES / CARGA RADIAL Y AXIAL

- Radial load generated by external transmissions keyed onto input and/or output shafts.
- Forza radiale generata da organi di trasmissione calettati sugli alberi di ingresso e/o uscita.
- Belastungen der Antriebs- bzw. Abtriebswellen durch von aussen eingebrachte Radiallasten.
- Charge radiale générée par la transmissions calés sur les entrées et / ou des arbres de sortie
- Cargas radiales, generada por transmisiones externas, aplicadas sobre los ejes de entrada y/o salida

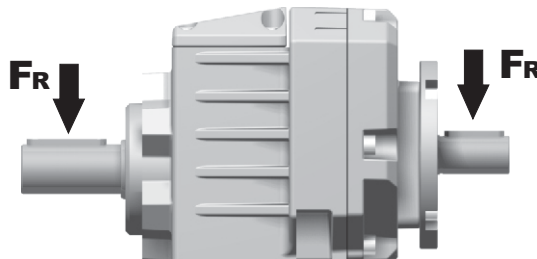

	$F_R [N] = \frac{M [Nm] \cdot 2000}{d [mm]} \cdot f_k$	$F_R [N] = \frac{M [lb in] \cdot 8.9}{d [in]} \cdot f_k$
M	Momento torcente / Output torque / Abtriebsdrehmoment / Couple / Par torsion	
d	Diametro primitivo / Diam. of driving element / Durchmesser der Abtriebseinheit / Diamètre primitif / Diámetro primitivo	
f_k	Coefficiente di trasformazione / Factor / Faktor / Coefficient de transmission / Coeficiente de transmisión 1.15 Ingranaggi / Gearwheels / Zahnrad / Engrenage / Engranaje 1.25 Catena / Chain sprockets / Antriebskette / Chaîne / Cadena 1.75 Cinghia Trapezoidale / Narrow v-belt pulley / Keilriemen / Courroie trap. / Correa trapezoidal 2.50 Cinghia piatta / Flat-belt pulley / Flachzahnriem. / Courroie crantée / Correa plana	

- If your application requires higher radial loads, contact our technical office. Higher load may be possible.
- Nel caso la vostra applicazione richieda carichi radiali superiori consultare il nostro ufficio tecnico, valori maggiori possono essere accettati.
- Wenn Ihre Anwendung höhere Radialbelastungen erfordert, so wenden Sie sich bitte an unser technischen Büro.
- Si votre application demande des charges radiales supérieures, s'adresser à notre bureau technique.
- En el caso en que una aplicación exija una carga radial superior a la especificada en el catálogo, consultar a nuestra oficinas técnica.

How to select a gearbox / Come selezionare un riduttore / Wie wählt man ein Getriebe
Comment sélectionner un réducteur / Cómo seleccionar un reductor

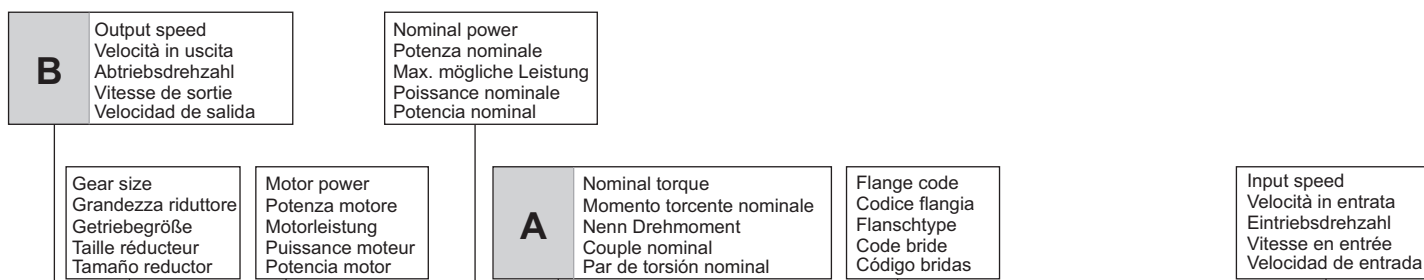

402A

**Coaxial - Gear
160Nm**

Rating - Aluminum COAXIAL GEARBOXES



QUICK SELECTION / Selezione veloce

input speed (n_1) = 1400 min⁻¹

Output Speed n_2 [min ⁻¹]	Ratio i	Motor power P_{1M} [kW]	Output torque M_{2M} [Nm]	Service factor f.s.	Nominal power P_{1R} [kW]	Nominal torque M_{2R} [Nm]	Available B5 motor flanges				Available B14 motor flanges				Output Shaft 	Notes Note Anmerkungen Note Notas
							B	C	D	E	Q	R	T	U		
398	3.52	3	69	1.2	3.5	80	B	71	80*	90*	C	C		100	2821	01
320	4.37	3	86	1.0	3.1	90	B				C	C		112	2818	02
252	5.55	3	109	0.9	2.8	100	B				C	C			2813	03
220	6.36	2.2	92	1.0	2.3	95	B				C	C			1921	04
191	7.33	2.2	106	1.1	2.5	120	B				C	C			2812	05

C Ratio
Rapporto
Untersetzung
Rapport de réduction
Relación

Output shaft diam.
Diam. albero uscita
Durchmesser abtriebswelle
Diametre arbre lent
Diametro eje de salida

Transmitted torque
Momento torcente trasmesso
Mögliche Drehmomente
Couple de sortie
Par transmitido

Service factor
Fattore di servizio
Betriebsfaktor
Facteur de service
Factor de servicio

Type of load and starts per hour Tipo di carico e avviamenti per ora		Oper. hours per day Ore di funz. giorn.		
		3 h	10 h	24 h
Continuous or intermittent appl. with start / hour Applicazione cont. o interm. con n.ro operazioni/ora	Uniform / Uniforme	0.8	1	1.25
	Moderate / Moderato	1	1.25	1.5
	Heavy / Forte	1.25	1.5	1.75
Intermittent application with start / hour Applicazione intermittente con n.ro operazioni/ora	Uniform / Uniforme	1	1.25	1.5
	Moderate / Moderato	1.25	1.5	1.75
	Heavy / Forte	1.5	1.75	2.15

D	Motor flange available Flange disponibili Erhältliche Motorflansche Brides disponibles Bridas disponibles	
B)	Mounting with reduction ring Montaggio con boccia di riduzione Reduzierhülsen Montage avec douille de réduction Montaje con casquillo de reducción	
C)	Motor flangeholes position/terminal box position Posizione fori flangia/basetta motore Bohrungsposition am Motorflansch/-sockel Position trous bride/barrette à bornes moteur Posición agujeros brida / base motor	
B)	Available without reduction bushes Disponibile anche senza boccia Auch ohne Reduzierbuchse verfügbar Disponible aussi sans douille de réduction Disponible tambien sin casquillo	

A	Select required torque (according to service factor)	Seleziona la coppia desiderata (comprensiva del fattore di servizio)	Max. Drehmoment in Bezug zum Betriebsfaktor	Sélectionner le couple souhaité (comprenant le facteur de service)	Seleccionar el par deseado (incluyendo el factor de servicio)
B	Select output speed	Seleziona la velocità in uscita	Ausgewählte Abtriebsdrehzahl	Sélectionner la vitesse de sortie	Seleccionar la velocidad de salida
C	On the same line of selected geared motor, you can find the gear ratio	Sulla riga corrispondente alla motorizzazione prescelta si può rilevare il rapporto di riduzione	Auf der gleichen Linie wie die ausgewählte Motorleistung steht auch die Getriebeuntersetzung	Sur la ligne correspondante à la motorisation pré-choisie on peut relever le rapport de réduction	En la línea correspondiente al motor preseleccionado es posible encontrar la relación de reducción
D	Select motor flange available (if requested)	Scegli la flangia disponibile (se richiesta)	Erhältliche Motorflansche (auf Anfrage)	Choisir la bride disponible (si elle est demandée)	Seleccionar la brida disponible (sobre pedido)



QUICK SELECTION / Selezione veloce The dynamic efficiency is **0.96** for all ratios **input speed (n₁) = 1400 min⁻¹**

Output Speed n ₂ [min ⁻¹]	Ratio i	Motor power P _{1M} [kW]	Output torque M _{2M} [Nm]	Service factor f.s.	Nominal power P _{1R} [kW]	Nominal torque M _{2R} [Nm]	Available B5 motor flanges		Available B14 motor flanges			Output Shaft 	Ratios code
							B	C	O	P	Q		
							63	71*	56	63	71		
407	3.44	0.55**	12	2.0	1.1	25			C	C		2821	01
327	4.28	0.55**	15	1.9	1.1	30			C	C		2818	02
257	5.45	0.55**	20	2.0	1.1	40			C	C		2815	03
225	6.23	0.55**	22	2.0	1.1	45			C	C		1921	04
194	7.20	0.55**	26	1.9	1.1	50			C	C		2812	05
181	7.74	0.55**	28	1.8	0.99	50			C	C		1918	06
142	9.85	0.55**	35	1.7	0.93	60			C	C		1915	07
123	11.42	0.55**	41	1.5	0.80	60			C	C		1715	08
107	13.03	0.55**	47	1.3	0.70	60			C	C		1912	09
93	15.10	0.37	37	1.6	0.61	60			C	C		1712	10
86	16.20	0.37	39	1.5	0.57	60			C	C		1910	11
75	18.78	0.37	46	1.3	0.49	60			C	C		1710	12
66	21.15	0.37	51	1.2	0.43	60			C	C		1312	13
64	21.84	0.37	53	1.1	0.42	60			C	C		1015	14
53	26.31	0.37	64	0.9	0.35	60			C	C		1310	15
48.5	28.88	0.37	70	1.0	0.37	70			C	C		1012	16
39	35.91	0.37	87	0.8	0.30	70			C	C		1010	17
37.1	37.69	0.25	62	1.1	0.28	70			C	C		912	18
29.9	46.87	0.25	77	0.9	0.23	70			C	C		910	19
28.1	49.76	0.25	81	0.9	0.21	70			C	C		712	20
22.6	61.89	0.18	73	1.0	0.17	70			C	C		710	21

** Concerning a reduced dimensions electric motor. * Nel montaggio P la flangia può superare l'ingombro massimo dei piedi. Eventualmente utilizzare la flangia B14 Riferito a motore con grandezza ridotta * In the P mounting the B5 motor flange can exceed the foot maximum dimensions. Possibly use the flange B14

A) Motor Flanges Available Flange Motore Disponibili **B) Supplied with Reduction Bushing** Fornito con Bussola di Riduzione **C) Available on Request without reduction bushing** Disponibile a Richiesta senza Bussola di Riduzione **D) Motor Flange Holes Position** Posizione Fori Flangia Motore

EN Unit **202A** is supplied with synthetic oil for lifetime lubrication, no maintenance is necessary. See table 1 for lubrication and recommended quantity. In table 2 please see possible radial loads and axial loads on the gearbox.

I Il riduttore **202A** viene fornito completo di olio sintetico per la lubrificazione permanente e non necessita di alcuna manutenzione. Vedi tab.1 per oli e quantità consigliati. In tab.2 sono presenti i carichi radiali e assiali applicabili al riduttore.

D Das Getriebe **202A** ist mit synthetischem Öl gefüllt und ist lebensdauergeschmiert. In Tabelle 1 ist die Schmiermenge und das empfohlene Schmiermittel angegeben. In Tabelle 2 sind die zulässigen Radial - und Axialbelastungen des Getriebes aufgeführt.

F Le réducteur **202A** est fourni complet avec de l'huile synthétique pour la lubrification permanente et ne nécessite aucun entretien. Voir tableau 1 concernant les huiles et les quantités conseillées. Les charges radiales et axiales applicables au réducteur sont précisées dans le tableau 2.

E El reductor tamaño **202A** se suministra, lubricado de por vida con aceite sintético y no requieren mantenimiento alguna. Ver tabla 1, para cantidades y aceites recomendados. En la tabla 2, se encuentran las cargas radiales y axiales admitidas por el reductor.

LUBRICATION 202A Oil Quantity 0.15 Lt.

AGIP Telium VSF 320 **SHELL** Omala S4 WE 320

For all details on lubrication and plugs check our website **tab. 1**
Per maggiori dettagli su lubrificazione e tappi olio vedi il nostro sito web

RADIAL AND AXIAL LOADS

Output shaft
Albero di uscita

$F_{eq} = F_R \cdot \frac{35.7}{X+20.7}$

Input shaft
Albero in entrata

n ₂	FA	FR	n ₂	FA	FR	n ₂	FA	FR
300	140	700	140	246	1320	70	340	1700
250	151	756	120	270	1350	40	380	1900
200	185	924	85	300	1500	15	-	-

n ₁	FA	FR
1400	140	700
900	160	800
500	190	950

tab. 2

Gearbox weight **3.3 kg**
 With flange
 peso riduttore **3.7 Kg**
 With feet

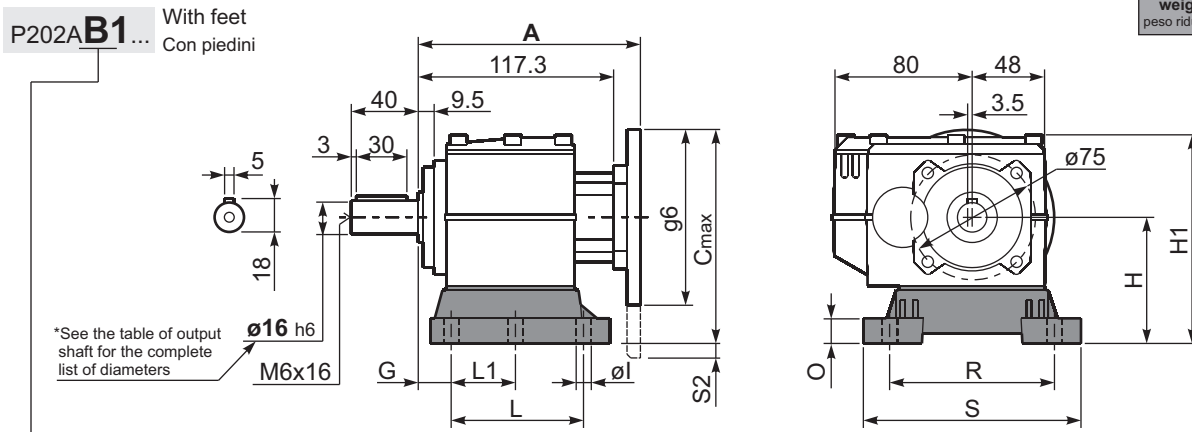

*See the table of output shaft for the complete list of diameters
 $\phi 16$ h6
 M6x16

Feet Code	Market reference	G	H	R	L	L1	S	H1	O	ø1	S2 only with motor flange	B5 max. Flange	kit code
B1	112	18	85	110	87	50	130	125	15	9	-	-	KC30.9.022
B2	212/3	18	100	130	107.5	60	155	145	5	11	-	-	KC30.9.023LM
S1	17-32	18	75	110	110	50	130	115.5	15	9	-	63B5	KC30.9.024
L3	03	12.5	65	91	60	-	105	149	5	9	11.5	71B5	KC30.9.026LM
L4	04	13	80	105	76	-	132	165	5	9	-	-	KC30.9.027LM

Other feet are available, see our web site
 Sono disponibili altri piedini, consulta il nostro sito web

A see on page bottom

Most popular types
 Tipi più diffusi

P202A-F... Output flanges
 flange di uscita

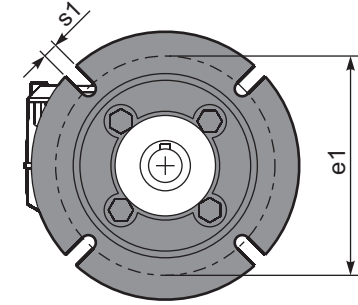
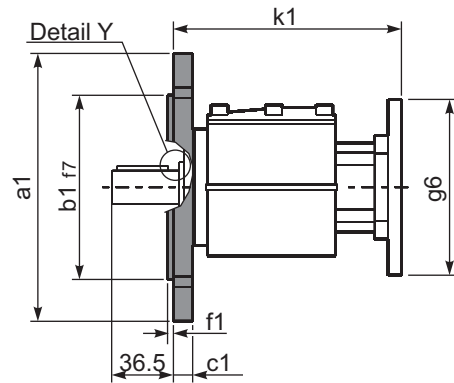
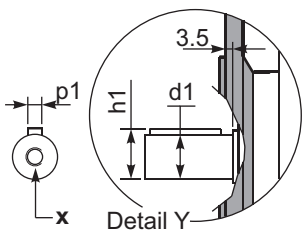

*Available output shaft / Albero di uscita

	Shaft - d1	p1	h1	x
Standard	$\phi 16 \times 40$	5	18	M6x16
On request A richiesta	$\phi 14 \times 30$	5	16	M6x16
	$\phi 20 \times 40$	6	22.5	M8x19
	$\phi 25 \times 50$	8	28	M8x19

Available output flanges / flange di uscita

a1 ø	b1	c1	e1	f1	s1	kit code
120	80	11.5	100	3	9*	KC30.9.010
140	95	11.5	115	3	9	KC30.9.011
160	110	11.5	130	3.5	9	KC30.9.012
200	130	11.5	165	3.5	11	KC30.9.013

* Holes position
 Posizione fori

With flange and feet only on request. Ask for compatibility

P202A-N... Basic gearbox
 Riduttore base

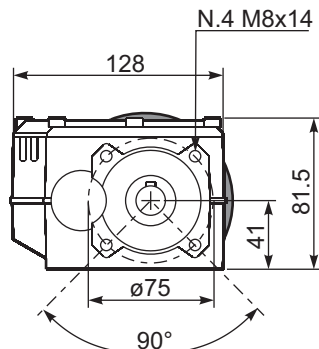
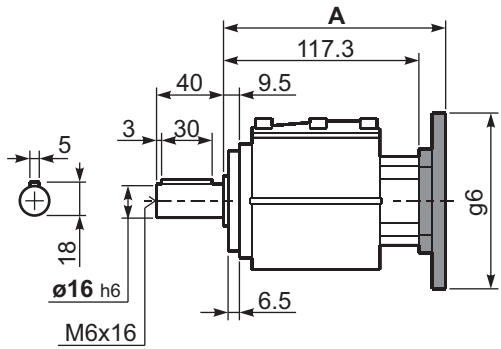

R202A-N... Input Shaft
 Albero in entrata

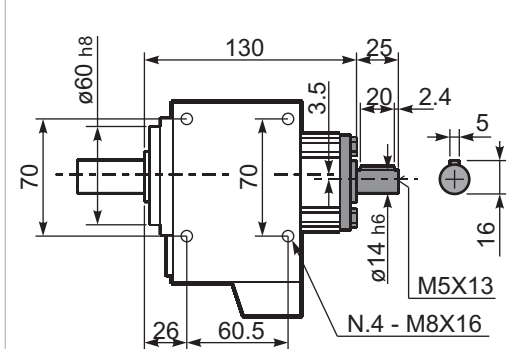

B5 Motor Flanges	A	C _{max}	g6	k1	kit code
63 B5	135.8	170	140	139.3	K050.4.041
71 B5	133.3	180	160	136.8	K050.4.042

B14 Motor Flanges	A	C _{max}	g6	k1	kit code
56 B14	133.3	139	80	136.8	KC40.4.049
63 B14	135.8	146	90	139.3	K050.4.047
71 B14	133.3	152.5	105	136.8	K050.4.045



QUICK SELECTION / Selezione veloce							input speed (n ₁) = 1400 min ⁻¹								
Output Speed n ₂ [min ⁻¹]	Ratio i	Motor power P _{1M} [kW]	Output torque M _{2M} [Nm]	Service factor f.s.	Nominal power P _{1R} [kW]	Nominal torque M _{2R} [Nm]	Available B5 motor flanges				Available B14 motor flanges			Output Shaft	Ratios code
							B	C	D	E	Q	R	T		
							63	71*	80*	90*	71	80	90		
407	3.44	1.5	34	1.0	1.5	35	B				C	C		2821	01
327	4.28	1.5	42	1.0	1.4	40	B				C	C		2818	02
257	5.45	1.5	54	1.0	1.4	52	B				C	C		2815	03
225	6.23	1.5	61	1.1	1.7	70	B				C	C		1921	04
194	7.20	1.5	71	1.0	1.5	70	B				C	C		2812	05
181	7.74	1.5	76	1.1	1.6	80	B				C	C		1918	06
142	9.85	1.5	97	1.0	1.5	95	B				C	C		1915	07
123	11.42	1.5	112	1.0	1.5	115	B				C	C		1715	08
107	13.03	1.1	94	1.2	1.3	114	B				C	C		1912	09
93	15.10	1.1	109	1.0	1.2	114	B				C	C		1712	10
86	16.20	0.75	80	1.3	1.0	107	B				C	C		1910	11
75	18.78	0.75	92	1.2	0.87	107	B				C	C		1710	12
66	21.15	0.75	104	1.1	0.82	114	B				C	C		1312	13
64	21.84	0.75	107	1.1	0.83	119	B				C	C		1015	14
53	26.31	0.55	95	1.1	0.62	107	B				C	C		1310	15
48.5	28.88	0.55	104	1.1	0.60	114	B				C	C		1012	16
39	35.91	0.37	87	1.2	0.46	107	B				C	C		1010	17
37.1	37.69	0.37	91	1.1	0.41	102	B				C	C		912	18
29.9	46.87	0.37	114	0.9	0.35	107	B				C	C		910	19
28.1	49.76	0.25	81	1.2	0.31	101	B				C	C		712	20
22.6	61.89	0.25	101	1.1	0.26	107	B				C	C		710	21

The dynamic efficiency is **0.96** for all ratios *Nel montaggio P la flangia può superare l'ingombro massimo dei piedi. Eventualmente utilizzare la flangia B14 * In the P mounting the B5 motor flange can exceed the foot maximum dimensions. Possibly use the flange B14

- A) Motor Flanges Available**
Flange Motore Disponibili
- B) Supplied with Reduction Bushing**
Fornito con Bussola di Riduzione
- C) Available on Request without reduction bushing**
Disponibile a Richiesta senza Bussola di Riduzione
- D) Motor Flange Holes Position**
Posizione Fori Flangia Motore

EN Unit **302A** is supplied with synthetic oil for lifetime lubrication, no maintenance is necessary. See table 1 for lubrication and recommended quantity. In table 2 please see possible radial loads and axial loads on the gearbox.

I Il riduttore **302A** viene fornito completo di olio sintetico per la lubrificazione permanente e non necessita di alcuna manutenzione. Vedi tab.1 per oli e quantità consigliati. In tab.2 sono presenti i carichi radiali e assiali applicabili al riduttore.

D Das Getriebe **302A** ist mit synthetischem Öl gefüllt und ist lebensdauergeschmiert. In Tabelle 1 ist die Schmiermenge und das empfohlene Schmiermittel angegeben. In Tabelle 2 sind die zulässigen Radial - und Axialbelastungen des Getriebes aufgeführt.

F Le réducteur **302A** est fourni complet avec de l'huile synthétique pour la lubrification permanente et ne nécessite aucun entretien. Voir tableau 1 concernant les huiles et les quantités conseillées. Les charges radiales et axiales applicables au réducteur sont précisées dans le tableau 2.

E El reductor tamaño **302A** se suministra, lubricado de por vida con aceite sintético y no requieren mantenimiento alguna. Ver tabla 1, para cantidades y aceites recomendados. En la tabla 2, se encuentran las cargas radiales y axiales admitidas por el reductor.

LUBRICATION 302A Oil Quantity 0.15 Lt.

AGIP Telium VSF 320 **SHELL** Omala S4 WE 320

For all details on lubrication and plugs check our website **tab. 1**
Per maggiori dettagli su lubrificazione e tappi olio vedi il nostro sito web

RADIAL AND AXIAL LOADS

Output shaft
Albero di uscita

$F_{eq} = F_R \cdot \frac{35.7}{X+20.7}$

Input shaft
Albero in entrata

n ₂	FA	FR	n ₂	FA	FR	n ₂	FA	FR
300	140	700	140	246	1320	70	340	1700
250	151	756	120	270	1350	40	380	1900
200	185	924	85	300	1500	15	-	-

n ₁	FA	FR
1400	226	1130
900	264	1320
500	322	1610

tab. 2

Gearbox weight **3.5 kg**
 With flange
 peso riduttore **4.0 Kg**
 With feet

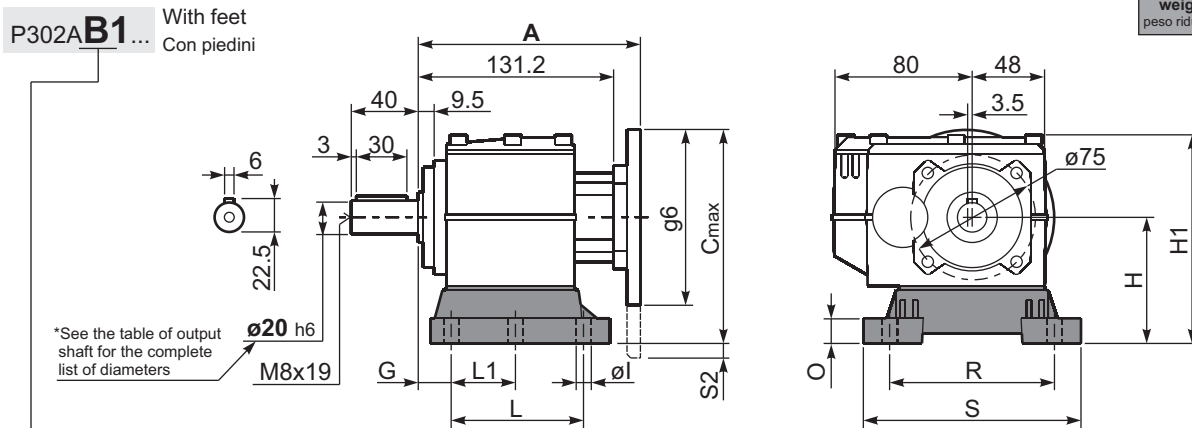

*See the table of output shaft for the complete list of diameters
 $\phi 20$ h6
 M8x19

Feet Code	Market reference	G	H	R	L	L1	S	H1	O	$\phi 1$	S2 only with motor flange	B5 max. Flange	kit code
B1	112	18	85	110	87	50	130	125	15	9	15 80/90B5	-	KC30.9.022
B2	212/3	18	100	130	107.5	60	155	145	5	11	3.5 80/90B5	-	KC30.9.023LM
S1	17-32	18	75	110	110	50	130	115.5	15	9	5 71B5	71B5	KC30.9.024
S2	27	25	90	110	130	-	130	135	5	9	-	71B5	KC30.9.025LM
L3	03	12.5	65	91	60	-	105	149	5	9	31.5 80/90B5	-	KC30.9.026LM
L4	04	13	80	105	76	-	132	165	5	9	16.5 80/90B5	-	KC30.9.027LM

Other feet are available, see our web site
 Sono disponibili altri piedini, consulta il nostro sito web

A see on page bottom

Most popular types
 Tipi più diffusi

P302A-F... Output flanges
 flange di uscita

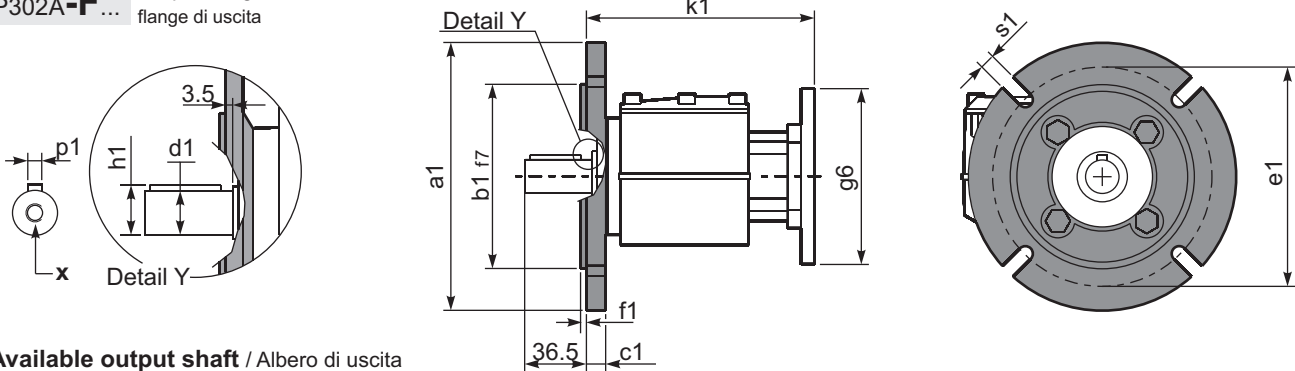

*Available output shaft / Albero di uscita

	Shaft - d1	p1	h1	x
Standard	$\phi 20 \times 40$	6	22.5	M8x19
On request A richiesta	$\phi 14 \times 30$	5	16	M6x16
	$\phi 16 \times 40$	5	18	M6x16
	$\phi 19 \times 40$	6	21.5	M6x16
	$\phi 24 \times 50$	8	27	M8x19
	$\phi 25 \times 50$	8	28	M8x19
	$\phi 28 \times 50$	8	31	M8x19

Available output flanges / flange di uscita

a1 ϕ	b1	c1	e1	f1	s1	kit code
120	80	11.5	100	3	9*	KC30.9.010
140	95	11.5	115	3	9	KC30.9.011
160	110	11.5	130	3.5	9	KC30.9.012
200	130	11.5	165	3.5	11	KC30.9.013

* Holes position
 Posizione fori

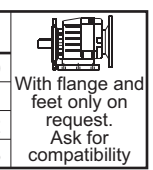

P302A-N... Basic gearbox
 Riduttore base

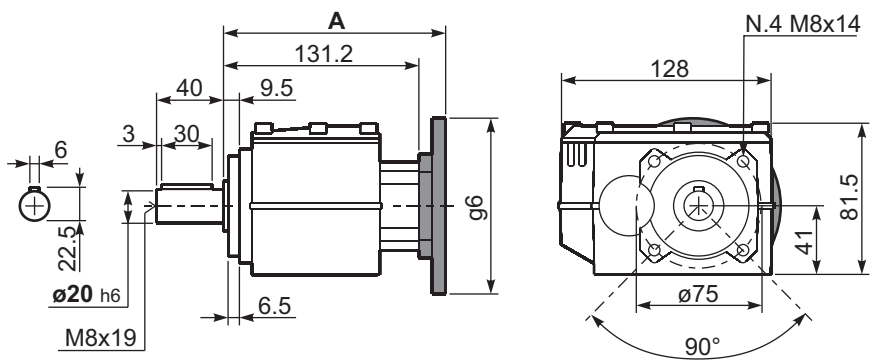

R302A-N... Input Shaft
 Albero in entrata

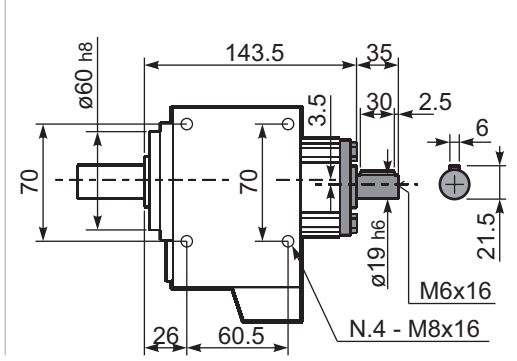

B5 Motor Flanges	A	C _{max}	g6	k1	kit code
63 B5	151.7	170	140	155.2	K063.4.041
71 B5	149.7	180	160	153.2	K063.4.042
80/90 B5	151.7	200	200	155.2	K063.4.043

B14 Motor Flanges	A	C _{max}	g6	k1	kit code
71 B14	149.7	152.5	105	153.2	K063.4.047
80 B14	151.7	160	120	155.2	K063.4.046
90 B14	151.7	170	140	155.2	K063.4.041



QUICK SELECTION / Selezione veloce

input speed (n_1) = 1400 min⁻¹

Output Speed n_2 [min ⁻¹]	Ratio i	Motor power P_{1M} [kW]	Output torque M_{2M} [Nm]	Service factor $f.s.$	Nominal power P_{1R} [kW]	Nominal torque M_{2R} [Nm]	Available B5 motor flanges					Available B14 motor flanges				Output Shaft		
							B	C	D	E	F	Q	R	T	U			Ratios code
							63	71	80*	90*	100*	71	80	90	100	112	100	
398	3.52	3	69	1.2	3.5	80	B					C	C			2821		01
320	4.37	3	86	1.0	3.1	90	B					C	C			2818		02
252	5.55	3	109	0.9	2.8	100	B					C	C			2813		03
220	6.36	2.2	92	1.0	2.3	95	B					C	C			1921		04
191	7.33	2.2	106	1.1	2.5	120	B					C	C			2812		05
177	7.89	2.2	114	1.1	2.3	120	B					C	C			1918		06
139	10.06	2.2	145	1.0	2.3	150	B					C	C			1913		08
120	11.66	1.5	114	1.5	2.3	174	B					C	C			1713	standard	09
106	13.26	1.5	130	1.2	1.8	160	B					C	C			1912	ø25	10
102	13.68	1.5	134	1.1	1.6	144	B					C	C			1513		25
91	15.37	1.5	151	1.1	1.6	160	B					C	C			1712	ø14	11
86	16.20	1.5	159	0.9	1.3	138	B					C	C			1910	ø16	12
78	18.04	1.5	177	0.9	1.4	160	B					C	C			1512	ø19	12
74	18.80	1.1	135	1.0	1.1	138	B					C	C			1710	ø20	23
65	21.54	1.1	155	1.0	1.1	160	B					C	C			1312	ø24	24
63	22.29	1.1	161	1.0	1.1	167	B					C	C			1013	On request	15
53	26.30	0.75	129	1.1	0.80	138	B					C	C			1310		16
47.6	29.40	0.75	144	1.1	0.83	160	B					C	C			1012		17
39	35.91	0.55	129	1.1	0.59	138	B					C	C			1010		18
36.5	38.37	0.55	138	1.2	0.64	160	B					C	C			912		19
29.9	46.86	0.55	169	0.8	0.45	138	B					C	C			910		20
27.6	50.67	0.37	123	1.1	0.40	132	B					C	C			712		21
22.6	61.88	0.37	150	0.9	0.34	138	B					C	C			710		22

The dynamic efficiency is **0.96** for all ratios

*Nel montaggio P la flangia può superare l'ingombro massimo dei piedi. Eventualmente utilizzare la flangia B14
* In the P mounting the B5 motor flange can exceed the foot maximum dimensions. Possibly use the flange B14

A Motor Flanges Available
Flange Motore Disponibili

B Supplied with Reduction Bushing
Fornito con Bussola di Riduzione

C Available on Request without reduction bushing
Disponibile a Richiesta senza Bussola di Riduzione

D Motor Flange Holes Position
Posizione Fori Flangia Motore

EN Unit **402A** is supplied with synthetic oil for lifetime lubrication, no maintenance is necessary. See table 1 for lubrication and recommended quantity. In table 2 please see possible radial loads and axial loads on the gearbox.

I Il riduttore **402A** viene fornito completo di olio sintetico per la lubrificazione permanente e non necessita di alcuna manutenzione. Vedi tab.1 per oli e quantità consigliati. In tab.2 sono presenti i carichi radiali e assiali applicabili al riduttore.

D Das Getriebe **402A** ist mit synthetischem Öl gefüllt und ist lebensdauergeschmiert. In Tabelle 1 ist die Schmiermenge und das empfohlene Schmiermittel angegeben. In Tabelle 2 sind die zulässigen Radial - und Axialbelastungen des Getriebes aufgeführt.

F Le réducteur **402A** est fourni complet avec de l'huile synthétique pour la lubrification permanente et ne nécessite aucun entretien. Voir tableau 1 concernant les huiles et les quantités conseillées. Les charges radiales et axiales applicables au réducteur sont précisées dans le tableau 2.

E El reductor tamaño **402A** se suministra, lubricado de por vida con aceite sintético y no requieren mantenimiento alguna. Ver tabla 1, para cantidades y aceites recomendados. En la tabla 2, se encuentran las cargas radiales y axiales admitidas por el reductor.

Standard supplied	For these mounting position specify in the order or add oil Per queste posizioni specificare in fase d'ordine o aggiungere olio					
B3	B6	B7	B8	V5	V6	V8
0.25 LT	0.30 LT	0.40 LT	0.40 LT	0.40 LT	0.50 LT	Ask
AGIP Telium VSF 320			SHELL Omala S4 WE 320			

For all details on lubrication and plugs check our website **tab. 1**
Per maggiori dettagli su lubrificazione e tappi olio vedi il nostro sito web

RADIAL AND AXIAL LOADS								
Output shaft Albero di uscita			$F_{eq} = F_R \cdot \frac{46}{X+21}$					
n_2	F_A	F_R	n_2	F_A	F_R	n_2	F_A	F_R
300	310	1550	140	406	2030	70	540	2700
250	330	1650	120	448	2240	40	600	3000
200	360	1800	85	480	2400	15	600	3000
Input shaft Albero di entrata								
n_1	F_A	F_R						
1400	240	1200						
900	280	1400						
500	340	1700						

tab. 2

P402A**B1** ... With feet
Con piedini

Gearbox weight **5.7 kg**
peso riduttore With flange
With feet **5.9 Kg**

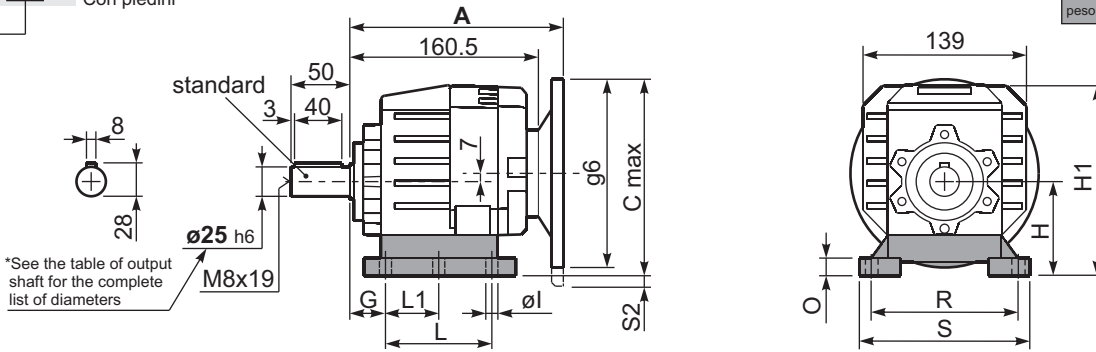

Feet / piedini

Feet Code	Market reference	G	H	R	L	L1	S	H1	O	øl	S2 only with motor flange	B5 max. Flange	kit code
B1	112	18	85	110	87	50	130	167	15	-	8/33 80/90B5 100/112B5	-	KC35.9.021
B2	212/3	18	100	130	107.5	60	155	182	17	11	18 100/112B5	-	KC40.9.025
S1	17	18	75	110	90+110	50	145	155	15	9	18/43 80/90B5 100/112B5	-	KC40.9.022
S2	27	25	90	110	130	-	145	172	20	9	3/28 80/90B5 100/112B5	-	KC40.9.024
H2	022-223	25	100	110	115	-	145	182	20	9	18 100/112B5	-	KC40.9.026
M1	42/3	25	80	110+120	85	-	145	162	15	9	13/38 80/90B5 100/112B5	-	KC40.9.023
L4	04	13	80	105	76	-	132	162	5	10	13/38 80/90B5 100/112B5	-	KC35.9.023LM
L5	05	16	100	125	90	-	150	182	6	12	18 100/112B5	-	KC40.9.027LM

Other feet are available, see our web site
Sono disponibili altri piedini, consulta il nostro sito web

A see on page bottom

Most popular types
Tipi più diffusi

P402A-**F** ... Output flanges
flange di uscita

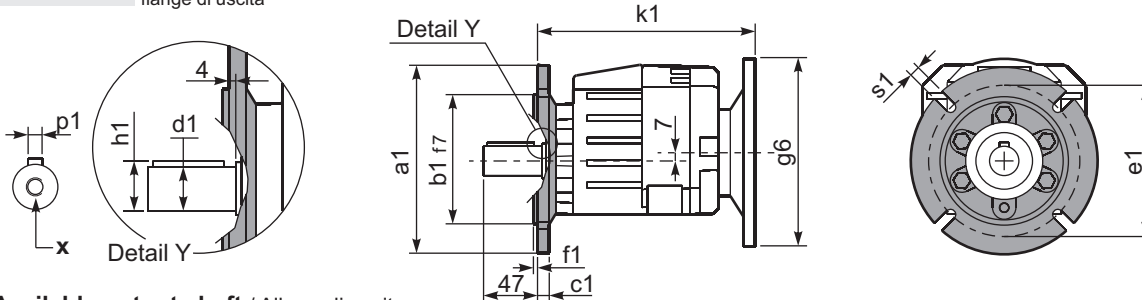

***Available output shaft / Albero di uscita**

	Shaft - d1	p1	h1	x
Standard	ø 25x50	8	28	M8x19
On request A richiesta	ø 16x40	5	18	M6x16
	ø 19x40	6	21.5	M6x16
	ø 20x40	6	22.5	M8x19
	ø 24x50	8	27	M8x19

Available output flanges / flange di uscita

a1 ø	b1	c1	e1	f1	s1	kit code
120	80	10	100	3	7	KC40.9.010
140	95	10	115	3	9	KC40.9.011
160	110	10	130	3	9	KC40.9.012
200	130	11	165	3.5	11	KC40.9.013
250	180	11.5	215	3.5	14	KC40.9.014

With flange and feet only on request. Ask for compatibility

P402A-**N** ... Basic gearbox
Riduttore base

R402A-**N** ... Input Shaft
Albero in entrata

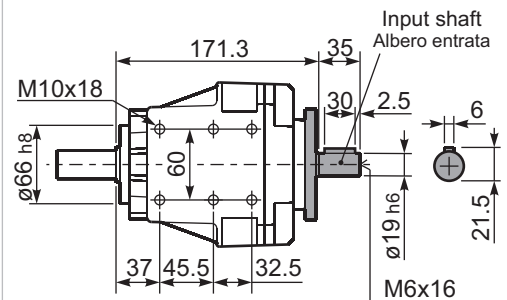
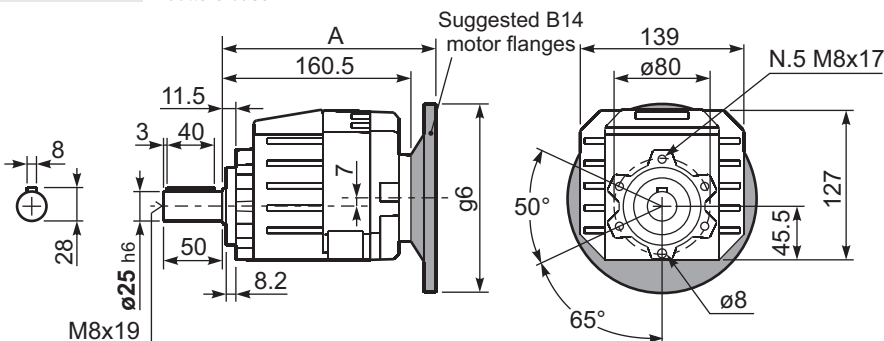

B5 Motor Flanges	A	C _{max}	g6	k1	kit code
63 B5	181	177	140	185	K063.4.041
71 B5	179	187	160	183	K063.4.042
80/90 B5	181	207	200	185	K063.4.043
100/112 B5	195.8	232	250	199.8	KC40.4.043

B14 Motor Flanges	A	C _{max}	g6	k1	kit code
71 B14	179	159.5	105	183	K063.4.047
80 B14	181	167	120	185	K063.4.046
90 B14	181	177	140	185	K063.4.041
100/112 B14	195.8	187	160	199.8	KC40.4.041



QUICK SELECTION / Selezione veloce

input speed (n_1) = 1400 min⁻¹

Output Speed n_2 [min ⁻¹]	Ratio i	Motor power P_{1M} [kW]	Output torque M_{2M} [Nm]	Service factor $f.s.$	Nominal power P_{1R} [kW]	Nominal torque M_{2R} [Nm]	Available B5 motor flanges		Available B14 motor flanges			Output Shaft \varnothing	Ratios code
							B	C	O	P	Q		
							63	71	56	63	71		
36.5	38.40	0.37	90	1.9	0.72	175			C	C		171713	02
32.0	43.69	0.37	103	1.5	0.54	149			C	C		191712	03
27.6	50.64	0.37	119	1.3	0.50	160			C	C		171712	04
26.2	53.36	0.37	125	1.1	0.41	138			C	C		191710	05
22.9	61.22	0.37	144	1.1	0.41	160			C	C		191312	06
22.6	61.90	0.37	146	0.9	0.35	138			C	C		171710	07
19.7	70.95	0.37	167	1.0	0.36	160			C	C		131712	08
19.1	73.43	0.37	172	1.0	0.38	175			C	C		101713	09
18.8	74.77	0.25	118	1.2	0.29	138			C	C		191310	10
16.1	86.66	0.25	138	1.0	0.25	138			C	C		131710	11
14.5	96.85	0.25	154	1.0	0.26	160			C	C		101712	12
13.6	102.89	0.25	163	1.1	0.28	180			C	C		101313	13
11.1	126.40	0.25	200	0.8	0.20	160			C	C		91712	17
10.3	135.69	0.25	215	0.7	0.19	160			C	C		101312	15
8.5	165.70	0.12	126	1.1	0.13	138			C	C		101310	16
7.9	177.09	0.12	135	1.2	0.14	160			C	C		91312	18
6.5	216.30	0.12	164	0.8	0.10	138			C	C		91310	19

The dynamic efficiency is **0.94** for all ratios

Motor Flanges Available
Flange Motore Disponibili

B) Supplied with Reduction Bushing
Fornito con Bussola di Riduzione

B) Available on Request without reduction bushing
Disponibile a Richiesta senza Bussola di Riduzione



C) Motor Flange Holes Position
Posizione Fori Flangia Motore

EN Unit **403A** is supplied with synthetic oil for lifetime lubrication, no maintenance is necessary. See table 1 for lubrication and recommended quantity. In table 2 please see possible radial loads and axial loads on the gearbox.

I Il riduttore **403A** viene fornito completo di olio sintetico per la lubrificazione permanente e non necessita di alcuna manutenzione. Vedi tab.1 per oli e quantità consigliati. In tab.2 sono presenti i carichi radiali e assiali applicabili al riduttore.

D Das Getriebe **403A** ist mit synthetischem Öl gefüllt und ist lebensdauergeschmiert. In Tabelle 1 ist die Schmiermenge und das empfohlene Schmiermittel angegeben. In Tabelle 2 sind die zulässigen Radial - und Axialbelastungen des Getriebes aufgeführt.

F Le réducteur **403A** est fourni complet avec de l'huile synthétique pour la lubrification permanente et ne nécessite aucun entretien. Voir tableau 1 concernant les huiles et les quantités conseillées. Les charges radiales et axiales applicables au réducteur sont précisées dans le tableau 2.

E El reductor tamaño **403A** se suministra, lubricado de por vida con aceite sintético y no requieren mantenimiento alguna. Ver tabla 1, para cantidades y aceites recomendados. En la tabla 2, se encuentran las cargas radiales y axiales admitidas por el reductor.

Standard supplied	For these mounting position specify in the order or add oil Per queste posizioni specificare in fase d'ordine o aggiungere olio					
0.30 LT	0.35 LT	0.45 LT	0.45 LT	0.45 LT	0.55 LT	Ask
AGIP Telium VSF 320			SHELL Omala S4 WE 320			

For all details on lubrication and plugs check our website **tab. 1**
Per maggiori dettagli su lubrificazione e tappi olio vedi il nostro sito web

RADIAL AND AXIAL LOADS								
Output shaft Albero di uscita			$F_{eq} = F_R \cdot \frac{46}{X+21}$					
n_2	F_A	F_R	n_2	F_A	F_R	n_2	F_A	F_R
300	310	1550	140	406	2030	70	540	2700
250	330	1650	120	448	2240	40	600	3000
200	360	1800	85	480	2400	15	600	3000
Input shaft Albero di entrata								
n_1	F_A	F_R						
1400	140	700						
900	160	800						
500	190	950						

tab. 2

3D dimensions on the Web

P403A **B1** ... With feet
Con piedini

Gearbox weight / peso riduttore: With flange **6.1 kg**
With feet **6.3 kg**

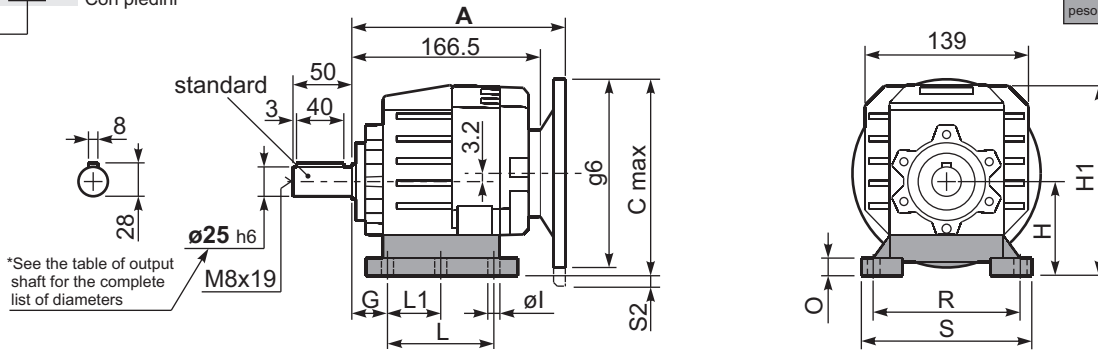

Feet / piedini

Feet Code	Market reference	G	H	R	L	L1	S	H1	O	øl	S2 only with motor flange	B5 max. Flange	kit code
B1	112	18	85	110	87	50	130	167	15	-	-	-	KC35.9.021
B2	212/3	18	100	130	107.5	60	155	182	17	11	-	-	KC40.9.025
S1	17	18	75	110	90+110	50	145	155	15	9	2 80/90B5	-	KC40.9.022
S2	27	25	90	110	130	-	145	172	20	9	-	-	KC40.9.024
H2	022-223	25	100	110	115	-	145	182	20	9	-	-	KC40.9.026
M1	42/3	25	80	110+120	85	-	145	162	15	9	-	-	KC40.9.023
L4	04	13	80	105	76	-	132	162	5	10	-	-	KC35.9.023LM
L5	05	16	100	125	90	-	150	182	6	12	-	-	KC40.9.027LM

Other feet are available, see our web site
Sono disponibili altri piedini, consulta il nostro sito web

A see on page bottom

Most popular types
Tipi più diffusi

P403A **-F** ... Output flanges
flange di uscita

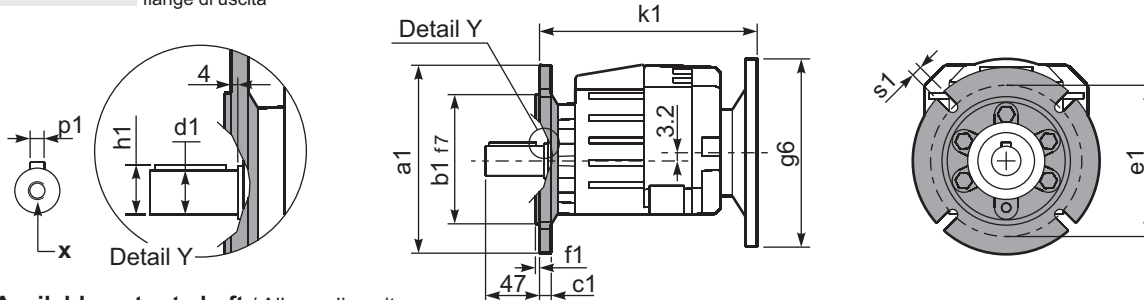

*Available output shaft / Albero di uscita

	Shaft - d1	p1	h1	x
Standard	ø 25x50	8	28	M8x19
On request A richiesta	ø 16x40	5	18	M6x16
	ø 19x40	6	21.5	M6x16
	ø 20x40	6	22.5	M8x19
	ø 24x50	8	27	M8x19

Available output flanges / flange di uscita

a1 ø	b1	c1	e1	f1	s1	kit code
120	80	10	100	3	7	KC40.9.010
140	95	10	115	3	9	KC40.9.011
160	110	10	130	3	9	KC40.9.012
200	130	11	165	3.5	11	KC40.9.013
250	180	11.5	215	3.5	14	KC40.9.014

With flange and feet only on request. Ask for compatibility

P403A **-N** ... Basic gearbox
Riduttore base

R403A **-N** ... Input Shaft
Albero in entrata

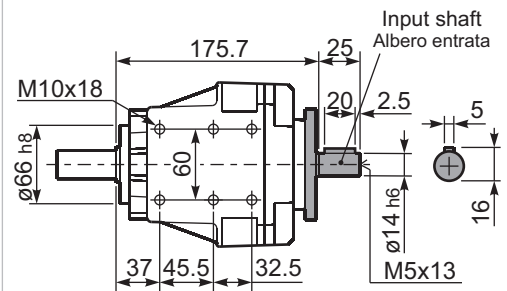
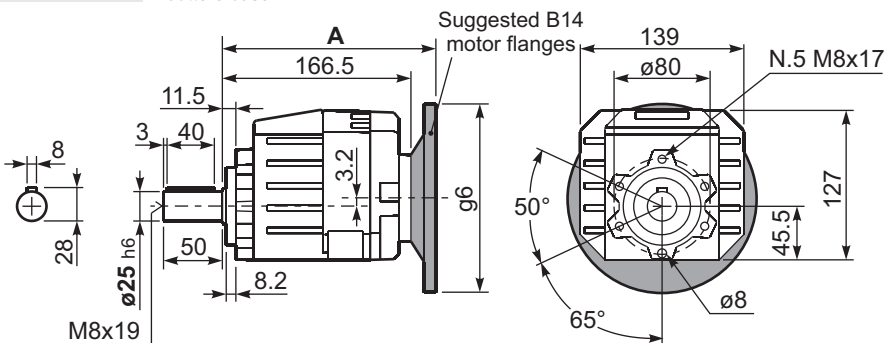

B5 Motor Flanges	A	C _{max}	g6	k1	kit code
63 B5	185	173.2	140	189	K050.4.041
71 B5	182.5	183.2	160	186.5	K050.4.042

B14 Motor Flanges	A	C _{max}	g6	k1	kit code
56 B14	182.5	143.2	80	186.5	KC40.4.049
63 B14	185	148.2	90	189	K050.4.047
71 B14	182.5	155.7	105	186.5	K050.4.045



QUICK SELECTION / Selezione veloce

input speed (n_1) = 1400 min⁻¹

Output Speed n_2 [min ⁻¹]	Ratio i	Motor power P_{1M} [kW]	Output torque M_{2M} [Nm]	Service factor f.s.	Nominal power P_{1R} [kW]	Nominal torque M_{2R} [Nm]	Available B5 motor flanges					Available B14 motor flanges				Output Shaft 	Ratios code
							C	D	E	F	G	R	T	U	V		
							71	80	90	100* 112	132*	80	90	100 112	132		
388	3.61	4	95	1.6	6.3	150	B									3018	01
331	4.23	4	111	1.5	6.1	170	B									3016	02
279	5.01	4	131	1.5	6.1	200	B									3014	03
231	6.07	4	159	1.6	6.3	250	B									3012	04
206	6.81	4	178	1.6	6.2	277	B									2018	05
176	7.96	4	209	1.4	5.8	300	B									2016	06
148	9.45	4	248	1.2	4.9	304	B									2014	07
122	11.43	4	299	1.0	4.0	300	B									2012	08
99	14.21	3	279	0.9	2.8	265	B									2010	09
84	16.62	3	327	0.9	2.8	304	B									1314	10
70	20.10	2.2	290	1.0	2.3	300	B									1312	11
56	24.98	1.85	303	0.9	1.6	265	B									1310	12
47.6	29.41	1.5	289	1.1	1.6	304	B									814	13
39.3	35.58	1.5	349	0.9	1.3	300	B									812	14
34.6	40.50	1.1	292	1.0	1.1	290	B									614	15
31.7	44.22	1.1	319	0.8	0.92	265	B									810	16
28.6	49.00	0.75	241	1.2	0.93	300	B									612	17
23.0	60.90	0.75	299	0.9	0.66	265	B									610	18

The dynamic efficiency is **0.96** for all ratios *Nel montaggio P la flangia può superare l'ingombro massimo dei piedi. Eventualmente utilizzare la flangia B14
* In the P mounting the B5 motor flange can exceed the foot maximum dimensions. Possibly use the flange B14

Motor Flanges Available
Flange Motore Disponibili

B) Supplied with Reduction Bushing
Fornito con Bussola di Riduzione

B) Available on Request without reduction bushing
Disponibile a Richiesta senza Bussola di Riduzione

C) Motor Flange Holes Position
Posizione Fori Flangia Motore

EN Unit **452A** is supplied with synthetic oil for lifetime lubrication, no maintenance is necessary. See table 1 for lubrication and recommended quantity. In table 2 please see possible radial loads and axial loads on the gearbox.

I Il riduttore **452A** viene fornito completo di olio sintetico per la lubrificazione permanente e non necessita di alcuna manutenzione. Vedi tab.1 per oli e quantità consigliati. In tab.2 sono presenti i carichi radiali e assiali applicabili al riduttore.

D Das Getriebe **452A** ist mit synthetischem Öl gefüllt und ist lebensdauergeschmiert. In Tabelle 1 ist die Schmiermenge und das empfohlene Schmiermittel angegeben. In Tabelle 2 sind die zulässigen Radial- und Axialbelastungen des Getriebes aufgeführt.

F Le réducteur **452A** est fourni complet avec de l'huile synthétique pour la lubrification permanente et ne nécessite aucun entretien. Voir tableau 1 concernant les huiles et les quantités conseillées. Les charges radiales et axiales applicables au réducteur sont précisées dans le tableau 2.

E El reductor tamaño **452A** se suministra, lubricado de por vida con aceite sintético y no requieren mantenimiento alguna. Ver tabla 1, para cantidades y aceites recomendados. En la tabla 2, se encuentran las cargas radiales y axiales admitidas por el reductor.

Standard supplied	For these mounting position specify in the order or add oil Per queste posizioni specificare in fase d'ordine o aggiungere olio					
0.31 LT	0.31 LT	0.31 LT	0.31 LT	0.31 LT	0.31 LT	Ask
AGIP Telium VSF 320			SHELL Omala S4 WE 320			

For all details on lubrication and plugs check our website **tab. 1**
Per maggiori dettagli su lubrificazione e tappi olio vedi il nostro sito web

RADIAL AND AXIAL LOADS								
Output shaft / Albero di uscita			Input shaft / Albero in entrata			Equation		
	F_R (N)	F_A (N)		F_R (N)	F_A (N)	$F_{eq} = F_R \cdot \frac{51}{X+21}$		
n_2	FA	FR	n_2	FA	FR	n_2	FA	FR
300	415	2070	140	540	2700	70	700	3510
250	430	2160	120	560	2790	40	810	4050
200	470	2340	85	630	3150	15	900	4500
Input shaft / Albero in entrata				F_R (N)	F_A (N)	n_1	FA	FR
						1400	400	2000
						900	440	2200
						500	440	2200

tab. 2

P452A B1... With feet
Con piedini

Gearbox weight With flange **8.7 kg**
peso riduttore With feet **8.9 Kg**

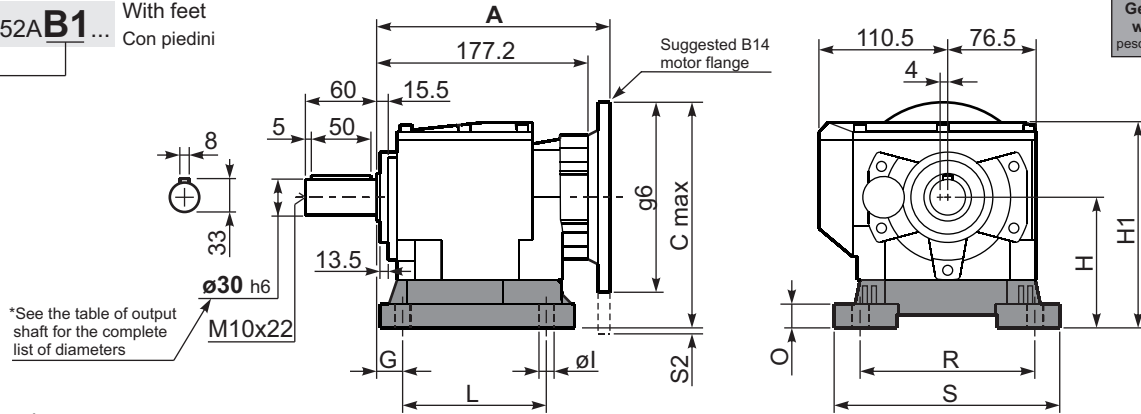

Feet / piedini

Feet Code	Market reference	G	H	R	L	S	H1	O	øl	S2 only with motor flange	B5 max. Flange	kit code
B3	312/3	18	110	160	130	190	162	20	11	15 100/112B5 40 132B5	-	KC50.9.024
B4	30/35	20	130	180	149.5	216	182	18	14	20 132B5	-	KC60.9.024
S4	47-57	30	115	135	165	170	167	24	13.5	-	80/90B5	KC50.9.022
H3	023-233	30	130	135	135	185	231.5	25	14	20 132B5	-	KC50.9.025
M2	52/3	30	110	135+150	100	190	162	18	11	15 100/112B5 40 132B5	-	KC50.9.023
L6	06	19	125	160	106	205	177	8	14	25 132B5	-	KC50.9.026LM
E2	2202/3	13	100	135	192	164	152	6	14	-	71B5	KC50.9.027LM
P4	142	35	142	130	145	160	194	8	14	8 132B5	-	KC50.9.028LM

Other feet are available, see our web site
Sono disponibili altri piedini, consulta il nostro sito web

A see on page bottom

Most popular types
Tipi più diffusi

P452A-F... Output flanges
flange di uscita

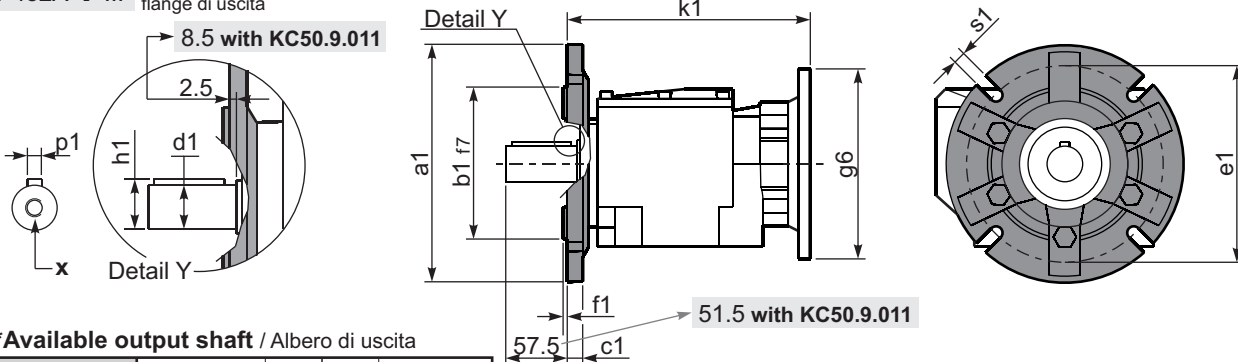

*Available output shaft / Alberi di uscita

	Shaft - d1	p1	h1	x
Standard	ø 30x60	8	33	M10x22
On request A richiesta	ø 24x50	8	27	M8x19
	ø 25x50	8	28	M8x19
	ø 28x60	8	31	M8x19
	ø 35x60	10	38	M10x22

Available output flanges / flange di uscita

a1 ø	b1	c1	e1	f1	s1	kit code
160	110	14	130	3.5	11	KC50.9.011
200	130	13	165	3.5	11	KC50.9.012
250	180	15.5	215	4	14	KC50.9.013

With flange and feet only on request. Ask for compatibility

P452A-N... Basic gearbox
Riduttore base

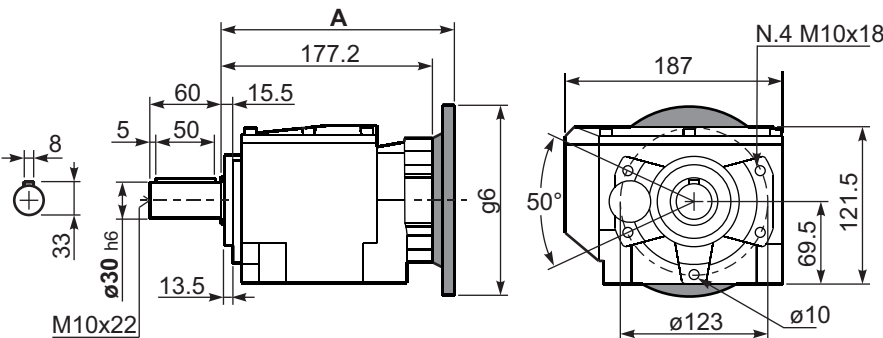

R452A-N... Input Shaft
Albero in entrata

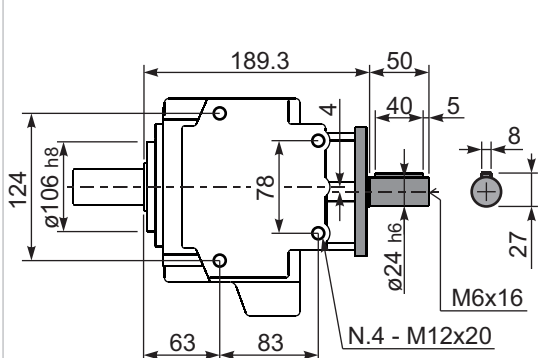

B5 Motor Flanges	A	C _{max}	g6	k1	kit code	k1 with KC50.9.011	B14 Motor Flanges	A	C _{max}	g6	k1	kit code	k1 with KC50.9.011
71 B5	195.7	222	160	198.2	KC023.4.041	204.2	80 B14	197.7	202	120	200.2	KC085.4.046	206.2
80/90 B5	197.7	242	200	200.2	KC023.4.042	206.2	90 B14	197.7	212	140	200.2	KC085.4.045	206.2
100/112 B5	206.7	267	250	209.2	KC023.4.043	215.2	100/112 B14	206.7	222	160	209.2	KC085.4.047	215.2
132 B5	224.7	292	300	227.2	KC50.4.043	233.2	132 B14	224.7	242	200	227.2	KC50.4.041	233.2



QUICK SELECTION / Selezione veloce

input speed (n_1) = 1400 min⁻¹

Output Speed n_2 [min ⁻¹]	Ratio i	Motor power P_{1M} [kW]	Output torque M_{2M} [Nm]	Service factor $f.s.$	Nominal power P_{1R} [kW]	Nominal torque M_{2R} [Nm]	Available B5 motor flanges					Available B14 motor flanges				Output Shaft 	Ratios code
							C	D	E	F	G	R	T	U	V		
							71	80	90	100* 112	132*	80	90	100 112	132		
388	3.61	5.5	130	1.2	6.3	150	B									3018	01
331	4.23	5.5	152	1.1	6.1	170	B									3016	02
279	5.01	5.5	180	1.1	6.1	200	B									3014	03
231	6.07	5.5	219	1.1	6.3	250	B									3012	04
206	6.81	5.5	245	1.2	6.7	300	B									2018	05
176	7.96	5.5	287	1.2	6.3	330	B									2016	07
148	9.45	5.5	340	1.0	5.7	354	B									2014	08
122	11.43	4	299	1.1	4.4	326	B									2012	09
99	14.21	3	279	0.9	2.7	250	B									2010	10
84	16.62	3	327	1.1	3.3	354	B									1314	11
70	20.10	2.2	290	1.1	2.5	326	B									1312	12
57	24.61	2.2	354	0.9	2.0	326	B									1112	20
56	24.98	1.5	245	1.0	1.5	250	B									1310	13
47.6	29.41	1.5	289	1.2	1.8	354	B									814	14
39.3	35.58	1.5	349	0.9	1.4	326	B									812	15
34.6	40.50	1.1	292	1.0	1.1	295	B									614	16
31.7	44.23	1.1	319	0.8	0.86	250	B									810	17
28.6	49.00	1.1	353	0.9	1.0	326	B									612	18
23.0	60.90	0.75	299	0.8	0.63	250	B									610	19

The dynamic efficiency is **0.96** for all ratios

*Nel montaggio P la flangia può superare l'ingombro massimo dei piedi. Eventualmente utilizzare la flangia B14
* In the P mounting the B5 motor flange can exceed the foot maximum dimensions. Possibly use the flange B14

Motor Flanges Available
Flange Motore Disponibili

B) Supplied with Reduction Bushing
Fornito con Bussola di Riduzione

B) Available on Request without reduction bushing
Disponibile a Richiesta senza Bussola di Riduzione

C) Motor Flange Holes Position
Posizione Fori Flangia Motore

EN Unit **502A** is supplied with synthetic oil for lifetime lubrication, no maintenance is necessary. See table 1 for lubrication and recommended quantity. In table 2 please see possible radial loads and axial loads on the gearbox.

I Il riduttore **502A** viene fornito completo di olio sintetico per la lubrificazione permanente e non necessita di alcuna manutenzione. Vedi tab.1 per oli e quantità consigliati. In tab.2 sono presenti i carichi radiali e assiali applicabili al riduttore.

D Das Getriebe **502A** ist mit synthetischem Öl gefüllt und ist lebensdauer geschmiert. In Tabelle 1 ist die Schmiermenge und das empfohlene Schmiermittel angegeben. In Tabelle 2 sind die zulässigen Radial - und Axialbelastungen des Getriebes aufgeführt.

F Le réducteur **502A** est fourni complet avec de l'huile synthétique pour la lubrification permanente et ne nécessite aucun entretien. Voir tableau 1 concernant les huiles et les quantités conseillées. Les charges radiales et axiales applicables au réducteur sont précisées dans le tableau 2.

E El reductor tamaño **502A** se suministra, lubricado de por vida con aceite sintético y no requieren mantenimiento alguna. Ver tabla 1, para cantidades y aceites recomendados. En la tabla 2, se encuentran las cargas radiales y axiales admitidas por el reductor.

Standard supplied	For these mounting position specify in the order or add oil Per queste posizioni specificare in fase d'ordine o aggiungere olio					
B3	B6	B7	B8	V5	V6	V8
0.45 LT	0.55 LT	1.00 LT	1.10 LT	1.10 LT	1.15 LT	Ask
AGIP Telium VSF 320			SHELL Omala S4 WE 320			

For all details on lubrication and plugs check our website **tab. 1**
Per maggiori dettagli su lubrificazione e tappi olio vedi il nostro sito web

RADIAL AND AXIAL LOADS								
Output shaft Albero di uscita			$F_{eq} = FR \cdot \frac{54}{X+24}$					
n_2	FA	FR	n_2	FA	FR	n_2	FA	FR
300	460	2300	140	600	3000	70	780	3900
250	480	2400	120	620	3100	40	900	4500
200	520	2600	85	700	3500	15	1000	5000
Input shaft Albero in entrata								
n_1	FA	FR						
1400	400	2000						
900	440	2200						
500	440	2200						

tab. 2

P502A **B1** ... With feet
Con piedini

Gearbox weight **11.7 kg**
peso riduttore With feet **11.9 Kg**

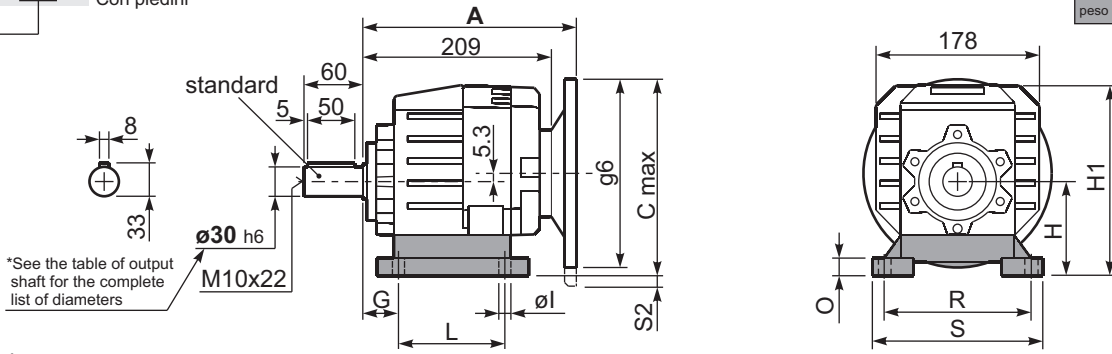

Feet / piedini

Feet Code	Market reference	G	H	R	L	S	H1	O	øl	S2 only with motor flange	B5 max. Flange	kit code
B3	312/3	18	110	160	130	190	211.5	20	11	10 100/112B5 35 132B5	-	KC50.9.024
B4	30/35	20	130	180	149.5	216	231.5	18	14	15 132B5	-	KC60.9.024
S4	47-57	30	115	135	165	170	216.5	24	13.5	5 100/112B5 30 132B5	-	KC50.9.022
H3	023-233	30	130	135	135	185	231.5	25	14	15 132B5	-	KC50.9.025
M2	52/3	30	110	135-150	100	190	226.5	18	11	10 100/112B5 35 132B5	-	KC50.9.023
L6	06	19	125	160	106	205	201.5	8	14	20 132B5	-	KC50.9.026LM
E2	2202/3	13	100	135	192	164	201.5	6	14	20 100/112B5 45 132B5	-	KC50.9.027LM
P4	142	35	142	130	145	160	243.5	8	14	3 132B5	-	KC50.9.028LM

Other feet are available, see our web site
Sono disponibili altri piedini, consulta il nostro sito web

A see on page bottom

Most popular types
Tipi più diffusi

P502A-**F** ... Output flanges
flange di uscita

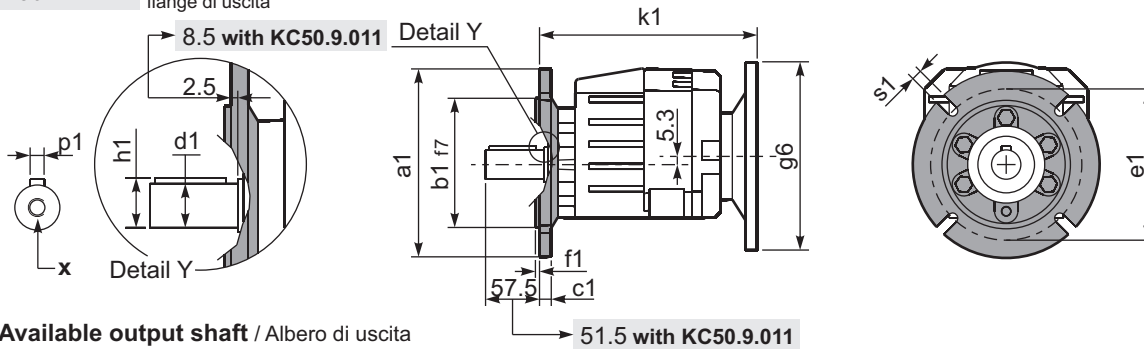

***Available output shaft / Alberi di uscita**

	Shaft - d1	p1	h1	x
Standard	ø 30x60	8	33	M10x22
On request A richiesta	ø 24x50	8	27	M8x19
	ø 25x50	8	28	M8x19
	ø 28x60	8	31	M8x19
	ø 35x60	10	38	M10x22

Available output flanges / flange di uscita

a1 ø	b1	c1	e1	f1	s1	kit code
160	110	14	130	3.5	11	KC50.9.011
200	130	13	165	3.5	11	KC50.9.012
250	180	15.5	215	4	14	KC50.9.013

With flange and feet only on request. Ask for compatibility

P502A-**N** ... Basic gearbox
Riduttore base

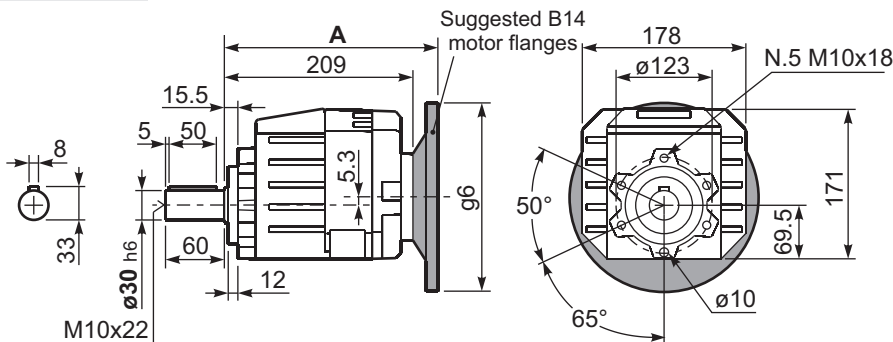

R502A-N ... Input Shaft
Albero in entrata

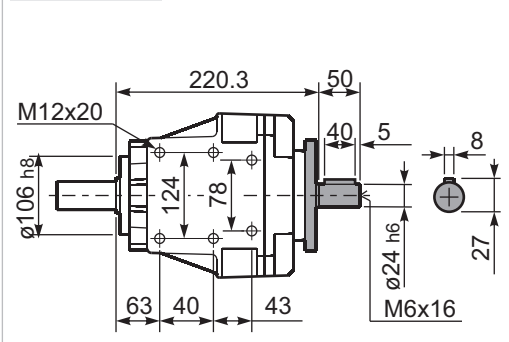

B5 Motor Flanges	A	C _{max}	g6	k1	kit code	k1 with KC50.9.011	B14 Motor Flanges	A	C _{max}	g6	k1	kit code	k1 with KC50.9.011
71 B5	227.5	227.3	160	230	KC023.4.041	236	80 B14	229.5	207.3	120	232	KC085.4.046	238
80/90 B5	229.5	247.3	200	232	KC023.4.042	238	90 B14	229.5	217.3	140	232	KC085.4.045	238
100/112 B5	238.5	272.3	250	241	KC023.4.043	247	100/112 B14	238.5	227.3	160	241	KC085.4.047	247
132 B5	256.5	297.3	300	259	KC50.4.043	265	132 B14	256.5	247	200	259	KC50.4.041	265



QUICK SELECTION / Selezione veloce							input speed (n ₁) = 1400 min ⁻¹								
Output Speed n ₂ [min ⁻¹]	Ratio i	Motor power P _{1M} [kW]	Output torque M _{2M} [Nm]	Service factor f.s.	Nominal power P _{1R} [kW]	Nominal torque M _{2R} [Nm]	Available B5 motor flanges				Available B14 motor flanges			Output Shaft	Ratios code
							B	C	D	E	Q	R	T		
							63	71	80	90	71	80	90		
35.2	39.79	1.1	278	1.3	1.5	373	B				C	C		191316	01
29.6	47.22	1.1	330	1.1	1.2	354	B				C	C		191314	02
25.6	54.73	1.1	382	0.9	1.0	354	B				C	C		171314	03
21.1	66.22	0.75	315	1.0	0.78	326	B				C	C		171312	04
18.3	76.69	0.75	365	1.0	0.73	354	B				C	C		131314	05
16.7	83.59	0.55	292	1.2	0.67	354	B				C	C		190814	06
15.1	92.78	0.55	324	1.0	0.55	326	B				C	C		131312	07
13.4	104.67	0.55	365	1.0	0.53	354	B				C	C		101314	08
11.9	117.22	0.37	275	1.2	0.44	326	B				C	C		170812	09
11.1	126.65	0.37	297	1.1	0.41	326	B				C	C		101312	10
10.2	136.62	0.37	321	1.1	0.41	354	B				C	C		91314	11
8.5	165.29	0.25	262	1.2	0.31	326	B				C	C		91312	12
7.8	180.40	0.25	286	1.2	0.31	354	B				C	C		71314	13
6.4	218.26	0.25	346	0.9	0.24	326	B				C	C		171312	14
5.8	241.82	0.25	384	0.9	0.23	354	B				C	C		90814	15
4.8	292.57	0.18	334	1.0	0.18	326	B				C	C		90812	16
4.4	319.32	0.18	365	1.0	0.17	354	B				C	C		70814	17
3.6	386.33	0.18	441	0.7	0.13	326	B				C	C		70812	18
2.9	480.16	0.18	548	0.5	0.08	250	B				C	C		70810	19

The dynamic efficiency is **0.94** for all ratios

Motor Flanges Available Flange Motore Disponibili
 B Supplied with Reduction Bushing Fornito con Bussola di Riduzione
 B Available on Request without reduction bushing Disponibile a Richiesta senza Bussola di Riduzione
 C Motor Flange Holes Position Posizione Fori Flangia Motore

EN Unit **503A** is supplied with synthetic oil for lifetime lubrication, no maintenance is necessary. See table 1 for lubrication and recommended quantity. In table 2 please see possible radial loads and axial loads on the gearbox.

I Il riduttore **503A** viene fornito completo di olio sintetico per la lubrificazione permanente e non necessita di alcuna manutenzione. Vedi tab.1 per oli e quantità consigliati. In tab.2 sono presenti i carichi radiali e assiali applicabili al riduttore.

D Das Getriebe **503A** ist mit synthetischem Öl gefüllt und ist lebensdauergeschmiert. In Tabelle 1 ist die Schmiermenge und das empfohlene Schmiermittel angegeben. In Tabelle 2 sind die zulässigen Radial - und Axialbelastungen des Getriebes aufgeführt.

F Le réducteur **503A** est fourni complet avec de l'huile synthétique pour la lubrification permanente et ne nécessite aucun entretien. Voir tableau 1 concernant les huiles et les quantités conseillées. Les charges radiales et axiales applicables au réducteur sont précisées dans le tableau 2.

E El reductor tamaño **503A** se suministra, lubricado de por vida con aceite sintético y no requieren mantenimiento alguna. Ver tabla 1, para cantidades y aceites recomendados. En la tabla 2, se encuentran las cargas radiales y axiales admitidas por el reductor.

Standard supplied	For these mounting position specify in the order or add oil Per queste posizioni specificare in fase d'ordine o aggiungere olio					
0.75 LT	0.75 LT	1.05 LT	1.15 LT	1.20 LT	1.20 LT	Ask
AGIP Telium VSF 320			SHELL Omala S4 WE 320			

For all details on lubrication and plugs check our website **tab. 1**
Per maggiori dettagli su lubrificazione e tappi olio vedi il nostro sito web

RADIAL AND AXIAL LOADS								
Output shaft Albero di uscita			$F_{eq} = F_R \cdot \frac{54}{X+24}$					
n ₂	FA	FR	n ₂	FA	FR	n ₂	FA	FR
300	460	2300	140	600	3000	70	780	3900
250	480	2400	120	620	3100	40	900	4500
200	520	2600	85	700	3500	15	1000	5000
Input shaft Albero in entrata								
n ₁	FA	FR						
1400	400	2000						
900	440	2200						
500	440	2200						

tab. 2



QUICK SELECTION / Selezione veloce

input speed (n₁) = 1400 min⁻¹

Output Speed n ₂ [min ⁻¹]	Ratio i	Motor power P _{1M} [kW]	Output torque M _{2M} [Nm]	Service factor f.s.	Nominal power P _{1R} [kW]	Nominal torque M _{2R} [Nm]	Available B5 motor flanges					Available B14 motor flanges				Output Shaft 	Ratios code	
							C	D	E	F	G	R	T	U	V			
							71	80	90	100 112	132*	80	90	100 112	132			
388	3.61	7.5	171	1.1	7.6	180	B										3018	01
331	4.23	7.5	200	1.1	8.0	220	B										3016	02
279	5.01	7.5	238	1.1	7.9	260	B										3014	03
231	6.07	7.5	288	1.0	7.6	300	B										3012	04
206	6.81	7.5	323	1.1	7.9	350	B										2018	05
176	7.96	7.5	378	1.0	7.1	370	B										2016	07
148	9.45	5.5	331	1.2	6.5	400	B										2014	08
122	11.43	5.5	401	1.0	5.5	415	B										2012	09
100	14.00	4	359	1.2	4.7	435	B										1316	10
84	16.62	4	426	1.2	4.7	515	B										1314	11
70	20.10	4	515	1.0	4.0	520	B										1312	12
57	24.61	3	475	1.1	3.2	520	B										1112	20
47.6	29.41	2.2	418	1.1	2.3	450	B										814	14
39.3	35.58	1.85	431	1.2	2.2	520	B										812	15
34.6	40.50	1.1	290	1.1	1.2	320	B										614	16
31.7	44.23	1.5	433	0.9	1.4	400	B										810	17
28.6	49.00	1.1	351	1.1	1.2	400	B										612	18
23.0	60.90	1.1	436	0.9	1.0	400	B										610	19

The dynamic efficiency is **0.96** for all ratios

*Nel montaggio P la flangia può superare l'ingombro massimo dei piedi. Eventualmente utilizzare la flangia B14
* In the P mounting the B5 motor flange can exceed the foot maximum dimensions. Possibly use the flange B14

A Motor Flanges Available
Flange Motore Disponibili

B Supplied with Reduction Bushing
Fornito con Bussola di Riduzione

C Available on Request without reduction bushing
Disponibile a Richiesta senza Bussola di Riduzione

D Motor Flange Holes Position
Posizione Fori Flangia Motore

EN Unit **602A** is supplied with synthetic oil for lifetime lubrication, no maintenance is necessary. See table 1 for lubrication and recommended quantity. In table 2 please see possible radial loads and axial loads on the gearbox.

I Il riduttore **602A** viene fornito completo di olio sintetico per la lubrificazione permanente e non necessita di alcuna manutenzione. Vedi tab.1 per oli e quantità consigliati. In tab.2 sono presenti i carichi radiali e assiali applicabili al riduttore.

D Das Getriebe **602A** ist mit synthetischem Öl gefüllt und ist lebensdauergeschmiert. In Tabelle 1 ist die Schmiermenge und das empfohlene Schmiermittel angegeben. In Tabelle 2 sind die zulässigen Radial- und Axialbelastungen des Getriebes aufgeführt.

F Le réducteur **602A** est fourni complet avec de l'huile synthétique pour la lubrification permanente et ne nécessite aucun entretien. Voir tableau 1 concernant les huiles et les quantités conseillées. Les charges radiales et axiales applicables au réducteur sont précisées dans le tableau 2.

E El reductor tamaño **602A** se suministra, lubricado de por vida con aceite sintético y no requieren mantenimiento alguna. Ver tabla 1, para cantidades y aceites recomendados. En la tabla 2, se encuentran las cargas radiales y axiales admitidas por el reductor.

Standard supplied	For these mounting position specify in the order or add oil Per queste posizioni specificare in fase d'ordine o aggiungere olio					
0.55 LT	0.85 LT	1.10 LT	1.20 LT	1.20 LT	1.25 LT	Ask
AGIP Telium VSF 320			SHELL Omala S4 WE 320			

For all details on lubrication and plugs check our website **tab. 1**
Per maggiori dettagli su lubrificazione e tappi olio vedi il nostro sito web

RADIAL AND AXIAL LOADS								
Output shaft Albero di uscita			$F_{eq} = F_r \cdot \frac{60.5}{X+25.5}$					
n ₂	FA	FR	n ₂	FA	FR	n ₂	FA	FR
300	560	2800	140	740	3700	70	890	4200
250	600	3000	120	760	3800	40	1160	5800
200	640	3200	85	840	4000	15	1300	6500
Input shaft Albero di entrata								
n ₁	FA	FR						
1400	450	2250						
900	500	2500						
500	600	3000						

tab. 2

P602A-B1... With feet
Con piedini

Gearbox weight **14.1 kg**
peso riduttore With feet **14.5 kg**

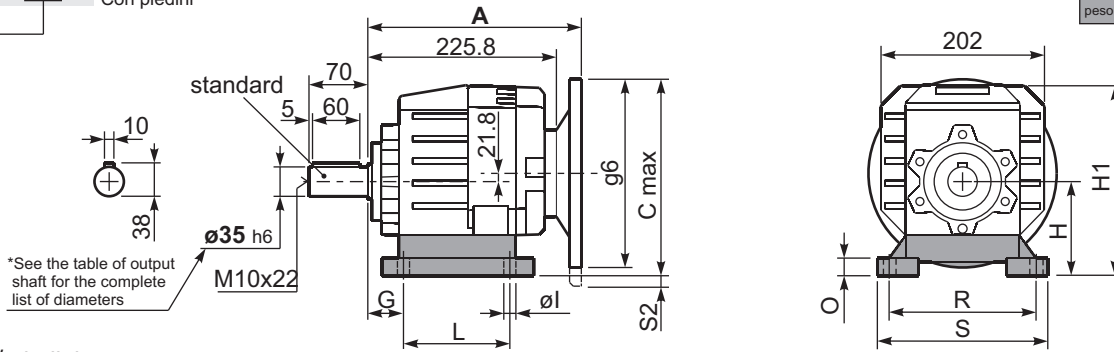

Feet / piedini

Feet Code	Market reference	G	H	R	L	S	H1	O	øl	S2 only with motor flange	B5 max. Flange	kit code
B4	412/3	20	130	180	149.5	216	233	18	14	-	-	KC60.9.024
S4	47-57	30	115	135	165	170	218	24	13.5	13 132B5	-	KC50.9.022
M3	62/3	35	120	170-185	110	230	223	20	14	8 132B5	-	KC60.9.023
S7	77	35	140	170	205	204	243	8	14	-	-	KC60.9.029LM
H4	024-243	35	155	170	150	225	258	30	14	-	-	KC60.9.025
L6	06	19	125	160	106	205	228	8	14	3 132B5	-	KC50.9.026LM
E3	2302/3	19.5	125	170	240	205	228	8	14	-	100/112B5	KC60.9.026LM
P6	162	40	162	160	205	200	265	8	14	-	-	KC60.9.027LM
B5	352/3	23.5	115	170	130	205	218	8	14	13 132B5	-	KC60.9.021LM

Other feet are available, see our web site
Sono disponibili altri piedini, consulta il nostro sito web

A see on page bottom

Most popular types
Tipi più diffusi

P602A-F... Output flanges
flange di uscita

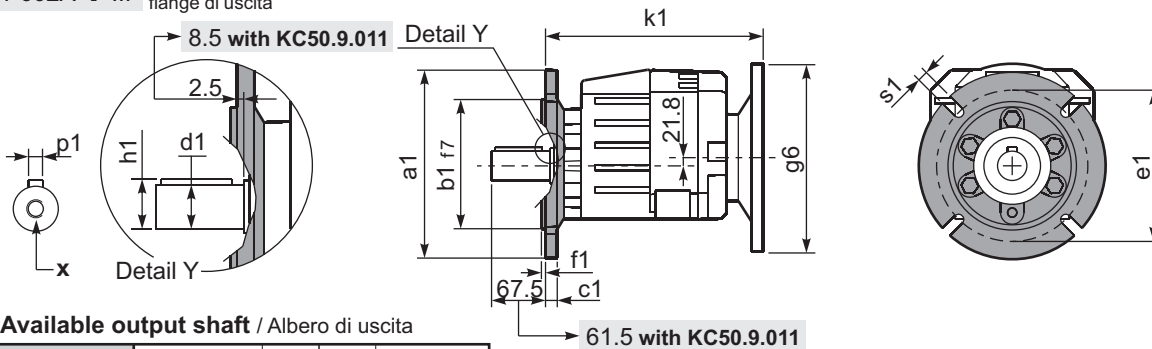

*Available output shaft / Alberi di uscita

	Shaft - d1	p1	h1	x
Standard	ø 35x70	10	38	M10x22
On request A richiesta	ø 28x60	8	31	M8x20
	ø 30x60	8	33	M10x22
	ø 38x70	10	41	M10x25
	ø 40x80	12	43	M12x28

Available output flanges / flange di uscita

a1 ø	b1	c1	e1	f1	s1	kit code
160	110	14	130	3.5	11	KC50.9.011
200	130	13	165	3.5	11	KC50.9.012
250	180	15.5	215	4	14	KC50.9.013

With flange and feet only on request.
Ask for compatibility

P602A-N... Basic gearbox
Riduttore base

R602A-N... Input Shaft
Albero in entrata

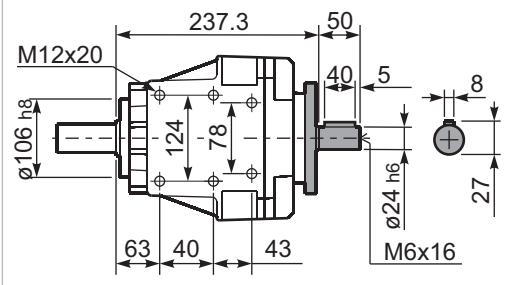
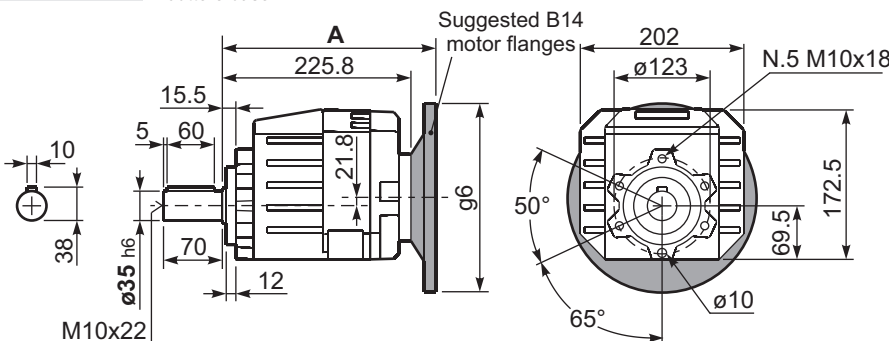

B5 Motor Flanges	A	C _{max}	g6	k1	kit code	k1 with KC50.9.011	B14 Motor Flanges	A	C _{max}	g6	k1	kit code	k1 with KC50.9.011
71 B5	244.3	263.8	160	246.8	KC023.4.041	252.8	80 B14	246.3	243.8	120	248.8	KC085.4.046	254.8
80/90 B5	246.3	283.8	200	248.8	KC023.4.042	254.8	90 B14	246.3	253.8	140	248.8	KC085.4.045	254.8
100/112 B5	255.3	308.8	250	257.8	KC023.4.043	263.8	100/112 B14	255.3	263.8	160	257.8	KC085.4.047	263.8
132 B5	273.3	333.8	300	275.8	KC50.4.043	281.8	132 B14	273.3	283.8	200	275.8	KC50.4.041	281.8



QUICK SELECTION / Selezione veloce

input speed (n₁) = 1400 min⁻¹

Output Speed n ₂ [min ⁻¹]	Ratio i	Motor power P _{1M} [kW]	Output torque M _{2M} [Nm]	Service factor f.s.	Nominal power P _{1R} [kW]	Nominal torque M _{2R} [Nm]	Available B5 motor flanges				Available B14 motor flanges			Output Shaft 	Ratios code
							B	C	D	E	Q	R	T		
							63	71	80	90	71	80	90		
35.2	39.79	1.5	382	1.1	1.7	434	B				C	C		191316	05
29.6	47.22	1.5	453	1.1	1.7	515	B				C	C		191314	06
25.6	54.73	1.5	525	1.0	1.5	515	B				C	C		171314	07
24.5	57.13	1.5	548	0.9	1.4	520	B				C	C		191312	08
21.1	66.22	1.1	464	1.1	1.2	520	B				C	C		171312	09
19.7	71.01	1.1	498	0.9	0.96	435	B				C	C		191310	10
18.3	76.69	1.1	538	1.0	1.0	515	B				C	C		131314	11
17.0	82.30	0.75	396	1.1	0.82	435	B				C	C		171310	12
16.7	83.59	0.75	402	1.1	0.82	440	B				C	C		190814	13
15.1	92.78	0.75	446	1.2	0.87	520	B				C	C		131312	14
13.4	104.68	0.75	503	1.0	0.77	515	B				C	C		101314	15
11.9	117.22	0.75	564	0.9	0.69	520	B				C	C		170812	16
11.1	126.65	0.55	449	1.2	0.64	520	B				C	C		101312	17
10.3	135.74	0.55	482	0.9	0.51	440	B				C	C		130814	18
9.6	145.68	0.37	346	1.3	0.47	435	B				C	C		170810	19
8.9	157.40	0.37	373	1.2	0.43	435	B				C	C		101310	20
8.5	165.29	0.37	392	1.3	0.49	520	B				C	C		91312	21
7.6	185.29	0.37	439	1.0	0.37	440	B				C	C		100814	22
6.8	205.43	0.37	487	0.9	0.33	435	B				C	C		91310	23
6.2	224.18	0.37	532	1.0	0.36	520	B				C	C		100812	24
5.8	241.82	0.25	387	1.1	0.28	440	B				C	C		90814	25
5.0	278.62	0.25	446	1.0	0.24	435	B				C	C		100810	26
4.8	292.57	0.25	468	1.1	0.28	520	B				C	C		90812	27
3.9	363.63	0.18	445	1.0	0.19	435	B				C	C		90810	28

The dynamic efficiency is **0.94** for all ratios

A Motor Flanges Available
Flange Motore Disponibili

B Supplied with Reduction Bushing
Fornito con Bussola di Riduzione

B Available on Request without reduction bushing
Disponibile a Richiesta senza Bussola di Riduzione

C Motor Flange Holes Position
Posizione Fori Flangia Motore

EN Unit **603A** is supplied with synthetic oil for lifetime lubrication, no maintenance is necessary. See table 1 for lubrication and recommended quantity. In table 2 please see possible radial loads and axial loads on the gearbox.

I Il riduttore **603A** viene fornito completo di olio sintetico per la lubrificazione permanente e non necessita di alcuna manutenzione. Vedi tab.1 per oli e quantità consigliati. In tab.2 sono presenti i carichi radiali e assiali applicabili al riduttore.

D Das Getriebe **603A** ist mit synthetischem Öl gefüllt und ist lebensdauergeschmiert. In Tabelle 1 ist die Schmiermenge und das empfohlene Schmiermittel angegeben. In Tabelle 2 sind die zulässigen Radial- und Axialbelastungen des Getriebes aufgeführt.

F Le réducteur **603A** est fourni complet avec de l'huile synthétique pour la lubrification permanente et ne nécessite aucun entretien. Voir tableau 1 concernant les huiles et les quantités conseillées. Les charges radiales et axiales applicables au réducteur sont précisées dans le tableau 2.

E El reductor tamaño **603A** se suministra, lubricado de por vida con aceite sintético y no requieren mantenimiento alguna. Ver tabla 1, para cantidades y aceites recomendados. En la tabla 2, se encuentran las cargas radiales y axiales admitidas por el reductor.

Standard supplied	For these mounting position specify in the order or add oil Per queste posizioni specificare in fase d'ordine o aggiungere olio					
B3	B6	B7	B8	V5	V6	V8
0.75 LT	0.90 LT	1.15 LT	1.25 LT	1.30 LT	1.35 LT	Ask
AGIP Telium VSF 320			SHELL Omala S4 WE 320			

For all details on lubrication and plugs check our website **tab. 1**
Per maggiori dettagli su lubrificazione e tappi olio vedi il nostro sito web

RADIAL AND AXIAL LOADS								
Output shaft Albero di uscita			$F_{eq} = F_R \cdot \frac{60.5}{X+25.5}$					
n ₂	FA	FR	n ₂	FA	FR	n ₂	FA	FR
300	560	2800	140	740	3700	70	890	4200
250	600	3000	120	760	3800	40	1160	5800
200	640	3200	85	840	4000	15	1300	6500
Input shaft Albero in entrata								
n ₁	FA	FR						
1400	400	2000						
900	440	2200						
500	440	2200						

tab. 2

P603A-B1... With feet
Con piedini

Gearbox weight **14.3 kg**
peso riduttore With feet **14.7 Kg**

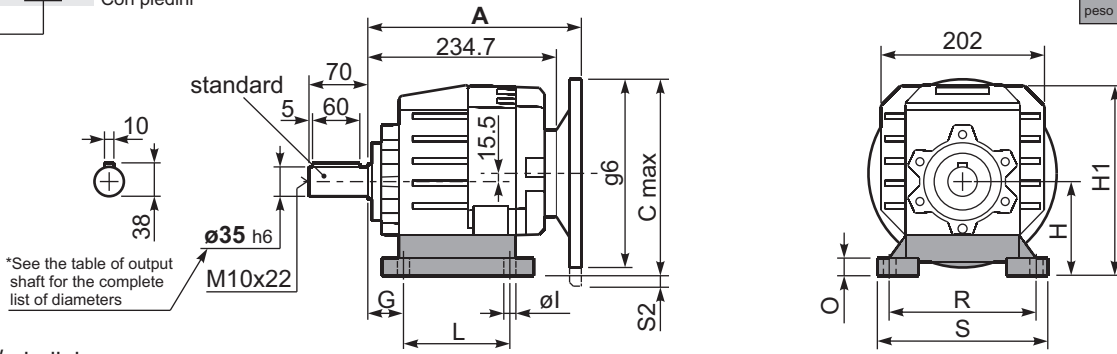

Feet / piedini

Feet Code	Market reference	G	H	R	L	S	H1	O	øl	S2 only with motor flange	B5 max. Flange	kit code
B4	412/3	20	130	180	149.5	216	233	18	14	-	-	KC60.9.024
S4	47-57	30	115	135	165	170	218	24	13.5	-	-	KC50.9.022
M3	62/3	35	120	170-185	110	230	223	20	14	-	-	KC60.9.023
S7	77	35	140	170	205	204	243	8	14	-	-	KC60.9.029LM
H4	024-243	35	155	170	150	225	258	30	14	-	-	KC60.9.025
L6	06	19	125	160	106	205	228	8	14	-	-	KC50.9.026LM
E3	2302/3	19.5	125	170	240	205	228	8	14	-	-	KC60.9.026LM
P6	162	40	162	160	205	200	265	8	14	-	-	KC60.9.027LM
B5	352/3	23.5	115	170	130	205	218	8	14	-	-	KC60.9.021LM

Other feet are available, see our web site
Sono disponibili altri piedini, consulta il nostro sito web

A see on page bottom

Most popular types
Tipi più diffusi

P603A-F... Output flanges
flange di uscita

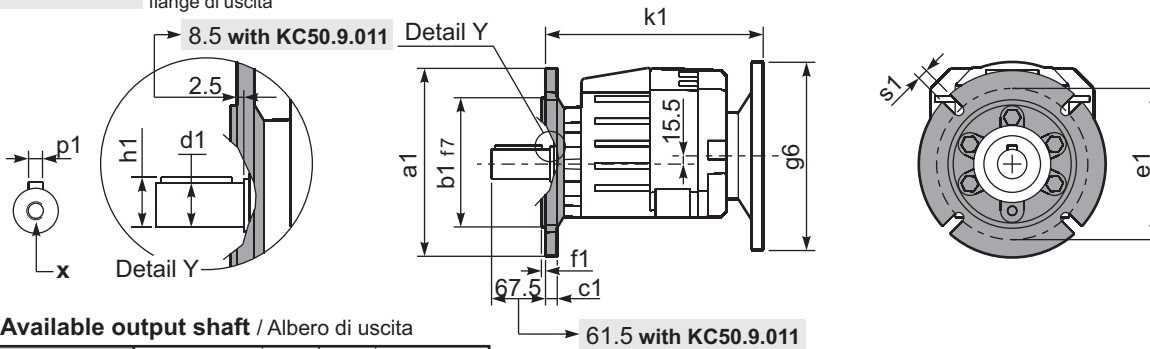

*Available output shaft / Alberi di uscita

	Shaft - d1	p1	h1	x
Standard	ø 35x70	10	38	M10x22
On request A richiesta	ø 28x60	8	31	M8x20
	ø 30x60	8	33	M10x22
	ø 38x70	10	41	M10x25
	ø 40x80	12	43	M12x28

Available output flanges / flange di uscita

a1 ø	b1	c1	e1	f1	s1	kit code
160	110	14	130	3.5	11	KC50.9.011
200	130	13	165	3.5	11	KC50.9.012
250	180	15.5	215	4	14	KC50.9.013

With flange and feet only on request. Ask for compatibility

P603A-N... Basic gearbox
Riduttore base

R603A-N... Input Shaft
Albero in entrata

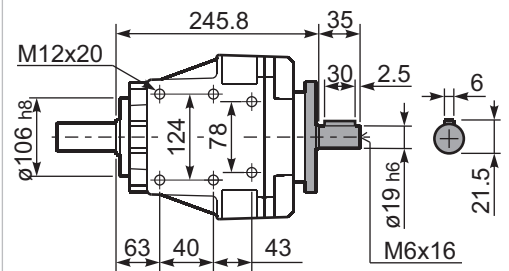
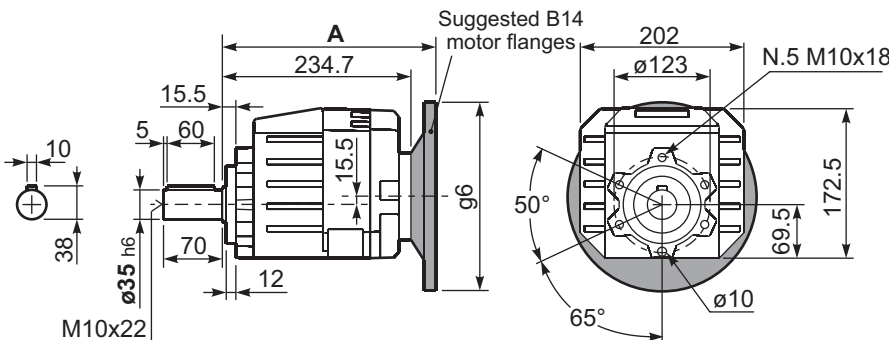

B5 Motor Flanges	A	C _{max}	g6	k1	kit code	k1 with KC50.9.011
63 B5	255.2	247.5	140	257.7	K063.4.041	263.7
71 B5	253.2	257.5	160	255.7	K063.4.042	261.7
80/90 B5	255.2	277.5	200	257.7	K063.4.043	263.7

B14 Motor Flanges	A	C _{max}	g6	k1	kit code	k1 with KC50.9.011
71 B14	253.2	230	105	255.7	K063.4.047	261.7
80 B14	255.2	237.5	120	257.7	K063.4.046	263.7
90 B14	255.2	247.5	140	257.7	K063.4.041	263.7

Cast iron gearboxes

A modular and compact product

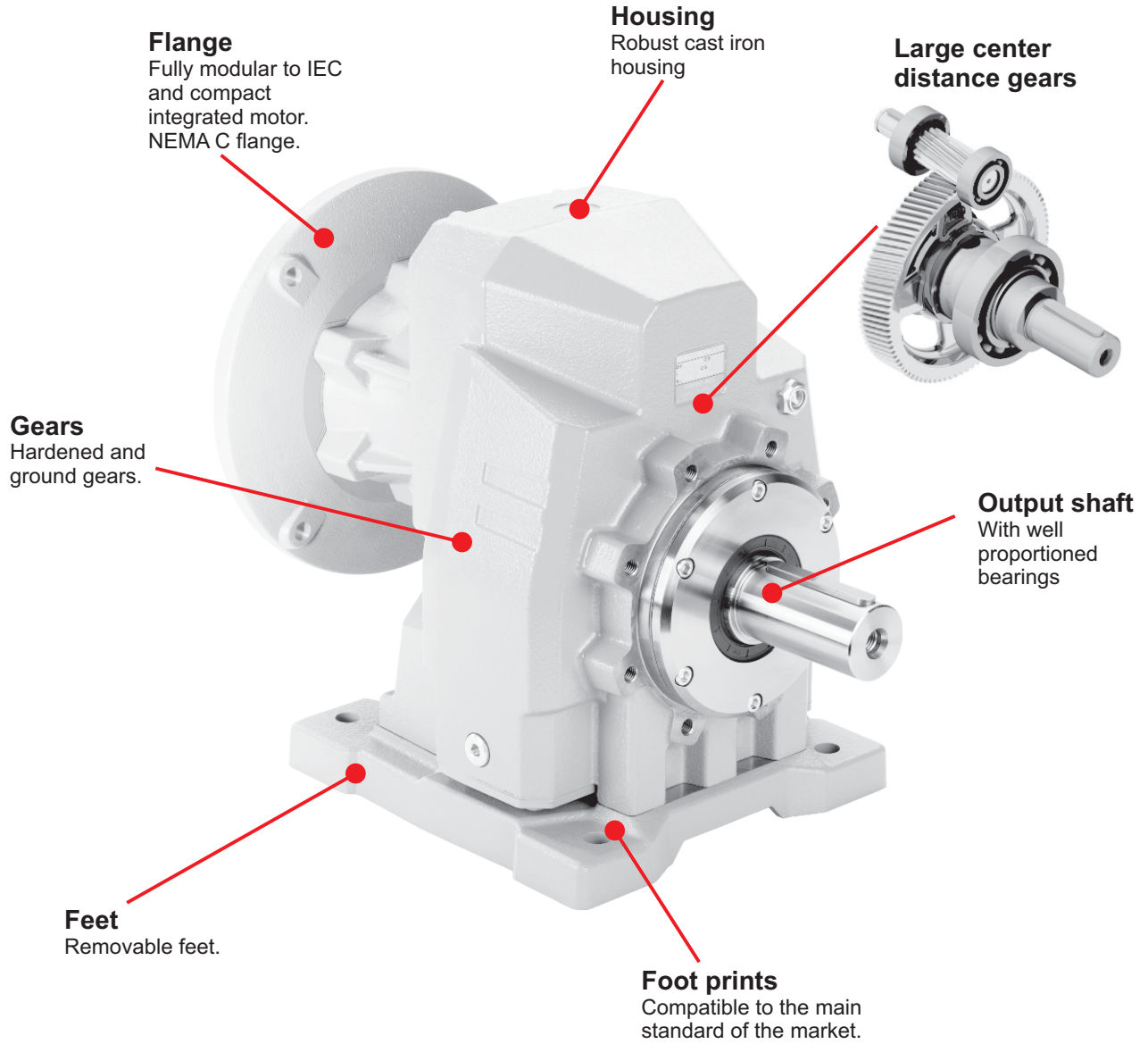

Single-piece Cast Iron housing

with high tensile strength. Precision machined for alignment of bearings and gearing

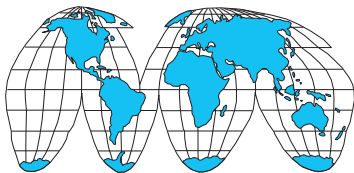
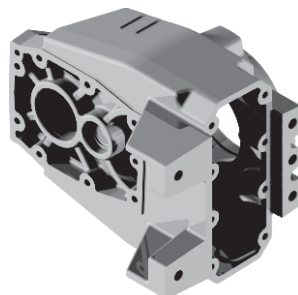

World wide sales network.

Specific type datasheet on page...

On page / A pagina / Auf Seite / À la page / En la página

1 Stage



Types / Tipi
Tipen / Types
Tipos

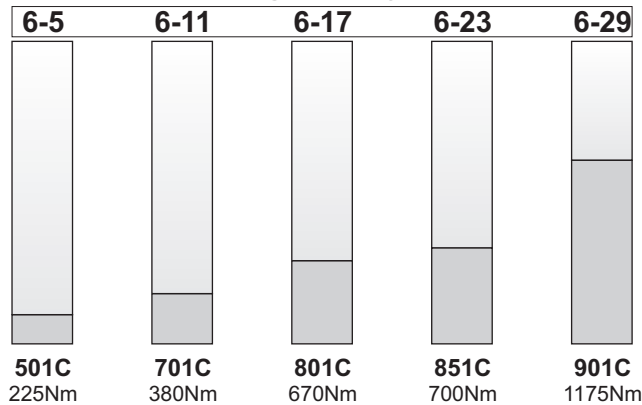

On page / A pagina / Auf Seite / À la page / En la página

2 and 3 Stages

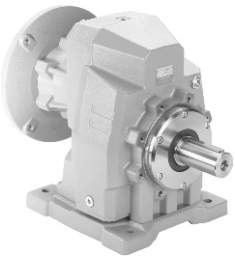

Types / Tipi
Tipen / Types
Tipos

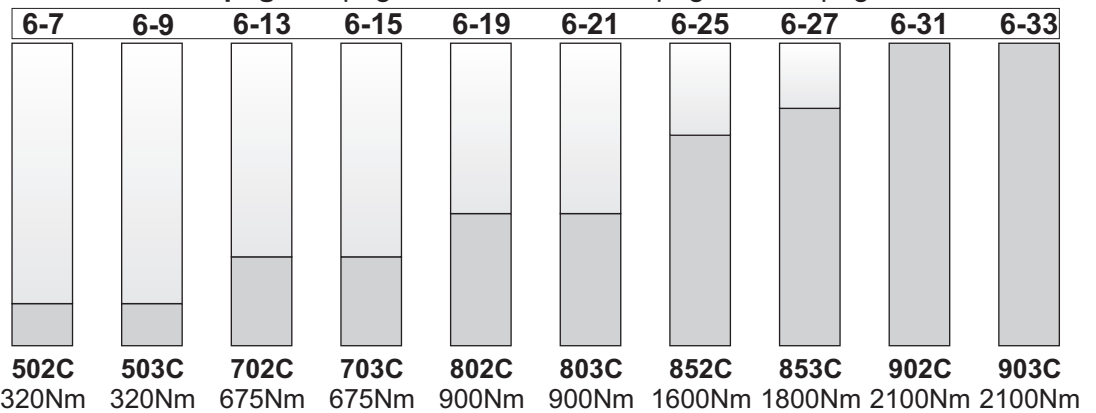

On page / A pagina / Auf Seite / À la page / En la página

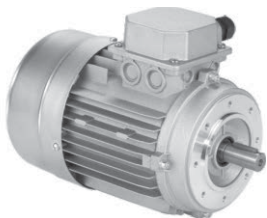

Types / Tipi
Tipen / Types
Tipos

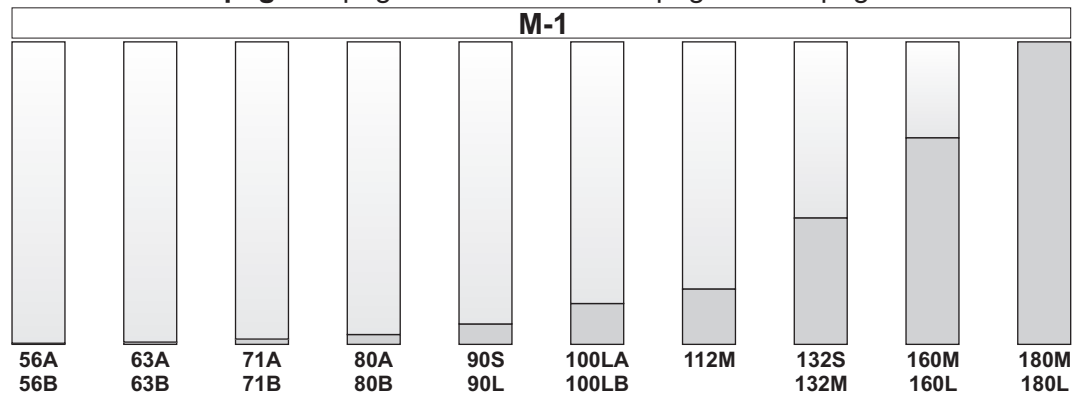

Type - Tipo - Typ
Type - Tipo

Size - Grandezza - Grösse
Taille - Tomafío

Mounting - Montaggio
Montage - Fixation
Tipo de montaje

P

702C

-F

Cast iron coaxial gear boxes
Riduttori coassiali in Ghisa

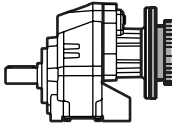

With IEC motor

M

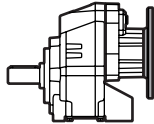

With motor flange

P

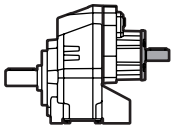

With male input shaft

R

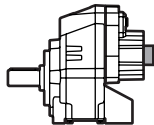

Modular base

B

1 Stage
Riduzione
Stufe
Trains
Etapas

501C
701C
801C
851C
901C

2 Stages
Riduzioni
Stufen
Trains
Etapas

502C
702C
802C
852C
902C

3 Stages
Riduzioni
Stufen
Trains
Etapas

503C
703C
803C
853C
903C

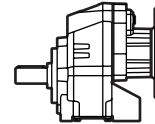

Without flange / feet

-N

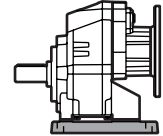

Mounted feet

B..

Feet / piedini

Feet Code	Market reference	G	H	R	L	L1	S
B1	112	18	85	110	87	50	
B2	212/3	18	100	130	107.5		
S1	17	18	75	110	90+20		
S2	27	25	90	110	130		
M1	42/3	25	80	110+120	85		
L4	04	13	80	105			
L5	05	16	100	125			

You see feet code in the chart of the dimensions
Vedi codice piede nella tabella delle dimensioni

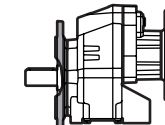

Output flange mounted

-F

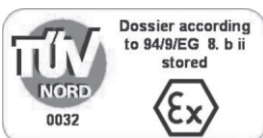

Dossier according to 94/9/EG 8. b ii stored

On request we can deliver our products according to the ATEX
A richiesta possiamo fornire i nostri prodotti secondo le normative ATEX
Auf Anfrage können wir unsere Produkte den Richtlinien ATEX entsprechend liefern
Sur demande nos produits peuvent se conformer à la réglementation ATEX
A pedido, se pueden enviar nuestros productos de acuerdo con las normas ATEX.

Ratio - Rapporto
Untersetzung
Reduction
Relación

Output shaft
Albero uscita
Abtriebswelle
Arbre de sortie
Eje en salida

Output flange
Flangia uscita
Ausgangsflansch
Bride de sortie
Brida en salida

Motor size - Grandezza motore
Motor Grösse
Grandeur moteur - Tamaño motor

Terminal box position
Posizione morsetti
Klemmkastenlage
Position boîte à bornes
Posición caja de bornes

Mounting position
Posizione montaggio
Einbaulage
Position de montage
Posición de montaje

6.57

H

4

-F

B

B3

See technical data table

Vedi tabella dati tecnici.

Technisches Datenblatt beachten

Voir Tableau données techniques

Ver tabla datos técnicos

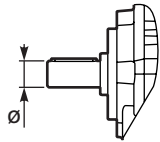

➔ STANDARD

501C 502C
503C

H ➔ **ø30**

I ➔ **ø35**

701C 702C
703C

I ➔ **ø35**

L ➔ **ø38**

M ➔ **ø40**

801C
802C 803C

M ➔ **ø40**

P ➔ **ø50**

851C 852C
853C

P ➔ **ø50**

J ➔ **ø60**

901C 902C
903C

P ➔ **ø50**

J ➔ **ø60**

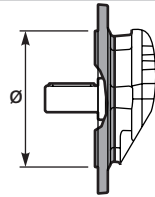

N Senza flangia
Without flange

501C 502C
503C

3 ➔ **ø160**

4 ➔ **ø200**

5 ➔ **ø250**

701C 702C
703C

4 ➔ **ø200**

5 ➔ **ø250**

801C
802C 803C

5 ➔ **ø250**

6 ➔ **ø300**

851C
852C 853C

5 ➔ **ø250**

6 ➔ **ø300**

7 ➔ **ø350**

901C
902C 903C

6 ➔ **ø300**

7 ➔ **ø350**

8 ➔ **ø450**

➔ STANDARD

Standard Flange
Flangia Standard

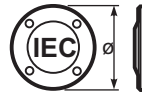

B5

-A=56
(ø120)

-B=63
(ø140)

-C=71
(ø160)

-D=80
(ø200)

-E=90
(ø200)

-F=100+112
(ø250)

-G=132
(ø300)

-H=160
(ø350)

-I=180
(ø350)

B14

-O=56
(ø80)

-P=63
(ø90)

-Q=71
(ø105)

-R=80
(ø120)

-T=90
(ø140)

-U=100+112
(ø160)

-V=132
(ø200)

Type R / Tipo R



503C

-1 ➔ **ø14**

702C 802C
853C 903C

-3 ➔ **ø24**

502C 703C
803C

-2 ➔ **ø19**

852C 902C

-4 ➔ **ø28**

Without flange / Senza flangia



503C

-Z ➔ **ø9**
(56B5)

-0 ➔ **ø11**
(63B5)

-1 ➔ **ø14**
(71B5)

702C 802C
853C 903C

-2 ➔ **ø19**
(80B5)

-3 ➔ **ø24**
(90B5)

-4 ➔ **ø28**
(100B5)

501C

-4 ➔ **ø28**
(100B5)

➔ STANDARD



A



B

STANDARD



C



D

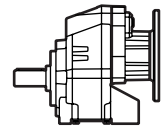

B3

STANDARD

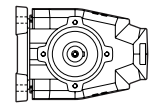

B6

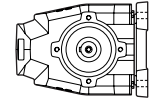

B7

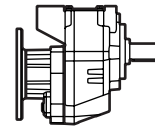

B8

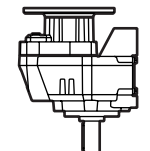

V5

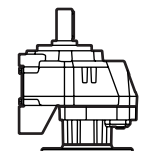

V6

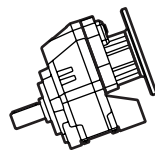

V8

POTENZA RICHIESTA / REQUIRED POWER / ERFORDERLICHE LEISTUNG / PUISSANCE NECESSAIRE / POTENCIA NECESARIA

Lifting / sollevamento / hubantriebe / levage / elevación

$$P [KW] = \frac{M [Kg] \cdot g [9.81] \cdot v [m / s]}{1000}$$

Rotation / rotazione / drehung / rotation / rotação

$$P [KW] = \frac{M [Nm] \cdot n [rpm]}{9550}$$

Linear movement / traslazione / linearbewegung / translation / translación

$$P [KW] = \frac{F [N] \cdot v [m / s]}{1000}$$

TORQUE / COPPIA / DREHMOMENT / COUPLE / PAR

$$M [Nm] = \frac{9550 \cdot P[KW]}{n [rpm]}$$

$$M [lb in] = \frac{63030 \cdot P[HP]}{n [rpm]}$$

RADIAL LOADS / CARICHI RADIALI / RADIALE - UND AXIALLASTEN / CHARGES RADIALES / CARGA RADIAL Y AXIAL

- Radial load generated by external transmissions keyed onto input and/or output shafts.
- Forza radiale generata da organi di trasmissione calettati sugli alberi di ingresso e/o uscita.
- Belastungen der Antriebs- bzw. Abtriebswellen durch von aussen eingebrachte Radiallasten.
- Charge radiale générée par la transmissions calés sur les entrées et / ou des arbres de sortie
- Cargas radiales, generada por transmisiones externas, aplicadas sobre los ejes de entrada y/o salida

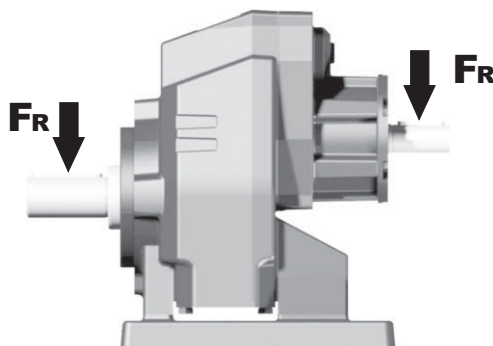

	$F_R [N] = \frac{M [Nm] \cdot 2000}{d [mm]} \cdot f_k$	$F_R [N] = \frac{M [lb in] \cdot 8.9}{d [in]} \cdot f_k$
M	Momento torcente / Output torque / Abtriebsdrehmoment / Couple / Par torsion	
d	Diametro primitivo / Diam. of driving element / Durchmesser der Abtriebseinheit / Diamètre primitif / Diámetro primitivo	
f_k	Coefficiente di trasformazione / Factor / Faktor / Coefficient de transmission / Coeficiente de transmisión 1.15 Ingranaggi / Gearwheels / Zahnrad / Engrenage / Engranaje 1.25 Catena / Chain sprockets / Antriebskette / Chaîne / Cadena 1.75 Cinghia Trapezoidale / Narrow v-belt pulley / Keilriemen / Courroie trap. / Correa trapezoidal 2.50 Cinghia piatta / Flat-belt pulley / Flachzahnriem. / Courroie crantée / Correa plana	

- If your application requires higher radial loads, contact our technical office. Higher load may be possible.
- Nel caso la vostra applicazione richieda carichi radiali superiori consultare il nostro ufficio tecnico, valori maggiori possono essere accettati.
- Wenn Ihre Anwendung höhere Radialbelastungen erfordert, so wenden Sie sich bitte an unser technischen Büro.
- Si votre application demande des charges radiales supérieures, s'adresser à notre bureau technique.
- En el caso en que una aplicación exija una carga radial superior a la especificada en el catálogo, consultar a nuestra oficinas técnica.

How to select a gearbox / Come selezionare un riduttore / Wie wählt man ein Getriebe
Comment sélectionner un réducteur / Cómo seleccionar un reductor

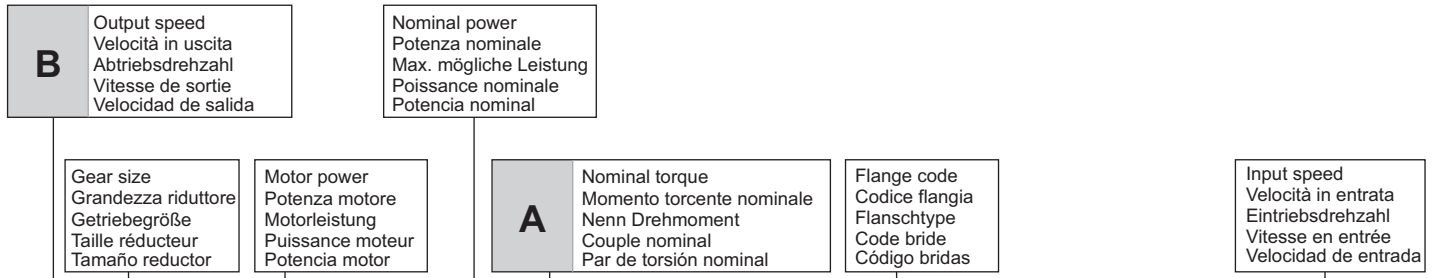

702C Coaxial - Gear **675Nm** Rating - Cast Iron COAXIAL GEARBOXES

QUICK SELECTION / Selezione veloce input speed (n_1) = 1400 min⁻¹

Output Speed n_2 [min ⁻¹]	Ratio i	Motor power P_{1M} [kW]	Output torque M_{2M} [Nm]	Service factor f.s.	Nominal power P_{1R} [kW]	Nominal torque M_{2R} [Nm]	Available B5 motor flanges					Available B14 motor flanges				Output Shaft 	Notes Note	
							C	D	E	F	G	R	T	U	V			Ratio code
213	6.57	7.5	312	1.2	8.8	380	B										3018	01
185	7.56	7.5	359	1.1	7.9	390	B										3016	02
159	8.82	7.5	419	1.0	7.1	410	B										3014	03
113	12.39	7.5	588	1.0	7.2	580	B										2018	04
98	14.24	5.5	499	1.2	6.4	600	B										2016	05



fs

Type of load and starts per hour Tipo di carico e avviamenti per ora		Oper. hours per day Ore di funz. giorn.		
		3 h	10 h	24 h
Continuous or intermittent appl. with start / hour Applicazione cont. o interm. con n.ro operazioni/ora	Uniform / Uniforme	0.8	1	1.25
	Moderate / Moderato	1	1.25	1.5
	Heavy / Forte	1.25	1.5	1.75
Intermittent application with start / hour Applicazione intermittente con n.ro operazioni/ora	Uniform / Uniforme	1	1.25	1.5
	Moderate / Moderato	1.25	1.5	1.75
	Heavy / Forte	1.5	1.75	2.15

D

Motor flange available Flange disponibili Erhältliche Motorflansche Brides disponibles Bridas disponibles	
B) Mounting with reduction ring Montaggio con boccia di riduzione Reduzierhülsen Montage avec douille de réduction Montaje con casquillo de reducción	
C) Motor flangeholes position/terminal box position Posizione fori flangia/basetta motore Bohrungsposition am Motorflansch/-sockel Position trous bride/barrette à bornes moteur Posición agujeros brida / base motor	
B) Available without reduction bushes Disponibile anche senza boccia Auch ohne Reduzierbuchse verfügbar Disponible aussi sans douille de réduction Disponible tambien sin casquillo	

A	Select required torque (according to service factor)	Seleziona la coppia desiderata (comprensiva del fattore di servizio)	Max. Drehmoment in Bezug zum Betriebsfaktor	Sélectionner le couple souhaité (comprenant le facteur de service)	Seleccionar el par deseado (incluyendo el factor de servicio)
B	Select output speed	Seleziona la velocità in uscita	Ausgewählte Abtriebsdrehzahl	Sélectionner la vitesse de sortie	Seleccionar la velocidad de salida
C	On the same line of selected geared motor, you can find the gear ratio	Sulla riga corrispondente alla motorizzazione prescelta si può rilevare il rapporto di riduzione	Auf der gleichen Linie wie die ausgewählte Motorleistung steht auch die Getriebeuntersetzung	Sur la ligne correspondante à la motorisation pré-choisie on peut relever le rapport de réduction	En la línea correspondiente al motor preseleccionado es posible encontrar la relación de reducción
D	Select motor flange available (if requested)	Scegli la flangia disponibile (se richiesta)	Erhältliche Motorflansche (auf Anfrage)	Choisir la bride disponible (si elle est demandée)	Seleccionar la brida disponible (sobre pedido)



QUICK SELECTION / Selezione veloce

input speed (n_1) = 1400 min⁻¹

Output Speed n_2 [min ⁻¹]	Ratio i	Motor power P_{1M} [kW]	Output torque M_{2M} [Nm]	Service factor f.s.	Nominal power P_{1R} [kW]	Nominal torque M_{2R} [Nm]	Available B5 motor flanges			Available B14 motor flanges			Output Shaft 	Ratios code	
							D	E	F	R	T	U			
							80	90	100 112	80	90	100 112			
481	2.91	4	76	1.8	7.2	140	B	B		B	B		3499	standard	01
373	3.75	4	98	1.6	6.4	160	B	B		B	B		28105	ø30	02
263	5.33	4	140	1.2	4.8	170	B	B		B	B		21112		03
219	6.39	4	167	1.0	4.0	170	B	B		B	B		18115	ø35	04
178	7.85	4	205	1.1	4.3	225	B	B		B	B		13102	On request	05

The dynamic efficiency is **0.98** for all ratios

Motor Flanges Available
Flange Motore Disponibili

B) Supplied with Reduction Bushing
Fornito con Bussola di Riduzione

B) Available on Request without reduction bushing
Disponibile a Richiesta senza Bussola di Riduzione

C) Motor Flange Holes Position
Posizione Fori Flangia Motore

EN Unit **501C** is supplied with synthetic oil for lifetime lubrication, no maintenance is necessary. See table 1 for lubrication and recommended quantity. In table 2 please see possible radial loads and axial loads on the gearbox.

I Il riduttore **501C** viene fornito completo di olio sintetico per la lubrificazione permanente e non necessita di alcuna manutenzione. Vedi tab.1 per oli e quantità consigliati. In tab.2 sono presenti i carichi radiali e assiali applicabili al riduttore.

D Das Getriebe **501C** ist mit synthetischem Öl gefüllt und ist lebensdauergeschmiert. In Tabelle 1 ist die Schmiermenge und das empfohlene Schmiermittel angegeben. In Tabelle 2 sind die zulässigen Radial- und Axialbelastungen des Getriebes aufgeführt.

F Le réducteur **501C** est fourni complet avec de l'huile synthétique pour la lubrification permanente et ne nécessite aucun entretien. Voir tableau 1 concernant les huiles et les quantités conseillées. Les charges radiales et axiales applicables au réducteur sont précisées dans le tableau 2.

E El reductor tamaño **501C** se suministra, lubricado de por vida con aceite sintético y no requieren mantenimiento alguna. Ver tabla 1, para cantidades y aceites recomendados. En la tabla 2, se encuentran las cargas radiales y axiales admitidas por el reductor.

Standard supplied	For these mounting position specify in the order or add oil Per queste posizioni specificare in fase d'ordine o aggiungere olio					
1.25 LT	0.80 LT	0.80 LT	0.70 LT	1.40 LT	0.80 LT	Ask
AGIP Telium VSF 320			SHELL Omala S4 WE 320			

For all details on lubrication and plugs check our website **tab. 1**
Per maggiori dettagli su lubrificazione e tappi olio vedi il nostro sito web

RADIAL AND AXIAL LOADS

Output shaft Albero di uscita			$F_{eq} = F_R \cdot \frac{56.5}{X+26.5}$		
n_2	FA	FR	n_2	FA	FR
300	500	2500	140	640	3200
250	540	2700	120	680	3400
200	580	2900	85	760	3800
70	820	4100	40	1020	5100
15	1100	5500			

On request reinforced bearings to increase loads.
A richiesta cuscinetti rinforzati per aumentare i carichi.

tab. 2



QUICK SELECTION / Selezione veloce input speed (n_1) = 1400 min⁻¹

Output Speed n_2 [min ⁻¹]	Ratio i	Motor power P_{1M} [kW]	Output torque M_{2M} [Nm]	Service factor $f.s.$	Nominal power P_{1R} [kW]	Nominal torque M_{2R} [Nm]	Available B5 motor flanges					Available B14 motor flanges				Output Shaft \varnothing	Ratios code
							B	C	D	E	F	Q	R	T	U		
							63	71	80	90	100	112	71	80	90		
167	8.38	4	215	1.0	4.1	225	B					C	C			2821	01
139	10.04	3	194	1.2	3.7	240	B					C	C			2818	02
114	12.33	3	238	1.1	3.2	260	B					C	C			2813	03
92	15.16	2.2	215	1.2	2.6	260	B					C	C			1921	04
80	17.57	2.2	250	1.1	2.3	270	B					C	C			1721	05
77	18.16	2.2	258	1.1	2.4	290	B					C	C			1918	06
67	21.05	2.2	299	1.1	2.3	320	B					C	C			1718	07
63	22.30	2.2	317	1.0	2.2	320	B					C	C			1913	08
57	24.70	2.2	351	0.9	2.0	320	B					C	C			1518	09
54	25.85	2.2	367	0.9	1.9	320	B					C	C			1713	10
47.5	29.49	1.5	289	1.1	1.7	320	B					C	C			1318	11
46.1	30.34	1.5	297	1.1	1.6	320	B					C	C			1513	12
41.7	33.60	1.1	240	1.0	1.1	250	B					C	C			1021	13
38.7	36.21	1.1	259	1.2	1.3	320	B					C	C			1313	14
34.8	40.25	1.1	288	1.0	1.1	300	B					C	C			1018	15
28.3	49.43	1.1	354	0.9	0.99	320	B					C	C			1013	16
26.7	52.53	0.75	258	1.0	0.76	260	B					C	C			918	17
21.7	64.51	0.75	317	1.0	0.75	315	B					C	C			913	18
20.2	69.37	0.37	168	1.1	0.42	190	B					C	C			718	19
16.4	85.19	0.37	206	1.1	0.41	230	B					C	C			713	20

The dynamic efficiency is **0.96** for all ratios

Motor Flanges Available Flange Motore Disponibili
 B) Supplied with Reduction Bushing Fornito con Bussola di Riduzione
 B) Available on Request without reduction bushing Disponibile a Richiesta senza Bussola di Riduzione
 C) Motor Flange Holes Position Posizione Fori Flangia Motore

6

EN Unit **502C** is supplied with synthetic oil for lifetime lubrication, no maintenance is necessary. See table 1 for lubrication and recommended quantity. In table 2 please see possible radial loads and axial loads on the gearbox.

I Il riduttore **502C** viene fornito completo di olio sintetico per la lubrificazione permanente e non necessita di alcuna manutenzione. Vedi tab.1 per oli e quantità consigliati. In tab.2 sono presenti i carichi radiali e assiali applicabili al riduttore.

D Das Getriebe **502C** ist mit synthetischem Öl gefüllt und ist lebensdauer geschmiert. In Tabelle 1 ist die Schmiermenge und das empfohlene Schmiermittel angegeben. In Tabelle 2 sind die zulässigen Radial- und Axialbelastungen des Getriebes aufgeführt.

F Le réducteur **502C** est fourni complet avec de l'huile synthétique pour la lubrification permanente et ne nécessite aucun entretien. Voir tableau 1 concernant les huiles et les quantités conseillées. Les charges radiales et axiales applicables au réducteur sont précisées dans le tableau 2.

E El reductor tamaño **502C** se suministra, lubricado de por vida con aceite sintético y no requieren mantenimiento alguna. Ver tabla 1, para cantidades y aceites recomendados. En la tabla 2, se encuentran las cargas radiales y axiales admitidas por el reductor.

Standard supplied	For these mounting position specify in the order or add oil					
	Per queste posizioni specificare in fase d'ordine o aggiungere olio					
1.25 LT	0.80 LT	0.80 LT	0.70 LT	1.40 LT	0.80 LT	Ask
AGIP Telium VSF 320			SHELL Omala S4 WE 320			

For all details on lubrication and plugs check our website tab. 1
Per maggiori dettagli su lubrificazione e tappi olio vedi il nostro sito web

RADIAL AND AXIAL LOADS

Output shaft
Albero di uscita

$F_R (N)$
 $F_A (N)$

$F_{eq} = F_R \cdot \frac{56.5}{X+26.5}$

$F_{eq} (N)$

n_2	F_A	F_R	n_2	F_A	F_R	n_2	F_A	F_R
300	500	2500	140	640	3200	70	820	4100
250	540	2700	120	680	3400	40	1020	5100
200	580	2900	85	760	3800	15	1100	5500

On request reinforced bearings to increase loads.
A richiesta cuscinetti rinforzati per aumentare i carichi.

Input shaft
Albero in entrata

$F_R (N)$
 $F_A (N)$

n_1	F_A	F_R
1400	240	1200
900	280	1400
500	340	1700

tab. 2

P502C-S4... With feet
Con piedini

Gearbox weight With flange **15.0 kg**
peso riduttore With feet **17.0 kg**

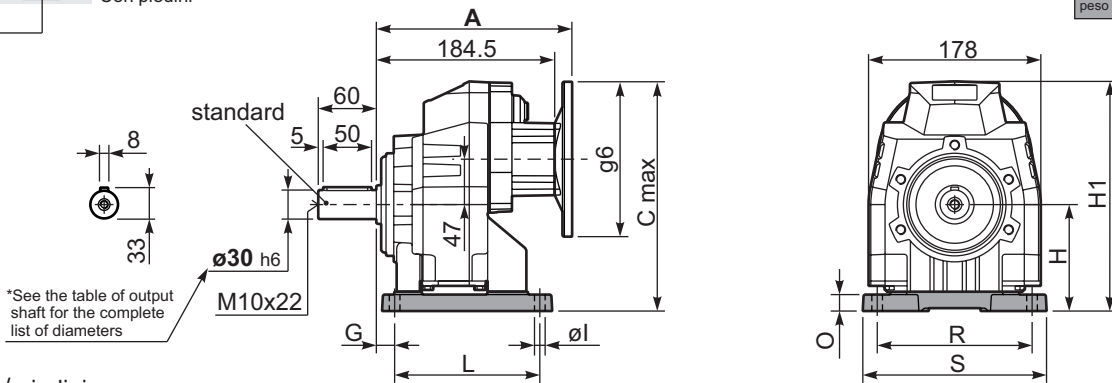

Feet / piedini

Feet Code	Market reference	G	H	R	L	S	H1	O	øl	B5 max. Flange	kit code
B3	312/3	18	110	160	130	190	237	17	11	-	C50C.9.022
S4	47	30	115	135	165	170	242	22	13.5	-	C50C.9.024
-	-	-	-	-	-	-	-	-	-	-	-
-	-	-	-	-	-	-	-	-	-	-	-
-	-	-	-	-	-	-	-	-	-	-	-

P502C-F... Output flanges
flange di uscita

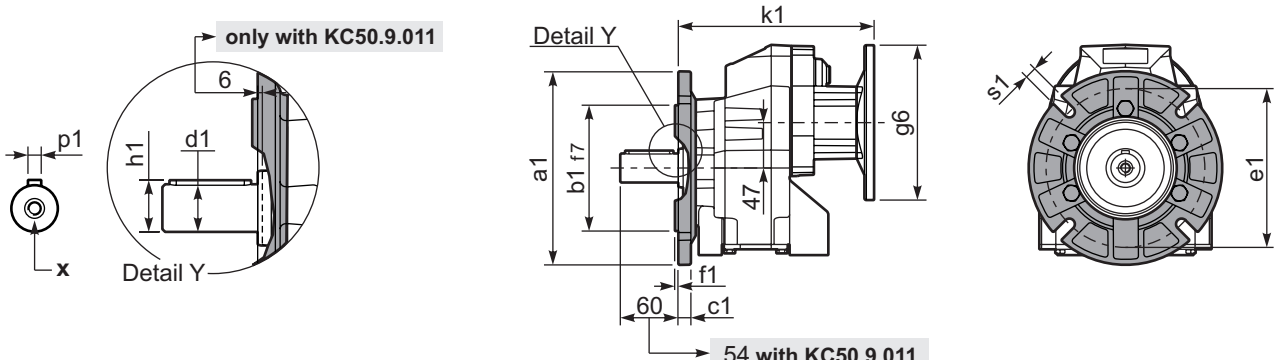

***Available output shaft / Albero di uscita**

	Shaft - d1	p1	h1	x
Standard	ø 30x60	8	33	M10x22
On request A richiesta	ø 35x70	10	38	M10x22
	-	-	-	-

Available output flanges / flange di uscita

a1 ø	b1	c1	e1	f1	s1	kit code
160	110	14	130	3.5	11	KC50.9.011
200	130	13	165	3.5	11	KC50.9.012
250	180	15.5	215	4	14	KC50.9.013

With flange and feet only on request. Ask for compatibility

P502C-N... Basic gearbox
Riduttore base

R502C-N... Input Shaft
Albero in entrata

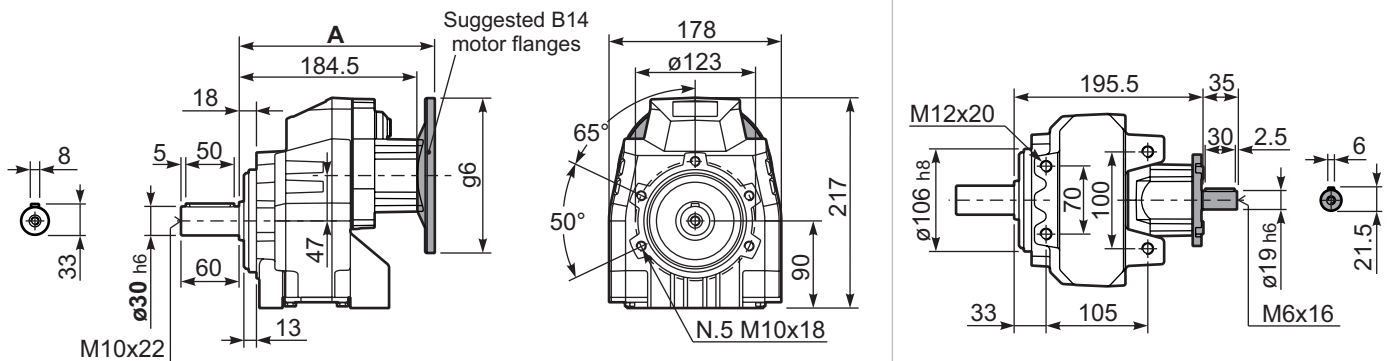

B5 Motor Flanges	A	C _{max}	g6	k1	kit code	k1 with KC50.9.011
63 B5	205	232	140	205	K063.4.041	211
71 B5	203	242	160	203	K063.4.042	209
80/90 B5	205	262	200	205	K063.4.043	211
100/112 B5	220.3	287	250	220.3	KC40.4.043	226.3

B14 Motor Flanges	A	C _{max}	g6	k1	kit code	k1 with KC50.9.011
71 B14	203	214.5	105	203	K063.4.047	209
80 B14	205	222	120	205	K063.4.046	211
90 B14	205	232	140	205	K063.4.041	211
100/112 B14	220.3	242	160	220.3	KC40.4.041	226.3



QUICK SELECTION / Selezione veloce							input speed (n ₁) = 1400 min ⁻¹						
Output Speed n ₂ [min ⁻¹]	Ratio i	Motor power P _{1M} [kW]	Output torque M _{2M} [Nm]	Service factor f.s.	Nominal power P _{1R} [kW]	Nominal torque M _{2R} [Nm]	Available B5 motor flanges		Available B14 motor flanges			Output Shaft \varnothing	Ratios code
							B	C	O	P	Q		
18.8	74.33	0.37	176	1.8	0.67	320			C	C		191313	01
17.0	82.56	0.37	196	1.6	0.60	320			C	C		151318	02
16.0	87.48	0.37	207	1.5	0.57	320			C	C		131713	03
13.8	101.40	0.37	240	1.3	0.49	320			C	C		151313	04
11.4	122.57	0.37	291	1.1	0.41	320			C	C		131313	05
10.1	138.59	0.37	329	1.0	0.36	320			C	C		101318	06
8.7	160.82	0.25	257	1.2	0.31	320			C	C		91713	07
8.2	170.20	0.25	272	1.2	0.29	320			C	C		101313	08
7.6	183.48	0.25	294	1.1	0.27	320			C	C		91318	09
6.5	214.15	0.18	262	1.2	0.23	320			C	C		71713	10
6.2	225.33	0.18	276	1.2	0.22	320			C	C		91313	11
5.7	244.32	0.18	299	1.1	0.20	320			C	C		71318	12
5.5	254.15	0.18	311	1.0	0.20	320			C	C		61713	13
4.8	289.96	0.18	355	0.9	0.17	320			C	C		61318	14
4.7	300.05	0.18	367	0.9	0.17	320			C	C		71313	15
3.9	356.09	0.12	282	1.1	0.14	320			C	C		61313	16

The dynamic efficiency is **0.94** for all ratios

Motor Flanges Available Flange Motore Disponibili
 B) Supplied with Reduction Bushing Fornito con Bussola di Riduzione
 B) Available on Request without reduction bushing Disponibile a Richiesta senza Bussola di Riduzione
 C) Motor Flange Holes Position Posizione Fori Flangia Motore

EN Unit **503C** is supplied with synthetic oil for lifetime lubrication, no maintenance is necessary. See table 1 for lubrication and recommended quantity. In table 2 please see possible radial loads and axial loads on the gearbox.

I Il riduttore **503C** viene fornito completo di olio sintetico per la lubrificazione permanente e non necessita di alcuna manutenzione. Vedi tab.1 per oli e quantità consigliati. In tab.2 sono presenti i carichi radiali e assiali applicabili al riduttore.

D Das Getriebe **503C** ist mit synthetischem Öl gefüllt und ist lebensdauergeschmiert. In Tabelle 1 ist die Schmiermenge und das empfohlene Schmiermittel angegeben. In Tabelle 2 sind die zulässigen Radial- und Axialbelastungen des Getriebes aufgeführt.

F Le réducteur **503C** est fourni complet avec de l'huile synthétique pour la lubrification permanente et ne nécessite aucun entretien. Voir tableau 1 concernant les huiles et les quantités conseillées. Les charges radiales et axiales applicables au réducteur sont précisées dans le tableau 2.

E El reductor tamaño **503C** se suministra, lubricado de por vida con aceite sintético y no requieren mantenimiento alguna. Ver tabla 1, para cantidades y aceites recomendados. En la tabla 2, se encuentran las cargas radiales y axiales admitidas por el reductor.

Standard supplied	For these mounting position specify in the order or add oil Per queste posizioni specificare in fase d'ordine o aggiungere olio					
1.35 LT	0.80 LT	0.80 LT	0.70 LT	1.50 LT	0.85 LT	Ask
AGIP Telium VSF 320			SHELL Omala S4 WE 320			

For all details on lubrication and plugs check our website [tab. 1](#)
Per maggiori dettagli su lubrificazione e tappi olio vedi il nostro sito web

RADIAL AND AXIAL LOADS								
Output shaft Albero di uscita			$F_{eq} = F_R \cdot \frac{56.5}{X+26.5}$					
n ₂	FA	FR	n ₂	FA	FR	n ₂	FA	FR
300	500	2500	140	640	3200	70	820	4100
250	540	2700	120	680	3400	40	1020	5100
200	580	2900	85	760	3800	15	1100	5500
On request reinforced bearings to increase loads. A richiesta cuscinetti rinforzati per aumentare i carichi.								
Input shaft Albero in entrata								
n ₁	FA	FR						
1400	140	700						
900	160	800						
500	190	950						

tab. 2



QUICK SELECTION / Selezione veloce

input speed (n_1) = 1400 min⁻¹

Output Speed n_2 [min ⁻¹]	Ratio i	Motor power P_{1M} [kW]	Output torque M_{2M} [Nm]	Service factor f.s.	Nominal power P_{1R} [kW]	Nominal torque M_{2R} [Nm]	Available B5 motor flanges		B14 motor flanges				Output Shaft		
							G								Ratios code
507	2.76	9	166	1.6	14.4	265	132		not available						
395	3.54	9	213	1.3	11.6	275							2485	ø35	02
277	5.06	9	304	1.0	8.6	290							1891		03
241	5.81	7.5	281	1.2	8.5	330							1693	ø38	04
206	6.79	7.5	329	1.2	8.4	380							1495	ø40	05

The dynamic efficiency is **0.98** for all ratios

On request

A) Motor Flanges Available Flange Motore Disponibili **B) Supplied with Reduction Bushing** Fornito con Bussola di Riduzione **B) Available on Request without reduction bushing** Disponibile a Richiesta senza Bussola di Riduzione **C) Motor Flange Holes Position** Posizione Fori Flangia Motore

EN Unit **701C** is supplied with synthetic oil for lifetime lubrication, no maintenance is necessary. See table 1 for lubrication and recommended quantity. In table 2 please see possible radial loads and axial loads on the gearbox.

I Il riduttore **701C** viene fornito completo di olio sintetico per la lubrificazione permanente e non necessita di alcuna manutenzione. Vedi tab.1 per oli e quantità consigliati. In tab.2 sono presenti i carichi radiali e assiali applicabili al riduttore.

D Das Getriebe **701C** ist mit synthetischem Öl gefüllt und ist lebensdauergeschmiert. In Tabelle 1 ist die Schmiermenge und das empfohlene Schmiermittel angegeben. In Tabelle 2 sind die zulässigen Radial- und Axialbelastungen des Getriebes aufgeführt.

F Le réducteur **701C** est fourni complet avec de l'huile synthétique pour la lubrification permanente et ne nécessite aucun entretien. Voir tableau 1 concernant les huiles et les quantités conseillées. Les charges radiales et axiales applicables au réducteur sont précisées dans le tableau 2.

E El reductor tamaño **701C** se suministra, lubricado de por vida con aceite sintético y no requieren mantenimiento alguna. Ver tabla 1, para cantidades y aceites recomendados. En la tabla 2, se encuentran las cargas radiales y axiales admitidas por el reductor.

Standard supplied	For these mounting position specify in the order or add oil Per queste posizioni specificare in fase d'ordine o aggiungere olio					
1.85 LT	1.40 LT	1.40 LT	1.30 LT	2.25 LT	1.60 LT	Ask
AGIP Telium VSF 320			SHELL Omala S4 WE 320			

For all details on lubrication and plugs check our website **tab. 1**
Per maggiori dettagli su lubrificazione e tappi olio vedi il nostro sito web

RADIAL AND AXIAL LOADS

Output shaft
Albero di uscita

F_R (N)
 F_A (N)

$F_{eq} = F_R \cdot \frac{70}{X+35}$
 F_{eq} (N)

n_2	FA	FR	n_2	FA	FR	n_2	FA	FR
300	680	3400	140	960	4800	70	1300	6500
250	760	3800	120	1040	5200	40	1460	7300
200	900	4500	85	1120	5600	15	1800	9000

On request reinforced bearings to increase loads.
A richiesta cuscinetti rinforzati per aumentare i carichi.

tab. 2

P701C**S6**... With feet
Con piedini

Gearbox weight **36.0 kg**
peso riduttore With feet **39.5 kg**

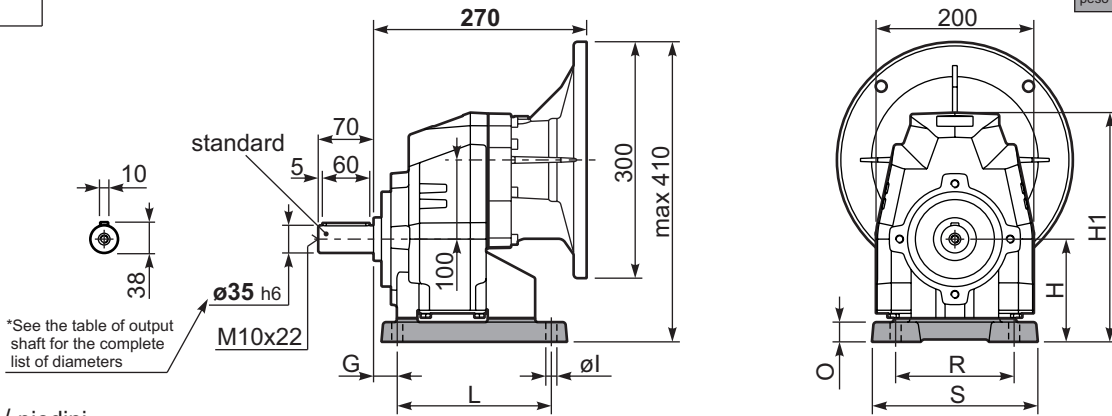

Feet / piedini

Feet Code	Market reference	G	H	R	L	S	H1	O	øl	B5 max. Flange	kit code
B4	412/3	19.5	130	180	149.5	216	290	25	14	-	KC70.9.022
S6	67	30	130	150	195	210	290	25	14	-	KC70.9.024
H5	025/253	35	160	170	175	220	320	30	16	-	KC70.9.023
-	-	-	-	-	-	-	-	-	-	-	-
-	-	-	-	-	-	-	-	-	-	-	-

P701C-**F**... Output flanges
flange di uscita

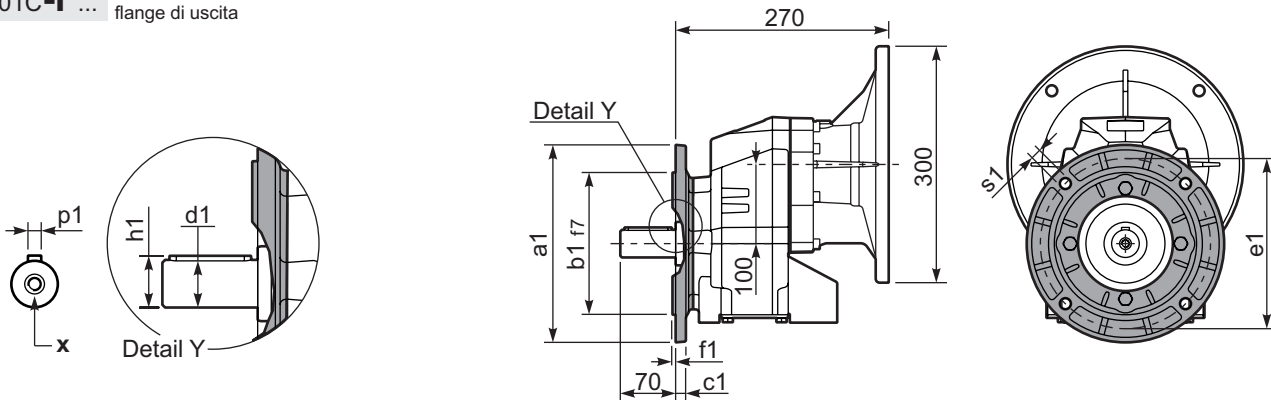

*Available output shaft / Albero di uscita

	Shaft - d1	p1	h1	x
Standard	ø 35x70	10	38	M10x22
On request A richiesta	ø 38x70	10	41	M10x25
	ø 40x80	12	43	M12x28

Available output flanges / flange di uscita

a1 ø	b1	c1	e1	f1	s1	kit code
200	130	11	165	3.5	11	KC70.9.012
250	180	13	215	4	14	KC70.9.013
-	-	-	-	-	-	-

With flange and feet only on request. Ask for compatibility

P701C-**N**... Basic gearbox
Riduttore base

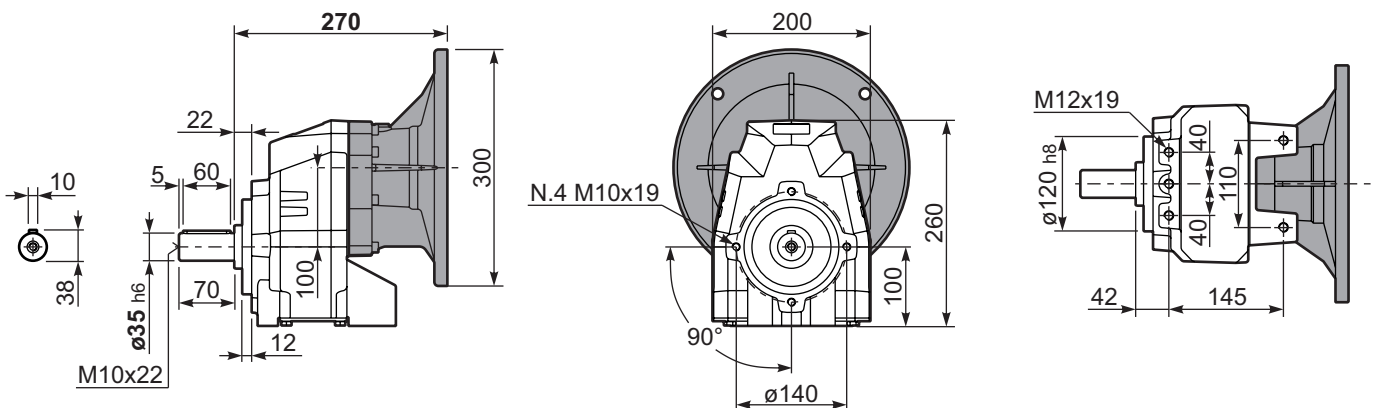



QUICK SELECTION / Selezione veloce

input speed (n_1) = 1400 min⁻¹

Output Speed n_2 [min ⁻¹]	Ratio i	Motor power P_{1M} [kW]	Output torque M_{2M} [Nm]	Service factor $f.s.$	Nominal power P_{1R} [kW]	Nominal torque M_{2R} [Nm]	Available B5 motor flanges					Available B14 motor flanges				Output Shaft 	Ratios code	
							C	D	E	F	G	R	T	U	V			
							71	80	90	100 112	132	80	90	100 112	132			
213	6.57	7.5	312	1.2	8.8	380	B										3018	01
185	7.56	7.5	358	1.1	7.9	390	B										3016	02
159	8.82	7.5	419	1.0	7.1	410	B										3014	03
113	12.39	7.5	588	1.0	7.2	580	B										2018	04
98	14.24	5.5	499	1.2	6.4	600	B										2016	05
84	16.75	5.5	587	1.1	6.1	665	B										1618	06
73	19.25	5.5	675	1.0	5.4	675	B										1616	07
64	21.78	4	558	1.2	4.7	675	B										1318	08
56	25.04	4	642	1.1	4.1	675	B										1316	09
47.9	29.23	4	750	0.9	3.5	675	B										1314	10
45.7	30.65	3	592	1.1	3.4	675	B										1116	11
39.1	35.78	3	691	1.0	2.9	675	B										1114	12
36.3	38.55	2.2	548	1.1	2.3	580	B										818	13
31.6	44.32	2.2	630	1.1	2.3	665	B										816	14
27.1	51.74	2.2	735	0.9	2.0	675	B										814	15
22.9	61.03	1.1	437	1.1	1.2	480	B										616	16
19.6	71.25	1.1	510	1.1	1.2	560	B										614	17

The dynamic efficiency is **0.96** for all ratios

Motor Flanges Available Flange Motore Disponibili
B) Supplied with Reduction Bushing Fornito con Bussola di Riduzione
B) Available on Request without reduction bushing Disponibile a Richiesta senza Bussola di Riduzione
C) Motor Flange Holes Position Posizione Fori Flangia Motore

EN Unit **702C** is supplied with synthetic oil for lifetime lubrication, no maintenance is necessary. See table 1 for lubrication and recommended quantity. In table 2 please see possible radial loads and axial loads on the gearbox.

I Il riduttore **702C** viene fornito completo di olio sintetico per la lubrificazione permanente e non necessita di alcuna manutenzione. Vedi tab.1 per oli e quantità consigliati. In tab.2 sono presenti i carichi radiali e assiali applicabili al riduttore.

D Das Getriebe **702C** ist mit synthetischem Öl gefüllt und ist lebensdauergeschmiert. In Tabelle 1 ist die Schmiermenge und das empfohlene Schmiermittel angegeben. In Tabelle 2 sind die zulässigen Radial- und Axialbelastungen des Getriebes aufgeführt.

F Le réducteur **702C** est fourni complet avec de l'huile synthétique pour la lubrification permanente et ne nécessite aucun entretien. Voir tableau 1 concernant les huiles et les quantités conseillées. Les charges radiales et axiales applicables au réducteur sont précisées dans le tableau 2.

E El reductor tamaño **702C** se suministra, lubricado de por vida con aceite sintético y no requieren mantenimiento alguna. Ver tabla 1, para cantidades y aceites recomendados. En la tabla 2, se encuentran las cargas radiales y axiales admitidas por el reductor.

Standard supplied	For these mounting position specify in the order or add oil Per queste posizioni specificare in fase d'ordine o aggiungere olio					
B3	B6	B7	B8	V5	V6	V8
2.10 LT	1.40 LT	1.40 LT	1.30 LT	2.25 LT	1.60 LT	Ask
AGIP Telium VSF 320			SHELL Omala S4 WE 320			

For all details on lubrication and plugs check our website **tab. 1**
Per maggiori dettagli su lubrificazione e tappi olio vedi il nostro sito web

RADIAL AND AXIAL LOADS

Output shaft
Albero di uscita

$F_R(N)$
 $F_A(N)$

$F_{eq} = F_R \cdot \frac{70}{X+35}$
 $F_{eq}(N)$

n_2	FA	FR	n_2	FA	FR	n_2	FA	FR
300	680	3400	140	960	4800	70	1300	6500
250	760	3800	120	1040	5200	40	1460	7300
200	900	4500	85	1120	5600	15	1800	9000

On request reinforced bearings to increase loads.
A richiesta cuscinetti rinforzati per aumentare i carichi.

Input shaft
Albero in entrata

$F_R(N)$
 $F_A(N)$

n_1	FA	FR
1400	400	2000
900	440	2200
500	440	2200

tab. 2



QUICK SELECTION / Selezione veloce							input speed (n ₁) = 1400 min ⁻¹								
Output Speed n ₂ [min ⁻¹]	Ratio i	Motor power P _{1M} [kW]	Output torque M _{2M} [Nm]	Service factor f.s.	Nominal power P _{1R} [kW]	Nominal torque M _{2R} [Nm]	Available B5 motor flanges				Available B14 motor flanges			Output Shaft	Ratios code
							B	C	D	E	Q	R	T		
							63	71	80	90	71	80	90		
22.6	61.89	1.5	594	1.1	1.7	675	B				C	C		191318	01
19.7	71.16	1.5	683	1.0	1.5	675	B				C	C		191316	02
17.0	82.48	1.5	792	0.9	1.3	675	B				C	C		171316	03
14.5	96.29	1.1	675	1.0	1.1	675	B				C	C		171314	04
13.9	100.51	1.1	705	1.0	1.0	675	B				C	C		131318	05
12.1	115.56	0.75	556	1.2	0.91	675	B				C	C		131316	06
11.1	125.96	0.75	606	1.1	0.82	665	B				C	C		190816	07
10.4	134.91	0.75	649	1.0	0.78	675	B				C	C		131314	08
9.5	147.05	0.75	707	1.0	0.72	675	B				C	C		190814	09
8.2	170.44	0.55	605	1.1	0.62	675	B				C	C		170814	10
7.6	184.15	0.55	653	1.0	0.57	675	B				C	C		101314	11
6.8	205.87	0.55	730	0.9	0.51	675	B				C	C		91316	12
5.8	240.34	0.37	570	1.2	0.44	675	B				C	C		91314	13
5.0	279.22	0.37	662	1.0	0.37	665	B				C	C		100816	14
4.3	325.97	0.37	773	0.9	0.32	675	B				C	C		100814	15
3.8	364.41	0.25	583	1.1	0.28	665	B				C	C		90816	16
3.3	425.43	0.25	681	1.0	0.25	675	B				C	C		90814	17
2.9	481.19	0.18	589	1.1	0.22	665	B				C	C		70816	18
2.5	561.76	0.18	687	1.0	0.19	675	B				C	C		70814	19

The dynamic efficiency is **0.94** for all ratios

Motor Flanges Available
Flange Motore Disponibili

B) Supplied with Reduction Bushing
Fornito con Bussola di Riduzione

B) Available on Request without reduction bushing
Disponibile a Richiesta senza Bussola di Riduzione

C) Motor Flange Holes Position
Posizione Fori Flangia Motore

6

EN Unit 703C is supplied with synthetic oil for lifetime lubrication, no maintenance is necessary. See table 1 for lubrication and recommended quantity. In table 2 please see possible radial loads and axial loads on the gearbox.

I Il riduttore 703C viene fornito completo di olio sintetico per la lubrificazione permanente e non necessita di alcuna manutenzione. Vedi tab.1 per oli e quantità consigliati. In tab.2 sono presenti i carichi radiali e assiali applicabili al riduttore.

D Das Getriebe 703C ist mit synthetischem Öl gefüllt und ist lebensdauergeschmiert. In Tabelle 1 ist die Schmiermenge und das empfohlene Schmiermittel angegeben. In Tabelle 2 sind die zulässigen Radial - und Axialbelastungen des Getriebes aufgeführt.

F Le réducteur 703C est fourni complet avec de l'huile synthétique pour la lubrification permanente et ne nécessite aucun entretien. Voir tableau 1 concernant les huiles et les quantités conseillées. Les charges radiales et axiales applicables au réducteur sont précisées dans le tableau 2.

E El reductor tamaño 703C se suministra, lubricado de por vida con aceite sintético y no requieren mantenimiento alguna. Ver tabla 1, para cantidades y aceites recomendados. En la tabla 2, se encuentran las cargas radiales y axiales admitidas por el reductor.

Standard supplied	For these mounting position specify in the order or add oil					
	Per queste posizioni specificare in fase d'ordine o aggiungere olio					
B3	B6	B7	B8	V5	V6	V8
2.20 LT	1.40 LT	1.40 LT	1.30 LT	2.40 LT	1.70 LT	Ask
AGIP Telium VSF 320			SHELL Omala S4 WE 320			

For all details on lubrication and plugs check our website **tab. 1**
Per maggiori dettagli su lubrificazione e tappi olio vedi il nostro sito web

RADIAL AND AXIAL LOADS

Output shaft
Albero di uscita

$F_R (N)$
 $F_A (N)$

$F_{eq} = F_R \cdot \frac{70}{X+35}$

$F_{eq} (N)$

n ₂	FA	FR	n ₂	FA	FR	n ₂	FA	FR
300	680	3400	140	960	4800	70	1300	6500
250	760	3800	120	1040	5200	40	1460	7300
200	900	4500	85	1120	5600	15	1800	9000

On request reinforced bearings to increase loads.
A richiesta cuscinetti rinforzati per aumentare i carichi.

Input shaft
Albero in entrata

$F_R (N)$
 $F_A (N)$

n ₁	FA	FR
1400	240	1200
900	280	1400
500	310	1700

tab. 2



QUICK SELECTION / Selezione veloce

input speed (n_1) = 1400 min⁻¹

Output Speed n_2 [min ⁻¹]	Ratio i	Motor power P_{1M} [kW]	Output torque M_{2M} [Nm]	Service factor f.s.	Nominal power P_{1R} [kW]	Nominal torque M_{2R} [Nm]	Available B5 motor flanges				B14 motor flanges				Output Shaft		
							G				-				Ratios code		
227	6.17	9	371	1.2	10.9	450					not available				18111	standard	01
198	7.06	9	425	1.4	12.7	600									16113	ø40	02
170	8.21	9	494	1.4	12.2	670									14115	ø50	03
The dynamic efficiency is 0.98 for all ratios											On request						

A) Motor Flanges Available
Flange Motore Disponibili

B) Supplied with Reduction Bushing
Fornito con Bussola di Riduzione

B) Available on Request without reduction bushing
Disponibile a Richiesta senza Bussola di Riduzione

C) Motor Flange Holes Position
Posizione Fori Flangia Motore

EN Unit **801C** is supplied without lubricant and equipped with a breather, level and drain plugs. User can add mineral oil keeping existing plugs. Should the user wish to fill it with synthetic oil, it is recommended to replace the existing plugs with a closed plug.
See table 1 for lubrication and recommended quantity. In table 2 please see possible radial loads and axial loads on the gearbox.

I Il riduttore tipo **801C** è fornito privo di lubrificazione con tappi di sfiato, livello e scarico olio. L'utente può immettere olio minerale mantenendo i tappi esistenti. Se immetterà olio sintetico, dovrà sostituire i tappi esistenti con altri tipo chiuso.
Tab.1 per oli e quantità consigliati.
Tab.2 carichi radiali e assiali applicabili al riduttore.

D Das Getriebe der Baugröße **801C** wird ohne Schmiermittel geliefert. Es ist jedoch mit Einfüllschraube, Überdruckventil und Ablassschraube ausgerüstet. Das benötigte mineralische Öl kann über die Einfüllschraube eingefüllt werden. Sollte synthetisches Öl bevorzugt werden, so ist sind das eingebaute Überdruckventil durch eine geschlossenen Schraube zu ersetzen.
In Tabelle 1 ist die Schmiermenge und das empfohlene Schmiermittel angegeben
In Tabelle 2 sind die zulässigen Radial - und Axialbelastungen des Getriebes aufgeführt.

F Le réducteur de type **801C** est fourni sans lubrification et avec un bouchon de remplissage, de niveau et d'évacuation de l'huile. L'utilisateur peut y verser de l'huile minérale en conservant les bouchons existants. S'il y versera de l'huile synthétique, il devra substituer les bouchons existants avec d'autres bouchons de type fermé.
Voir tableau 1 concernant les huiles et les quantités conseillées.
Voir tableau 2 concernant les charges radiales et axiales applicables au réducteur

E El reductor tamaño **801C** se suministra sin lubricante, provisto de tapones de respiración, nivel y descarga de aceite. El usuario puede utilizar aceite mineral, manteniendo los tapones existentes. Si prefiere utilizar aceite sintético deberá sustituir los tapones existentes por tapones ciegos. La prerreducción se suministra con tapones ciegos, lubricado de por vida con aceite sintético. Ver tabla 1, para cantidades y aceites recomendados. En la tabla 2, se encuentran las cargas radiales y axiales admitidas por el reductor.

B3	B6	B7	B8	V5	V6	V8
3.20 LT	1.90 LT	1.90 LT	1.55 LT	3.20 LT	2.20 LT	Ask
AGIP Blasias 460						

For all details on lubrication and plugs check our website **tab. 1**
Per maggiori dettagli su lubrificazione e tappi olio vedi il nostro sito web

RADIAL AND AXIAL LOADS								
Output shaft Albero di uscita			$F_{eq} = F_R \cdot \frac{80.5}{X+40.5}$					
n_2	FA	FR	n_2	FA	FR	n_2	FA	FR
300	1200	6000	140	1600	8000	70	2200	11000
250	1400	7000	120	1800	9000	40	2600	13000
200	1500	7500	85	2000	10000	15	3000	15000
On request reinforced bearings to increase loads. A richiesta cuscinetti rinforzati per aumentare i carichi.								

tab. 2

P801C**S7** ... With feet
Con piedini

Gearbox weight **45.5 kg**
peso riduttore With feet **49.5 kg**

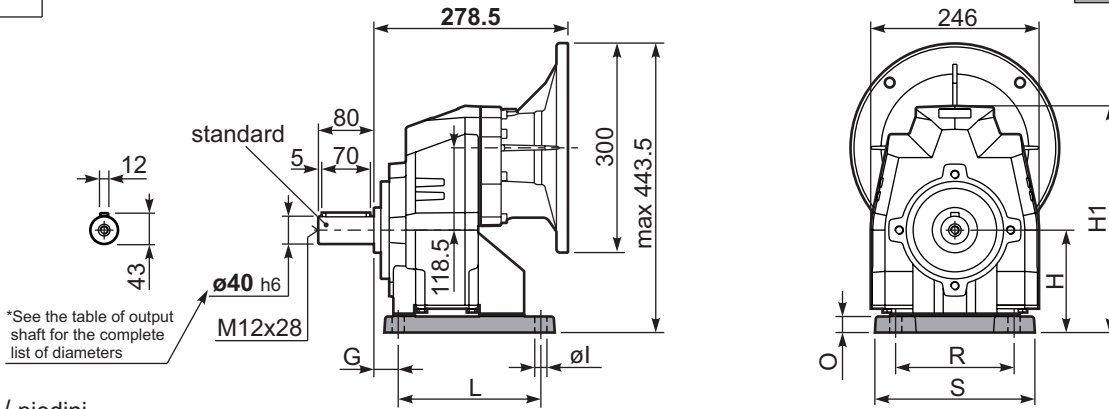

Feet / piedini

Feet Code	Market reference	G	H	R	L	S	H1	O	øI	B5 max. Flange	kit code
B5	512/3	25	155	225	156	270	333.5	30	18	-	KC80.9.022
S7	77	35	140	170	205	230	318.5	18	17.5	-	KC80.9.024
H6	026/263	40	175	215	215	265	353.5	30	16	-	KC80.9.023
-	-	-	-	-	-	-	-	-	-	-	-
-	-	-	-	-	-	-	-	-	-	-	-

P801C-**F** ... Output flanges
flange di uscita

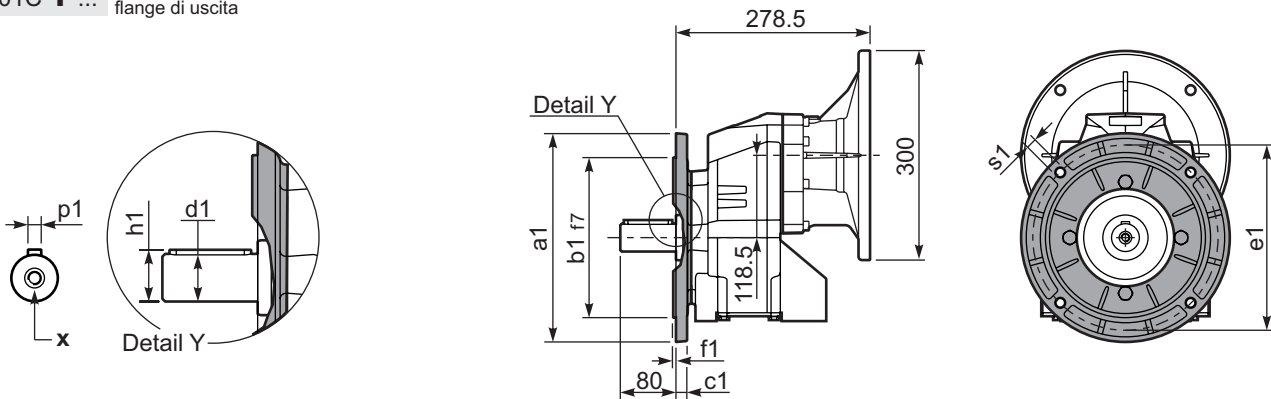

*Available output shaft / Albero di uscita

	Shaft - d1	p1	h1	x
Standard	ø 40x80	12	43	M12x28
On request A richiesta	ø 50x100	14	53.5	M16x36
-	-	-	-	-

Available output flanges / flange di uscita

a1 ø	b1	c1	e1	f1	s1	kit code
250	180	13	215	4	14	KC80.9.013
300	230	16	265	4	14	KC80.9.014
-	-	-	-	-	-	-

With flange and feet only on request. Ask for compatibility

P801C-**N** ... Basic gearbox
Riduttore base

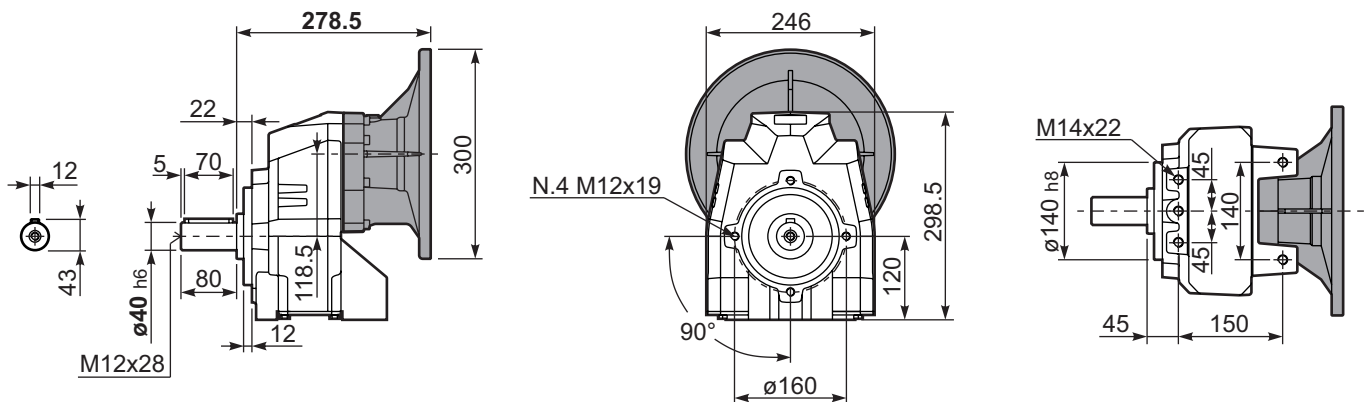



QUICK SELECTION / Selezione veloce

input speed (n₁) = 1400 min⁻¹

Output Speed n ₂ [min ⁻¹]	Ratio i	Motor power P _{1M} [kW]	Output torque M _{2M} [Nm]	Service factor f.s.	Nominal power P _{1R} [kW]	Nominal torque M _{2R} [Nm]	Available B5 motor flanges					Available B14 motor flanges				Output Shaft 	Ratios code	
							C	D	E	F	G	R	T	U	V			
							71	80	90	100 112	132	80	90	100 112	132			
175	8.02	9	473	1.1	9.9	520	B										3018	01
152	9.18	9	541	1.1	9.8	590	B										3016	02
131	10.68	9	630	1.1	9.7	680	B										3014	03
93	15.11	7.5	717	1.1	7.8	775	B										2018	04
81	17.30	7.5	821	1.1	7.8	885	B										2016	05
70	20.13	7.5	955	0.9	6.8	900	B										2014	06
60	23.39	5.5	820	1.1	5.9	900	B										1616	07
51	27.21	5.5	954	0.9	5.1	900	B										1614	08
46.0	30.42	4	780	1.2	4.5	900	B										1316	09
39.6	35.38	4	907	1.0	3.9	900	B										1314	10
37.6	37.24	3	719	1.2	3.7	895	B										1116	11
32.3	43.31	3	836	1.1	3.2	900	B										1114	12
29.8	47.02	2.2	668	1.1	2.3	705	B										818	13
26.0	53.85	2.2	765	1.1	2.3	810	B										816	14
22.4	62.63	2.2	890	1.0	2.2	900	B										814	15
18.9	74.16	1.1	531	1.1	1.2	585	B										616	16
16.2	86.25	1.1	617	1.1	1.2	680	B										614	17

The dynamic efficiency is **0.96** for all ratios

Motor Flanges Available
Flange Motore Disponibili

B) Supplied with Reduction Bushing
Fornito con Bussola di Riduzione

B) Available on Request without reduction bushing
Disponibile a Richiesta senza Bussola di Riduzione

C) Motor Flange Holes Position
Posizione Fori Flangia Motore

EN Unit **802C** is supplied without lubricant and equipped with a breather, level and drain plugs. User can add mineral oil keeping existing plugs. Should the user wish to fill it with synthetic oil, it is recommended to replace the existing plugs with a closed plug.
See table 1 for lubrication and recommended quantity. In table 2 please see possible radial loads and axial loads on the gearbox.

I Il riduttore tipo **802C** è fornito privo di lubrificazione con tappi di sfiato, livello e scarico olio. L'utente può immettere olio minerale mantenendo i tappi esistenti. Se immetterà olio sintetico, dovrà sostituire i tappi esistenti con altri tipo chiuso.
Tab.1 per oli e quantità consigliati.
Tab.2 carichi radiali e assiali applicabili al riduttore.

D Das Getriebe der Baugröße **802C** wird ohne Schmiermittel geliefert. Es ist jedoch mit Einfüllschraube, Überdruckventil und Ablassschraube ausgerüstet. Das benötigte mineralische Öl kann über die Einfüllschraube eingefüllt werden. Sollte synthetisches Öl bevorzugt werden, so ist das eingebaute Überdruckventil durch eine geschlossenen Schraube zu ersetzen.
In Tabelle 1 ist die Schmiermenge und das empfohlene Schmiermittel angegeben
In Tabelle 2 sind die zulässigen Radial - und Axialbelastungen des Getriebes aufgeführt.

F Le réducteur de type **802C** est fourni sans lubrification et avec un bouchon de remplissage, de niveau et d'évacuation de l'huile. L'utilisateur peut y verser de l'huile minérale en conservant les bouchons existants. S'il y versera de l'huile synthétique, il devra substituer les bouchons existants avec d'autres bouchons de type fermé.
Voir tableau 1 concernant les huiles et les quantités conseillées.
Voir tableau 2 concernant les charges radiales et axiales applicables au réducteur

E El reductor tamaño **802C** se suministra sin lubricante, provisto de tapones de respiración, nivel y descarga de aceite. El usuario puede utilizar aceite mineral, manteniendo los tapones existentes. Si prefiere utilizar aceite sintético deberá sustituir los tapones existentes por tapones ciegos. La prerreducción se suministra con tapones ciegos, lubricado de por vida con aceite sintético.
Ver tabla 1, para cantidades y aceites recomendados.
En la tabla 2, se encuentran las cargas radiales y axiales admitidas por el reductor.

B3	B6	B7	B8	V5	V6	V8
3.20 LT	1.90 LT	1.90 LT	1.55 LT	3.20 LT	2.20 LT	Ask

AGIP Blasias 460

For all details on lubrication and plugs check our website **tab. 1**
Per maggiori dettagli su lubrificazione e tappi olio vedi il nostro sito web

RADIAL AND AXIAL LOADS

Output shaft
Albero di uscita

$F_R (N)$
 $F_A (N)$

$F_{eq} = F_R \cdot \frac{80.5}{X+40.5}$

$F_{eq} (N)$

n ₂	FA	FR	n ₂	FA	FR	n ₂	FA	FR
300	1200	6000	140	1600	8000	70	2200	11000
250	1400	7000	120	1800	9000	40	2600	13000
200	1500	7500	85	2000	10000	15	3000	15000

On request reinforced bearings to increase loads.
A richiesta cuscinetti rinforzati per aumentare i carichi.

Input shaft
Albero in entrata

$F_R (N)$
 $F_A (N)$

n ₁	FA	FR
1400	450	2250
900	500	2500
500	600	3000

tab. 2

P802C**S7** ... With feet
Con piedini

Gearbox weight **39.5 kg**
peso riduttore With feet **43.5 kg**

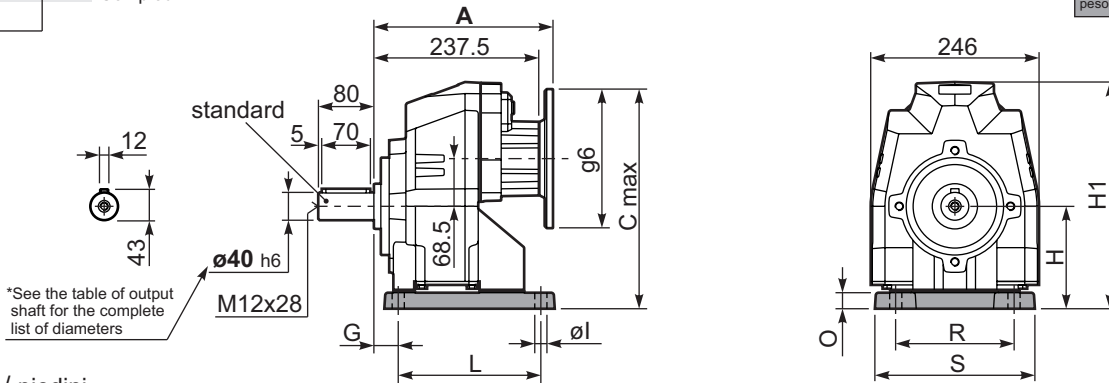

Feet / piedini

Feet Code	Market reference	G	H	R	L	S	H1	O	øl	B5 max. Flange	kit code
B5	512/3	25	155	225	156	270	333.5	30	18	-	KC80.9.022
S7	77	35	140	170	205	230	318.5	18	17.5	-	KC80.9.024
H6	026/263	40	175	215	215	265	353.5	30	16	-	KC80.9.023
-	-	-	-	-	-	-	-	-	-	-	-
-	-	-	-	-	-	-	-	-	-	-	-

P802C-**F** ... Output flanges
flange di uscita

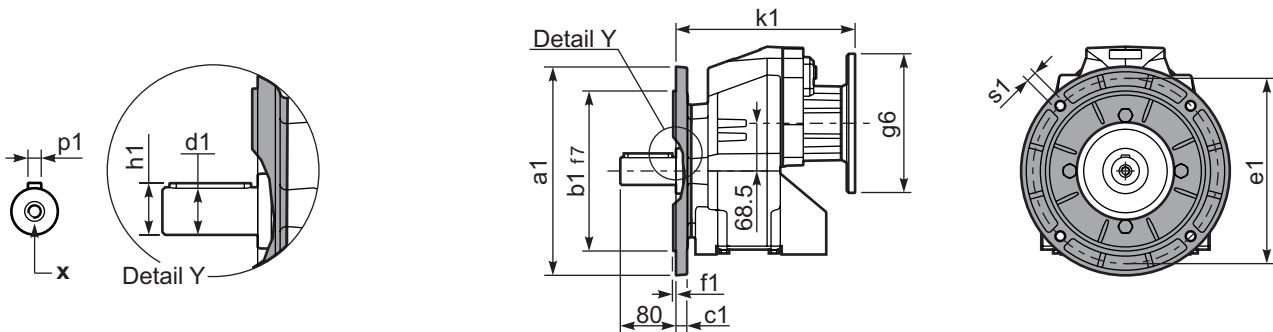

*Available output shaft / Albero di uscita

	Shaft - d1	p1	h1	x
Standard	ø 40x80	12	43	M12x28
On request A richiesta	ø 50x100	14	53.5	M16x36
-	-	-	-	-

Available output flanges / flange di uscita

a1 ø	b1	c1	e1	f1	s1	kit code
250	180	13	215	4	14	KC80.9.013
300	230	16	265	4	14	KC80.9.014
-	-	-	-	-	-	-

With flange and feet only on request. Ask for compatibility

P802C-**N** ... Basic gearbox
Riduttore base

R802C-**N** ... Input Shaft
Albero in entrata

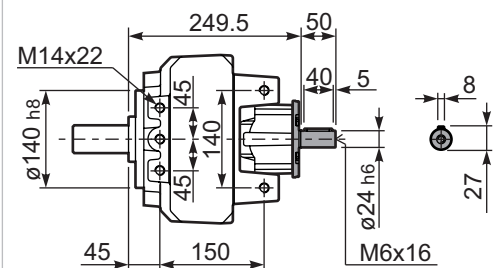
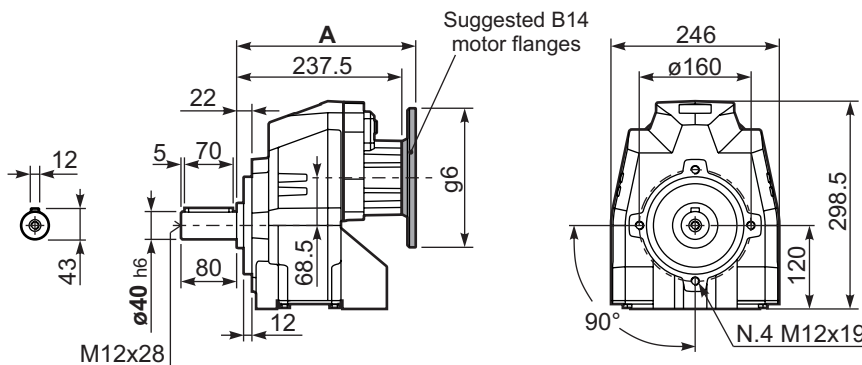

B5 Motor Flanges	A	C _{max}	g6	k1	kit code
71 B5	256	323.5	160	256	KC023.4.041
80/90 B5	258	343.5	200	258	KC023.4.042
100/112 B5	267	368.5	250	267	KC023.4.043
132 B5	285	393.5	300	285	KC50.4.043

B14 Motor Flanges	A	C _{max}	g6	k1	kit code
80 B14	258	303.5	120	258	KC085.4.046
90 B14	258	313.5	140	258	KC085.4.045
100/112 B14	267	323.5	160	267	KC085.4.047
132 B14	285	343.5	200	285	KC50.4.041



QUICK SELECTION / Selezione veloce

input speed (n_1) = 1400 min⁻¹

Output Speed n_2 [min ⁻¹]	Ratio i	Motor power P_{1M} [kW]	Output torque M_{2M} [Nm]	Service factor f.s.	Nominal power P_{1R} [kW]	Nominal torque M_{2R} [Nm]	Available B5 motor flanges				Available B14 motor flanges			Output Shaft \varnothing	Ratios code
							B	C	D	E	Q	R	T		
							63	71	80	90	71	80	90		
18.5	75.50	1.5	725	1.1	1.7	825	B				C	C		191318	01
16.2	86.47	1.5	830	1.1	1.6	900	B				C	C		191316	02
14.0	100.22	1.5	962	0.9	1.4	900	B				C	C		171316	03
12.0	116.56	1.1	817	1.1	1.2	900	B				C	C		171314	04
10.2	136.82	1.1	959	0.9	1.0	900	B				C	C		151314	05
9.1	153.05	0.75	736	1.1	0.83	810	B				C	C		190816	06
8.6	163.31	0.75	785	1.1	0.86	900	B				C	C		131314	07
7.9	178.01	0.75	856	1.1	0.79	900	B				C	C		190814	08
7.3	191.67	0.75	922	1.0	0.73	900	B				C	C		101316	09
6.8	206.32	0.75	992	0.9	0.68	900	B				C	C		170814	10
6.3	222.92	0.55	791	1.1	0.63	900	B				C	C		101314	11
5.8	242.18	0.55	859	1.0	0.58	900	B				C	C		150814	12
5.6	250.15	0.55	888	1.0	0.56	900	B				C	C		91316	13
4.8	289.08	0.55	1026	0.9	0.49	900	B				C	C		130814	14
4.2	330.31	0.37	783	1.1	0.42	890	B				C	C		71316	15
3.5	394.59	0.37	936	1.0	0.36	900	B				C	C		100814	16
2.7	514.99	0.25	824	1.1	0.27	900	B				C	C		90814	17
2.1	680.03	0.18	832	1.1	0.21	900	B				C	C		70814	18

The dynamic efficiency is **0.94** for all ratios

Motor Flanges Available Flange Motore Disponibili B) Supplied with Reduction Bushing Fornito con Bussola di Riduzione B) Available on Request without reduction bushing Disponibile a Richiesta senza Bussola di Riduzione C) Motor Flange Holes Position Posizione Fori Flangia Motore

EN Unit **803C** is supplied without lubricant and equipped with a breather, level and drain plugs. User can add mineral oil keeping existing plugs. Should the user wish to fill it with synthetic oil, it is recommended to replace the existing plugs with a closed plug. See table 1 for lubrication and recommended quantity. In table 2 please see possible radial loads and axial loads on the gearbox.

I Il riduttore tipo **803C** è fornito privo di lubrificazione con tappi di sfiato, livello e scarico olio. L'utente può immettere olio minerale mantenendo i tappi esistenti. Se immetterà olio sintetico, dovrà sostituire i tappi esistenti con altri tipo chiuso. Tab.1 per oli e quantità consigliati. Tab.2 carichi radiali e assiali applicabili al riduttore.

D Das Getriebe der Baugröße **803C** wird ohne Schmiermittel geliefert. Es ist jedoch mit Einfüllschraube, Überdruckventil und Ablassschraube ausgerüstet. Das benötigte mineralische Öl kann über die Einfüllschraube eingefüllt werden. Sollte synthetisches Öl bevorzugt werden, so ist sind das eingebaute Überdruckventil durch eine geschlossenen Schraube zu ersetzen. In Tabelle 1 ist die Schmiermenge und das empfohlene Schmiermittel angegeben. In Tabelle 2 sind die zulässigen Radial - und Axialbelastungen des Getriebes aufgeführt.

F Le réducteur de type **803C** est fourni sans lubrification et avec un bouchon de remplissage, de niveau et d'évacuation de l'huile. L'utilisateur peut y verser de l'huile minérale en conservant les bouchons existants. S'il y versera de l'huile synthétique, il devra substituer les bouchons existants avec d'autres bouchons de type fermé. Voir tableau 1 concernant les huiles et les quantités conseillées. Voir tableau 2 concernant les charges radiales et axiales applicables au réducteur.

E El reductor tamaño **803C** se suministra sin lubricante, provisto de tapones de respiración, nivel y descarga de aceite. El usuario puede utilizar aceite mineral, manteniendo los tapones existentes. Si prefiere utilizar aceite sintético deberá sustituir los tapones existentes por tapones ciegos. La prerreducción se suministra con tapones ciegos, lubricado de por vida con aceite sintético. Ver tabla 1, para cantidades y aceites recomendados. En la tabla 2, se encuentran las cargas radiales y axiales admitidas por el reductor.

B3	B6	B7	B8	V5	V6	V8
3.30 LT	1.90 LT	1.90 LT	1.55 LT	3.40 LT	2.30 LT	Ask

AGIP Blasias 460

For all details on lubrication and plugs check our website [tab. 1](#)
Per maggiori dettagli su lubrificazione e tappi olio vedi il nostro sito web

RADIAL AND AXIAL LOADS

Output shaft
Albero di uscita

F_R (N)
 F_A (N)

$F_{eq} = F_R \cdot \frac{80.5}{X+40.5}$

F_{eq} (N)

n_2	FA	FR	n_2	FA	FR	n_2	FA	FR
300	1200	6000	140	1600	8000	70	2200	11000
250	1400	7000	120	1800	9000	40	2600	13000
200	1500	7500	85	2000	10000	15	3000	15000

On request reinforced bearings to increase loads.
A richiesta cuscinetti rinforzati per aumentare i carichi.

Input shaft
Albero in entrata

F_R (N)
 F_A (N)

n_1	FA	FR
1400	400	2000
900	440	2200
500	440	2200

tab. 2

P803C**S7** ... With feet
Con piedini

Gearbox weight **39.5 kg**
peso riduttore With feet **43.5 kg**

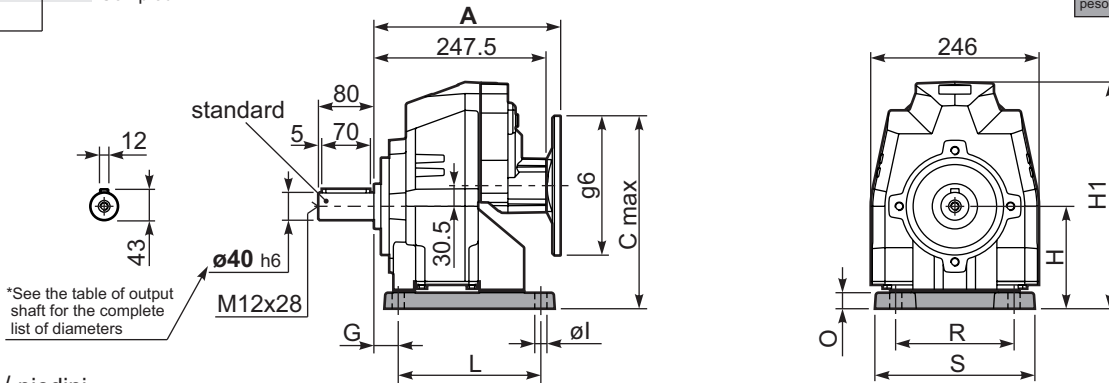

Feet / piedini

Feet Code	Market reference	G	H	R	L	S	H1	O	øI	B5 max. Flange	kit code
B5	512/3	25	155	225	156	270	333.5	30	18	-	KC80.9.022
S7	77	35	140	170	205	230	318.5	18	17.5	-	KC80.9.024
H6	026/263	40	175	215	215	265	353.5	30	16	-	KC80.9.023
-	-	-	-	-	-	-	-	-	-	-	-
-	-	-	-	-	-	-	-	-	-	-	-

P803C-**F** ... Output flanges
flange di uscita

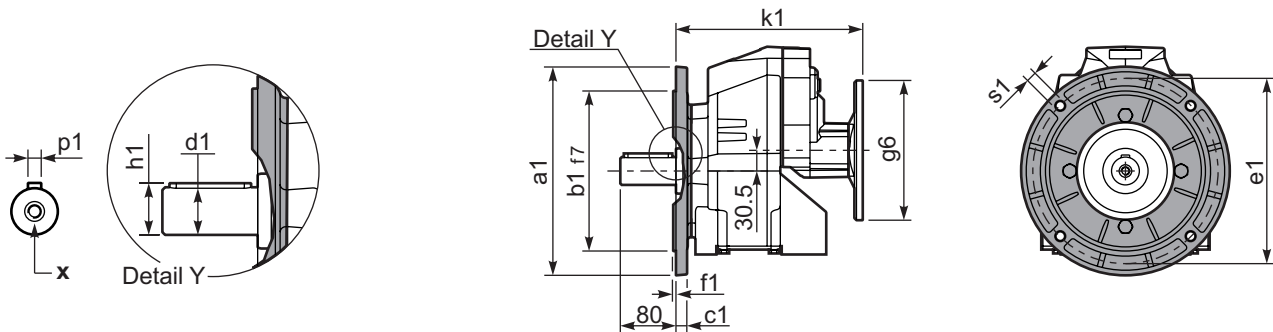

*Available output shaft / Albero di uscita

	Shaft - d1	p1	h1	x
Standard	ø 40x80	12	43	M12x28
On request A richiesta	ø 50x100	14	53.5	M16x36
-	-	-	-	-

Available output flanges / flange di uscita

a1 ø	b1	c1	e1	f1	s1	kit code
250	180	13	215	4	14	KC80.9.013
300	230	16	265	4	14	KC80.9.014
-	-	-	-	-	-	-

With flange and feet only on request. Ask for compatibility

P803C-**N**... Basic gearbox
Riduttore base

R803C-**N**... Input Shaft
Albero in entrata

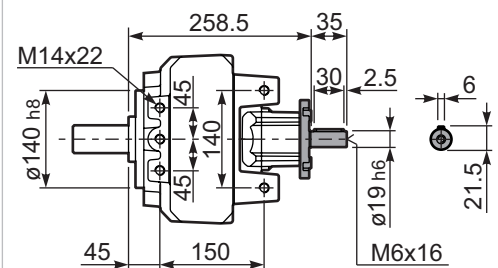
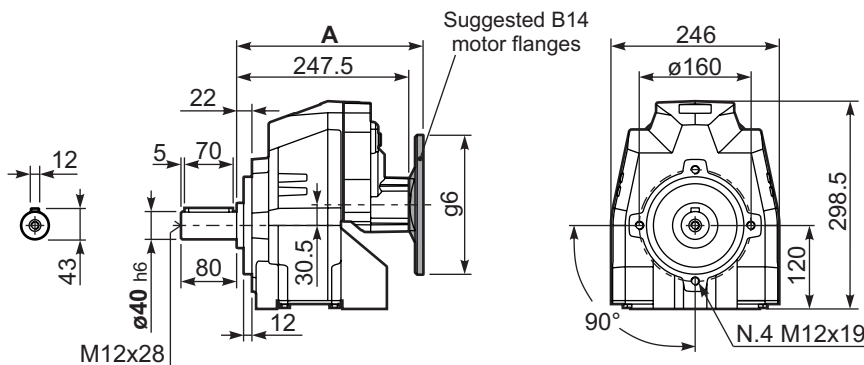

B5 Motor Flanges	A	C _{max}	g6	k1	kit code
63 B5	268	275.5	140	268	K063.4.041
71 B5	266	285.5	160	266	K063.4.042
80/90 B5	268	305.5	200	268	K063.4.043

B14 Motor Flanges	A	C _{max}	g6	k1	kit code
71 B14	266	258	105	266	K063.4.047
80 B14	268	265.5	120	268	K063.4.046
90 B14	268	275.5	140	268	K063.4.041



QUICK SELECTION / Selezione veloce

input speed (n_1) = 1400 min⁻¹

Output Speed n_2 [min ⁻¹]	Ratio i	Motor power P_{1M} [kW]	Output torque M_{2M} [Nm]	Service factor f.s.	Nominal power P_{1R} [kW]	Nominal torque M_{2R} [Nm]	Available B5 motor flanges		B14 motor flanges				Output Shaft 	Ratios code 	
							H	I	-	-	-	-			-
412	3.40	22	480	1.3	26.4	600			not available				1551	standard	01
343	4.08	22	575	1.2	25.7	700			not available				1353	ø50	02
285	4.91	22	693	1.0	21.3	700			not available				1154	ø60	03
The dynamic efficiency is 0.98 for all ratios													On request		

A Motor Flanges Available
Flange Motore Disponibili

B Supplied with Reduction Bushing
Fornito con Bussola di Riduzione

B Available on Request without reduction bushing
Disponibile a Richiesta senza Bussola di Riduzione

C Motor Flange Holes Position
Posizione Fori Flangia Motore

EN Unit **851C** is supplied without lubricant and equipped with a breather, level and drain plugs. User can add mineral oil keeping existing plugs. Should the user wish to fill it with synthetic oil, it is recommended to replace the existing plugs with a closed plug. See table 1 for lubrication and recommended quantity. In table 2 please see possible radial loads and axial loads on the gearbox.

I Il riduttore tipo **851C** è fornito privo di lubrificazione con tappi di sfiato, livello e scarico olio. L'utente può immettere olio minerale mantenendo i tappi esistenti. Se immetterà olio sintetico, dovrà sostituire i tappi esistenti con altri tipo chiuso. Tab.1 per oli e quantità consigliati. Tab.2 carichi radiali e assiali applicabili al riduttore.

D Das Getriebe der Baugröße **851C** wird ohne Schmiermittel geliefert. Es ist jedoch mit Einfüllschraube, Überdruckventil und Ablassschraube ausgerüstet. Das benötigte mineralische Öl kann über die Einfüllschraube eingefüllt werden. Sollte synthetisches Öl bevorzugt werden, so ist sind das eingebaute Überdruckventil durch eine geschlossenen Schraube zu ersetzen. In Tabelle 1 ist die Schmiermenge und das empfohlene Schmiermittel angegeben. In Tabelle 2 sind die zulässigen Radial - und Axialbelastungen des Getriebes aufgeführt.

F Le réducteur de type **851C** est fourni sans lubrification et avec un bouchon de remplissage, de niveau et d'évacuation de l'huile. L'utilisateur peut y verser de l'huile minérale en conservant les bouchons existants. S'il y versera de l'huile synthétique, il devra substituer les bouchons existants avec d'autres bouchons de type fermé. Voir tableau 1 concernant les huiles et les quantités conseillées. Voir tableau 2 concernant les charges radiales et axiales applicables au réducteur

E El reductor tamaño **851C** se suministra sin lubricante, provisto de tapones de respiración, nivel y descarga de aceite. El usuario puede utilizar aceite mineral, manteniendo los tapones existentes. Si prefiere utilizar aceite sintético deberá sustituir los tapones existentes por tapones ciegos. La prerreducción se suministra con tapones ciegos, lubricado de por vida con aceite sintético. Ver tabla 1, para cantidades y aceites recomendados. En la tabla 2, se encuentran las cargas radiales y axiales admitidas por el reductor.

B3	B6	B7	B8	V5	V6	V8
5.30 LT	3.60 LT	3.60 LT	2.80 LT	5.80 LT	4.10 LT	Ask
AGIP Blasias 460						

For all details on lubrication and plugs check our website **tab. 1**
Per maggiori dettagli su lubrificazione e tappi olio vedi il nostro sito web

RADIAL AND AXIAL LOADS

Output shaft
Albero di uscita

F_R (N)
 F_A (N)

$F_{eq} = F_R \cdot \frac{88.5}{X+38.5}$

F_{eq} (N)

n_2	FA	FR	n_2	FA	FR	n_2	FA	FR
300	1800	9000	140	2400	12000	70	3000	15000
250	2000	10000	120	2600	13000	40	3200	16000
200	2200	11000	85	2800	14000	15	4000	20000

On request reinforced bearings to increase loads.
A richiesta cuscinetti rinforzati per aumentare i carichi.

tab. 2

P851C**S8**... With foot
Con piedine

Gearbox weight With flange **90.0 kg**
peso riduttore With feet **80.5 kg**

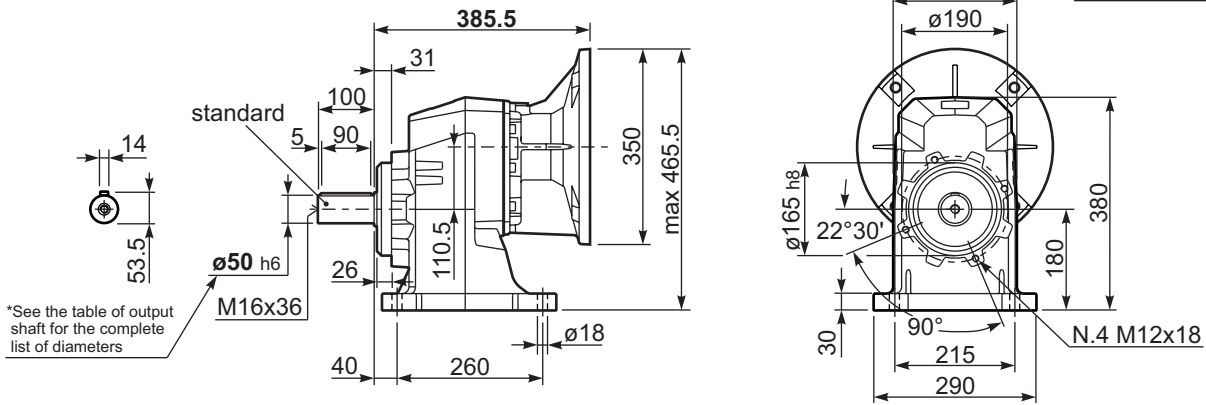

P851C-**F**... Output flanges
flange di uscita

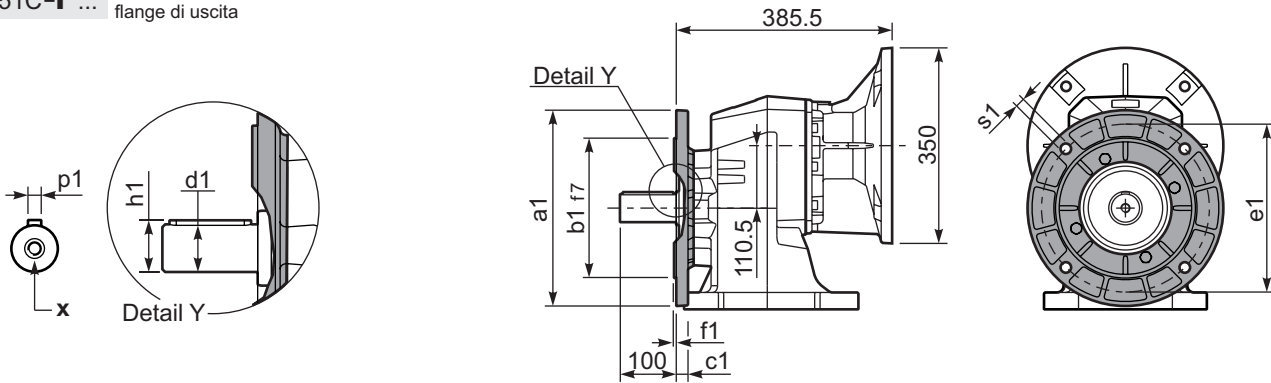

*Available output shaft / Albero di uscita

	Shaft - d1	p1	h1	x
Standard	∅ 50x100	14	53.5	M16x36
On request A richiesta	∅ 60x120	18	64	M20x42
	-	-	-	-

Available output flanges / flange di uscita

a1 ∅	b1	c1	e1	f1	s1	kit code
300	230	21	265	4	14	KC90.9.014
350	250	21	300	5	18	KC90.9.015
-	-	-	-	-	-	-

All flanges are compatible with the foot



QUICK SELECTION / Selezione veloce

input speed (n_1) = 1400 min⁻¹

Output Speed n_2 [min ⁻¹]	Ratio i	Motor power P_{1M} [kW]	Output torque M_{2M} [Nm]	Service factor $f.s.$	Nominal power P_{1R} [kW]	Nominal torque M_{2R} [Nm]	B5 motor flanges				B14 motor flanges				Output Shaft 	Ratios code
							-F	-G	-H	-I	-	-	-	-		
							100 112	132	160	180	-	-	-	-		
317	4.42	22	611	1.1	24.2	700	B							3015	01	
264	5.30	22	733	1.0	20.2	700	B							3013	02	
219	6.38	18.5	742	1.1	19.1	800	B							3011	03	
168	8.33	15	784	1.0	14.7	800	B							2015	04	
140	9.99	15	940	1.0	13.8	900	B							2013	05	
124	11.26	15	1060	1.0	14.9	1100	B							1615	06	
116	12.03	15	1132	1.1	15.2	1200	B							2011	07	
104	13.50	15	1271	1.1	15.8	1400	B							1613	08	
96	14.65	15	1378	1.1	15.6	1500	B							1315	09	
86	16.26	15	1531	1.0	14.1	1500	B							1611	10	
80	17.56	11	1214	1.2	13.0	1500	B							1313	11	
65	21.50	11	1486	1.1	11.4	1600	B							1113	12	
54	25.88	9	1526	1.0	9.4	1600	B							1111	13	
45.0	31.09	7.5	1475	1.0	7.2	1460	B							813	14	
37.4	37.43	5.5	1312	1.2	6.5	1600	B							811	15	

The dynamic efficiency is **0.96** for all ratios

Motor Flanges Available
Flange Motore Disponibili

B) Supplied with Reduction Bushing
Fornito con Bussola di Riduzione

B) Available on Request without reduction bushing
Disponibile a Richiesta senza Bussola di Riduzione

C) Motor Flange Holes Position
Posizione Fori Flangia Motore

EN Unit **852C** is supplied without lubricant and equipped with a breather, level and drain plugs. User can add mineral oil keeping existing plugs. Should the user wish to fill it with synthetic oil, it is recommended to replace the existing plugs with a closed plug.
See table 1 for lubrication and recommended quantity.
In table 2 please see possible radial loads and axial loads on the gearbox.

I Il riduttore tipo **852C** è fornito privo di lubrificazione con tappi di sfiato, livello e scarico olio. L'utente può immettere olio minerale mantenendo i tappi esistenti. Se immetterà olio sintetico, dovrà sostituire i tappi esistenti con altri tipo chiuso.
Tab.1 per oli e quantità consigliati.
Tab.2 carichi radiali e assiali applicabili al riduttore.

D Das Getriebe der Baugröße **852C** wird ohne Schmiermittel geliefert. Es ist jedoch mit Einfüllschraube, Überdruckventil und Ablassschraube ausgerüstet. Das benötigte mineralische Öl kann über die Einfüllschraube eingefüllt werden. Sollte synthetisches Öl bevorzugt werden, so ist sind das eingebaute Überdruckventil durch eine geschlossenen Schraube zu ersetzen.
In Tabelle 1 ist die Schmiermenge und das empfohlene Schmiermittel angegeben
In Tabelle 2 sind die zulässigen Radial - und Axialbelastungen des Getriebes aufgeführt.

F Le réducteur de type **852C** est fourni sans lubrification et avec un bouchon de remplissage, de niveau et d'évacuation de l'huile. L'utilisateur peut y verser de l'huile minérale en conservant les bouchons existants. S'il y versera de l'huile synthétique, il devra substituer les bouchons existants avec d'autres bouchons de type fermé.
Voir tableau 1 concernant les huiles et les quantités conseillées.
Voir tableau 2 concernant les charges radiales et axiales applicables au réducteur

E El reductor tamaño **852C** se suministra sin lubricante, provisto de tapones de respiración, nivel y descarga de aceite. El usuario puede utilizar aceite mineral, manteniendo los tapones existentes. Si prefiere utilizar aceite sintético deberá sustituir los tapones existentes por tapones ciegos. La prerreducción se suministra con tapones ciegos, lubricado de por vida con aceite sintético.
Ver tabla 1, para cantidades y aceites recomendados.
En la tabla 2, se encuentran las cargas radiales y axiales admitidas por el reductor.

5.40 LT	3.60 LT	3.60 LT	2.80 LT	5.90 LT	4.20 LT	Ask

AGIP Blasias 460

For all details on lubrication and plugs check our website **tab. 1**
Per maggiori dettagli su lubrificazione e tappi olio vedi il nostro sito web

RADIAL AND AXIAL LOADS

Output shaft
Albero di uscita

$F_{eq} = FR \cdot \frac{88.5}{X+38.5}$

$F_{eq} (N)$

n_2	FA	FR	n_2	FA	FR	n_2	FA	FR
300	1800	9000	140	2400	12000	70	3000	15000
250	2000	10000	120	2600	13000	40	3200	16000
200	2200	11000	85	2800	14000	15	4000	20000

On request reinforced bearings to increase loads.
A richiesta cuscinetti rinforzati per aumentare i carichi.

Input shaft
Albero in entrata

n_1	FA	FR
1400	700	3500
900	840	4200
500	900	4500

tab. 2

P852C-S8... With foot
Con piedino

Gearbox weight With flange **86.0 kg**
peso riduttore With feet **76.5 kg**

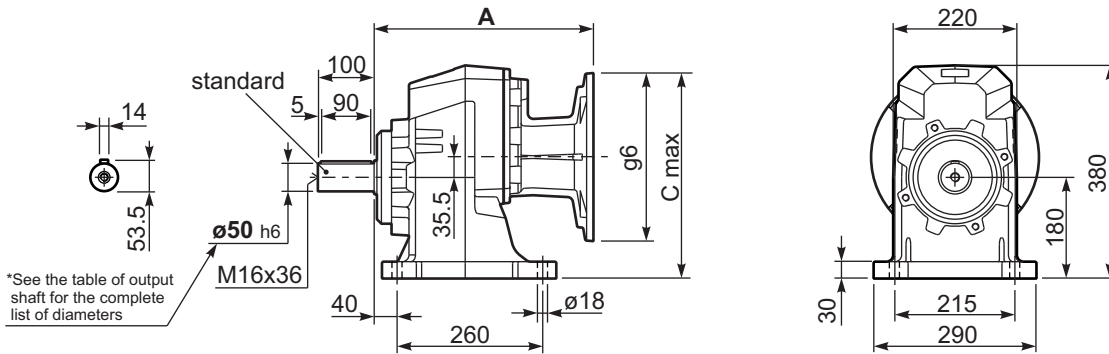

P852C-F... Output flanges
flange di uscita

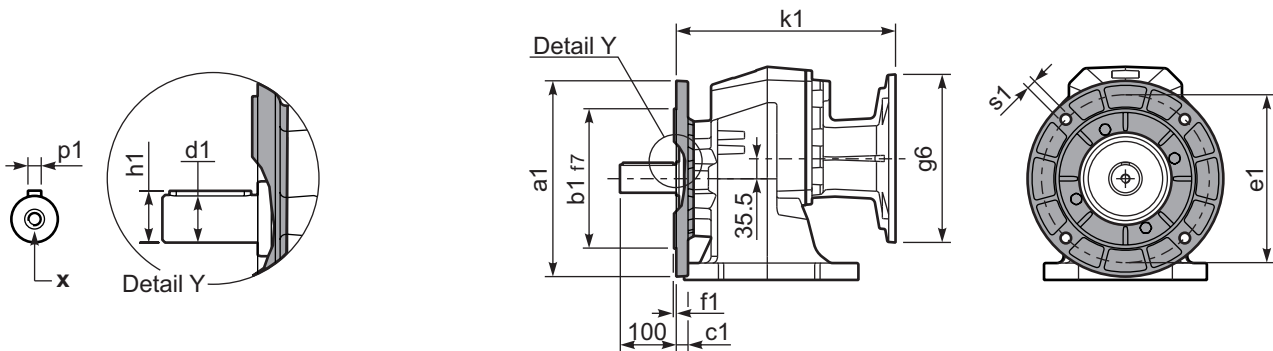

*Available output shaft / Albero di uscita

	Shaft - d1	p1	h1	x
Standard	∅ 50x100	14	53.5	M16x36
On request A richiesta	∅ 60x120	18	64	M20x42
	-	-	-	-

Available output flanges / flange di uscita

a1 ∅	b1	c1	e1	f1	s1	kit code
300	230	21	265	4	14	KC90.9.014
350	250	21	300	5	18	KC90.9.015
-	-	-	-	-	-	-

All flanges are compatible with the foot

P852C-S8... Basic gearbox
Riduttore base

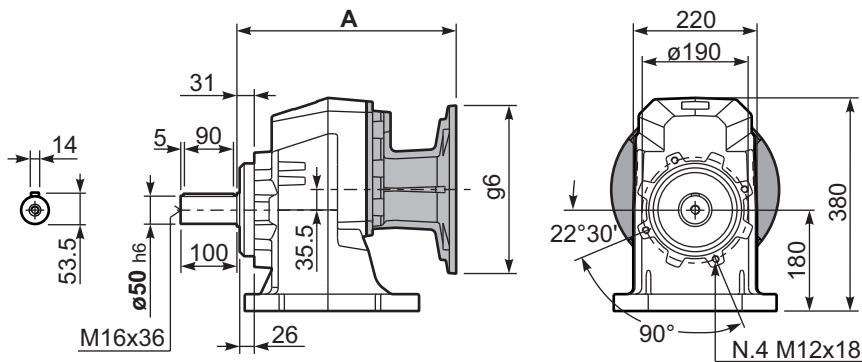

B5 Motor Flanges	A	C _{max}	g6	k1	kit code
100/112 B5	387	340.5	250	387	-
132 B5	391	365.5	300	391	-
160/180 B5	402	390.5	350	402	-

R852C-S8... Input Shaft
Albero in entrata

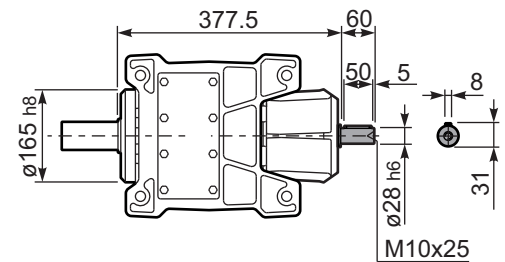



QUICK SELECTION / Selezione veloce

input speed (n_1) = 1400 min⁻¹

Output Speed n_2 [min ⁻¹]	Ratio i	Motor power P_{1M} [kW]	Output torque M_{2M} [Nm]	Service factor $f.s.$	Nominal power P_{1R} [kW]	Nominal torque M_{2R} [Nm]	Available B5 motor flanges					Available B14 motor flanges				Output Shaft 	Ratios code		
							C	D	E	F	G	R	T	U	V				
							71	80	90	100 112	132	80	90	100 112	132				
32.5	43.03	5.5	1478	1.1	5.8	1600	B									201313	standard ø50	01	
28.9	48.52	5.5	1667	0.9	5.0	1550	B									161315		02	
27.0	51.81	4	1302	1.2	4.8	1600	B									201311		03	
24.1	58.17	4	1462	1.1	4.3	1600	B									161313		04	
22.2	63.09	4	1585	1.0	3.8	1550	B									131315		05	
20.0	70.05	4	1760	1.0	4.0	1800	B									161311		06	
18.5	75.65	4	1901	0.9	3.7	1800	B									131313		ø60	07
15.4	91.09	3	1723	1.0	3.1	1800	B									131311		On request	08
12.6	111.50	2.2	1553	1.2	2.5	1800	B									111311		09	
10.5	133.91	2.2	1865	1.0	2.1	1800	B									81313		10	
8.7	161.24	1.5	1548	1.2	1.7	1800	B									81311		11	
7.6	184.40	1.1	1293	1.1	1.2	1450	B									61313		12	
6.3	222.04	1.1	1557	1.1	1.2	1750	B									61311		13	

The dynamic efficiency is **0.94** for all ratios

Motor Flanges Available
Flange Motore Disponibili

B) Supplied with Reduction Bushing
Fornito con Bussola di Riduzione

B) Available on Request without reduction bushing
Disponibile a Richiesta senza Bussola di Riduzione

C) Motor Flange Holes Position
Posizione Fori Flangia Motore

EN Unit **853C** is supplied without lubricant and equipped with a breather, level and drain plugs. User can add mineral oil keeping existing plugs. Should the user wish to fill it with synthetic oil, it is recommended to replace the existing plugs with a closed plug.
See table 1 for lubrication and recommended quantity. In table 2 please see possible radial loads and axial loads on the gearbox.

I Il riduttore tipo **853C** è fornito privo di lubrificazione con tappi di sfiato, livello e scarico olio. L'utente può immettere olio minerale mantenendo i tappi esistenti. Se immetterà olio sintetico, dovrà sostituire i tappi esistenti con altri tipo chiuso.
Tab.1 per oli e quantità consigliati.
Tab.2 carichi radiali e assiali applicabili al riduttore.

D Das Getriebe der Baugröße **853C** wird ohne Schmiermittel geliefert. Es ist jedoch mit Einfüllschraube, Überdruckventil und Ablassschraube ausgerüstet. Das benötigte mineralische Öl kann über die Einfüllschraube eingefüllt werden. Sollte synthetisches Öl bevorzugt werden, so ist sind das eingebaute Überdruckventil durch eine geschlossenen Schraube zu ersetzen.
In Tabelle 1 ist die Schmiermenge und das empfohlene Schmiermittel angegeben
In Tabelle 2 sind die zulässigen Radial - und Axialbelastungen des Getriebes aufgeführt.

F Le réducteur de type **853C** est fourni sans lubrification et avec un bouchon de remplissage, de niveau et d'évacuation de l'huile. L'utilisateur peut y verser de l'huile minérale en conservant les bouchons existants. S'il y versera de l'huile synthétique, il devra substituer les bouchons existants avec d'autres bouchons de type fermé.
Voir tableau 1 concernant les huiles et les quantités conseillées.
Voir tableau 2 concernant les charges radiales et axiales applicables au réducteur

E El reductor tamaño **853C** se suministra sin lubricante, provisto de tapones de respiración, nivel y descarga de aceite. El usuario puede utilizar aceite mineral, manteniendo los tapones existentes. Si prefiere utilizar aceite sintético deberá sustituir los tapones existentes por tapones ciegos. La prerreducción se suministra con tapones ciegos, lubricado de por vida con aceite sintético. Ver tabla 1, para cantidades y aceites recomendados. En la tabla 2, se encuentran las cargas radiales y axiales admitidas por el reductor.

B3	B6	B7	B8	V5	V6	V8
5.50 LT	3.80 LT	3.80 LT	3.20 LT	7.00 LT	4.60 LT	Ask
AGIP Blasias 460						

For all details on lubrication and plugs check our website [tab. 1](#)
Per maggiori dettagli su lubrificazione e tappi olio vedi il nostro sito web

RADIAL AND AXIAL LOADS

Output shaft
Albero di uscita

$F_{eq} = FR \cdot \frac{88.5}{X+38.5}$

n_2	FA	FR	n_2	FA	FR	n_2	FA	FR
300	1800	9000	140	2400	12000	70	3000	15000
250	2000	10000	120	2600	13000	40	3200	16000
200	2200	11000	85	2800	14000	15	4000	20000

On request reinforced bearings to increase loads.
A richiesta cuscinetti rinforzati per aumentare i carichi.

Input shaft
Albero in entrata

n_1	FA	FR
1400	450	2250
900	500	2500
500	600	3000

tab. 2

P853CS8... With foot
Con piedino

Gearbox weight With flange **80.5 kg**
peso riduttore With feet **71.0 kg**

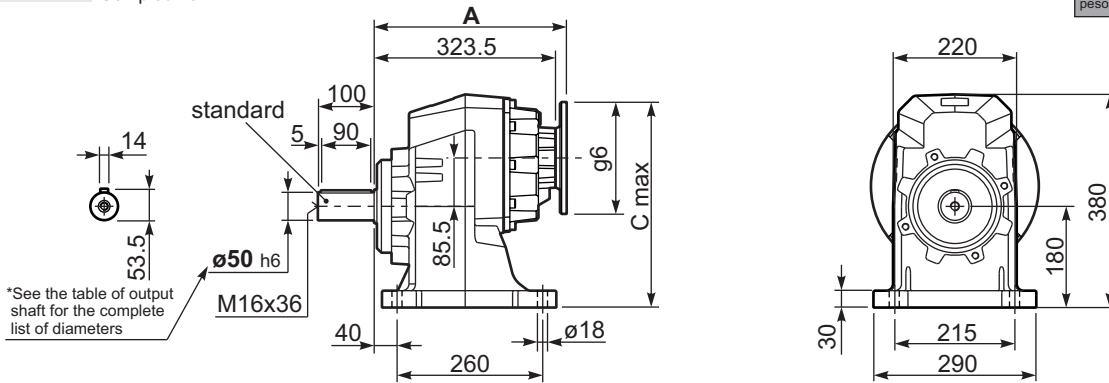

P853C-F... Output flanges
flange di uscita

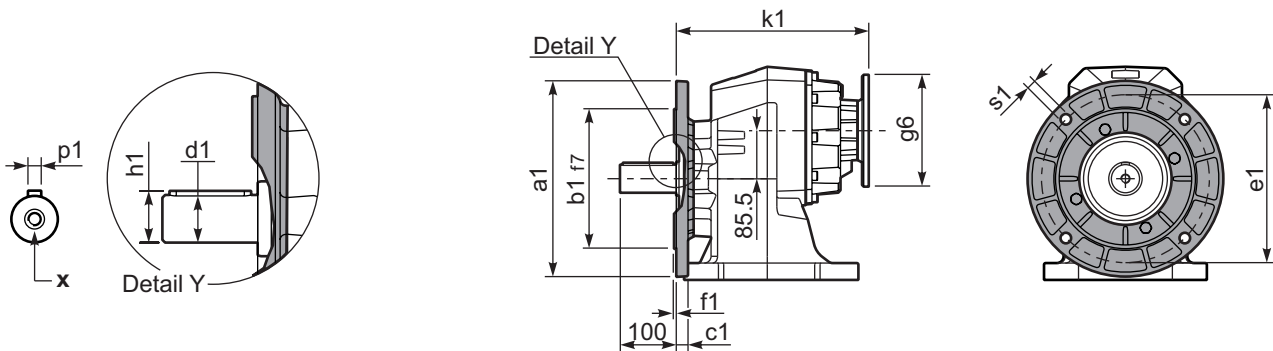

*Available output shaft / Albero di uscita

	Shaft - d1	p1	h1	x
Standard	ø 50x100	14	53.5	M16x36
On request A richiesta	ø 60x120	18	64	M20x42
	-	-	-	-

Available output flanges / flange di uscita

a1 ø	b1	c1	e1	f1	s1	kit code
300	230	21	265	4	14	KC90.9.014
350	250	21	300	5	18	KC90.9.015
-	-	-	-	-	-	-

All flanges are compatible with the foot

P853CS8... Basic gearbox
Riduttore base

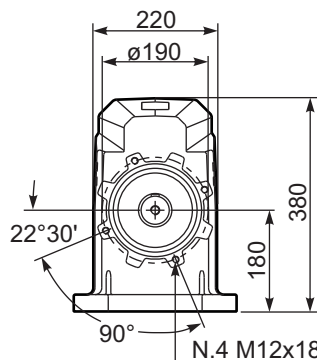
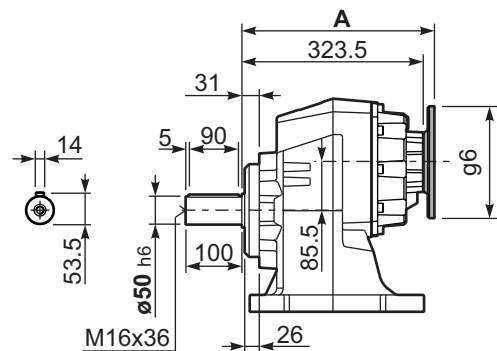

R853CS8... Input Shaft
Albero in entrata

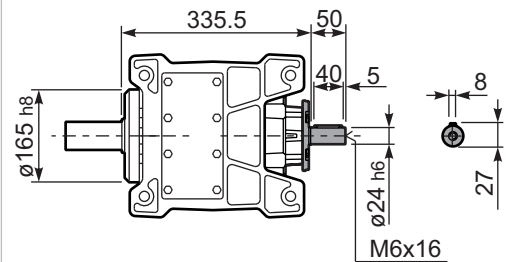

B5 Motor Flanges	A	C _{max}	g6	k1	kit code
71 B5	342	345.5	160	342	KC023.4.041
80/90 B5	344	365.5	200	344	KC023.4.042
100/112 B5	353	390.5	250	353	KC023.4.043
132 B5	371	415.5	300	371	KC50.4.043

B14 Motor Flanges	A	C _{max}	g6	k1	kit code
80 B14	344	325.5	120	344	KC085.4.046
90 B14	344	335.5	140	344	KC085.4.045
100/112 B14	353	345.5	160	353	KC085.4.047
132 B14	371	365.5	200	371	KC50.4.041



QUICK SELECTION / Selezione veloce

input speed (n_1) = 1400 min⁻¹

Output Speed n_2 [min ⁻¹]	Ratio i	Motor power P_{1M} [kW]	Output torque M_{2M} [Nm]	Service factor f.s.	Nominal power P_{1R} [kW]	Nominal torque M_{2R} [Nm]	Available B5 motor flanges		B14 motor flanges				Output Shaft		
							H	I	-	-	-	-			Ratios code
							160	180	-	-	-	-			
528	2.65	22	374	1.7	36.7	650			not available				2361	standard	01
409	3.42	22	483	1.6	32.8	750							1965	ø60	02
304	4.60	22	649	1.5	30.9	950							1569		03
256	5.46	22	771	1.3	27.4	1000							1371	ø50	04
211	6.64	22	937	1.3	26.5	1175							1173	On request	05

The dynamic efficiency is **0.98** for all ratios

A) Motor Flanges Available
Flange Motore Disponibili

B) Supplied with Reduction Bushing
Fornito con Bussola di Riduzione

B) Available on Request without reduction bushing
Disponibile a Richiesta senza Bussola di Riduzione

C) Motor Flange Holes Position
Posizione Fori Flangia Motore

EN Unit **901C** is supplied without lubricant and equipped with a breather, level and drain plugs. User can add mineral oil keeping existing plugs. Should the user wish to fill it with synthetic oil, it is recommended to replace the existing plugs with a closed plug. See table 1 for lubrication and recommended quantity. In table 2 please see possible radial loads and axial loads on the gearbox.

I Il riduttore tipo **901C** è fornito privo di lubrificazione con tappi di sfiato, livello e scarico olio. L'utente può immettere olio minerale mantenendo i tappi esistenti. Se immetterà olio sintetico, dovrà sostituire i tappi esistenti con altri tipo chiuso. Tab.1 per oli e quantità consigliati. Tab.2 carichi radiali e assiali applicabili al riduttore.

D Das Getriebe der Baugröße **901C** wird ohne Schmiermittel geliefert. Es ist jedoch mit Einfüllschraube, Überdruckventil und Ablassschraube ausgerüstet. Das benötigte mineralische Öl kann über die Einfüllschraube eingefüllt werden. Sollte synthetisches Öl bevorzugt werden, so ist sind das eingebaute Überdruckventil durch eine geschlossenen Schraube zu ersetzen. In Tabelle 1 ist die Schmiermenge und das empfohlene Schmiermittel angegeben. In Tabelle 2 sind die zulässigen Radial - und Axialbelastungen des Getriebes aufgeführt.

F Le réducteur de type **901C** est fourni sans lubrification et avec un bouchon de remplissage, de niveau et d'évacuation de l'huile. L'utilisateur peut y verser de l'huile minérale en conservant les bouchons existants. S'il y versera de l'huile synthétique, il devra substituer les bouchons existants avec d'autres bouchons de type fermé. Voir tableau 1 concernant les huiles et les quantités conseillées. Voir tableau 2 concernant les charges radiales et axiales applicables au réducteur.

E El reductor tamaño **901C** se suministra sin lubricante, provisto de tapones de respiración, nivel y descarga de aceite. El usuario puede utilizar aceite mineral, manteniendo los tapones existentes. Si prefiere utilizar aceite sintético deberá sustituir los tapones existentes por tapones ciegos. La prerreducción se suministra con tapones ciegos, lubricado de por vida con aceite sintético. Ver tabla 1, para cantidades y aceites recomendados. En la tabla 2, se encuentran las cargas radiales y axiales admitidas por el reductor.

B3	B6	B7	B8	V5	V6	V8
5.90 LT	3.80 LT	3.80 LT	3.50 LT	6.80 LT	4.50 LT	Ask

AGIP Blasias 460

For all details on lubrication and plugs check our website **tab. 1**
Per maggiori dettagli su lubrificazione e tappi olio vedi il nostro sito web

RADIAL AND AXIAL LOADS

Output shaft
Albero di uscita

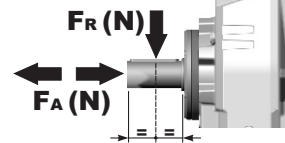

$$F_{eq} = FR \cdot \frac{88.5}{X+38.5}$$

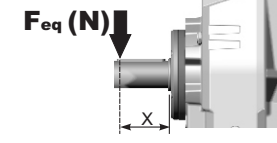

n_2	FA	FR	n_2	FA	FR	n_2	FA	FR
300	2070	10350	140	2760	13800	70	3450	17250
250	2300	11500	120	2990	14950	40	3680	18400
200	2530	12650	85	3220	16100	15	4600	23000

On request reinforced bearings to increase loads.
A richiesta cuscinetti rinforzati per aumentare i carichi.

tab. 2



QUICK SELECTION / Selezione veloce

input speed (n_1) = 1400 min⁻¹

Output Speed n_2 [min ⁻¹]	Ratio i	Motor power P_{1M} [kW]	Output torque M_{2M} [Nm]	Service factor $f.s.$	Nominal power P_{1R} [kW]	Nominal torque M_{2R} [Nm]	B5 motor flanges				B14 motor flanges				Output Shaft			
							-F	-G	-H	-I	-	-	-	-			Ratios code	
							100 112	132	160	180	-	-	-	-				
234	5.98	22	827	1.2	25.5	1000	B								3015	standard ø60	01	
197	7.10	22	982	1.2	25.3	1175	B								3013		02	
162	8.63	22	1193	1.1	23.9	1350	B								3011		03	
124	11.27	18.5	1310	1.1	20.3	1500	B								2015		04	
105	13.38	18.5	1555	1.1	19.4	1700	B								2013		05	
92	15.24	18.5	1771	1.1	19.0	1900	B								1615		06	
86	16.26	18.5	1889	1.1	19.7	2100	B								2011		07	
77	18.09	18.5	2102	1.0	17.7	2100	B								1613		08	
71	19.82	15	1865	1.1	15.9	2060	B								1315		09	
64	21.98	15	2069	1.0	14.6	2100	B								1611		On request	10
60	23.53	15	2214	0.9	13.6	2100	B								1313			11
58	24.25	11	1677	1.2	12.2	1940	B								1115			12
48.6	28.80	11	1991	1.1	11.1	2100	B								1113			13
40.0	34.99	9	2063	1.0	9.2	2100	B								1111			14
33.6	41.64	7.5	1976	1.0	7.2	1960	B								813			15
27.7	50.60	5.5	1774	1.2	6.3	2100	B								811			16

The dynamic efficiency is **0.96** for all ratios

Motor Flanges Available Flange Motore Disponibili
 Supplied with Reduction Bushing Fornito con Bussola di Riduzione
 Available on Request without reduction bushing Disponibile a Richiesta senza Bussola di Riduzione
 Motor Flange Holes Position Posizione Fori Flangia Motore

EN Unit **902C** is supplied without lubricant and equipped with a breather, level and drain plugs. User can add mineral oil keeping existing plugs. Should the user wish to fill it with synthetic oil, it is recommended to replace the existing plugs with a closed plug. See table 1 for lubrication and recommended quantity. In table 2 please see possible radial loads and axial loads on the gearbox.

I Il riduttore tipo **902C** è fornito privo di lubrificazione con tappi di sfiato, livello e scarico olio. L'utente può immettere olio minerale mantenendo i tappi esistenti. Se immetterà olio sintetico, dovrà sostituire i tappi esistenti con altri tipo chiuso. Tab.1 per oli e quantità consigliati. Tab.2 carichi radiali e assiali applicabili al riduttore.

D Das Getriebe der Baugröße **902C** wird ohne Schmiermittel geliefert. Es ist jedoch mit Einfüllschraube, Überdruckventil und Ablassschraube ausgerüstet. Das benötigte mineralische Öl kann über die Einfüllschraube eingefüllt werden. Sollte synthetisches Öl bevorzugt werden, so ist sind das eingebaute Überdruckventil durch eine geschlossenen Schraube zu ersetzen. In Tabelle 1 ist die Schmiermenge und das empfohlene Schmiermittel angegeben. In Tabelle 2 sind die zulässigen Radial - und Axialbelastungen des Getriebes aufgeführt.

F Le réducteur de type **902C** est fourni sans lubrification et avec un bouchon de remplissage, de niveau et d'évacuation de l'huile. L'utilisateur peut y verser de l'huile minérale en conservant les bouchons existants. S'il y versera de l'huile synthétique, il devra substituer les bouchons existants avec d'autres bouchons de type fermé. Voir tableau 1 concernant les huiles et les quantités conseillées. Voir tableau 2 concernant les charges radiales et axiales applicables au réducteur

E El reductor tamaño **902C** se suministra sin lubricante, provisto de tapones de respiración, nivel y descarga de aceite. El usuario puede utilizar aceite mineral, manteniendo los tapones existentes. Si prefiere utilizar aceite sintético deberá sustituir los tapones existentes por tapones ciegos. La prerreducción se suministra con tapones ciegos, lubricado de por vida con aceite sintético. Ver tabla 1, para cantidades y aceites recomendados. En la tabla 2, se encuentran las cargas radiales y axiales admitidas por el reductor.

B3	B6	B7	B8	V5	V6	V8
5.90 LT	3.80 LT	3.80 LT	3.40 LT	6.70 LT	4.40 LT	Ask

AGIP Blasia 460

For all details on lubrication and plugs check our website **tab. 1**
Per maggiori dettagli su lubrificazione e tappi olio vedi il nostro sito web

RADIAL AND AXIAL LOADS

Output shaft
Albero di uscita

$F_{eq} = F_R \cdot \frac{88.5}{X+38.5}$

Input shaft
Albero in entrata

n_2	FA	FR	n_2	FA	FR	n_2	FA	FR
300	2070	10350	140	2760	13800	70	3450	17250
250	2300	11500	120	2990	14950	40	3680	18400
200	2530	12650	85	3220	16100	15	4600	23000

On request reinforced bearings to increase loads.
A richiesta cuscinetti rinforzati per aumentare i carichi.

n_1	FA	FR
1400	700	3500
900	840	4200
500	900	4500

tab. 2

P902C**S8**... With feet
Con piedini

Gearbox weight **98.5 kg**
peso riduttore With feet **107.0 kg**

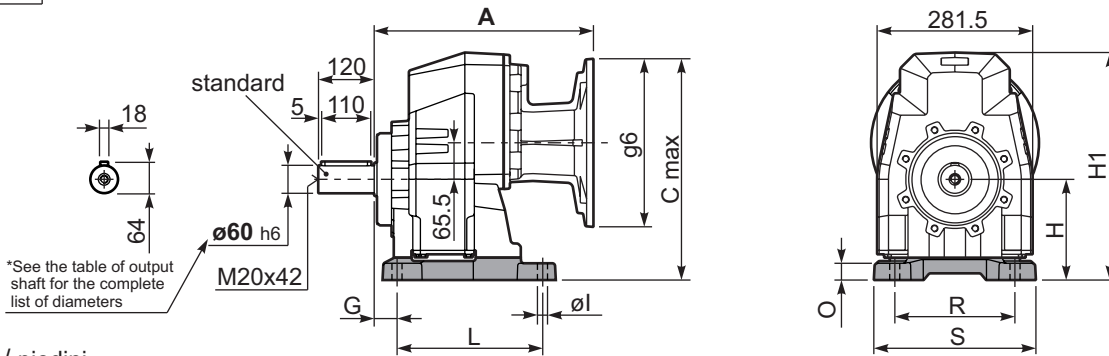

Feet / piedini

Feet Code	Market reference	G	H	R	L	S	H1	O	øI	B5 max. Flange	kit code
B6	612/3	25	195	250	180	300	422	25	18	-	KC90.9.022
S8	87	40	180	215	260	290	407	30	18	-	KC90.9.024
S9	97	40	225	250	310	340	452	45	22	-	KC90.9.026
H7	027/273	40	225	250	245	300	452	55	22	-	KC90.9.023
HS	-	40	175	215	260	290	402	25	18	-	KC90.9.025

P902C-**F**... Output flanges
flange di uscita

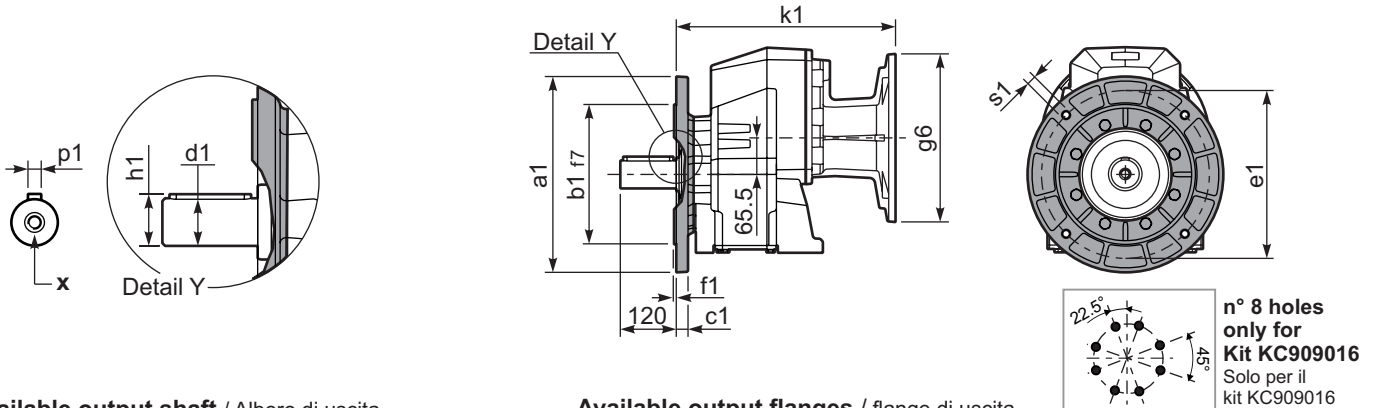

*Available output shaft / Albero di uscita

	Shaft - d1	p1	h1	x
Standard	ø 60x120	18	64	M20x42
On request A richiesta	ø 50x100	14	53.5	M16x36
	-	-	-	-

Available output flanges / flange di uscita

a1 ø	b1	c1	e1	f1	s1	kit code
300	230	21	265	4	14	KC90.9.014
350	250	21	300	5	18	KC90.9.015
450	350	22	400	5	18	KC90.9.016

With flange and feet only on request. Ask for compatibility

P902C-**N**... Basic gearbox
Riduttore base

R902C-**N**... Input Shaft
Albero in entrata

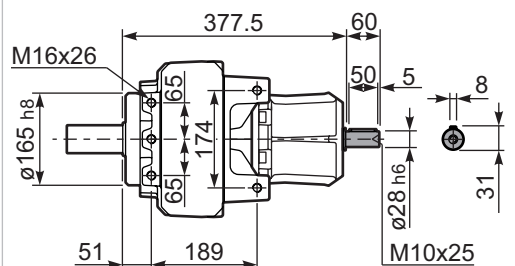
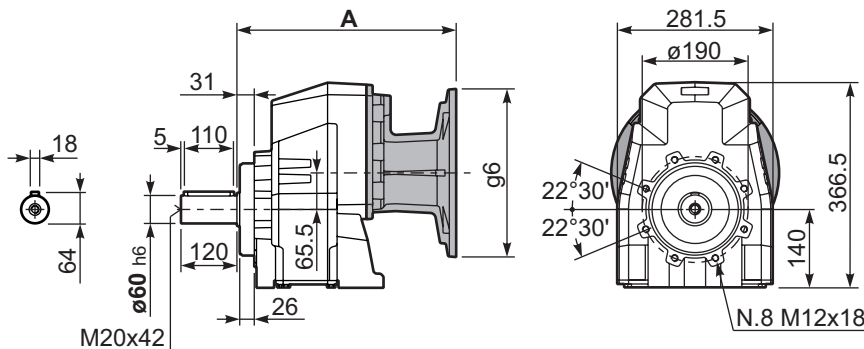

B5 Motor Flanges	A	C _{max}	g6	k1	kit code
100/112 B5	387	415.5	250	387	-
132 B5	391	440.5	300	391	-
160/180 B5	402	465.5	350	402	-



QUICK SELECTION / Selezione veloce

input speed (n_1) = 1400 min⁻¹

Output Speed n_2 [min ⁻¹]	Ratio i	Motor power P_{1M} [kW]	Output torque M_{2M} [Nm]	Service factor f.s.	Nominal power P_{1R} [kW]	Nominal torque M_{2R} [Nm]	Available B5 motor flanges					Available B14 motor flanges				Output Shaft \varnothing	Ratios code
							C	D	E	F	G	R	T	U	V		
							71	80	90	100 112	132	80	90	100 112	132		
28.8	48.55	7.5	2257	0.9	6.7	2100	B									201315	01
24.3	57.64	5.5	1980	1.1	5.7	2100	B									201313	02
21.3	65.64	5.5	2255	0.9	5.0	2100	B									161315	03
20.0	70.04	4	1760	1.2	4.7	2100	B									201311	04
18.0	77.93	4	1958	1.1	4.2	2100	B									161313	05
16.4	85.36	4	2145	1.0	3.8	2100	B									131315	06
14.8	94.70	4	2380	0.9	3.5	2100	B									161311	07
13.8	101.35	3	1917	1.1	3.2	2100	B									131313	08
11.4	123.15	3	2330	0.9	2.7	2100	B									131311	09
9.3	150.73	2.2	2100	1.0	2.2	2100	B									111311	10
7.8	179.39	1.5	1722	1.2	1.8	2100	B									81313	11
6.4	217.98	1.5	2093	1.0	1.5	2100	B									81311	12
5.7	247.03	1.1	1732	1.1	1.2	1950	B									61313	13
4.7	300.17	1.1	2105	1.0	1.1	2100	B									61311	14

The dynamic efficiency is **0.94** for all ratios

Motor Flanges Available
Flange Motore Disponibili

B) Supplied with Reduction Bushing
Fornito con Bussola di Riduzione

B) Available on Request without reduction bushing
Disponibile a Richiesta senza Bussola di Riduzione

C) Motor Flange Holes Position
Posizione Fori Flangia Motore

EN Unit **903C** is supplied without lubricant and equipped with a breather, level and drain plugs. User can add mineral oil keeping existing plugs. Should the user wish to fill it with synthetic oil, it is recommended to replace the existing plugs with a closed plug.
See table 1 for lubrication and recommended quantity.
In table 2 please see possible radial loads and axial loads on the gearbox.

I Il riduttore tipo **903C** è fornito privo di lubrificazione con tappi di sfiato, livello e scarico olio. L'utente può immettere olio minerale mantenendo i tappi esistenti. Se immetterà olio sintetico, dovrà sostituire i tappi esistenti con altri tipo chiuso.
Tab.1 per oli e quantità consigliati.
Tab.2 carichi radiali e assiali applicabili al riduttore.

D Das Getriebe der Baugröße **903C** wird ohne Schmiermittel geliefert. Es ist jedoch mit Einfüllschraube, Überdruckventil und Ablassschraube ausgerüstet. Das benötigte mineralische Öl kann über die Einfüllschraube eingefüllt werden. Sollte synthetisches Öl bevorzugt werden, so ist sind das eingebaute Überdruckventil durch eine geschlossenen Schraube zu ersetzen.
In Tabelle 1 ist die Schmiermenge und das empfohlene Schmiermittel angegeben
In Tabelle 2 sind die zulässigen Radial - und Axialbelastungen des Getriebes aufgeführt.

F Le réducteur de type **903C** est fourni sans lubrification et avec un bouchon de remplissage, de niveau et d'évacuation de l'huile. L'utilisateur peut y verser de l'huile minérale en conservant les bouchons existants. S'il y versera de l'huile synthétique, il devra substituer les bouchons existants avec d'autres bouchons de type fermé.
Voir tableau 1 concernant les huiles et les quantités conseillées.
Voir tableau 2 concernant les charges radiales et axiales applicables au réducteur

E El reductor tamaño **903C** se suministra sin lubricante, provisto de tapones de respiración, nivel y descarga de aceite. El usuario puede utilizar aceite mineral, manteniendo los tapones existentes. Si prefiere utilizar aceite sintético deberá sustituir los tapones existentes por tapones ciegos. La prerreducción se suministra con tapones ciegos, lubricado de por vida con aceite sintético.
Ver tabla 1, para cantidades y aceites recomendados.
En la tabla 2, se encuentran las cargas radiales y axiales admitidas por el reductor.

B3	B6	B7	B8	V5	V6	V8
6.00 LT	4.10 LT	4.10 LT	3.70 LT	7.30 LT	4.90 LT	Ask

AGIP Blasias 460

For all details on lubrication and plugs check our website **tab. 1**
Per maggiori dettagli su lubrificazione e tappi olio vedi il nostro sito web

RADIAL AND AXIAL LOADS

Output shaft
Albero di uscita

$F_{eq} = FR \cdot \frac{88.5}{X+38.5}$

n_2	FA	FR	n_2	FA	FR	n_2	FA	FR
300	2070	10350	140	2760	13800	70	3450	17250
250	2300	11500	120	2990	14950	40	3680	18400
200	2530	12650	85	3220	16100	15	4600	23000

On request reinforced bearings to increase loads.
A richiesta cuscinetti rinforzati per aumentare i carichi.

Input shaft
Albero di entrata

n_1	FA	FR
1400	450	2250
900	500	2500
500	600	3000

tab. 2

P903C**S8**... With feet
Con piedini

Gearbox weight **86.0 kg**
peso riduttore With flange
With feet **94.5 Kg**

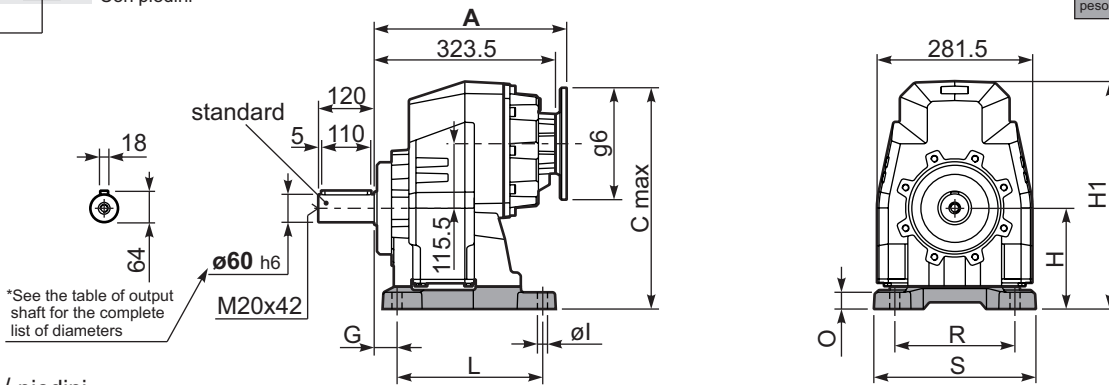

Feet / piedini

Feet Code	Market reference	G	H	R	L	S	H1	O	øl	B5 max. Flange	kit code
B6	612/3	25	195	250	180	300	422	25	18	-	KC90.9.022
S8	87	40	180	215	260	290	407	30	18	-	KC90.9.024
S9	97	40	225	250	310	340	452	45	22	-	KC90.9.026
H7	027/273	40	225	250	245	300	452	55	22	-	KC90.9.023
HS	-	40	175	215	260	290	402	25	18	-	KC90.9.025

P903C-**F**... Output flanges
flange di uscita

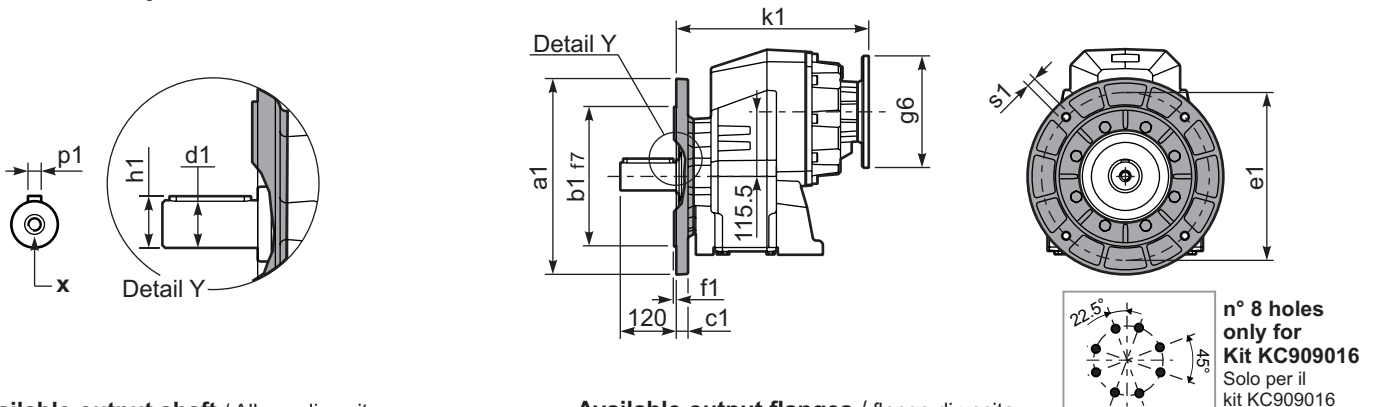

*Available output shaft / Albero di uscita

	Shaft - d1	p1	h1	x
Standard	ø 60x120	18	64	M20x42
On request A richiesta	ø 50x100	14	53.5	M16x36

Available output flanges / flange di uscita

a1 ø	b1	c1	e1	f1	s1	kit code
300	230	21	265	4	14	KC90.9.014
350	250	21	300	5	18	KC90.9.015
450	350	22	400	5	18	KC90.9.016

With flange and feet only on request. Ask for compatibility

P903C-**N**... Basic gearbox
Riduttore base

R903C-**N**... Input Shaft
Albero in entrata

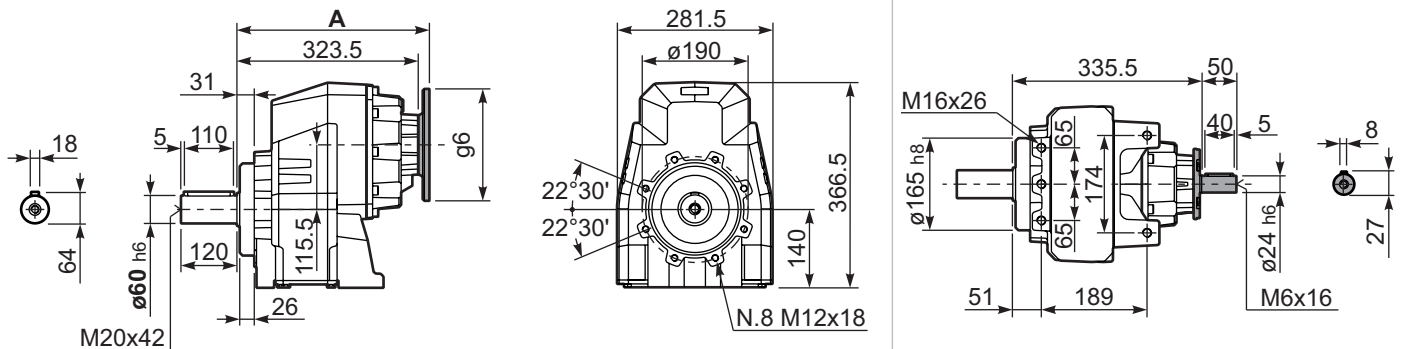

B5 Motor Flanges	A	C _{max}	g6	k1	kit code
71 B5	342	420.5	160	342	KC023.4.041
80/90 B5	344	440.5	200	344	KC023.4.042
100/112 B5	353	465.5	250	353	KC023.4.043
132 B5	371	490.5	300	371	KC50.4.043

B14 Motor Flanges	A	C _{max}	g6	k1	kit code
80 B14	344	400.5	120	344	KC085.4.046
90 B14	344	410.5	140	344	KC085.4.045
100/112 B14	353	420.5	160	353	KC085.4.047
132 B14	371	440.5	200	371	KC50.4.041

Aluminum & cast iron shaft mounted gearboxes

A modular and compact product

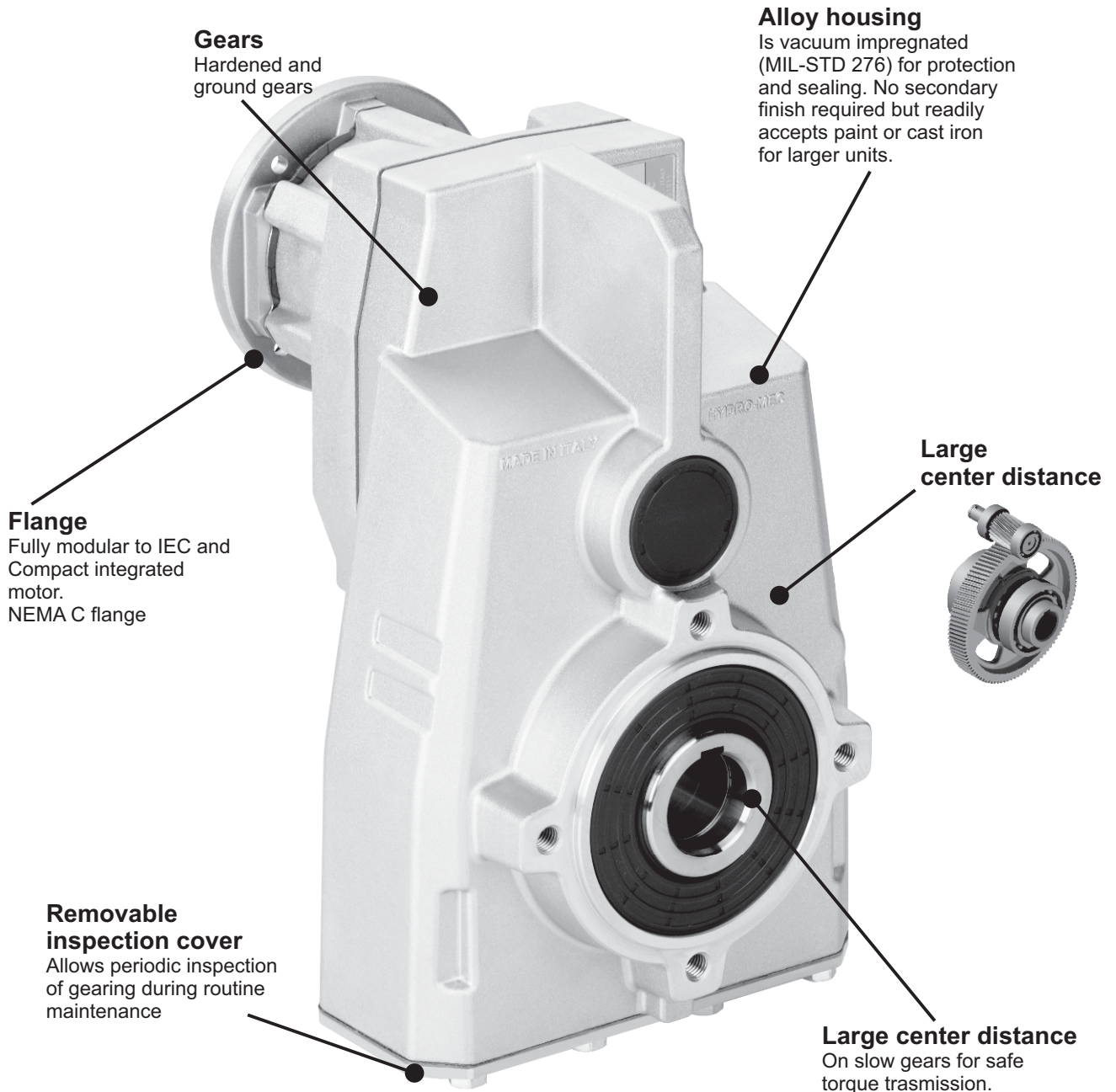

Single-piece aluminum / Cast Iron housing

Combines light weight with high tensile strength. Precision machined for alignment of bearings and gearing

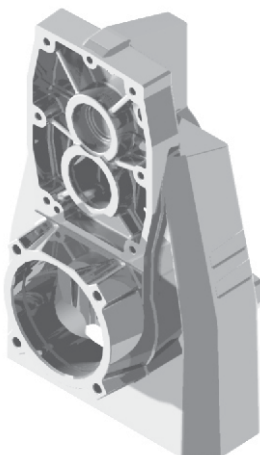
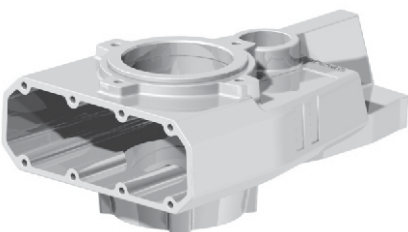

World wide sales network.

Specific type datasheet on page...

On page / A pagina / Auf Seite / À la page / En la página

1 Stage

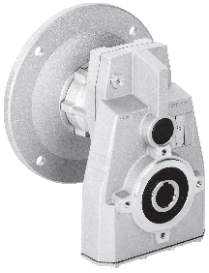

Types / Tipi /
Tipen / Types /
Tipos

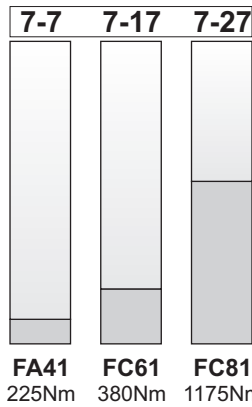

On page / A pagina / Auf Seite / À la page / En la página

2 and 3 Stage



Types / Tipi /
Tipen / Types /
Tipos

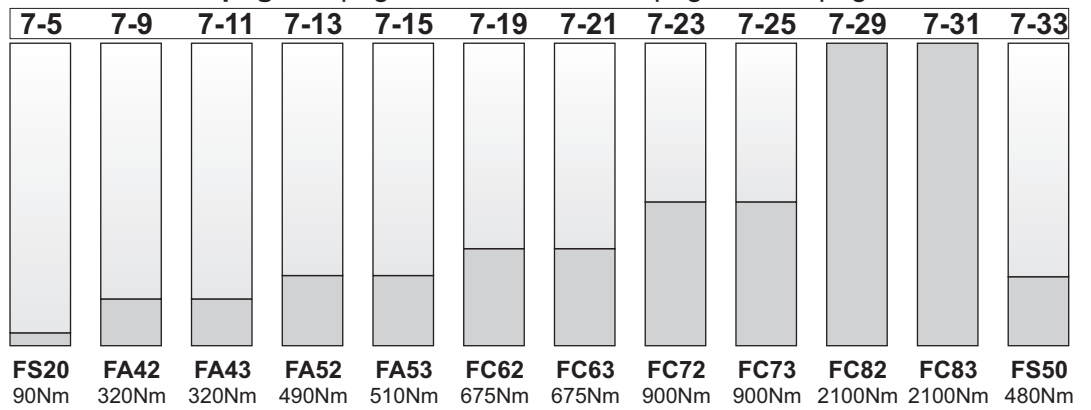

On page / A pagina / Auf Seite / À la page / En la página

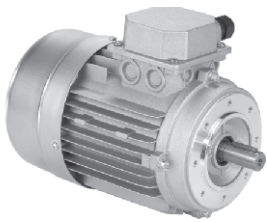

Types / Tipi /
Tipen / Types /
Tipos

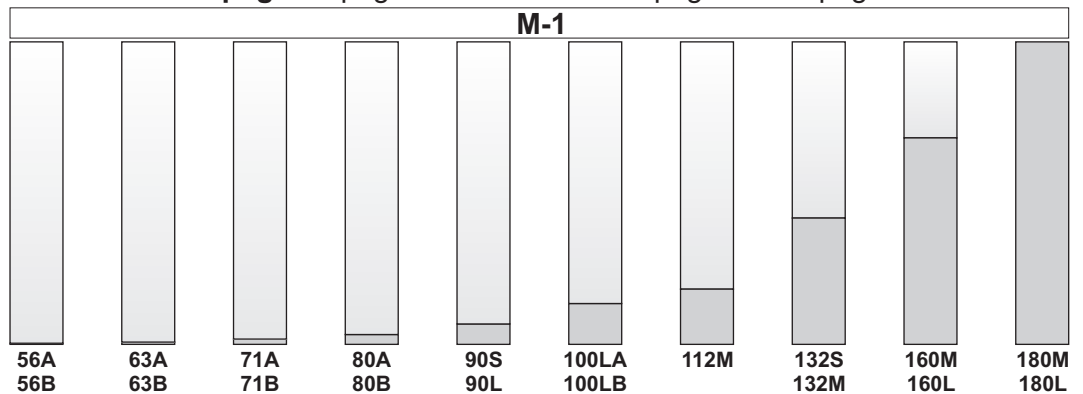

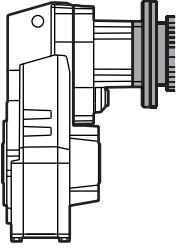
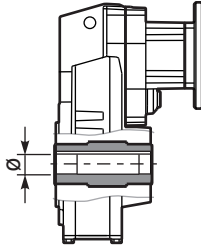
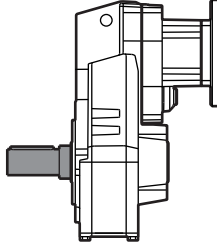
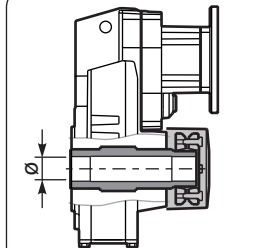
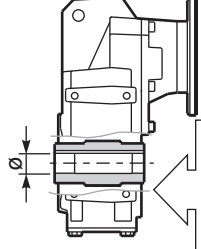

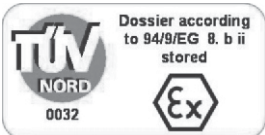

Type - Tipo - Typ Type - Tipo	Size - Grandezza - Grösse Taille - Tomajo	Mounting - Montaggio Montage - Fixation Tipo de montaje	Rapporto - Ratio Untersetzung Reduction - Relacion
M	FA42	C	10.04
<p>Shaft mounted helical Riduttori ad assi paralleli</p>  <p>With IEC motor</p> <p>M</p>	<p>1 Stage Riduzione Stufe Trains Etapa</p> <p>2 Stages Riduzioni Stufen Trains Etapas</p> <p>3 Stages Riduzioni Stufen Trains Etapas</p> <p>Aluminum/Alluminio/Aluminium/Aluminio</p> <p>FA41</p> <p>FA42 FA52</p> <p>FA43 FA53</p> <p>FS20</p> <p>FS50</p>	 <p>Hollow output shaft</p> <p>C</p>  <p>Single output shaft</p> <p>A</p>	<p>See technical data table</p> <p>Vedi tabella dati tecnici.</p> <p>Technisches Datenblatt beachten</p> <p>Voir Tableau données techniques</p> <p>Ver tabla datos técnicos</p>
<p>With motor flange</p> <p>P</p>			
<p>With male input shaft</p> <p>R</p>	<p>Cast Iron/Ghisa/Grauguss/Fonle/Fundicion</p> <p>FC61 FC81</p> <p>FC62 FC72 FC82</p> <p>FC63 FC73 FC83</p>	 <p>Shrink Disk</p> <p>D</p> <p>Only on request for Q.ty A richiesta per quantità</p>	
<p>Modular base</p> <p>B</p>		 <p>Stainless steel hub</p> <p>I</p> <p>On request for q.ty</p> <p>Stainless steel hub Mozzo in acciaio Inox Edelstahlhohlwelle Moyeu en acier Inox Nucleo corona de acero Inox</p>	

7

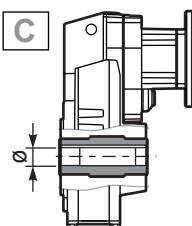
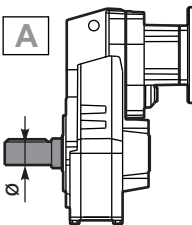
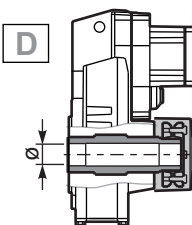
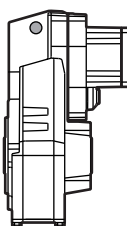
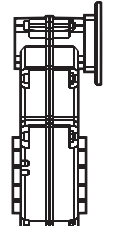
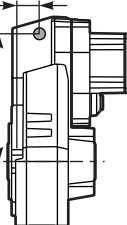
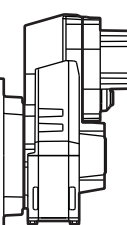
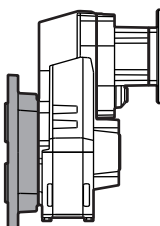
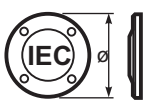

On request we can deliver our products according to the ATEX
 A richiesta possiamo fornire i nostri prodotti secondo le normative ATEX
 Auf Anfrage können wir unsere Produkte den Richtlinien ATEX entsprechend liefern
 Sur demande nos produits peuvent se conformer à la réglementation ATEX
 A pedido, se pueden enviar nuestros productos de acuerdo con las normas ATEX.

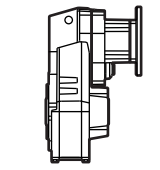
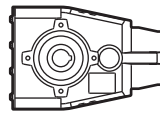
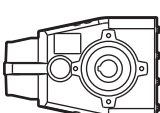
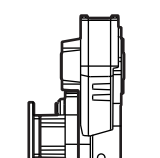
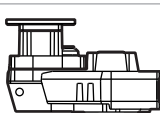
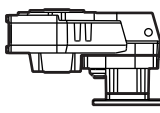
Output shaft Albero uscita Abtriebswelle Arbre de sortie Eje en salida	Type - Tipo - Typ Types - Tipo	Output flange Flangia uscita Ausgangsflansch Bride de sortie Brida en salida	Motor size - Grandezza motore Motor Grösse Grandeur moteur - Tamaño motor	Terminal box position Posizione morsettera Klemmkastenlage Position boîte à bornes Posición caja de bornes	Mounting position Posizione montaggio Einbaulage Position de montage Posición de montaje																																												
<p>D</p>  <p>STANDARD Only on request for Q.ty A richiesta per quantità</p> <p>FS20</p> <p>B → $\varnothing 20$</p> <p>FA41 FA42 FA43 FS50</p> <p>D → $\varnothing 30$</p> <p>E → $\varnothing 35$</p> <p>FA52 FA53 FC61 FC62 FC63</p> <p>E → $\varnothing 35$</p> <p>F → $\varnothing 40$</p> <p>FC72 FC73</p> <p>F → $\varnothing 40$</p> <p>G → $\varnothing 45$</p> <p>FC81 FC82 FC83</p> <p>H → $\varnothing 50$</p> <p>I → $\varnothing 55$</p> <p>A</p>  <p>Single output shaft</p> <p>M FA41/2/3 → $\varnothing 30$</p> <p>N FA52/3 FC61/2/3 → $\varnothing 35$</p> <p>O FC72/3 → $\varnothing 40$</p> <p>K FC81/2/3 → $\varnothing 50$</p> <p>D</p>  <p>Shrink disk</p> <p>Q FA42/3 → $\varnothing 30$</p> <p>T FA52/3 FC62/3 → $\varnothing 35$</p> <p>U FC72/3 → $\varnothing 40$</p> <p>V FC82/3 → $\varnothing 50$</p>	<p>ST</p>  <p>ST</p> <p>Foro standard Standard bore</p>  <p>only for FS20</p> <p>ST</p> <p>Senza braccio di reazione Without reaction arm</p>  <p>Available torque arms, see our web site.</p> <p>Bracci di reazione disponibili, vedi il nostro sito web.</p> <p>S..</p>  <p>-F</p> <p>Whit output flange con flangia uscita</p>	<p>N</p>  <p>N Senza flangia Without flange</p> <p>FS20</p> <p>1 → $\varnothing 140$</p> <p>FA41 FA42 FA43</p> <p>2 → $\varnothing 160$</p> <p>3 → $\varnothing 200$</p> <p>4 → $\varnothing 250$</p> <p>FA52 FA53 FC61 FC62 FC63</p> <p>4 → $\varnothing 250$</p> <p>5 → $\varnothing 300$</p> <p>FC72 FC73</p> <p>4 → $\varnothing 250$</p> <p>5 → $\varnothing 300$</p> <p>6 → $\varnothing 350$</p> <p>FC81 FC82 FC83</p> <p>5 → $\varnothing 300$</p> <p>6 → $\varnothing 350$</p> <p>7 → $\varnothing 400$</p>	<p>-C</p> <p>Standard Flange Flangia Standard</p>  <table border="1"> <tr> <td>B5</td> <td>B14</td> </tr> <tr> <td>-A=56 ($\varnothing 120$)</td> <td>-O=56 ($\varnothing 80$)</td> </tr> <tr> <td>-B=63 ($\varnothing 140$)</td> <td>-P=63 ($\varnothing 90$)</td> </tr> <tr> <td>-C=71 ($\varnothing 160$)</td> <td>-Q=71 ($\varnothing 105$)</td> </tr> <tr> <td>-D=80 ($\varnothing 200$)</td> <td>-R=80 ($\varnothing 120$)</td> </tr> <tr> <td>-E=90 ($\varnothing 200$)</td> <td>-T=90 ($\varnothing 140$)</td> </tr> <tr> <td>-F=100+112 ($\varnothing 250$)</td> <td>-U=100+112 ($\varnothing 160$)</td> </tr> <tr> <td>-G=132 ($\varnothing 300$)</td> <td>-V=132 ($\varnothing 200$)</td> </tr> <tr> <td>-H=160 ($\varnothing 350$)</td> <td></td> </tr> <tr> <td>-I=180 ($\varnothing 350$)</td> <td></td> </tr> </table> <p>Type R / Tipo R</p> <table border="1"> <tr> <td>FA43 FS20 FS50</td> <td>FA42 FA53 FC63 FC73</td> </tr> <tr> <td>-1 → $\varnothing 14$</td> <td>-2 → $\varnothing 19$</td> </tr> <tr> <td>FA52 FC62 FC72 FC83</td> <td>FC82</td> </tr> <tr> <td>-3 → $\varnothing 24$</td> <td>-4 → $\varnothing 28$</td> </tr> </table> <p>Without flange / Senza flangia</p> <table border="1"> <tr> <td>FA43 FS20 FS50</td> <td>FA42 FA53 FC63 FC73</td> </tr> <tr> <td>-Z → $\varnothing 9$ (56B5)</td> <td>-1 → $\varnothing 14$ (71B5)</td> </tr> <tr> <td>-0 → $\varnothing 11$ (63B5)</td> <td>-2 → $\varnothing 19$ (80B5)</td> </tr> <tr> <td>-1 → $\varnothing 14$ (71B5)</td> <td>-3 → $\varnothing 24$ (90B5)</td> </tr> <tr> <td>FA52 FC62 FC72 FC83</td> <td></td> </tr> <tr> <td>-2 → $\varnothing 19$ (80B5)</td> <td></td> </tr> <tr> <td>-3 → $\varnothing 24$ (90B5)</td> <td></td> </tr> <tr> <td>-4 → $\varnothing 28$ (100B5)</td> <td></td> </tr> </table> <p>→ STANDARD</p>	B5	B14	-A =56 ($\varnothing 120$)	-O =56 ($\varnothing 80$)	-B =63 ($\varnothing 140$)	-P =63 ($\varnothing 90$)	-C =71 ($\varnothing 160$)	-Q =71 ($\varnothing 105$)	-D =80 ($\varnothing 200$)	-R =80 ($\varnothing 120$)	-E =90 ($\varnothing 200$)	-T =90 ($\varnothing 140$)	-F =100+112 ($\varnothing 250$)	-U =100+112 ($\varnothing 160$)	-G =132 ($\varnothing 300$)	-V =132 ($\varnothing 200$)	-H =160 ($\varnothing 350$)		-I =180 ($\varnothing 350$)		FA43 FS20 FS50	FA42 FA53 FC63 FC73	-1 → $\varnothing 14$	-2 → $\varnothing 19$	FA52 FC62 FC72 FC83	FC82	-3 → $\varnothing 24$	-4 → $\varnothing 28$	FA43 FS20 FS50	FA42 FA53 FC63 FC73	-Z → $\varnothing 9$ (56B5)	-1 → $\varnothing 14$ (71B5)	-0 → $\varnothing 11$ (63B5)	-2 → $\varnothing 19$ (80B5)	-1 → $\varnothing 14$ (71B5)	-3 → $\varnothing 24$ (90B5)	FA52 FC62 FC72 FC83		-2 → $\varnothing 19$ (80B5)		-3 → $\varnothing 24$ (90B5)		-4 → $\varnothing 28$ (100B5)		<p>B</p>  <p>A</p>  <p>B STANDARD</p>  <p>C</p>  <p>D</p>	<p>H1</p>  <p>H1 STANDARD</p>  <p>H4</p>  <p>H3</p>  <p>H2</p>  <p>H5</p>  <p>H6 Specify only for vertical positions Specificare solo per posizione verticale</p>
B5	B14																																																
-A =56 ($\varnothing 120$)	-O =56 ($\varnothing 80$)																																																
-B =63 ($\varnothing 140$)	-P =63 ($\varnothing 90$)																																																
-C =71 ($\varnothing 160$)	-Q =71 ($\varnothing 105$)																																																
-D =80 ($\varnothing 200$)	-R =80 ($\varnothing 120$)																																																
-E =90 ($\varnothing 200$)	-T =90 ($\varnothing 140$)																																																
-F =100+112 ($\varnothing 250$)	-U =100+112 ($\varnothing 160$)																																																
-G =132 ($\varnothing 300$)	-V =132 ($\varnothing 200$)																																																
-H =160 ($\varnothing 350$)																																																	
-I =180 ($\varnothing 350$)																																																	
FA43 FS20 FS50	FA42 FA53 FC63 FC73																																																
-1 → $\varnothing 14$	-2 → $\varnothing 19$																																																
FA52 FC62 FC72 FC83	FC82																																																
-3 → $\varnothing 24$	-4 → $\varnothing 28$																																																
FA43 FS20 FS50	FA42 FA53 FC63 FC73																																																
-Z → $\varnothing 9$ (56B5)	-1 → $\varnothing 14$ (71B5)																																																
-0 → $\varnothing 11$ (63B5)	-2 → $\varnothing 19$ (80B5)																																																
-1 → $\varnothing 14$ (71B5)	-3 → $\varnothing 24$ (90B5)																																																
FA52 FC62 FC72 FC83																																																	
-2 → $\varnothing 19$ (80B5)																																																	
-3 → $\varnothing 24$ (90B5)																																																	
-4 → $\varnothing 28$ (100B5)																																																	

POTENZA RICHIESTA / REQUIRED POWER / ERFORDERLICHE LEISTUNG / PUISSANCE NECESSAIRE / POTENCIA NECESARIA

Lifting / sollevamento / hubantriebe / levage / elevación

$$P \text{ [KW]} = \frac{M \text{ [Kg]} \cdot g \text{ [9.81]} \cdot v \text{ [m / s]}}{1000}$$

Rotation / rotazione / drehung / rotation / rotacion

$$P \text{ [KW]} = \frac{M \text{ [Nm]} \cdot n \text{ [rpm]}}{9550}$$

Linear movement / traslazione / linearbewegung / translation / translacion

$$P \text{ [KW]} = \frac{F \text{ [N]} \cdot v \text{ [m / s]}}{1000}$$

TORQUE / COPPIA / DREHMOMENT / COUPLE / PAR

$$M \text{ [Nm]} = \frac{9550 \cdot P \text{ [KW]}}{n \text{ [rpm]}}$$

$$M \text{ [lb in]} = \frac{63030 \cdot P \text{ [HP]}}{n \text{ [rpm]}}$$

RADIAL LOADS / CARICHI RADIALI / RADIALE - UND AXIALLASTEN / CHARGES RADIALES / CARGA RADIAL Y AXIAL

- Radial load generated by external transmissions keyed onto input and/or output shafts.
- Forza radiale generata da organi di trasmissione calettati sugli alberi di ingresso e/o uscita.
- Belastungen der Antriebs- bzw. Abtriebswellen durch von aussen eingebrachte Radiallasten.
- Charge radiale générée par la transmissions calés sur les entrées et / ou des arbres de sortie
- Cargas radiales, generada por transmisiones externas, aplicadas sobre los ejes de entrada y/o salida

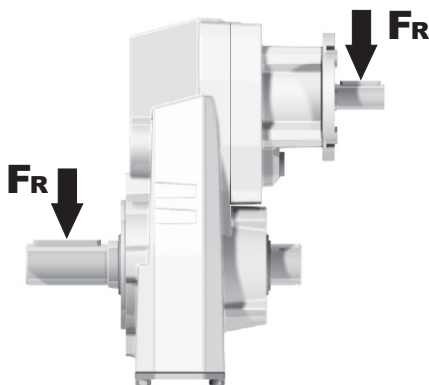

$$F_R \text{ [N]} = \frac{M \text{ [Nm]} \cdot 2000}{d \text{ [mm]}} \cdot f_k$$

$$F_R \text{ [N]} = \frac{M \text{ [lb in]} \cdot 8.9}{d \text{ [in]}} \cdot f_k$$

M	Momento torcente / Output torque / Abtriebsdrehmoment / Couple / Par torsion
d	Diametro primitivo / Diam. of driving element / Durchmesser der Abtriebseinheit / Diamètre primitif / Diámetro primitivo
f_k	Coefficiente di trasformazione / Factor / Faktor / Coefficient de transmission / Coeficiente de transmisión 1.15 Ingranaggi / Gearwheels / Zahnrad / Engrenage / Engranaje 1.25 Catena / Chain sprochets / Antriebskette / Chaîne / Cadena 1.75 Cinghia Trapezoidale / Narrow v-belt pulley / Keilriemen / Courroie trap. / Correa trapezoidal 2.50 Cinghia piatta / Flat-belt pulley / Flachzahnriem. / Courroie crantée / Correa plana

- If your application requires higher radial loads, contact our technical office. Higher load may be possible.
- Nel caso la vostra applicazione richieda carichi radiali superiori consultare il nostro ufficio tecnico, valori maggiori possono essere accettati.
- Wenn Ihre Anwendung höhere Radialbelastungen erfordert, so wenden Sie sich bitte an unser technischen Büro.
- Si votre application demande des charges radiales supérieures, s'adresser à notre bureau technique.
- En el caso en que una aplicación exija una carga radial superior a la especificada en el catálogo, consultar a nuestra oficinas técnica.

How to select a gearbox / Come selezionare un riduttore / Wie wählt man ein Getriebe
Comment sélectionner un réducteur / Cómo seleccionar un reductor

B Output speed
Velocità in uscita
Abtriebsdrehzahl
Vitesse de sortie
Velocidad de salida

Nominal power
Potenza nominale
Max. mögliche Leistung
Poissance nominale
Potencia nominal

A Nominal torque
Momento torcente nominale
Nenn Drehmoment
Couple nominal
Par de torsión nominal

Flange code
Codice flangia
Flanschtype
Code bride
Código bridas

Input speed
Velocità in entrata
Eintriebsdrehzahl
Vitesse en entrée
Velocidad de entrada

Gear size
Grandezza riduttore
Getriebegröße
Taille réducteur
Tamaño reductor

Motor power
Potenza motore
Motorleistung
Puissance moteur
Potencia motor

FA42 Compact-Gear

320Nm

Rating - Aluminum
SHAFT MOUNTED HELICAL

QUICK SELECTION / Selezione veloce										input speed (n ₁) = 1400 min ⁻¹							
Output Speed n ₂ [min ⁻¹]	Ratio i	Motor power P _{1M} [kW]	Output torque M _{2M} [Nm]	Service factor f.s.	Nominal power P _{1R} [kW]	Nominal torque M _{2R} [Nm]	Available B5 motor flanges					Available B14 motor flanges				Output Shaft 	Ratios code
							B	C	D	E	F	Q	R	T	U		
167	8.38	4	215	1.0	4.1	225	B					C	C			2821	01
139	10.04	3	194	1.2	3.7	240	B					C	C			2818	02
114	12.33	3	238	1.1	3.2	260	B					C	C			2813	03
92	15.16	2.2	216	1.2	2.6	260	B					C	C			1921	04

C Ratio
Rapporto
Untersetzung
Rapport de réduction
Relación

Transmitted torque
Momento torcente trasmesso
Mögliche Drehmomente
Couple de sortie
Par transmitido

Service factor
Fattore di servizio
Betriebsfaktor
Facteur de service
Factor de servicio

Output shaft diam.
Diam. albero uscita
Durchmesser abtriebswelle
Diametre arbre lent
Diametro eje de salida

Notes
Note
Anmerkungen
Note
Notas

Type of load and starts per hour Tipo di carico e avviamenti per ora		Oper. hours per day Ore di funz. giorn.		
		3 h	10 h	24 h
Continuous or intermittent appl. with start / hour Applicazione cont. o interm. con n.ro operazioni/ora	Uniform / Uniforme	0.8	1	1.25
	Moderate / Moderato	1	1.25	1.5
	Heavy / Forte	1.25	1.5	1.75
Intermittent application with start / hour Applicazione intermittente con n.ro operazioni/ora	Uniform / Uniforme	1	1.25	1.5
	Moderate / Moderato	1.25	1.5	1.75
	Heavy / Forte	1.5	1.75	2.15

D Motor flange available Flange disponibili Erhältliche Motorflansche Brides disponibles Bridas disponibles	
B) Mounting with reduction ring Montaggio con boccia di riduzione Reduzierhülsen Montage avec douille de réduction Montaje con casquillo de reducción	
C) Motor flangeholes position/terminal box position Posizione fori flangia/basetta motore Bohrungsposition am Motorflansch/-sockel Position trous bride/barrette à bornes moteur Posición agujeros brida / base motor	
B) Available without reduction bushes Disponibile anche senza boccia Auch ohne Reduzierbuchse verfügbar Disponible aussi sans douille de réduction Disponible tambien sin casquillo	

A	Select required torque (according to service factor)	Seleziona la coppia desiderata (comprensiva del fattore di servizio)	Max. Drehmoment in Bezug zum Betriebsfaktor	Sélectionner le couple souhaité (comprenant le facteur de service)	Seleccionar el par deseado (incluyendo el factor de servicio)
B	Select output speed	Seleziona la velocità in uscita	Ausgewählte Abtriebsdrehzahl	Sélectionner la vitesse de sortie	Seleccionar la velocidad de salida
C	On the same line of selected geared motor, you can find the gear ratio	Sulla riga corrispondente alla motorizzazione prescelta si può rilevare il rapporto di riduzione	Auf der gleichen Linie wie die ausgewählte Motorleistung steht auch die Getriebeuntersetzung	Sur la ligne correspondante à la motorisation pré-choisie on peut relever le rapport de réduction	En la línea correspondiente al motor preseleccionado es posible encontrar la relación de reducción
D	Select motor flange available (if requested)	Scegli la flangia disponibile (se richiesta)	Erhältliche Motorflansche (auf Anfrage)	Choisir la bride disponible (si elle est demandée)	Seleccionar la brida disponible (sobre pedido)



QUICK SELECTION / Selezione veloce

input speed (n_1) = 1400 min⁻¹

Output Speed n_2 [min ⁻¹]	Ratio i	Motor power P_{1M} [kW]	Output torque M_{2M} [Nm]	Service factor f.s.	Nominal power P_{1R} [kW]	Nominal torque M_{2R} [Nm]	Available B5 motor flanges		Available B14 motor flanges			Hollow Shaft standard ø20	Ratios code
							B	C	O	P	Q		
24.2	57.95	0.25	93	1.0	0.24	90			C	C		2844	01
13.4	104.80	0.12	83	1.1	0.13	90			C	C		1954	02
11.5	121.47	0.12	96	0.9	0.12	90			C	C		1756	03
9.8	142.59	0.09	90	1.0	0.10	90			C	C		1558	04
8.2	170.20	0.06	70	1.3	0.08	90			C	C		1360	05
6.0	232.32	0.06	96	0.9	0.06	90			C	C		1063	06
4.6	303.20	0.06	126	*	0.05	90			C	C		974	07
3.5	400.37	0.06	166	*	0.04	90			C	C		776	08

The dynamic efficiency is **0.93** for all ratios

A) Motor Flanges Available Flange Motore Disponibili
 B) Supplied with Reduction Bushing Fornito con Bussola di Riduzione
 B) Available on Request without reduction bushing Disponibile a Richiesta senza Bussola di Riduzione
 C) Motor Flange Holes Position Posizione Fori Flangia Motore

* Power higher than the maximum one which can be born by the gearbox. Select according to the torque moment M_{2R}
 Potenza superiore a quella massima sopportabile dal riduttore. Selezionare in base al momento torcente M_{2R} .

EN Unit **FS20** is supplied with synthetic oil for lifetime lubrication, no maintenance is necessary. See table 1 for lubrication and recommended quantity. In table 2 please see possible radial loads and axial loads on the gearbox.

I Il riduttore **FS20** viene fornito completo di olio sintetico per la lubrificazione permanente e non necessita di alcuna manutenzione. Vedi tab.1 per oli e quantità consigliati. In tab.2 sono presenti i carichi radiali e assiali applicabili al riduttore.

D Das Getriebe **FS20** ist mit synthetischem Öl gefüllt und ist lebensdauergeschmiert. In Tabelle 1 ist die Schmiermenge und das empfohlene Schmiermittel angegeben. In Tabelle 2 sind die zulässigen Radial- und Axialbelastungen des Getriebes aufgeführt.

F Le réducteur **FS20** est fourni complet avec de l'huile synthétique pour la lubrification permanente et ne nécessite aucun entretien. Voir tableau 1 concernant les huiles et les quantités conseillées. Les charges radiales et axiales applicables au réducteur sont précisées dans le tableau 2.

E El reductor tamaño **FS20** se suministra, lubricado de por vida con aceite sintético y no requieren mantenimiento alguna. Ver tabla 1, para cantidades y aceites recomendados. En la tabla 2, se encuentran las cargas radiales y axiales admitidas por el reductor.

LUBRICATION FS20 Oil Quantity 0.50 Lt.

AGIP Telium VSF 320 **SHELL** Omala S4 WE 320

For all details on lubrication and plugs check our website tab. 1
 Per maggiori dettagli su lubrificazione e tappi olio vedi il nostro sito web

RADIAL LOADS

Input shaft
Albero in entrata

n_1	FA	FR
1400	140	700
900	160	800

***Strong axial loads in the DX direction are not allowed.**
 Non sono consentiti forti carichi assiali con direzione DX

tab. 2

PFS20... Basic gearbox
Riduttore base

Gearbox weight
peso riduttore **4.3 kg**

RFS20... Input Shaft
Albero in entrata

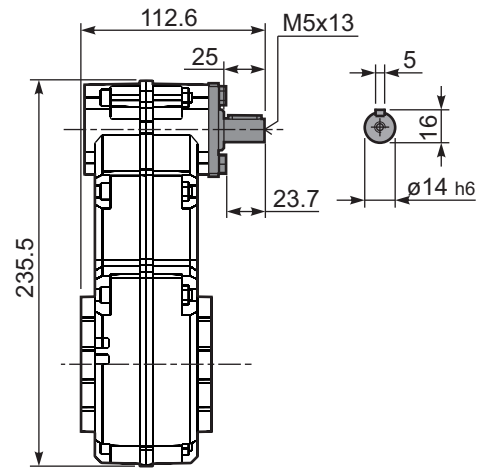
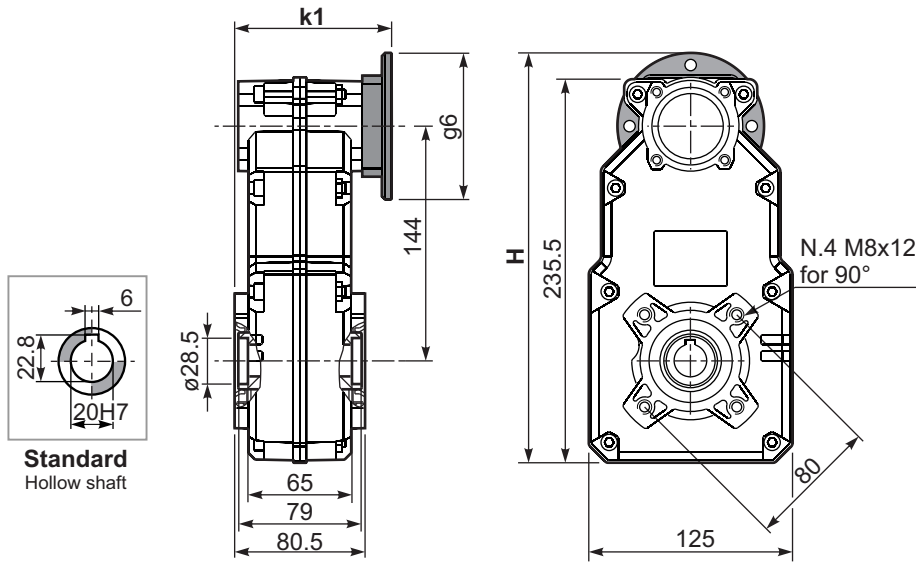

B14 Motor Flanges	H	g6	k1	kit code
56 B14	245.5	80	94.3	KC40.4.049
63 B14	251.5	90	96.8	K050.4.047
71 B14	259	105	94.3	K050.4.045

B5 Motor Flanges	H	g6	k1	kit code
63 B5	276.5	138	96.8	K050.4.041
71 B5	286.5	160	94.3	K050.4.042

PFS20-F Output flange
flangia di uscita

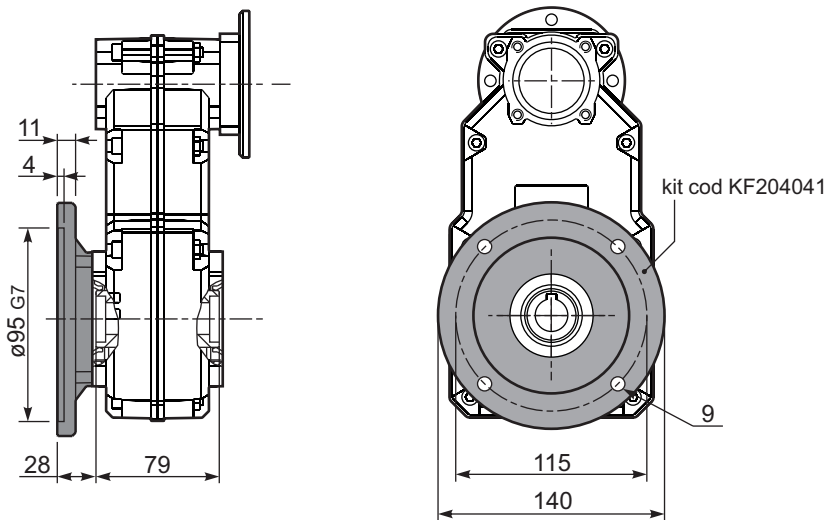



QUICK SELECTION / Selezione veloce input speed (n_1) = 1400 min⁻¹

Output Speed n_2 [min ⁻¹]	Ratio i	Motor power P_{1M} [kW]	Output torque M_{2M} [Nm]	Service factor f.s.	Nominal power P_{1R} [kW]	Nominal torque M_{2R} [Nm]	Available B5 motor flanges			Available B14 motor flanges			Output Shaft 	Ratios code	
							D	E	F	R	T	U			
							80	90	100 112	80	90	100 112			
481	2.91	4	76	1.8	7.2	140	B	B		B	B		3499	standard	01
373	3.75	4	98	1.6	6.4	160	B	B		B	B		28105	ø30	02
263	5.33	4	140	1.2	4.8	170	B	B		B	B		21112		03
219	6.39	4	167	1.0	4.0	170	B	B		B	B		18115	ø35	04
178	7.85	4	205	1.1	4.3	225	B	B		B	B		13102	On request	05

The dynamic efficiency is **0.98** for all ratios

Motor Flanges Available Flange Motore Disponibili
 B) Supplied with Reduction Bushing Fornito con Bussola di Riduzione
 B) Available on Request without reduction bushing Disponibile a Richiesta senza Bussola di Riduzione
 C) Motor Flange Holes Position Posizione Fori Flangia Motore

EN Unit **FA41** is supplied with synthetic oil for lifetime lubrication, no maintenance is necessary. See table 1 for lubrication and recommended quantity. In table 2 please see possible radial loads and axial loads on the gearbox.

I Il riduttore **FA41** viene fornito completo di olio sintetico per la lubrificazione permanente e non necessita di alcuna manutenzione. Vedi tab.1 per oli e quantità consigliati. In tab.2 sono presenti i carichi radiali e assiali applicabili al riduttore.

D Das Getriebe **FA41** ist mit synthetischem Öl gefüllt und ist lebensdauergeschmiert. In Tabelle 1 ist die Schmiermenge und das empfohlene Schmiermittel angegeben. In Tabelle 2 sind die zulässigen Radial- und Axialbelastungen des Getriebes aufgeführt.

F Le réducteur **FA41** est fourni complet avec de l'huile synthétique pour la lubrification permanente et ne nécessite aucun entretien. Voir tableau 1 concernant les huiles et les quantités conseillées. Les charges radiales et axiales applicables au réducteur sont précisées dans le tableau 2.

E El reductor tamaño **FA41** se suministra, lubricado de por vida con aceite sintético y no requieren mantenimiento alguna. Ver tabla 1, para cantidades y aceites recomendados. En la tabla 2, se encuentran las cargas radiales y axiales admitidas por el reductor.

Standard supplied	For these mounting position specify in the order or add oil Per queste posizioni specificare in fase d'ordine o aggiungere olio				
1.10 LT	0.65 LT	0.65 LT	0.65 LT	1.15 LT	0.80 LT
AGIP Telium VSF 320			SHELL Omala S4 WE 320		

For all details on lubrication and plugs check our website tab. 1
Per maggiori dettagli su lubrificazione e tappi olio vedi il nostro sito web

RADIAL AND AXIAL LOADS

Output shaft
Albero di uscita

$F_R (N)$
 $F_A (N)$

$F_{eq} = F_R \cdot \frac{127.5}{X+97.5}$
 $F_{eq} (N)$

n_2 [min ⁻¹]	FA	FR	n_2 [min ⁻¹]	FA	FR	n_2 [min ⁻¹]	FA	FR
300	300	1500	140	390	1950	70	490	2450
250	320	1600	120	410	2050	40	590	2950
200	350	1750	85	460	2300	15	800	4000

On request reinforced bearings to increase loads.
A richiesta cuscinetti rinforzati per aumentare i carichi.

tab. 2



QUICK SELECTION / Selezione veloce input speed (n₁) = 1400 min⁻¹

Output Speed n ₂ [min ⁻¹]	Ratio i	Motor power P _{1M} [kW]	Output torque M _{2M} [Nm]	Service factor f.s.	Nominal power P _{1R} [kW]	Nominal torque M _{2R} [Nm]	Available B5 motor flanges					Available B14 motor flanges				Output Shaft 	Ratios code
							B	C	D	E	F	Q	R	T	U		
							63	71	80	90	100	112	71	80	90		
167	8.38	4	215	1.0	4.1	225	B					C	C			2821	01
139	10.04	3	194	1.2	3.7	240	B					C	C			2818	02
114	12.33	3	238	1.1	3.2	260	B					C	C			2813	03
92	15.16	2.2	215	1.2	2.6	260	B					C	C			1921	04
80	17.57	2.2	250	1.1	2.3	270	B					C	C			1721	05
77	18.16	2.2	258	1.1	2.4	290	B					C	C			1918	06
67	21.05	2.2	299	1.1	2.3	320	B					C	C			1718	07
63	22.30	2.2	317	1.0	2.2	320	B					C	C			1913	08
57	24.70	2.2	351	0.9	2.0	320	B					C	C			1518	09
54	25.85	2.2	367	0.9	1.9	320	B					C	C			1713	10
47.5	29.49	1.5	289	1.1	1.7	320	B					C	C			1318	11
46.1	30.34	1.5	297	1.1	1.6	320	B					C	C			1513	12
41.7	33.60	1.1	240	1.0	1.1	250	B					C	C			1021	13
38.7	36.21	1.1	259	1.2	1.3	320	B					C	C			1313	14
34.8	40.25	1.1	288	1.0	1.1	300	B					C	C			1018	15
28.3	49.43	1.1	354	0.9	0.99	320	B					C	C			1013	16
26.7	52.53	0.75	258	1.0	0.76	260	B					C	C			918	17
21.7	64.51	0.75	317	1.0	0.75	315	B					C	C			913	18
20.2	69.37	0.37	168	1.1	0.42	190	B					C	C			718	19
16.4	85.19	0.37	206	1.1	0.41	230	B					C	C			713	20

The dynamic efficiency is **0.96** for all ratios

Motor Flanges Available Flange Motore Disponibili
 B) Supplied with Reduction Bushing Fornito con Bussola di Riduzione
 B) Available on Request without reduction bushing Disponibile a Richiesta senza Bussola di Riduzione
 C) Motor Flange Holes Position Posizione Fori Flangia Motore

EN Unit **FA42** is supplied with synthetic oil for lifetime lubrication, no maintenance is necessary. See table 1 for lubrication and recommended quantity. In table 2 please see possible radial loads and axial loads on the gearbox.

I Il riduttore **FA42** viene fornito completo di olio sintetico per la lubrificazione permanente e non necessita di alcuna manutenzione. Vedi tab.1 per oli e quantità consigliati. In tab.2 sono presenti i carichi radiali e assiali applicabili al riduttore.

D Das Getriebe **FA42** ist mit synthetischem Öl gefüllt und ist lebensdauergeschmiert. In Tabelle 1 ist die Schmiermenge und das empfohlene Schmiermittel angegeben. In Tabelle 2 sind die zulässigen Radial- und Axialbelastungen des Getriebes aufgeführt.

F Le réducteur **FA42** est fourni complet avec de l'huile synthétique pour la lubrification permanente et ne nécessite aucun entretien. Voir tableau 1 concernant les huiles et les quantités conseillées. Les charges radiales et axiales applicables au réducteur sont précisées dans le tableau 2.

E El reductor tamaño **FA42** se suministra, lubricado de por vida con aceite sintético y no requieren mantenimiento alguna. Ver tabla 1, para cantidades y aceites recomendados. En la tabla 2, se encuentran las cargas radiales y axiales admitidas por el reductor.

Standard supplied	For these mounting position specify in the order or add oil Per queste posizioni specificare in fase d'ordine o aggiungere olio				
H1	H4	H3	H2	H5	H6
1.15 LT	0.70 LT	0.70 LT	0.70 LT	1.20 LT	0.8 LT
AGIP Telium VSF 320			SHELL Omala S4 WE 320		

For all details on lubrication and plugs check our website tab. 1
Per maggiori dettagli su lubrificazione e tappi olio vedi il nostro sito web

RADIAL AND AXIAL LOADS

Output shaft
Albero di uscita

$F_{eq} = FR \cdot \frac{127.5}{X+97.5}$

n ₂ [min ⁻¹]	FA	FR	n ₂ [min ⁻¹]	FA	FR	n ₂ [min ⁻¹]	FA	FR
300	300	1500	140	390	1950	70	490	2450
250	320	1600	120	410	2050	40	590	2950
200	350	1750	85	460	2300	15	800	4000

On request reinforced bearings to increase loads.
A richiesta cuscinetti rinforzati per aumentare i carichi.

Input shaft
Albero in entrata

n ₁	FA	FR
1400	240	1200
900	280	1400
500	340	1700

tab. 2

PFA42C...

Basic gearbox
Riduttore base

Gearbox weight
peso riduttore **9.0 kg**

M. flanges	Kit code	øF	A
63B5	K063.4.041	140	169.5
71B5	K063.4.042	160	167.5
80/90B5	K063.4.043	200	169.5
100/112B5	KC40.4.043	250	184.5
71B14	K063.4.047	105	167.5
80B14	K063.4.046	120	169.5
90B14	K063.4.041	140	169.5
100/112B14	KC40.4.041	160	184.5

● Available torque arms,
see our web site
Bracci di reazione disponibili,
consulta il nostro sito web

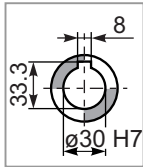

Standard
Hollow shaft

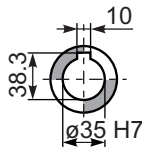

On request
A richiesta

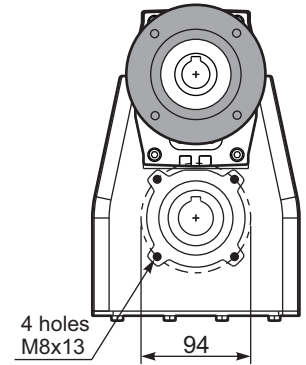
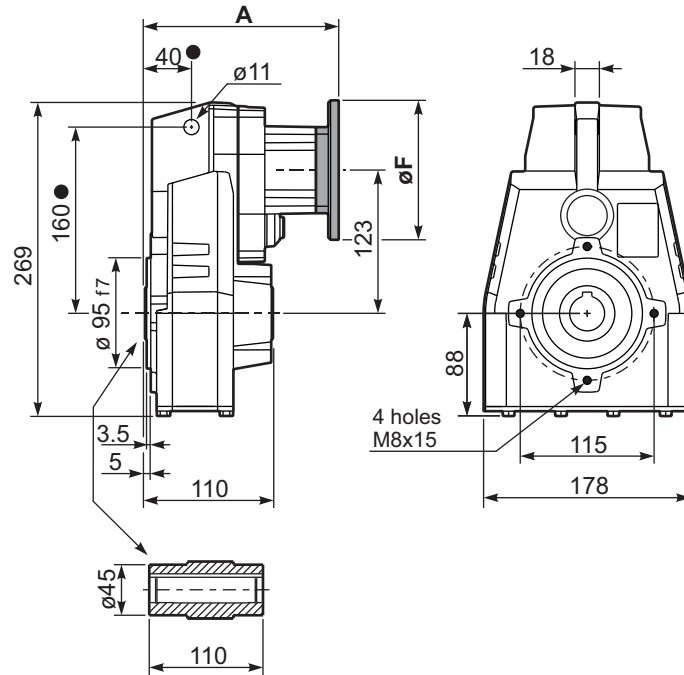

PFA42...-F...

Output flange
Flangia uscita

Motor Flange	k1
63B5	205.5
71B5	203.5
80/90B5	205.5
100/112B5	221
71B14	203.5
80B14	204.5
90B14	205.5
100/112B14	221

Available output flanges
Flange di uscita

a1 ø	b1	c1	e1	f1	s1	Kit code
160	110	10	130	3	9	KX5A.9.010
200	130	13	165	3.5	11	KX5A.9.011
250	180	14	215	4	14	KX5A.9.012

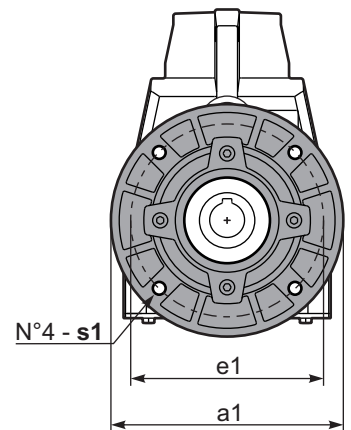
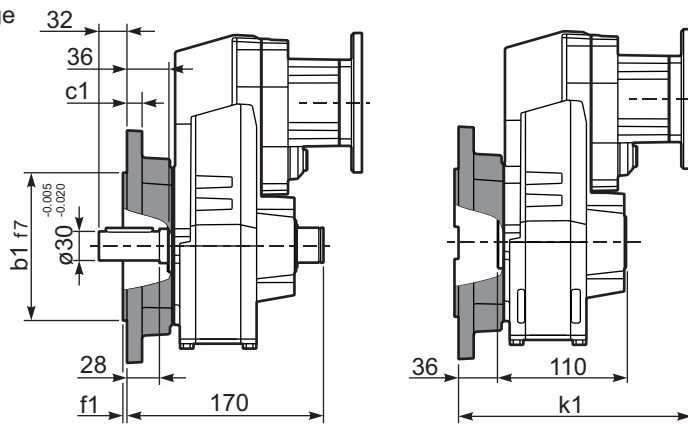

RFA42C...

Input Shaft
Albero in entrata

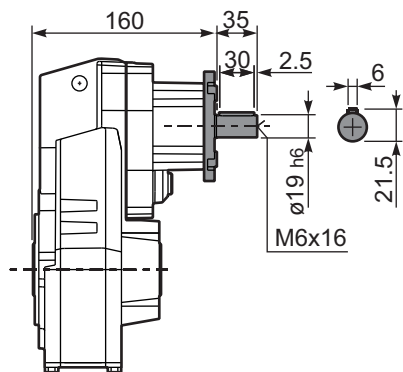

PFA42 A...

Single output shaft
Albero uscita semplice

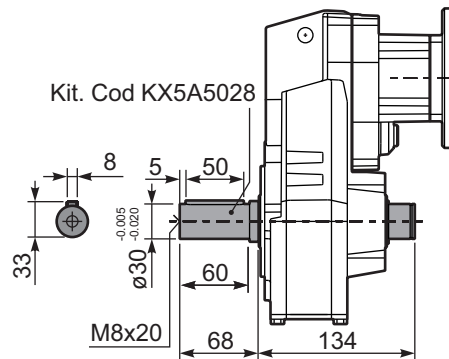

PFA42D...

Shrink disk
Calettatore

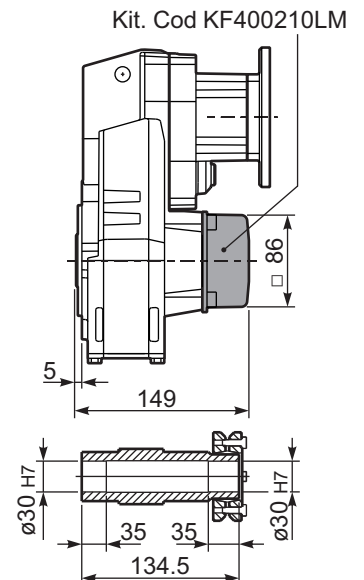



QUICK SELECTION / Selezione veloce

input speed (n_1) = 1400 min⁻¹

Output Speed n_2 [min ⁻¹]	Ratio i	Motor power P_{1M} [kW]	Output torque M_{2M} [Nm]	Service factor f.s.	Nominal power P_{1R} [kW]	Nominal torque M_{2R} [Nm]	Available B5 motor flanges		Available B14 motor flanges			Output Shaft 	Ratios code
							B	C	O	P	Q		
							63	71	56	63	71		
18.8	74.33	0.37	176	1.8	0.67	320			C	C		191313	01
17.0	82.56	0.37	196	1.6	0.60	320			C	C		151318	02
16.0	87.48	0.37	207	1.5	0.57	320			C	C		131713	03
13.8	101.40	0.37	240	1.3	0.49	320			C	C		151313	04
11.4	122.57	0.37	291	1.1	0.41	320			C	C		131313	05
10.1	138.59	0.37	329	1.0	0.36	320			C	C		101318	06
8.7	160.82	0.25	257	1.2	0.31	320			C	C		91713	07
8.2	170.20	0.25	272	1.2	0.29	320			C	C		101313	08
7.6	183.48	0.25	294	1.1	0.27	320			C	C		91318	09
6.5	214.15	0.18	262	1.2	0.23	320			C	C		71713	10
6.2	225.33	0.18	276	1.2	0.22	320			C	C		91313	11
5.7	244.32	0.18	299	1.1	0.20	320			C	C		71318	12
5.5	254.15	0.18	311	1.0	0.20	320			C	C		61713	13
4.8	289.96	0.18	355	0.9	0.17	320			C	C		61318	14
4.7	300.05	0.18	367	0.9	0.17	320			C	C		71313	15
3.9	356.09	0.12	282	1.1	0.14	320			C	C		61313	16

The dynamic efficiency is **0.94** for all ratios

- Motor Flanges Available** Flange Motore Disponibili
- B) Supplied with Reduction Bushing** Fornito con Bussola di Riduzione
- B) Available on Request without reduction bushing** Disponibile a Richiesta senza Bussola di Riduzione
- C) Motor Flange Holes Position** Posizione Fori Flangia Motore

EN Unit **FA43** is supplied with synthetic oil for lifetime lubrication, no maintenance is necessary. See table 1 for lubrication and recommended quantity. In table 2 please see possible radial loads and axial loads on the gearbox.

I Il riduttore **FA43** viene fornito completo di olio sintetico per la lubrificazione permanente e non necessita di alcuna manutenzione. Vedi tab.1 per oli e quantità consigliati. In tab.2 sono presenti i carichi radiali e assiali applicabili al riduttore.

D Das Getriebe **FA43** ist mit synthetischem Öl gefüllt und ist lebensdauergeschmiert. In Tabelle 1 ist die Schmiermenge und das empfohlene Schmiermittel angegeben. In Tabelle 2 sind die zulässigen Radial- und Axialbelastungen des Getriebes aufgeführt.

F Le réducteur **FA43** est fourni complet avec de l'huile synthétique pour la lubrification permanente et ne nécessite aucun entretien. Voir tableau 1 concernant les huiles et les quantités conseillées. Les charges radiales et axiales applicables au réducteur sont précisées dans le tableau 2.

E El reductor tamaño **FA43** se suministra, lubricado de por vida con aceite sintético y no requieren mantenimiento alguna. Ver tabla 1, para cantidades y aceites recomendados. En la tabla 2, se encuentran las cargas radiales y axiales admitidas por el reductor.

Standard supplied	For these mounting position specify in the order or add oil Per queste posizioni specificare in fase d'ordine o aggiungere olio				
H1	H4	H3	H2	H5	H6
1.30 LT	0.70 LT	0.70 LT	0.70 LT	1.35 LT	0.90 LT
AGIP Telium VSF 320			SHELL Omala S4 WE 320		

For all details on lubrication and plugs check our website **tab. 1**
Per maggiori dettagli su lubrificazione e tappi olio vedi il nostro sito web

RADIAL AND AXIAL LOADS



n_2 [min ⁻¹]	FA	FR	n_2 [min ⁻¹]	FA	FR	n_2 [min ⁻¹]	FA	FR
300	300	1500	140	390	1950	70	490	2450
250	320	1600	120	410	2050	40	590	2950
200	350	1750	85	460	2300	15	800	4000

On request reinforced bearings to increase loads.
A richiesta cuscinetti rinforzati per aumentare i carichi.

n_1	FA	FR
1400	140	700
900	160	800
500	190	950

tab. 2

PFA43C... Basic gearbox
Riduttore base

Gearbox weight
peso riduttore **8.9 kg**

M. flanges	Kit code	øF	A
63B5	K050.4.041	138	175
71B5	K050.4.042	160	172.5
56B14	KC40.4.049	80	172.5
63B14	K050.4.047	90	175
71B14	K050.4.045	105	172.5

● Available torque arms,
see our web site
Bracci di reazione disponibili,
consulta il nostro sito web

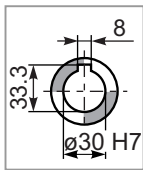

Standard
Hollow shaft

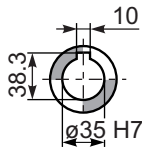

On request
A richiesta

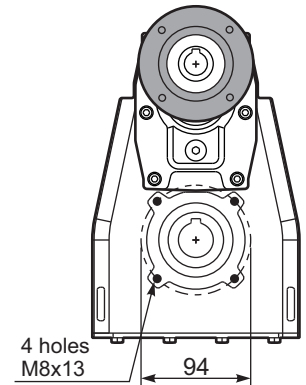
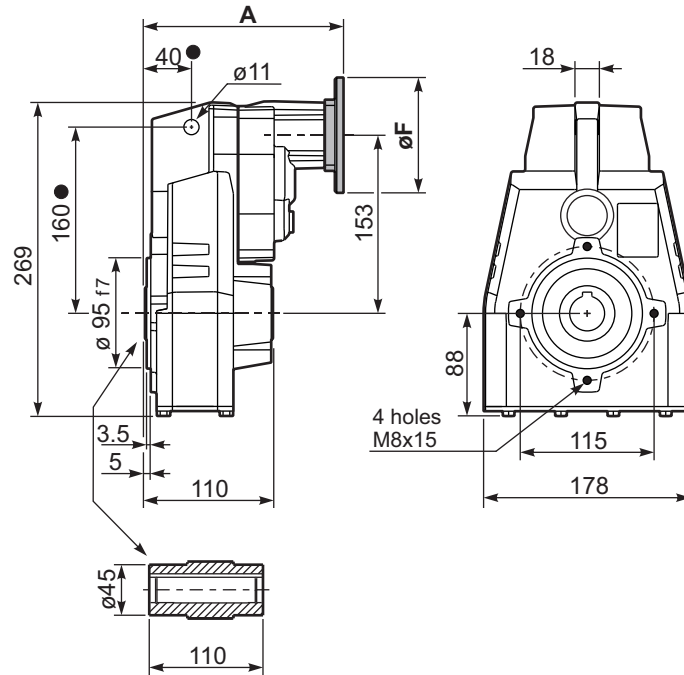

PFA43...-F... Output flange
Flangia uscita

Motor Flange	k1
63B5	209
71B5	207
56B14	208.5
63B14	211
71B14	208.5

Available output flanges
Flange di uscita

a1 ø	b1	c1	e1	f1	s1	Kit code
160	110	10	130	3	9	KX5A.9.010
200	130	13	165	3.5	11	KX5A.9.011
250	180	14	215	4	14	KX5A.9.012

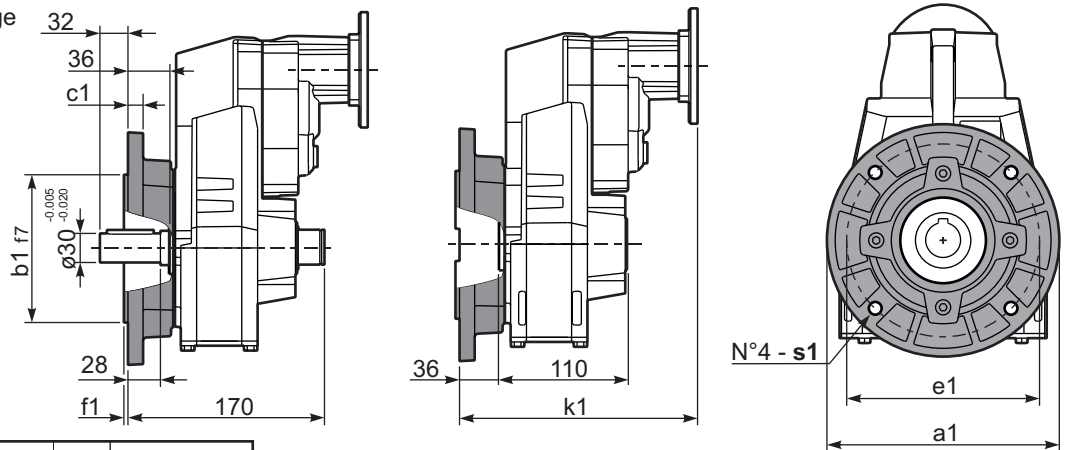

RFA43C... Input Shaft
Albero in entrata

PFA43 A... Single output shaft
Albero uscita semplice

PFA43D... Shrink disk
Calettatore

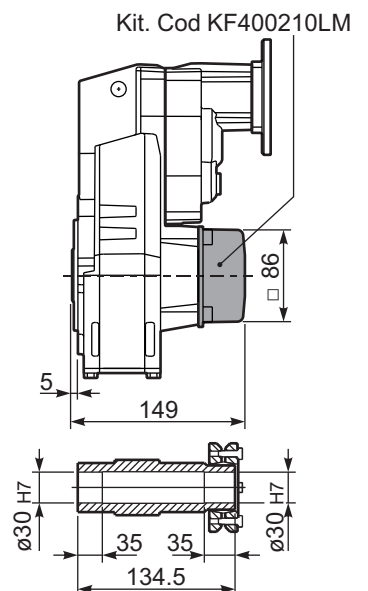
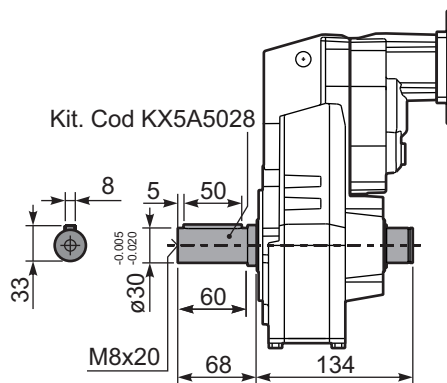
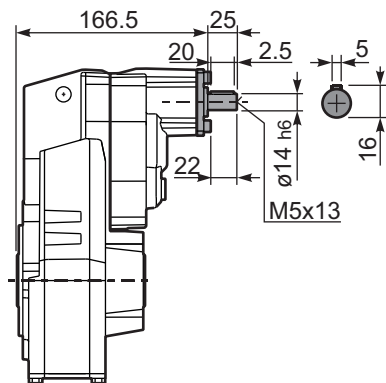



QUICK SELECTION / Selezione veloce

input speed (n_1) = 1400 min⁻¹

Output Speed n_2 [min ⁻¹]	Ratio i	Motor power P_{1M} [kW]	Output torque M_{2M} [Nm]	Service factor $f.s.$	Nominal power P_{1R} [kW]	Nominal torque M_{2R} [Nm]	Available B5 motor flanges					Available B14 motor flanges				Output Shaft 	Ratios code 	
							C	D	E	F	G	R	T	U	V			
							71	80	90	100 112	132	80	90	100 112	132			
213	6.57	5.5	230	1.2	6.5	280	B										3018	01
185	7.56	5.5	265	1.1	5.9	290	B										3016	02
159	8.82	5.5	309	1.0	5.5	320	B										3014	03
113	12.39	5.5	434	1.0	5.5	450	B										2018	04
98	14.24	5.5	499	0.9	4.8	450	B										2016	05
84	16.75	4	429	1.1	4.3	470	B										1618	06
73	19.25	4	494	1.0	3.9	490	B										1616	07
64	21.78	4	558	0.9	3.4	490	B										1318	08
56	25.04	3	483	1.0	3.0	490	B										1316	09
47.9	29.23	3	564	0.9	2.6	490	B										1314	10
45.7	30.65	2.2	436	1.1	2.4	490	B										1116	11
39.1	35.78	2.2	509	1.0	2.1	490	B										1114	12
36.3	38.55	2.2	548	0.9	1.9	490	B										818	13
31.6	44.32	1.5	434	1.1	1.7	490	B										816	14
27.1	51.74	1.5	507	1.0	1.4	490	B										814	15
22.9	61.03	1.1	437	1.1	1.2	480	B										616	16
19.6	71.25	1.1	510	1.0	1.1	490	B										614	17

The dynamic efficiency is **0.96** for all ratios

- Motor Flanges Available**
Flange Motore Disponibili
- B) Supplied with Reduction Bushing**
Fornito con Bussola di Riduzione
- B) Available on Request without reduction bushing**
Disponibile a Richiesta senza Bussola di Riduzione
- C) Motor Flange Holes Position**
Posizione Fori Flangia Motore

EN Unit **FA52** is supplied with synthetic oil for lifetime lubrication, no maintenance is necessary. See table 1 for lubrication and recommended quantity. In table 2 please see possible radial loads and axial loads on the gearbox.

I Il riduttore **FA52** viene fornito completo di olio sintetico per la lubrificazione permanente e non necessita di alcuna manutenzione. Vedi tab.1 per oli e quantità consigliati. In tab.2 sono presenti i carichi radiali e assiali applicabili al riduttore.

D Das Getriebe **FA52** ist mit synthetischem Öl gefüllt und ist lebensdauergeschmiert. In Tabelle 1 ist die Schmiermenge und das empfohlene Schmiermittel angegeben. In Tabelle 2 sind die zulässigen Radial - und Axialbelastungen des Getriebes aufgeführt.

F Le réducteur **FA52** est fourni complet avec de l'huile synthétique pour la lubrification permanente et ne nécessite aucun entretien. Voir tableau 1 concernant les huiles et les quantités conseillées. Les charges radiales et axiales applicables au réducteur sont précisées dans le tableau 2.

E El reductor tamaño **FA52** se suministra, lubricado de por vida con aceite sintético y no requieren mantenimiento alguna. Ver tabla 1, para cantidades y aceites recomendados. En la tabla 2, se encuentran las cargas radiales y axiales admitidas por el reductor.

Standard supplied	For these mounting position specify in the order or add oil Per queste posizioni specificare in fase d'ordine o aggiungere olio				
1.85 LT	1.15 LT	1.15 LT	1.30 LT	2.10 LT	1.30 LT
AGIP Telium VSF 320			SHELL Omala S4 WE 320		

For all details on lubrication and plugs check our website **tab. 1**
Per maggiori dettagli su lubrificazione e tappi olio vedi il nostro sito web

RADIAL AND AXIAL LOADS

Output shaft
Albero di uscita

Input shaft
Albero in entrata

n_2	FA	FR	n_2	FA	FR	n_2	FA	FR
300	400	2000	140	460	2300	70	580	2900
250	420	2100	120	500	2500	40	780	3900
200	440	2200	85	550	2750	15	1140	5700

On request reinforced bearings to increase loads.
A richiesta cuscinetti rinforzati per aumentare i carichi.

n_1	FA	FR
1400	400	2000
900	440	2200
500	440	2200

tab. 2

PFA52C...

Basic gearbox
Riduttore base

Gearbox weight
peso riduttore **15.5 kg**

M. flanges	Kit code	øF	A
71B5	KC023.4.041	160	227
80/90B5	KC023.4.042	200	229
100/112B5	KC023.4.043	250	238
132B5	KC50.4.043	300	256
80B14	KC085.4.046	120	229
90B14	KC085.4.045	140	229
100/112B14	KC085.4.047	160	238
132B14	KC50.4.041	200	256

● Available torque arms,
see our web site
Bracci di reazione disponibili,
consulta il nostro sito web

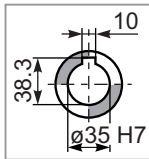

Standard
Hollow shaft

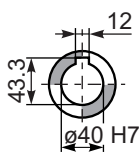

On request
A richiesta

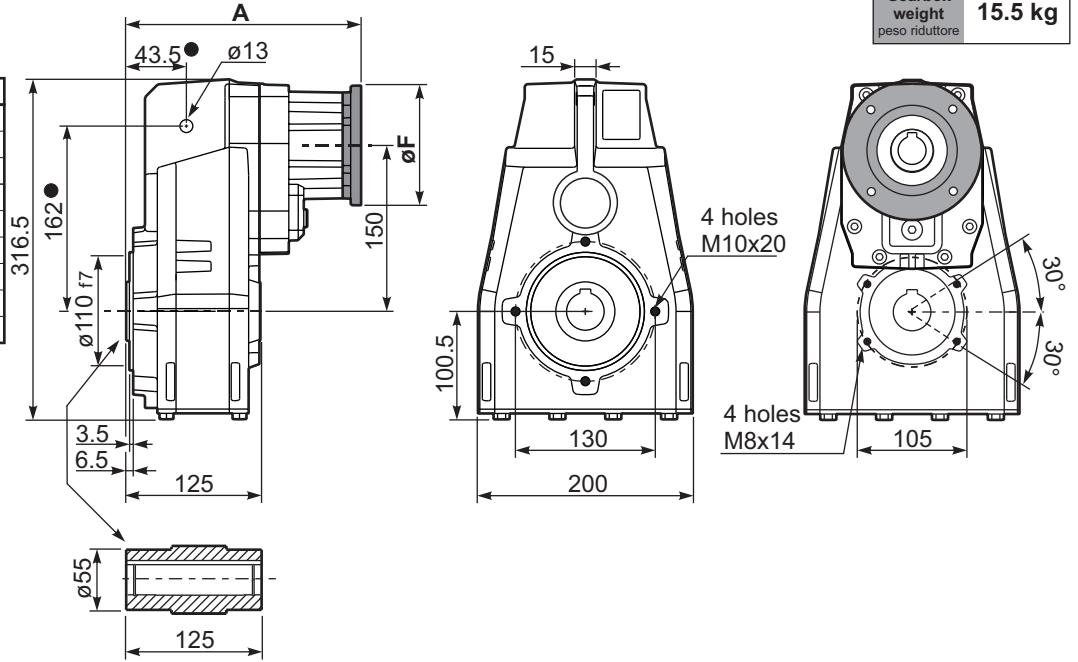

PFA52...-F...

Output flange
Flangia uscita

M. flanges	k1
71B5	260
80/90B5	262
100/112B5	268
132B5	289.5
80B14	260
90B14	260
100/112B14	271
132B14	289.5

Available output flanges
Flange di uscita

a1 ø	b1	c1	e1	s1	Kit code
250	180	13	215	14	KF60.9.011
300	230	16	265	14	KF60.9.012

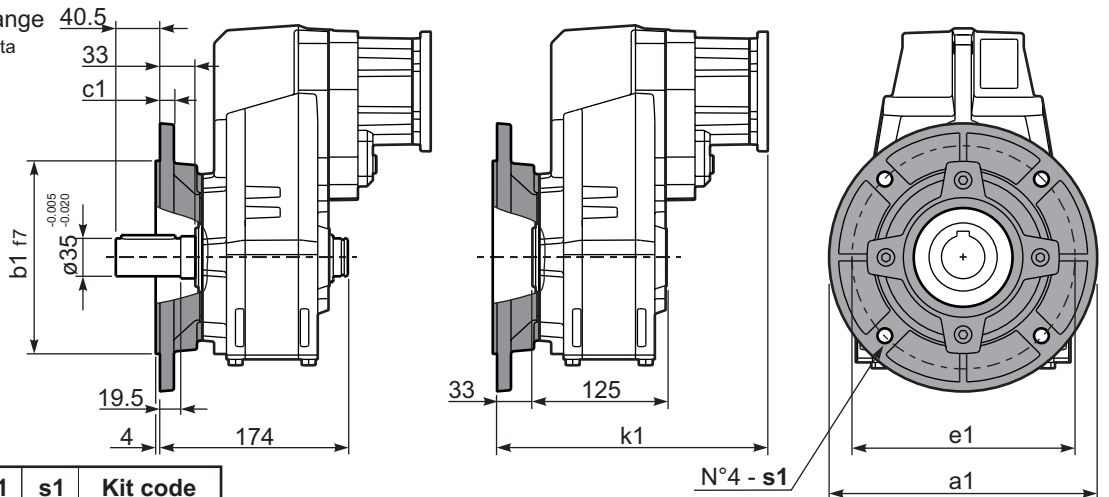

N°4 - s1

RFA52C...

Input Shaft
Albero in entrata

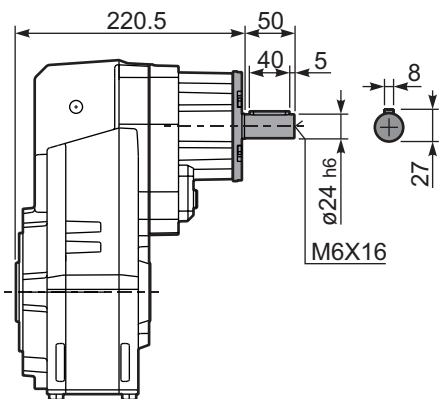

PFA52 A...

Single output shaft
Albero uscita semplice

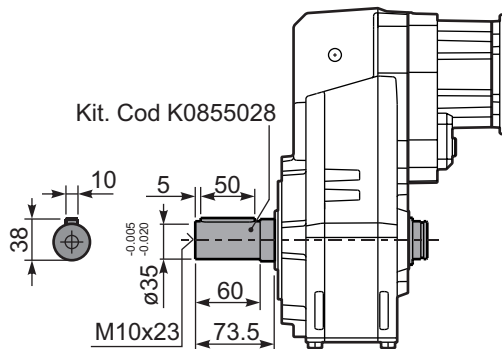

Kit. Cod K0855028

PFA52D...

Shrink disk
Calettatore

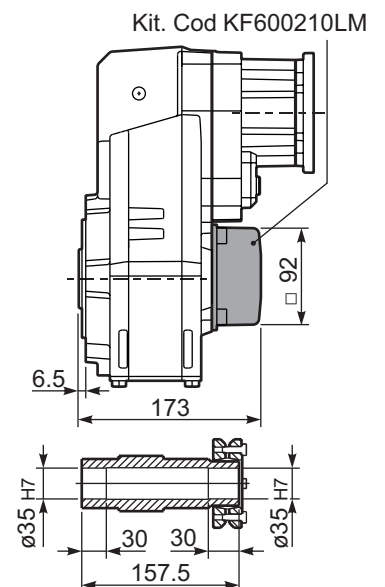

Kit. Cod KF600210LM



QUICK SELECTION / Selezione veloce

input speed (n_1) = 1400 min⁻¹

Output Speed n_2 [min ⁻¹]	Ratio i	Motor power P_{1M} [kW]	Output torque M_{2M} [Nm]	Service factor f.s.	Nominal power P_{1R} [kW]	Nominal torque M_{2R} [Nm]	Available B5 motor flanges				Available B14 motor flanges			Output Shaft 	Ratios code
							B	C	D	E	Q	R	T		
							63	71	80	90	71	80	90		
22.6	61.89	1.1	434	1.2	1.3	510	B				C	C		191318	01
19.7	71.16	1.1	499	1.0	1.1	510	B				C	C		191316	02
17.0	82.48	1.1	578	0.9	0.96	510	B				C	C		171316	03
14.5	96.29	0.75	463	1.1	0.83	510	B				C	C		171314	04
13.9	100.51	0.75	483	1.1	0.79	510	B				C	C		131318	05
12.1	115.56	0.55	410	1.2	0.69	510	B				C	C		131316	06
11.1	125.96	0.55	447	1.1	0.63	510	B				C	C		190816	07
10.4	134.91	0.55	479	1.1	0.59	510	B				C	C		131314	08
9.5	147.05	0.55	522	1.0	0.54	510	B				C	C		190814	09
8.2	170.44	0.37	404	1.3	0.47	510	B				C	C		170814	10
7.6	184.15	0.37	437	1.2	0.43	510	B				C	C		101314	11
6.8	205.87	0.37	488	1.0	0.39	510	B				C	C		91316	12
5.8	240.34	0.37	570	0.9	0.33	510	B				C	C		91314	13
5.0	279.22	0.25	447	1.1	0.28	510	B				C	C		100816	14
4.3	325.97	0.25	522	1.0	0.24	510	B				C	C		100814	15
3.8	364.41	0.18	446	1.1	0.22	510	B				C	C		90816	16
3.3	425.43	0.18	521	1.0	0.19	510	B				C	C		90814	17
2.9	481.19	0.18	589	0.9	0.17	510	B				C	C		70816	18
2.5	561.76	0.12	444	1.1	0.14	510	B				C	C		70814	19

The dynamic efficiency is **0.94** for all ratios

- Motor Flanges Available** Flange Motore Disponibili
- B) Supplied with Reduction Bushing** Fornito con Bussola di Riduzione
- B) Available on Request without reduction bushing** Disponibile a Richiesta senza Bussola di Riduzione
- C) Motor Flange Holes Position** Posizione Fori Flangia Motore

EN Unit **FA53** is supplied with synthetic oil for lifetime lubrication, no maintenance is necessary. See table 1 for lubrication and recommended quantity. In table 2 please see possible radial loads and axial loads on the gearbox.

I Il riduttore **FA53** viene fornito completo di olio sintetico per la lubrificazione permanente e non necessita di alcuna manutenzione. Vedi tab.1 per oli e quantità consigliati. In tab.2 sono presenti i carichi radiali e assiali applicabili al riduttore.

D Das Getriebe **FA53** ist mit synthetischem Öl gefüllt und ist lebensdauergeschmiert. In Tabelle 1 ist die Schmiermenge und das empfohlene Schmiermittel angegeben. In Tabelle 2 sind die zulässigen Radial- und Axialbelastungen des Getriebes aufgeführt.

F Le réducteur **FA53** est fourni complet avec de l'huile synthétique pour la lubrification permanente et ne nécessite aucun entretien. Voir tableau 1 concernant les huiles et les quantités conseillées. Les charges radiales et axiales applicables au réducteur sont précisées dans le tableau 2.

E El reductor tamaño **FA53** se suministra, lubricado de por vida con aceite sintético y no requieren mantenimiento alguna. Ver tabla 1, para cantidades y aceites recomendados. En la tabla 2, se encuentran las cargas radiales y axiales admitidas por el reductor.

Standard supplied	For these mounting position specify in the order or add oil Per queste posizioni specificare in fase d'ordine o aggiungere olio				
2.15 LT	1.25 LT	1.25 LT	1.45 LT	2.35 LT	1.45 LT
AGIP Telium VSF 320			SHELL Omala S4 WE 320		

For all details on lubrication and plugs check our website **tab. 1**
Per maggiori dettagli su lubrificazione e tappi olio vedi il nostro sito web

RADIAL AND AXIAL LOADS

Output shaft
Albero di uscita

$F_{eq} = FR \cdot \frac{149.5}{X+119.5}$

n_2	FA	FR	n_2	FA	FR	n_2	FA	FR
300	400	2000	140	460	2300	70	580	2900
250	420	2100	120	500	2500	40	780	3900
200	440	2200	85	550	2750	15	1140	5700

On request reinforced bearings to increase loads.
A richiesta cuscinetti rinforzati per aumentare i carichi.

Input shaft
Albero in entrata

n_1	FA	FR
1400	240	1200
900	280	1400
500	340	1700

tab. 2

PFA53C... Basic gearbox
Riduttore base

Gearbox weight
peso riduttore **15.5 kg**

M. flanges	Kit code	øF	A
63B5	K063.4.041	140	239
71B5	K063.4.042	160	237
80/90B5	K063.4.043	200	239
71B14	K063.4.047	105	237
80B14	K063.4.046	120	239
90B14	K063.4.041	140	239

● Available torque arms,
see our web site
Bracci di reazione disponibili,
consulta il nostro sito web

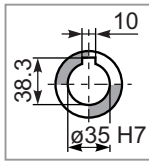

Standard
Hollow shaft

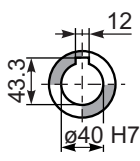

On request
A richiesta

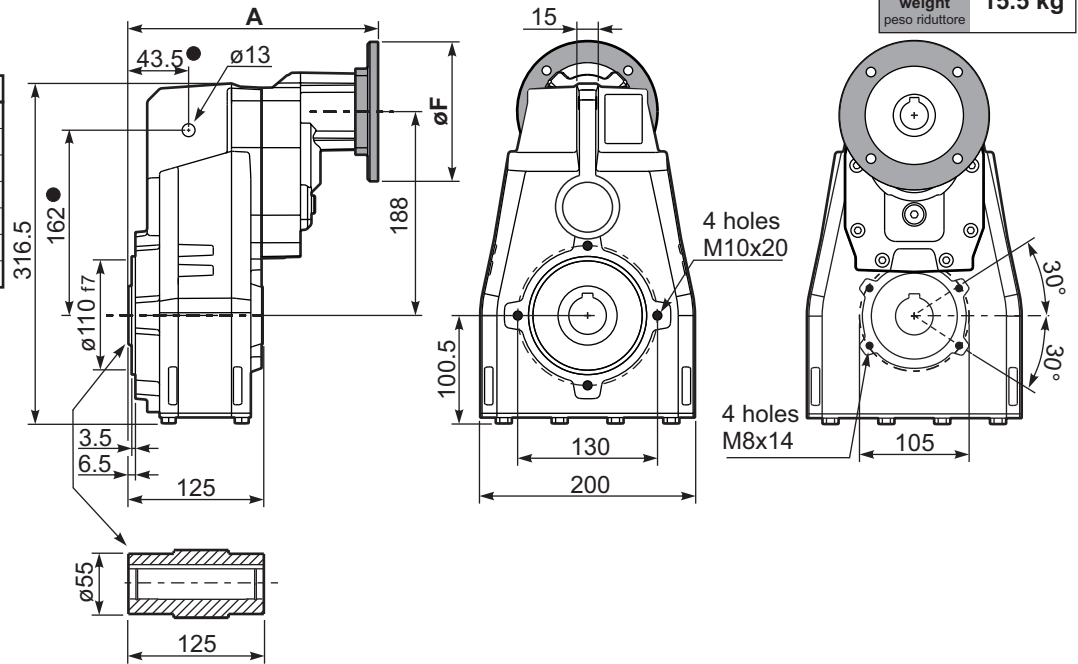

PFA53...-F... Output flange
Flangia uscita

Motor Flange	k1
63B5	272
71B5	270
80/90B5	272
71B14	270
80B14	271
90B14	272

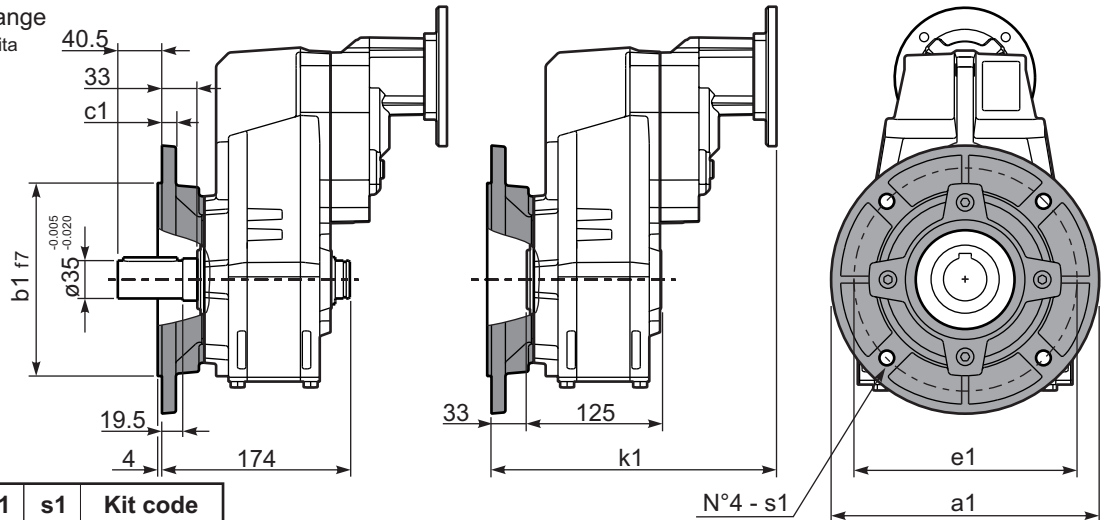

Available output flanges
Flange di uscita

a1 ø	b1	c1	e1	s1	Kit code
250	180	13	215	14	KF60.9.011
300	230	16	265	14	KF60.9.012

RFA53C... Input Shaft
Albero in entrata

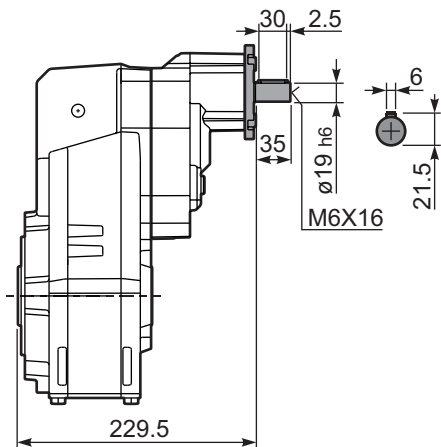

PFA53 A... Single output shaft
Albero uscita semplice

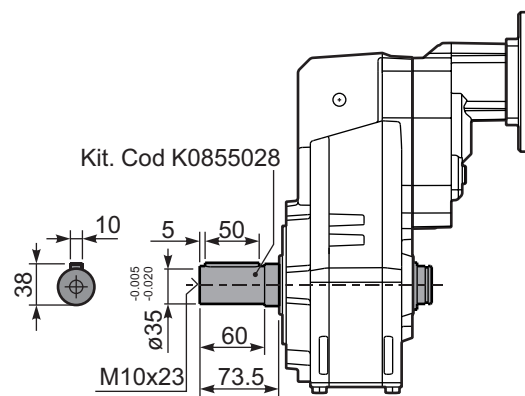

PFA53D... Shrink disk
Calettatore

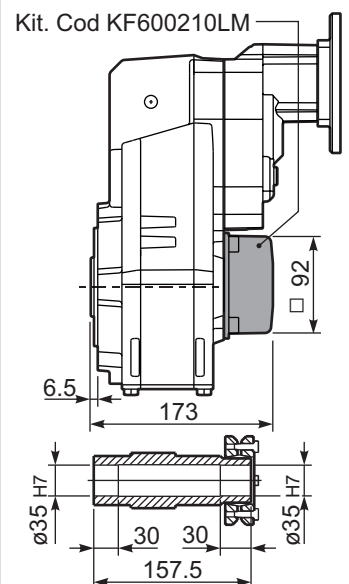



QUICK SELECTION / Selezione veloce input speed (n_1) = 1400 min⁻¹

Output Speed n_2 [min ⁻¹]	Ratio i	Motor power P_{1M} [kW]	Output torque M_{2M} [Nm]	Service factor f.s.	Nominal power P_{1R} [kW]	Nominal torque M_{2R} [Nm]	Available B5 motor flanges		B14 motor flanges				Output Shaft		
							G	132	-	-	-	-	-	-	Output Shaft
507	2.76	9	166	1.6	14.4	265			not available				2980	standard	01
395	3.54	9	213	1.3	11.6	275							2485	ø35	02
277	5.06	9	304	1.0	8.6	290							1891		03
241	5.81	7.5	281	1.2	8.5	330							1693	ø40	04
206	6.79	7.5	329	1.2	8.4	380							1495	On request	05

The dynamic efficiency is **0.98** for all ratios

Motor Flanges Available
Flange Motore Disponibili
B) Supplied with Reduction Bushing
Fornito con Bussola di Riduzione
B) Available on Request without reduction bushing
Disponibile a Richiesta senza Bussola di Riduzione
C) Motor Flange Holes Position
Posizione Fori Flangia Motore

EN Unit **FC61** is supplied with synthetic oil for lifetime lubrication, no maintenance is necessary. See table 1 for lubrication and recommended quantity. In table 2 please see possible radial loads and axial loads on the gearbox.

I Il riduttore **FC61** viene fornito completo di olio sintetico per la lubrificazione permanente e non necessita di alcuna manutenzione. Vedi tab.1 per oli e quantità consigliati. In tab.2 sono presenti i carichi radiali e assiali applicabili al riduttore.

D Das Getriebe **FC61** ist mit synthetischem Öl gefüllt und ist lebensdauergeschmiert. In Tabelle 1 ist die Schmiermenge und das empfohlene Schmiermittel angegeben. In Tabelle 2 sind die zulässigen Radial - und Axialbelastungen des Getriebes aufgeführt.

F Le réducteur **FC61** est fourni complet avec de l'huile synthétique pour la lubrification permanente et ne nécessite aucun entretien. Voir tableau 1 concernant les huiles et les quantités conseillées. Les charges radiales et axiales applicables au réducteur sont précisées dans le tableau 2.

E El reductor tamaño **FC61** se suministra, lubricado de por vida con aceite sintético y no requieren mantenimiento alguna. Ver tabla 1, para cantidades y aceites recomendados. En la tabla 2, se encuentran las cargas radiales y axiales admitidas por el reductor.

Standard supplied	For these mounting position specify in the order or add oil Per queste posizioni specificare in fase d'ordine o aggiungere olio				
1.85 LT	1.15 LT	1.15 LT	1.30 LT	1.95 LT	1.30 LT
AGIP Telium VSF 320			SHELL Omala S4 WE 320		

For all details on lubrication and plugs check our website tab. 1
Per maggiori dettagli su lubrificazione e tappi olio vedi il nostro sito web

RADIAL AND AXIAL LOADS								
Output shaft Albero di uscita			$F_{eq} = F_R \cdot \frac{149.5}{X+119.5}$					
n_2	FA	FR	n_2	FA	FR	n_2	FA	FR
300	600	3000	140	720	3600	70	940	4700
250	640	3200	120	740	3700	40	1220	6100
200	690	3460	85	860	4300	15	1300	6500

On request reinforced bearings to increase loads.
A richiesta cuscinetti rinforzati per aumentare i carichi.

tab. 2

PFC61C... Basic gearbox
Riduttore base

Gearbox weight
peso riduttore **31.0 kg**

- Available torque arms, see our web site
Bracci di reazione disponibili, consulta il nostro sito web

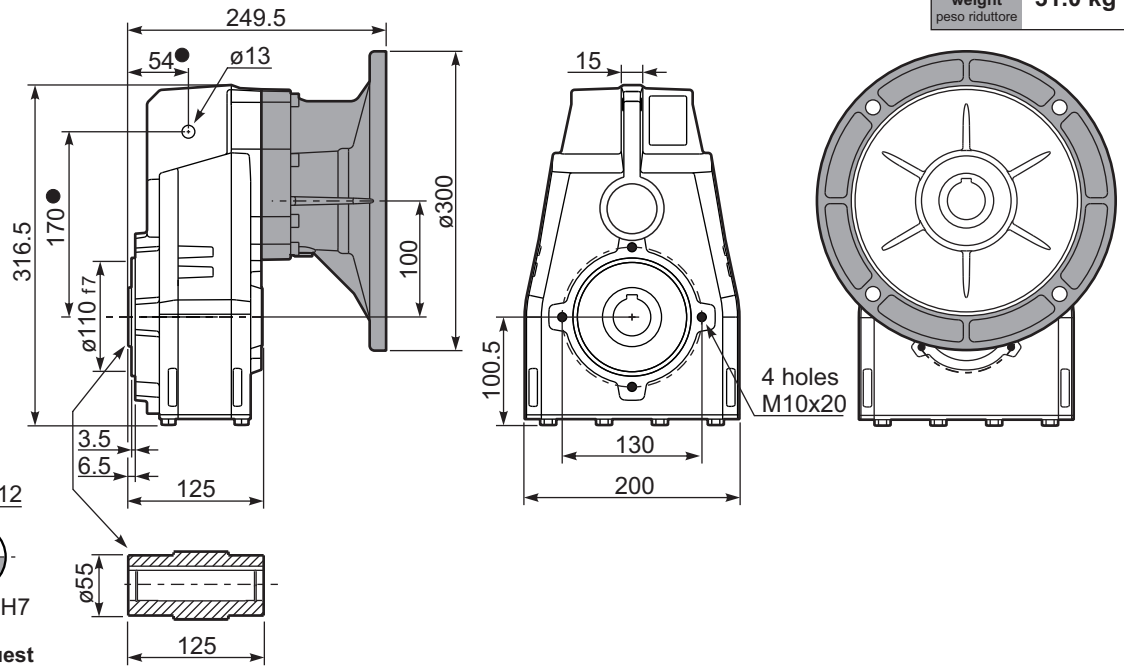

Standard
Hollow shaft

On request
A richiesta

PFC61...-F... Output flange
Flangia uscita

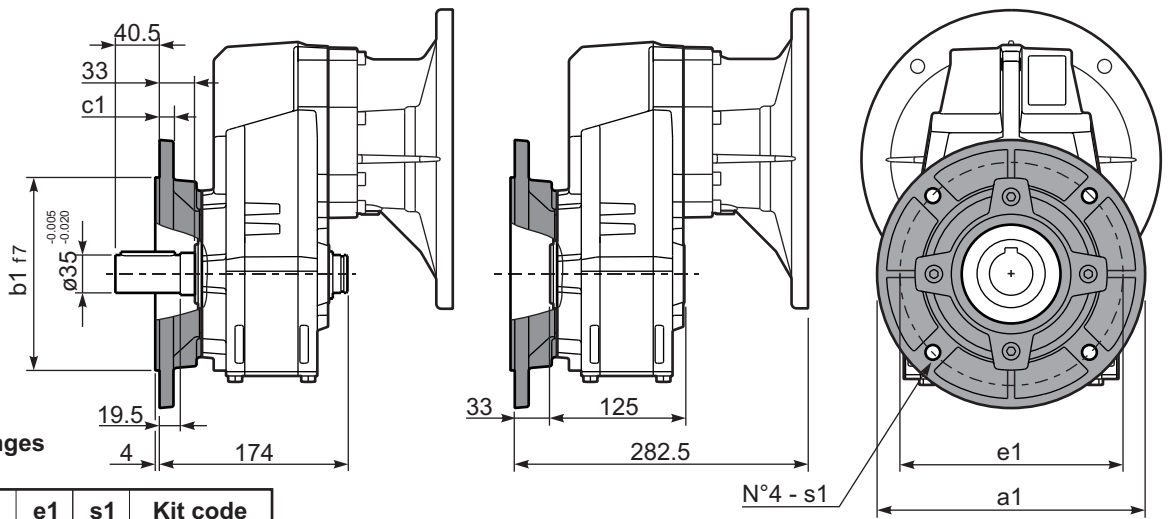

Available output flanges
Flange di uscita

a1 ϕ	b1	c1	e1	s1	Kit code
250	180	13	215	14	KF60.9.011
300	230	16	265	14	KF60.9.012

PFC61 A... Single output shaft
Albero uscita semplice

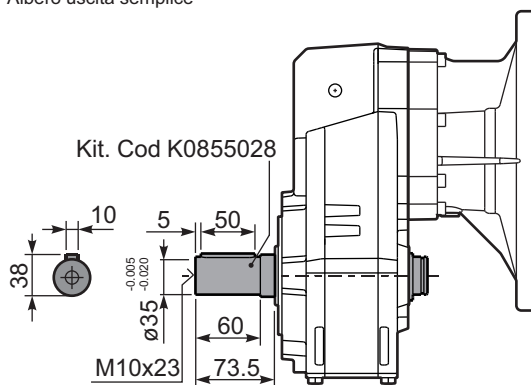



QUICK SELECTION / Selezione veloce

input speed (n_1) = 1400 min⁻¹

Output Speed n_2 [min ⁻¹]	Ratio i	Motor power P_{1M} [kW]	Output torque M_{2M} [Nm]	Service factor $f.s.$	Nominal power P_{1R} [kW]	Nominal torque M_{2R} [Nm]	Available B5 motor flanges					Available B14 motor flanges				Output Shaft 	Ratios code 	
							C	D	E	F	G	R	T	U	V			
							71	80	90	100 112	132	80	90	100 112	132			
213	6.57	7.5	312	1.2	8.8	380	B										3018	01
185	7.56	7.5	358	1.1	7.9	390	B										3016	02
159	8.82	7.5	419	1.0	7.1	410	B										3014	03
113	12.39	7.5	588	1.0	7.2	580	B										2018	04
98	14.24	5.5	499	1.2	6.4	600	B										2016	05
84	16.75	5.5	587	1.1	6.1	665	B										1618	06
73	19.25	5.5	675	1.0	5.4	675	B										1616	07
64	21.78	4	558	1.2	4.7	675	B										1318	08
56	25.04	4	642	1.1	4.1	675	B										1316	09
47.9	29.23	4	750	0.9	3.5	675	B										1314	10
45.7	30.65	3	592	1.1	3.4	675	B										1116	11
39.1	35.78	3	691	1.0	2.9	675	B										1114	12
36.3	38.55	2.2	548	1.1	2.3	580	B										818	13
31.6	44.32	2.2	630	1.1	2.3	665	B										816	14
27.1	51.74	2.2	735	0.9	2.0	675	B										814	15
22.9	61.03	1.1	437	1.1	1.2	480	B										616	16
19.6	71.25	1.1	510	1.1	1.2	560	B										614	17

The dynamic efficiency is **0.96** for all ratios

- Motor Flanges Available Flange Motore Disponibili
- Supplied with Reduction Bushing Fornito con Bussola di Riduzione
- Available on Request without reduction bushing Disponibile a Richiesta senza Bussola di Riduzione
- Motor Flange Holes Position Posizione Fori Flangia Motore

EN Unit **FC62** is supplied with synthetic oil for lifetime lubrication, no maintenance is necessary. See table 1 for lubrication and recommended quantity. In table 2 please see possible radial loads and axial loads on the gearbox.

I Il riduttore **FC62** viene fornito completo di olio sintetico per la lubrificazione permanente e non necessita di alcuna manutenzione. Vedi tab.1 per oli e quantità consigliati. In tab.2 sono presenti i carichi radiali e assiali applicabili al riduttore.

D Das Getriebe **FC62** ist mit synthetischem Öl gefüllt und ist lebensdauergeschmiert. In Tabelle 1 ist die Schmiermenge und das empfohlene Schmiermittel angegeben. In Tabelle 2 sind die zulässigen Radial- und Axialbelastungen des Getriebes aufgeführt.

F Le réducteur **FC62** est fourni complet avec de l'huile synthétique pour la lubrification permanente et ne nécessite aucun entretien. Voir tableau 1 concernant les huiles et les quantités conseillées. Les charges radiales et axiales applicables au réducteur sont précisées dans le tableau 2.

E El reductor tamaño **FC62** se suministra, lubricado de por vida con aceite sintético y no requieren mantenimiento alguna. Ver tabla 1, para cantidades y aceites recomendados. En la tabla 2, se encuentran las cargas radiales y axiales admitidas por el reductor.

Standard supplied	For these mounting position specify in the order or add oil Per queste posizioni specificare in fase d'ordine o aggiungere olio				
1.85 LT	1.15 LT	1.15 LT	1.30 LT	2.10 LT	1.30 LT
AGIP Telium VSF 320			SHELL Omala S4 WE 320		

For all details on lubrication and plugs check our website **tab. 1**
Per maggiori dettagli su lubrificazione e tappi olio vedi il nostro sito web

RADIAL AND AXIAL LOADS

Output shaft
Albero di uscita

$F_{eq} = FR \cdot \frac{149.5}{X+119.5}$

n_2	FA	FR	n_2	FA	FR	n_2	FA	FR
300	600	3000	140	720	3600	70	940	4700
250	640	3200	120	740	3700	40	1220	6100
200	690	3460	85	860	4300	15	1300	6500

On request reinforced bearings to increase loads.
A richiesta cuscinetti rinforzati per aumentare i carichi.

Input shaft
Albero in entrata

n_1	FA	FR
1400	400	2000
900	440	2200
500	440	2200

tab. 2

PFC62C...

Basic gearbox
Riduttore base

Gearbox weight
peso riduttore **20.8 kg**

M. flanges	Kit code	øF	A
71B5	KC023.4.041	160	227
80/90B5	KC023.4.042	200	229
100/112B5	KC023.4.043	250	238
132B5	KC50.4.043	300	256
80B14	KC085.4.046	120	229
90B14	KC085.4.045	140	229
100/112B14	KC085.4.047	160	238
132B14	KC50.4.041	200	256

● Available torque arms,
see our web site
Bracci di reazione disponibili,
consulta il nostro sito web

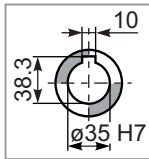

Standard
Hollow shaft

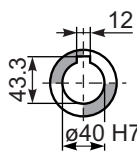

On request
A richiesta

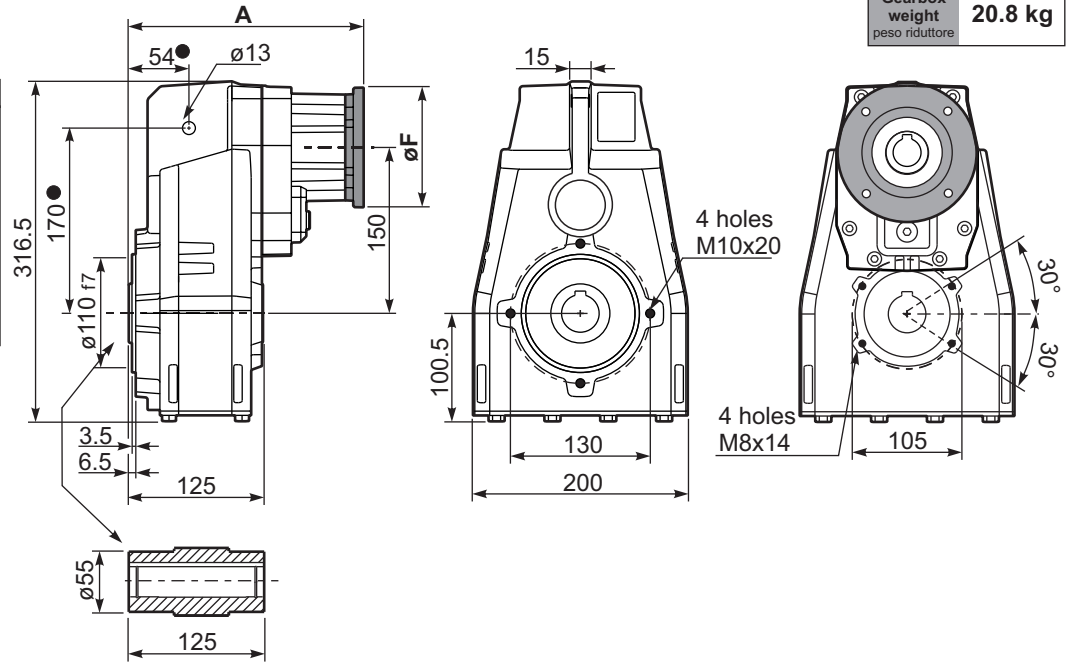

PFC62...-F...

Output flange
Flangia uscita

M. flanges	k1
71B5	260
80/90B5	262
100/112B5	268
132B5	289.5
80B14	260
90B14	260
100/112B14	271
132B14	289.5

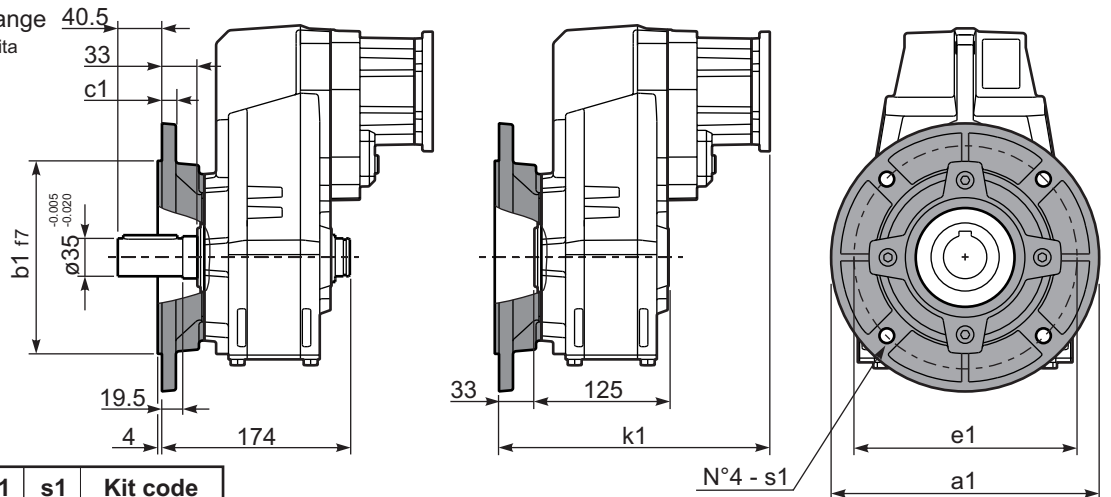

Available output flanges
Flange di uscita

a1 ø	b1	c1	e1	s1	Kit code
250	180	13	215	14	KF60.9.011
300	230	16	265	14	KF60.9.012

RFC62C...

Input Shaft
Albero in entrata

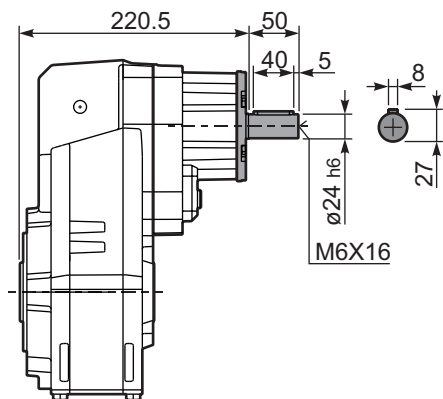

PFC62 A...

Single output shaft
Albero uscita semplice

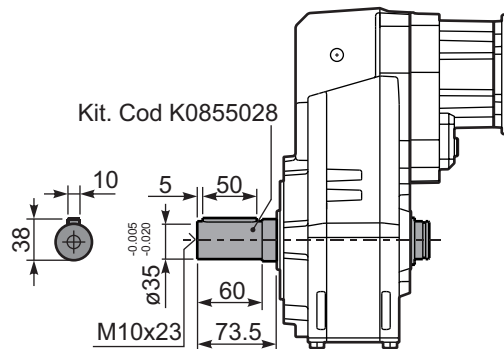

PFC62D...

Shrink disk
Calettatore

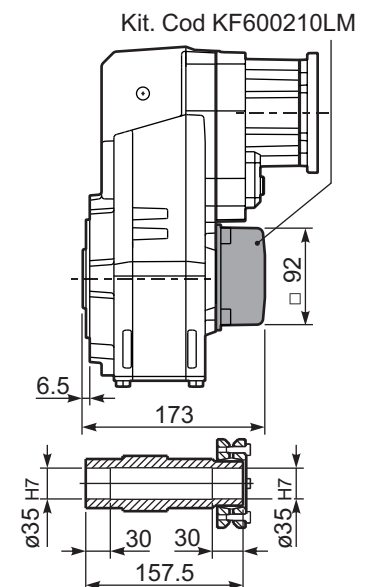



QUICK SELECTION / Selezione veloce

input speed (n_1) = 1400 min⁻¹

Output Speed n_2 [min ⁻¹]	Ratio i	Motor power P_{1M} [kW]	Output torque M_{2M} [Nm]	Service factor f.s.	Nominal power P_{1R} [kW]	Nominal torque M_{2R} [Nm]	Available B5 motor flanges				Available B14 motor flanges			Output Shaft 	Ratios code
							B	C	D	E	Q	R	T		
							63	71	80	90	71	80	90		
22.6	61.89	1.5	594	1.1	1.7	675	B				C	C		191318	01
19.7	71.16	1.5	683	1.0	1.5	675	B				C	C		191316	02
17.0	82.48	1.5	792	0.9	1.3	675	B				C	C		171316	03
14.5	96.29	1.1	675	1.0	1.1	675	B				C	C		171314	04
13.9	100.51	1.1	705	1.0	1.0	675	B				C	C		131318	05
12.1	115.56	0.75	556	1.2	0.91	675	B				C	C		131316	06
11.1	125.96	0.75	606	1.1	0.82	665	B				C	C		190816	07
10.4	134.91	0.75	649	1.0	0.78	675	B				C	C		131314	08
9.5	147.05	0.75	707	1.0	0.72	675	B				C	C		190814	09
8.2	170.44	0.55	605	1.1	0.62	675	B				C	C		170814	10
7.6	184.15	0.55	653	1.0	0.57	675	B				C	C		101314	11
6.8	205.87	0.55	730	0.9	0.51	675	B				C	C		91316	12
5.8	240.34	0.37	570	1.2	0.44	675	B				C	C		91314	13
5.0	279.22	0.37	662	1.0	0.37	665	B				C	C		100816	14
4.3	325.97	0.37	773	0.9	0.32	675	B				C	C		100814	15
3.8	364.41	0.25	583	1.1	0.28	665	B				C	C		90816	16
3.3	425.43	0.25	681	1.0	0.25	675	B				C	C		90814	17
2.9	481.19	0.18	589	1.1	0.22	665	B				C	C		70816	18
2.5	561.76	0.18	687	1.0	0.19	675	B				C	C		70814	19

The dynamic efficiency is 0.94 for all ratios

- Motor Flanges Available Flange Motore Disponibili
- Supplied with Reduction Bushing Fornito con Bussola di Riduzione
- Available on Request without reduction bushing Disponibile a Richiesta senza Bussola di Riduzione
- Motor Flange Holes Position Posizione Fori Flangia Motore

EN Unit FC63 is supplied with synthetic oil for lifetime lubrication, no maintenance is necessary. See table 1 for lubrication and recommended quantity. In table 2 please see possible radial loads and axial loads on the gearbox.

I Il riduttore FC63 viene fornito completo di olio sintetico per la lubrificazione permanente e non necessita di alcuna manutenzione. Vedi tab.1 per oli e quantità consigliati. In tab.2 sono presenti i carichi radiali e assiali applicabili al riduttore.

D Das Getriebe FC63 ist mit synthetischem Öl gefüllt und ist lebensdauergeschmiert. In Tabelle 1 ist die Schmiermenge und das empfohlene Schmiermittel angegeben. In Tabelle 2 sind die zulässigen Radial - und Axialbelastungen des Getriebes aufgeführt.

F Le réducteur FC63 est fourni complet avec de l'huile synthétique pour la lubrification permanente et ne nécessite aucun entretien. Voir tableau 1 concernant les huiles et les quantités conseillées. Les charges radiales et axiales applicables au réducteur sont précisées dans le tableau 2.

E El reductor tamaño FC63 se suministra, lubricado de por vida con aceite sintético y no requieren mantenimiento alguna. Ver tabla 1, para cantidades y aceites recomendados. En la tabla 2, se encuentran las cargas radiales y axiales admitidas por el reductor.

Standard supplied	For these mounting position specify in the order or add oil Per queste posizioni specificare in fase d'ordine o aggiungere olio				
2.15 LT	1.25 LT	1.25 LT	1.45 LT	2.35 LT	1.45 LT
AGIP Telium VSF 320			SHELL Omala S4 WE 320		

For all details on lubrication and plugs check our website **tab. 1**
Per maggiori dettagli su lubrificazione e tappi olio vedi il nostro sito web

RADIAL AND AXIAL LOADS

Output shaft
Albero di uscita

$F_{eq} = FR \cdot \frac{149.5}{X+119.5}$

n_2	FA	FR	n_2	FA	FR	n_2	FA	FR
300	600	3000	140	720	3600	70	940	4700
250	640	3200	120	740	3700	40	1220	6100
200	690	3460	85	860	4300	15	1300	6500

On request reinforced bearings to increase loads.
A richiesta cuscinetti rinforzati per aumentare i carichi.

Input shaft
Albero in entrata

n_1	FA	FR
1400	240	1200
900	280	1400
500	340	1700

tab. 2



QUICK SELECTION / Selezione veloce

input speed (n_1) = 1400 min⁻¹

Output Speed n_2 [min ⁻¹]	Ratio i	Motor power P_{1M} [kW]	Output torque M_{2M} [Nm]	Service factor f.s.	Nominal power P_{1R} [kW]	Nominal torque M_{2R} [Nm]	Available B5 motor flanges					Available B14 motor flanges				Output Shaft 	Ratios code 	
							C	D	E	F	G	R	T	U	V			
							71	80	90	100 112	132	80	90	100 112	132			
175	8.02	9	473	1.1	9.9	520	B										3018	01
152	9.18	9	541	1.1	9.8	590	B										3016	02
131	10.68	9	630	1.1	9.7	680	B										3014	03
93	15.11	7.5	717	1.1	7.8	775	B										2018	04
81	17.30	7.5	821	1.1	7.8	885	B										2016	05
70	20.13	7.5	955	0.9	6.8	900	B										2014	06
60	23.39	5.5	820	1.1	5.9	900	B										1616	07
51	27.21	5.5	954	0.9	5.1	900	B										1614	08
46.0	30.42	4	780	1.2	4.5	900	B										1316	09
39.6	35.38	4	907	1.0	3.9	900	B										1314	10
37.6	37.24	3	719	1.2	3.7	895	B										1116	11
32.3	43.31	3	836	1.1	3.2	900	B										1114	12
29.8	47.02	2.2	668	1.1	2.3	705	B										818	13
26.0	53.85	2.2	765	1.1	2.3	810	B										816	14
22.4	62.63	2.2	890	1.0	2.2	900	B										814	15
18.9	74.16	1.1	531	1.1	1.2	585	B										616	16
16.2	86.25	1.1	617	1.1	1.2	680	B										614	17

The dynamic efficiency is **0.96** for all ratios

- Motor Flanges Available** Flange Motore Disponibili
- B) Supplied with Reduction Bushing** Fornito con Bussola di Riduzione
- B) Available on Request without reduction bushing** Disponibile a Richiesta senza Bussola di Riduzione
- C) Motor Flange Holes Position** Posizione Fori Flangia Motore

EN Unit **FC72** is supplied without lubricant and equipped with a breather, level and drain plugs. User can add mineral oil keeping existing plugs. Should the user wish to fill it with synthetic oil, it is recommended to replace the existing plugs with a closed plug. See table 1 for lubrication and recommended quantity. In table 2 please see possible radial loads and axial loads on the gearbox.

H1	H4	H3	H2	H5	H6
3.50 LT	1.90 LT	1.90 LT	1.80 LT	3.60 LT	1.90 LT
AGIP Blasias 460					

For all details on lubrication and plugs check our website **tab. 1**
Per maggiori dettagli su lubrificazione e tappi olio vedi il nostro sito web

I Il riduttore tipo **FC72** è fornito privo di lubrificazione con tappi di sfiato, livello e scarico olio. L'utente può immettere olio minerale mantenendo i tappi esistenti. Se immetterà olio sintetico, dovrà sostituire i tappi esistenti con altri tipo chiuso. Tab.1 per oli e quantità consigliati. Tab.2 carichi radiali e assiali applicabili al riduttore.

D Das Getriebe der Baugröße **FC72** wird ohne Schmiermittel geliefert. Es ist jedoch mit Einfüllschraube, Überdruckventil und Ablassschraube ausgerüstet. Das benötigte mineralische Öl kann über die Einfüllschraube eingefüllt werden. Sollte synthetisches Öl bevorzugt werden, so ist sind das eingebaute Überdruckventil durch eine geschlossenen Schraube zu ersetzen. In Tabelle 1 ist die Schmiermenge und das empfohlene Schmiermittel angegeben. In Tabelle 2 sind die zulässigen Radial - und Axialbelastungen des Getriebes aufgeführt.

F Le réducteur de type **FC72** est fourni sans lubrification et avec un bouchon de remplissage, de niveau et d'évacuation de l'huile. L'utilisateur peut y verser de l'huile minérale en conservant les bouchons existants. S'il y versera de l'huile synthétique, il devra substituer les bouchons existants avec d'autres bouchons de type fermé. Voir tableau 1 concernant les huiles et les quantités conseillées. Voir tableau 2 concernant les charges radiales et axiales applicables au réducteur.

E El reductor tamaño **FC72** se suministra sin lubricante, provisto de tapones de respiración, nivel y descarga de aceite. El usuario puede utilizar aceite mineral, manteniendo los tapones existentes. Si prefiere utilizar aceite sintético deberá sustituir los tapones existentes por tapones ciegos. La prerreducción se suministra con tapones ciegos, lubricado de por vida con aceite sintético. Ver tabla 1, para cantidades y aceites recomendados. En la tabla 2, se encuentran las cargas radiales y axiales admitidas por el reductor.

RADIAL AND AXIAL LOADS

Output shaft
Albero di uscita

$F_{eq} = F_R \cdot \frac{174.5}{X+134.5}$

n_2	FA	FR	n_2	FA	FR	n_2	FA	FR
300	740	3700	140	860	4300	70	1020	5100
250	800	4000	120	900	4500	40	1300	6500
200	830	4150	85	970	4850	15	1700	8500

On request reinforced bearings to increase loads.
A richiesta cuscinetti rinforzati per aumentare i carichi.

Input shaft
Albero in entrata

n_1	FA	FR
1400	450	2250
900	500	2500
500	600	3000

tab. 2

PFC72C...

Basic gearbox
Riduttore base

M. flanges	Kit code	øF	A
71B5	KC023.4.041	160	238.5
80/90B5	KC023.4.042	200	240.5
100/112B5	KC023.4.043	250	249.5
132B5	KC50.4.043	300	267.5
80B14	KC085.4.046	120	240.5
90B14	KC085.4.045	140	240.5
100/112B14	KC085.4.047	160	249.5
132B14	KC50.4.041	200	267.5

● Available torque arms,
see our web site
Bracci di reazione disponibili,
consulta il nostro sito web

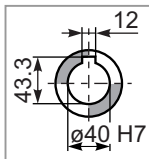

Standard
Hollow shaft

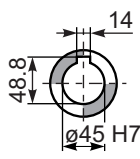

On request
A richiesta

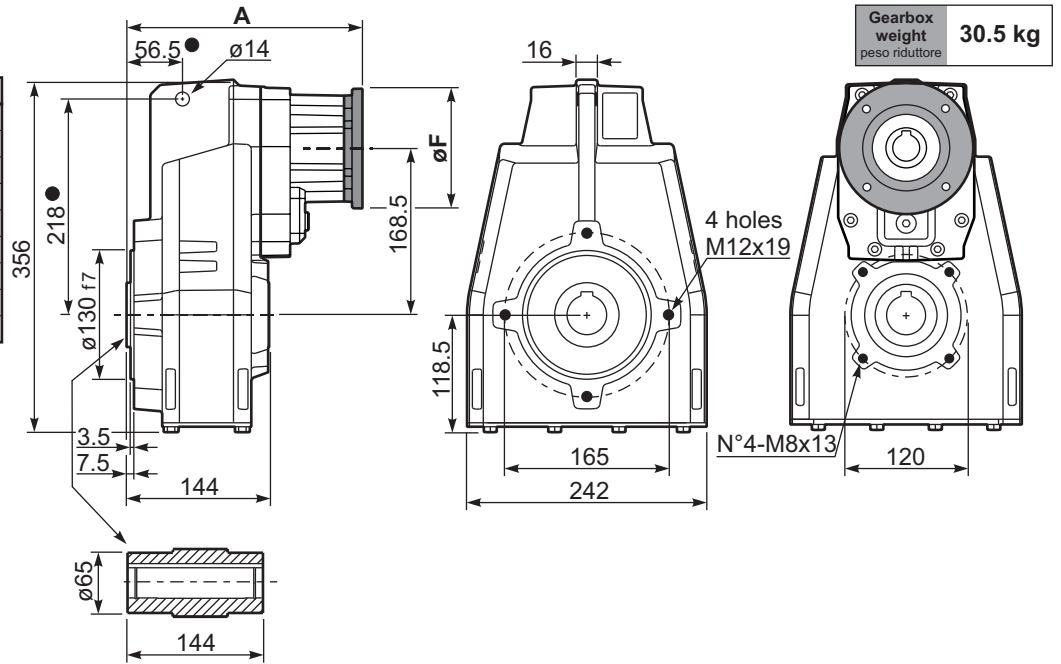

Gearbox weight
peso riduttore **30.5 kg**

PFC72...-F...

Output flange
Flangia uscita

M. flanges	k1
71B5	271
80/90B5	273
100/112B5	279
132B5	300.5
80B14	271
90B14	271
100/112B14	282
132B14	300.5

Available output flanges
Flange di uscita

a1 ø	b1	c1	e1	f1	s1	Kit code
250	180	13	215	3	14	KF70.9.011
300	230	16	265	4	14	KF70.9.012
350	250	18	300	4	18	KF70.9.013

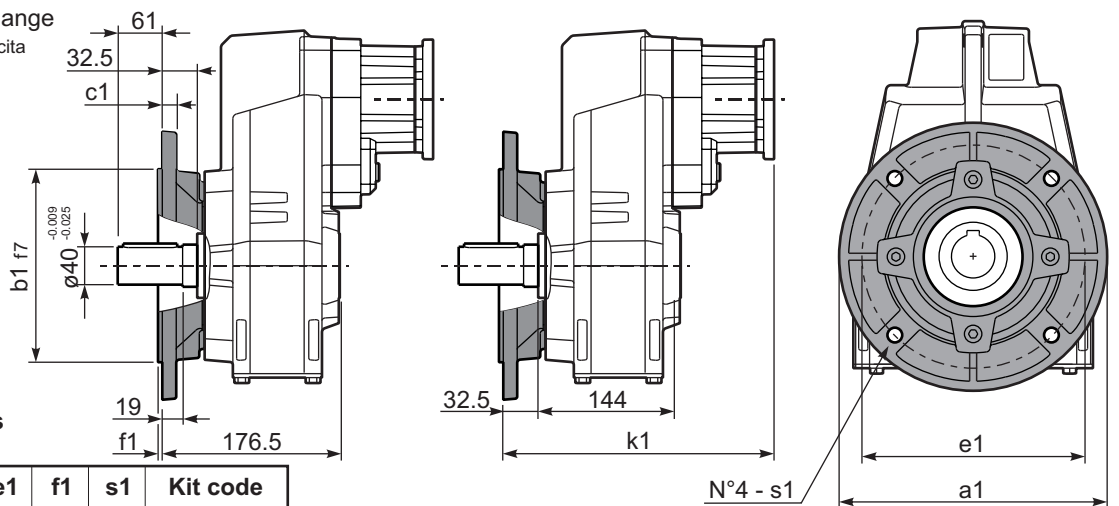

RFC72C...

Input Shaft
Albero in entrata

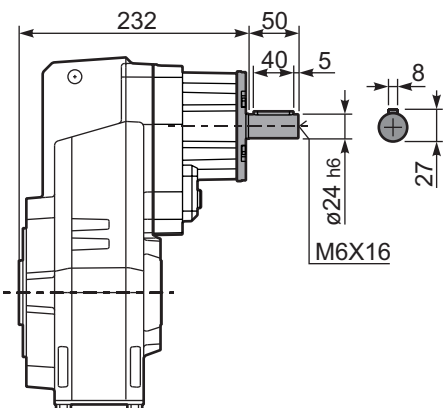

PFC72 A...

Single output shaft
Albero uscita semplice

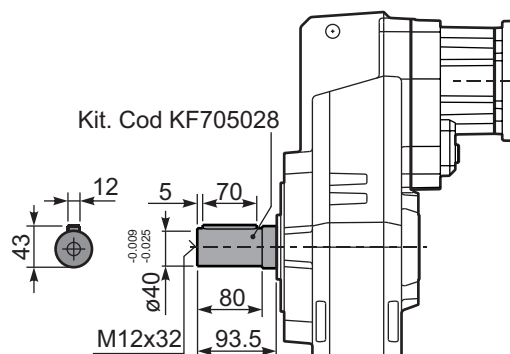

PFC72D...

Shrink disk
Calettatore

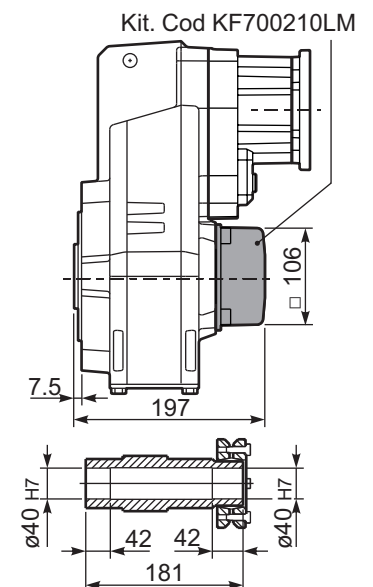



QUICK SELECTION / Selezione veloce

input speed (n_1) = 1400 min⁻¹

Output Speed n_2 [min ⁻¹]	Ratio i	Motor power P_{1M} [kW]	Output torque M_{2M} [Nm]	Service factor f.s.	Nominal power P_{1R} [kW]	Nominal torque M_{2R} [Nm]	Available B5 motor flanges				Available B14 motor flanges			Output Shaft 	Ratios code
							B	C	D	E	Q	R	T		
							63	71	80	90	71	80	90		
18.5	75.50	1.5	725	1.1	1.7	825	B				C	C		191318	01
16.2	86.47	1.5	830	1.1	1.6	900	B				C	C		191316	02
14.0	100.22	1.5	962	0.9	1.4	900	B				C	C		171316	03
12.0	116.56	1.1	817	1.1	1.2	900	B				C	C		171314	04
10.2	136.82	1.1	959	0.9	1.0	900	B				C	C		151314	05
9.1	153.05	0.75	736	1.1	0.83	810	B				C	C		190816	06
8.6	163.31	0.75	785	1.1	0.86	900	B				C	C		131314	07
7.9	178.01	0.75	856	1.1	0.79	900	B				C	C		190814	08
7.3	191.67	0.75	922	1.0	0.73	900	B				C	C		101316	09
6.8	206.32	0.75	992	0.9	0.68	900	B				C	C		170814	10
6.3	222.92	0.55	791	1.1	0.63	900	B				C	C		101314	11
5.8	242.18	0.55	859	1.0	0.58	900	B				C	C		150814	12
5.6	250.15	0.55	888	1.0	0.56	900	B				C	C		91316	13
4.8	289.08	0.55	1026	0.9	0.49	900	B				C	C		130814	14
4.2	330.31	0.37	783	1.1	0.42	890	B				C	C		71316	15
3.5	394.59	0.37	936	1.0	0.36	900	B				C	C		100814	16
2.7	514.99	0.25	824	1.1	0.27	900	B				C	C		90814	17
2.1	680.03	0.18	832	1.1	0.21	900	B				C	C		70814	18

The dynamic efficiency is **0.94** for all ratios

Motor Flanges Available
Flange Motore Disponibili

B) Supplied with Reduction Bushing
Fornito con Bussola di Riduzione

B) Available on Request without reduction bushing
Disponibile a Richiesta senza Bussola di Riduzione

C) Motor Flange Holes Position
Posizione Fori Flangia Motore

EN Unit FC73 is supplied without lubricant and equipped with a breather, level and drain plugs. User can add mineral oil keeping existing plugs. Should the user wish to fill it with synthetic oil, it is recommended to replace the existing plugs with a closed plug. See table 1 for lubrication and recommended quantity. In table 2 please see possible radial loads and axial loads on the gearbox.

I Il riduttore tipo FC73 è fornito privo di lubrificazione con tappi di sfiato, livello e scarico olio. L'utente può immettere olio minerale mantenendo i tappi esistenti. Se immetterà olio sintetico, dovrà sostituire i tappi esistenti con altri tipo chiuso. Tab.1 per oli e quantità consigliati. Tab.2 carichi radiali e assiali applicabili al riduttore.

D Das Getriebe der Baugröße FC73 wird ohne Schmiermittel geliefert. Es ist jedoch mit Einfüllschraube, Überdruckventil und Ablaßschraube ausgerüstet. Das benötigte mineralische Öl kann über die Einfüllschraube eingefüllt werden. Sollte synthetisches Öl bevorzugt werden, so ist sind das eingebaute Überdruckventil durch eine geschlossenen Schraube zu ersetzen. In Tabelle 1 ist die Schmiermenge und das empfohlene Schmiermittel angegeben. In Tabelle 2 sind die zulässigen Radial - und Axialbelastungen des Getriebes aufgeführt.

F Le réducteur de type FC73 est fourni sans lubrification et avec un bouchon de remplissage, de niveau et d'évacuation de l'huile. L'utilisateur peut y verser de l'huile minérale en conservant les bouchons existants. S'il y versera de l'huile synthétique, il devra substituer les bouchons existants avec d'autres bouchons de type fermé. Voir tableau 1 concernant les huiles et les quantités conseillées. Voir tableau 2 concernant les charges radiales et axiales applicables au réducteur

E El reductor tamaño FC73 se suministra sin lubricante, provisto de tapones de respiración, nivel y descarga de aceite. El usuario puede utilizar aceite mineral, manteniendo los tapones existentes. Si prefiere utilizar aceite sintético deberá sustituir los tapones existentes por tapones ciegos. La prerreducción se suministra con tapones ciegos, lubricado de por vida con aceite sintético. Ver tabla 1, para cantidades y aceites recomendados. En la tabla 2, se encuentran las cargas radiales y axiales admitidas por el reductor.

H1	H4	H3	H2	H5	H6
3.55 LT	1.95 LT	1.95 LT	1.95 LT	3.75 LT	2.00 LT

AGIP Blasias 460

For all details on lubrication and plugs check our website **tab. 1**
Per maggiori dettagli su lubrificazione e tappi olio vedi il nostro sito web

RADIAL AND AXIAL LOADS

Output shaft
Albero di uscita

$F_{eq} = F_R \cdot 174.5 \cdot X + 134.5$

n_2	FA	FR	n_2	FA	FR	n_2	FA	FR
300	740	3700	140	860	4300	70	1020	5100
250	800	4000	120	900	4500	40	1300	6500
200	830	4150	85	970	4850	15	1700	8500

On request reinforced bearings to increase loads.
A richiesta cuscinetti rinforzati per aumentare i carichi.

Input shaft
Albero in entrata

n_1	FA	FR
1400	400	2000
900	440	2200
500	440	2200

tab. 2

PFC73C... Basic gearbox
Riduttore base

Gearbox weight
peso riduttore **30.5 kg**

M. flanges	Kit code	øF	A
63B5	K063.4.041	140	250.5
71B5	K063.4.042	160	248.5
80/90B5	K063.4.043	200	250.5
71B14	K063.4.047	105	248.5
80B14	K063.4.046	120	250.5
90B14	K063.4.041	140	250.5

● Available torque arms,
see our web site
Bracci di reazione disponibili,
consulta il nostro sito web

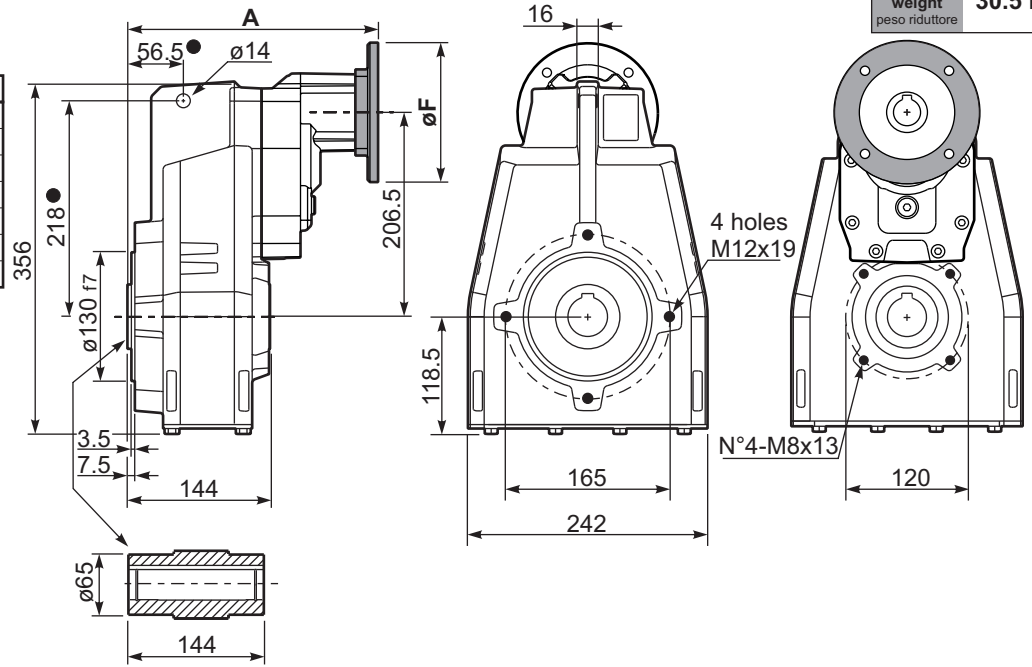
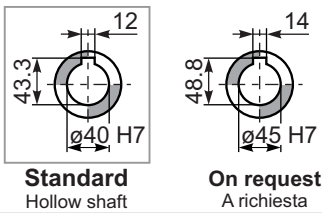

PFC73...-F... Output flange
Flangia uscita

M. flanges	k1
63B5	283
71B5	281
80/90B5	283
71B14	281
80B14	282
90B14	283

Available output flanges
Flange di uscita

a1 ø	b1	c1	e1	f1	s1	Kit code
250	180	13	215	3	14	KF70.9.011
300	230	16	265	4	14	KF70.9.012
350	250	18	300	4	18	KF70.9.013

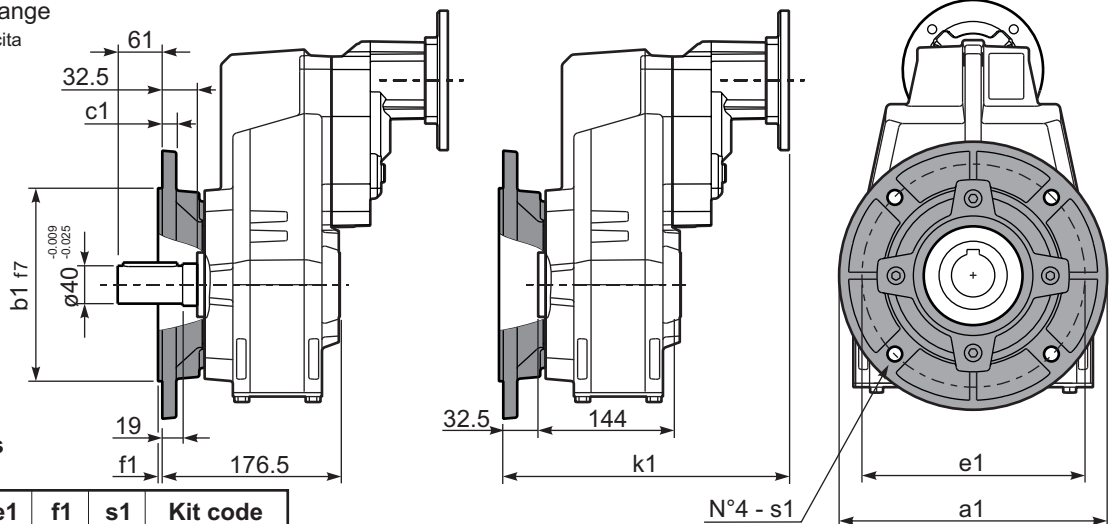

RFC73C... Input Shaft
Albero in entrata

PFC73 A... Single output shaft
Albero uscita semplice

PFC73D... Shrink disk
Calettatore

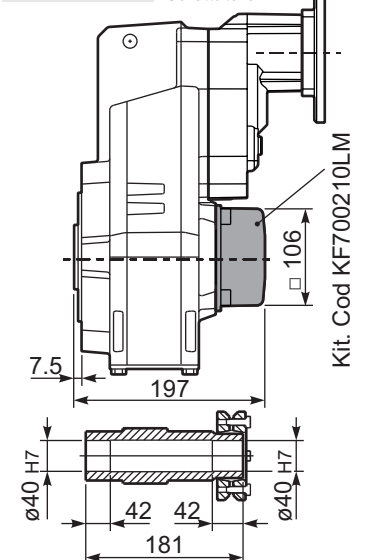
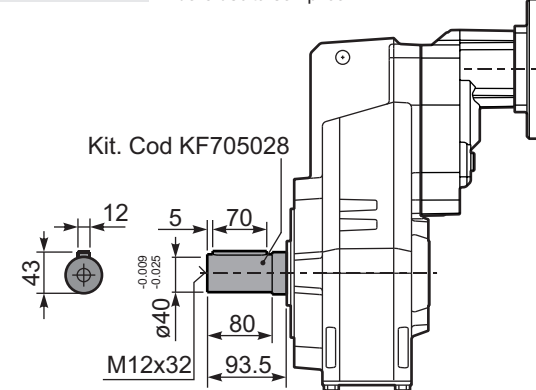
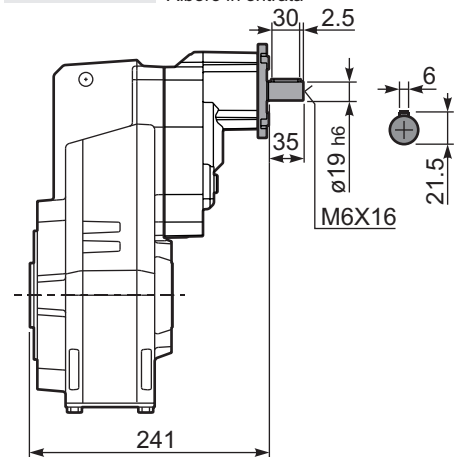



QUICK SELECTION / Selezione veloce

input speed (n_1) = 1400 min⁻¹

Output Speed n_2 [min ⁻¹]	Ratio i	Motor power P_{1M} [kW]	Output torque M_{2M} [Nm]	Service factor f.s.	Nominal power P_{1R} [kW]	Nominal torque M_{2R} [Nm]	Available B5 motor flanges		B14 motor flanges				Output Shaft 	Ratios code	
							H	I	-	-	-	-			
							160	180	-	-	-	-			
528	2.65	22	374	1.7	36.7	650			not available				2361	standard	01
409	3.42	22	483	1.6	32.8	750							1965	ø50	02
304	4.60	22	649	1.5	30.9	950							1569		03
256	5.46	22	771	1.3	27.4	1000							1371	ø55	04
211	6.64	22	937	1.3	26.5	1175							1173	On request	05

The dynamic efficiency is **0.98** for all ratios

Motor Flanges Available
Flange Motore Disponibili

B) Supplied with Reduction Bushing
Fornito con Bussola di Riduzione

B) Available on Request without reduction bushing
Disponibile a Richiesta senza Bussola di Riduzione

C) Motor Flange Holes Position
Posizione Fori Flangia Motore

EN Unit **FC81** is supplied without lubricant and equipped with a breather, level and drain plugs. User can add mineral oil keeping existing plugs. Should the user wish to fill it with synthetic oil, it is recommended to replace the existing plugs with a closed plug. See table 1 for lubrication and recommended quantity. In table 2 please see possible radial loads and axial loads on the gearbox.

I Il riduttore tipo **FC81** è fornito privo di lubrificazione con tappi di sfiato, livello e scarico olio. L'utente può immettere olio minerale mantenendo i tappi esistenti. Se immetterà olio sintetico, dovrà sostituire i tappi esistenti con altri tipo chiuso. Tab.1 per oli e quantità consigliati. Tab.2 carichi radiali e assiali applicabili al riduttore.

D Das Getriebe der Baugröße **FC81** wird ohne Schmiermittel geliefert. Es ist jedoch mit Einfüllschraube, Überdruckventil und Ablassschraube ausgerüstet. Das benötigte mineralische Öl kann über die Einfüllschraube eingefüllt werden. Sollte synthetisches Öl bevorzugt werden, so ist sind das eingebaute Überdruckventil durch eine geschlossenen Schraube zu ersetzen. In Tabelle 1 ist die Schmiermenge und das empfohlene Schmiermittel angegeben. In Tabelle 2 sind die zulässigen Radial - und Axialbelastungen des Getriebes aufgeführt.

F Le réducteur de type **FC81** est fourni sans lubrification et avec un bouchon de remplissage, de niveau et d'évacuation de l'huile. L'utilisateur peut y verser de l'huile minérale en conservant les bouchons existants. S'il y versera de l'huile synthétique, il devra substituer les bouchons existants avec d'autres bouchons de type fermé. Voir tableau 1 concernant les huiles et les quantités conseillées. Voir tableau 2 concernant les charges radiales et axiales applicables au réducteur

E El reductor tamaño **FC81** se suministra sin lubricante, provisto de tapones de respiración, nivel y descarga de aceite. El usuario puede utilizar aceite mineral, manteniendo los tapones existentes. Si prefiere utilizar aceite sintético deberá sustituir los tapones existentes por tapones ciegos. La prerreducción se suministra con tapones ciegos, lubricado de por vida con aceite sintético. Ver tabla 1, para cantidades y aceites recomendados. En la tabla 2, se encuentran las cargas radiales y axiales admitidas por el reductor.

H1	H4	H3	H2	H5	H6
5.50 LT	3.50 LT	3.50 LT	3.50 LT	6.20 LT	4.40 LT
AGIP Blasias 460					

For all details on lubrication and plugs check our website **tab. 1**
Per maggiori dettagli su lubrificazione e tappi olio vedi il nostro sito web

RADIAL AND AXIAL LOADS

Output shaft
Albero di uscita

$F_{eq} = F_R \cdot \frac{227.5}{X+177.5}$

n_2	FA	FR	n_2	FA	FR	n_2	FA	FR
300	920	4600	140	1120	5600	70	1400	7000
250	1000	5000	120	1140	5700	40	1800	9000
200	1060	5300	85	1300	6500	15	2400	12000

On request reinforced bearings to increase loads.
A richiesta cuscinetti rinforzati per aumentare i carichi.

tab. 2

PFC81C...

Basic gearbox
Riduttore base

Gearbox weight
peso riduttore **78.0 kg**

- Available torque arms, see our web site
Bracci di reazione disponibili, consulta il nostro sito web

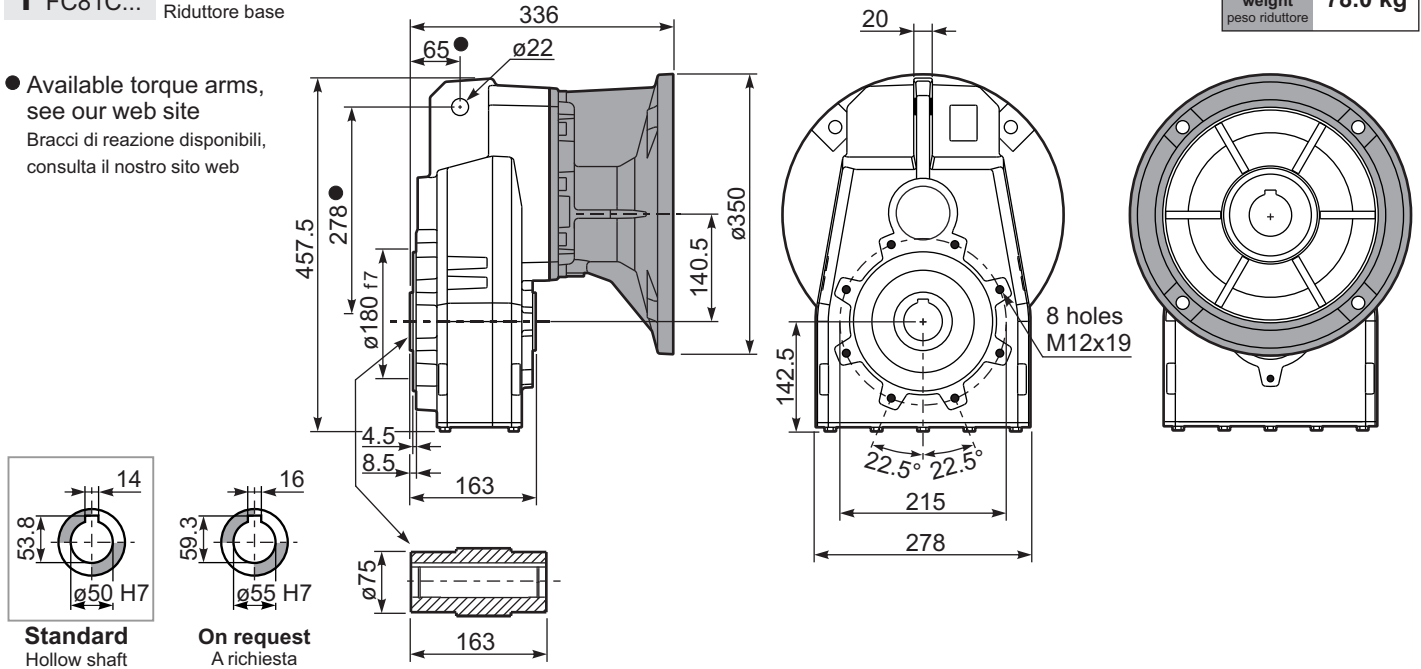

PFC81...-F...

Output flange
Flangia uscita

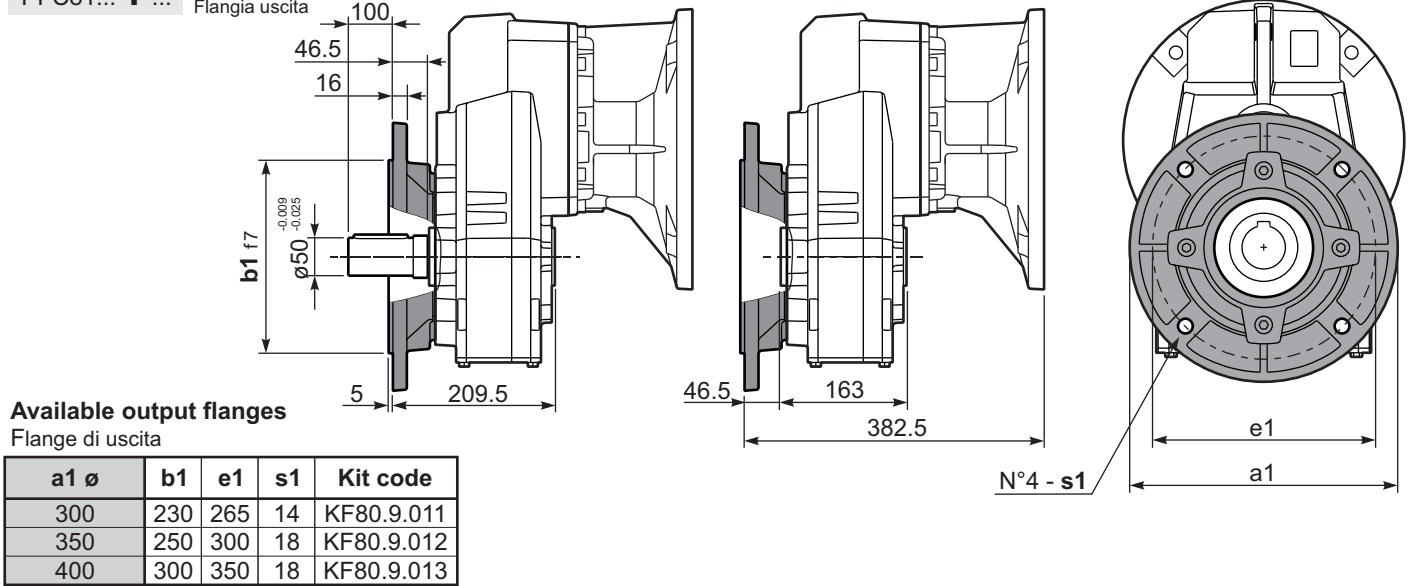

Available output flanges
Flange di uscita

a1 ø	b1	e1	s1	Kit code
300	230	265	14	KF80.9.011
350	250	300	18	KF80.9.012
400	300	350	18	KF80.9.013

PFC81A...

Single output shaft
Albero uscita semplice

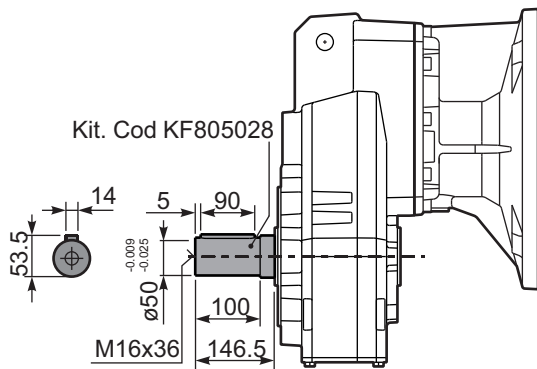



QUICK SELECTION / Selezione veloce

input speed (n_1) = 1400 min⁻¹

Output Speed n_2 [min ⁻¹]	Ratio i	Motor power P_{1M} [kW]	Output torque M_{2M} [Nm]	Service factor f.s.	Nominal power P_{1R} [kW]	Nominal torque M_{2R} [Nm]	B5 motor flanges				B14 motor flanges				Output Shaft 	Ratios code
							F	G	H	I	-	-	-	-		
							100	132	160	180	-	-	-	-		
234	5.98	22	827	1.2	25.5	1000	B							3015	01	
197	7.10	22	982	1.2	25.3	1175	B							3013	02	
162	8.63	22	1193	1.1	23.9	1350	B							3011	03	
124	11.27	18.5	1310	1.1	20.3	1500	B							2015	04	
105	13.38	18.5	1555	1.1	19.4	1700	B							2013	05	
92	15.24	18.5	1771	1.1	19.0	1900	B							1615	06	
86	16.26	18.5	1889	1.1	19.7	2100	B							2011	07	
77	18.09	18.5	2102	1.0	17.7	2100	B							1613	08	
71	19.82	15	1865	1.1	15.9	2060	B							1315	09	
64	21.98	15	2069	1.0	14.6	2100	B							1611	10	
60	23.53	15	2214	0.9	13.6	2100	B							1313	11	
58	24.25	11	1677	1.2	12.2	1940	B							1115	12	
48.6	28.80	11	1991	1.1	11.1	2100	B							1113	13	
40.0	34.99	9	2063	1.0	9.2	2100	B							1111	14	
33.6	41.64	7.5	1976	1.0	7.2	1960	B							813	15	
27.7	50.60	5.5	1774	1.2	6.3	2100	B							811	16	

The dynamic efficiency is **0.96** for all ratios

- Motor Flanges Available
Flange Motore Disponibili
- Supplied with Reduction Bushing
Fornito con Bussola di Riduzione
- Available on Request without reduction bushing
Disponibile a Richiesta senza Bussola di Riduzione
- Motor Flange Holes Position
Posizione Fori Flangia Motore

EN Unit **FC82** is supplied without lubricant and equipped with a breather, level and drain plugs. User can add mineral oil keeping existing plugs. Should the user wish to fill it with synthetic oil, it is recommended to replace the existing plugs with a closed plug.
See table 1 for lubrication and recommended quantity. In table 2 please see possible radial loads and axial loads on the gearbox.

I Il riduttore tipo **FC82** è fornito privo di lubrificazione con tappi di sfiato, livello e scarico olio. L'utente può immettere olio minerale mantenendo i tappi esistenti. Se immetterà olio sintetico, dovrà sostituire i tappi esistenti con altri tipo chiuso.
Tab.1 per oli e quantità consigliati.
Tab.2 carichi radiali e assiali applicabili al riduttore.

D Das Getriebe der Baugröße **FC82** wird ohne Schmiermittel geliefert. Es ist jedoch mit Einfüllschraube, Überdruckventil und Ablassschraube ausgerüstet. Das benötigte mineralische Öl kann über die Einfüllschraube eingefüllt werden. Sollte synthetisches Öl bevorzugt werden, so ist sind das eingebaute Überdruckventil durch eine geschlossenen Schraube zu ersetzen.
In Tabelle 1 ist die Schmiermenge und das empfohlene Schmiermittel angegeben
In Tabelle 2 sind die zulässigen Radial - und Axialbelastungen des Getriebes aufgeführt.

F Le réducteur de type **FC82** est fourni sans lubrification et avec un bouchon de remplissage, de niveau et d'évacuation de l'huile. L'utilisateur peut y verser de l'huile minérale en conservant les bouchons existants. S'il y versera de l'huile synthétique, il devra substituer les bouchons existants avec d'autres bouchons de type fermé.
Voir tableau 1 concernant les huiles et les quantités conseillées.
Voir tableau 2 concernant les charges radiales et axiales applicables au réducteur

E El reductor tamaño **FC82** se suministra sin lubricante, provisto de tapones de respiración, nivel y descarga de aceite. El usuario puede utilizar aceite mineral, manteniendo los tapones existentes. Si prefiere utilizar aceite sintético deberá sustituir los tapones existentes por tapones ciegos. La prerreducción se suministra con tapones ciegos, lubricado de por vida con aceite sintético.
Ver tabla 1, para cantidades y aceites recomendados.
En la tabla 2, se encuentran las cargas radiales y axiales admitidas por el reductor.

H1	H4	H3	H2	H5	H6
5.70 LT	3.60 LT	3.60 LT	3.60 LT	6.60 LT	4.50 LT

AGIP Blasias 460

For all details on lubrication and plugs check our website
Per maggiori dettagli su lubrificazione e tappi olio vedi il nostro sito web **tab. 1**

RADIAL AND AXIAL LOADS

Output shaft
Albero di uscita

$F_{eq} = FR \cdot \frac{227.5}{X+177.5}$

n_2	FA	FR	n_2	FA	FR	n_2	FA	FR
300	920	4600	140	1120	5600	70	1400	7000
250	1000	5000	120	1140	5700	40	1800	9000
200	1060	5300	85	1300	6500	15	2400	12000

On request reinforced bearings to increase loads.
A richiesta cuscinetti rinforzati per aumentare i carichi.

Input shaft
Albero in entrata

n_1	FA	FR
1400	700	3500
900	840	4200
500	900	4500

tab. 2

PFC82C... Basic gearbox
Riduttore base

Gearbox weight **82.5 kg**
peso riduttore

M. flanges	Kit code	øF	A
100/112B5	-	250	337.5
132B5	-	300	341.5
160/180B5	-	350	352.5

● Available torque arms, see our web site
Bracci di reazione disponibili, consulta il nostro sito web

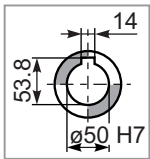

Standard
Hollow shaft

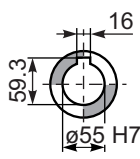

On request
A richiesta

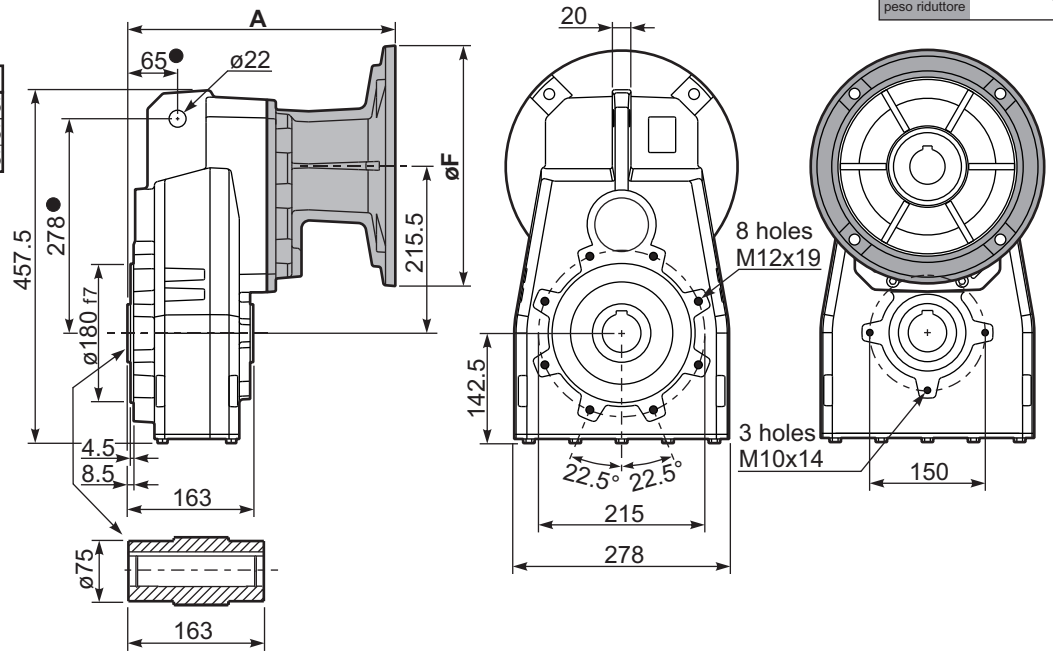

PFC82...-F... Output flange
Flangia uscita

M. flanges	k1
132B5	388
160/180B5	399

Available output flanges
Flange di uscita

a1 ø	b1	e1	s1	Kit code
300	230	265	14	KF80.9.011
350	250	300	18	KF80.9.012
400	300	350	18	KF80.9.013

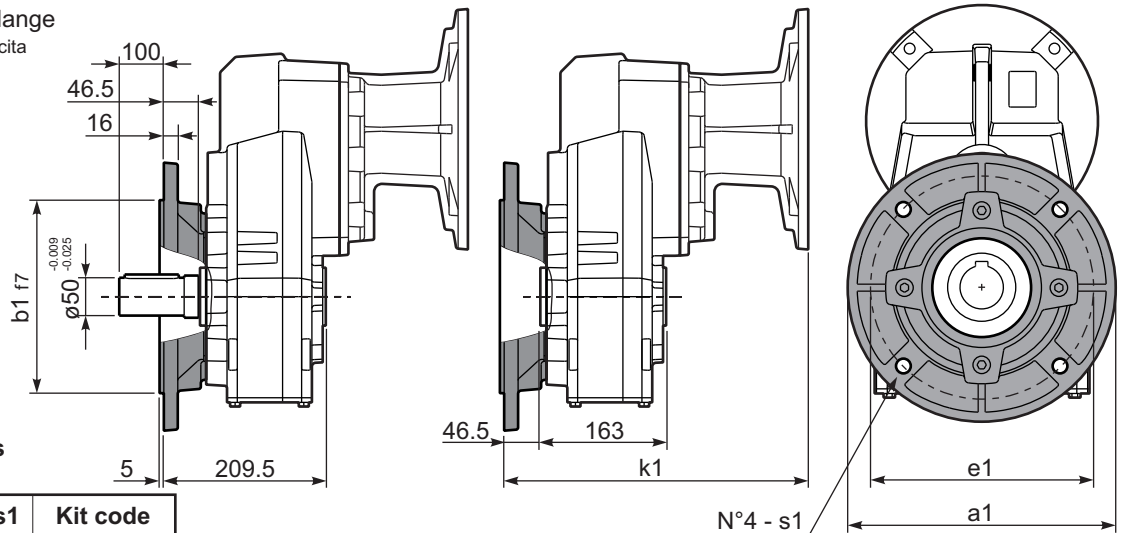

RFC82C... Input Shaft
Albero in entrata

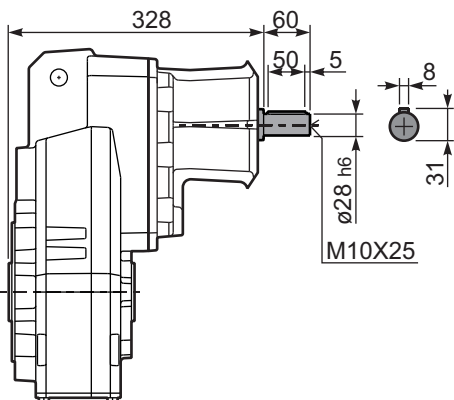

PFC82 A... Single output shaft
Albero uscita semplice

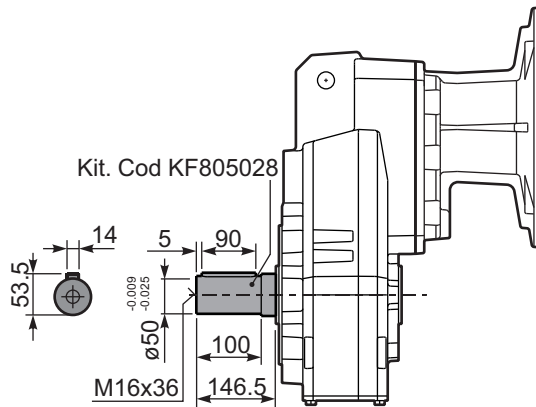

PFC82 D... Shrink disk
Calettatore

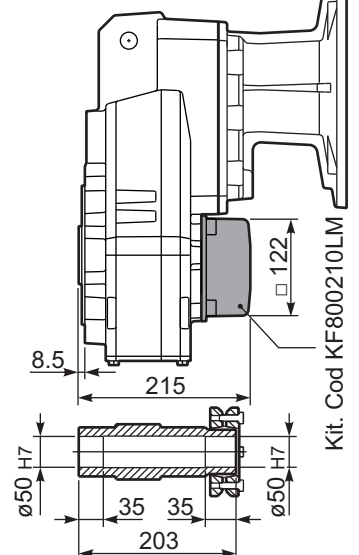



QUICK SELECTION / Selezione veloce

input speed (n_1) = 1400 min⁻¹

Output Speed n_2 [min ⁻¹]	Ratio i	Motor power P_{1M} [kW]	Output torque M_{2M} [Nm]	Service factor f.s.	Nominal power P_{1R} [kW]	Nominal torque M_{2R} [Nm]	Available B5 motor flanges					Available B14 motor flanges				Output Shaft 	Ratios code	
							C	D	E	F	G	R	T	U	V			
							71	80	90	100 112	132	80	90	100 112	132			
28.8	48.55	7.5	2257	0.9	6.7	2100	B										201315	01
24.3	57.64	5.5	1980	1.1	5.7	2100	B										201313	02
21.3	65.64	5.5	2255	0.9	5.0	2100	B										161315	03
20.0	70.04	4	1760	1.2	4.7	2100	B										201311	04
18.0	77.93	4	1958	1.1	4.2	2100	B										161313	05
16.4	85.36	4	2145	1.0	3.8	2100	B										131315	06
14.8	94.70	4	2380	0.9	3.5	2100	B										161311	07
13.8	101.35	3	1917	1.1	3.2	2100	B										131313	08
11.4	123.15	3	2330	0.9	2.7	2100	B										131311	09
9.3	150.73	2.2	2100	1.0	2.2	2100	B										111311	10
7.8	179.39	1.5	1722	1.2	1.8	2100	B										81313	11
6.4	217.98	1.5	2093	1.0	1.5	2100	B										81311	12
5.7	247.03	1.1	1732	1.1	1.2	1950	B										61313	13
4.7	300.17	1.1	2105	1.0	1.1	2100	B										61311	14

The dynamic efficiency is **0.94** for all ratios

- Motor Flanges Available
Flange Motore Disponibili
- Supplied with Reduction Bushing
Fornito con Bussola di Riduzione
- Available on Request without reduction bushing
Disponibile a Richiesta senza Bussola di Riduzione
- Motor Flange Holes Position
Posizione Fori Flangia Motore

EN Unit FC83 is supplied without lubricant and equipped with a breather, level and drain plugs. User can add mineral oil keeping existing plugs. Should the user wish to fill it with synthetic oil, it is recommended to replace the existing plugs with a closed plug.
See table 1 for lubrication and recommended quantity. In table 2 please see possible radial loads and axial loads on the gearbox.

I Il riduttore tipo FC83 è fornito privo di lubrificazione con tappi di sfiato, livello e scarico olio. L'utente può immettere olio minerale mantenendo i tappi esistenti. Se immetterà olio sintetico, dovrà sostituire i tappi esistenti con altri tipo chiuso.
Tab.1 per oli e quantità consigliati.
Tab.2 carichi radiali e assiali applicabili al riduttore.

D Das Getriebe der Baugröße FC83 wird ohne Schmiermittel geliefert. Es ist jedoch mit Einfüllschraube, Überdruckventil und Ablassschraube ausgerüstet. Das benötigte mineralische Öl kann über die Einfüllschraube eingefüllt werden. Sollte synthetisches Öl bevorzugt werden, so ist sind das eingebaute Überdruckventil durch eine geschlossenen Schraube zu ersetzen.
In Tabelle 1 ist die Schmiermenge und das empfohlene Schmiermittel angegeben
In Tabelle 2 sind die zulässigen Radial - und Axialbelastungen des Getriebes aufgeführt.

F Le réducteur de type FC83 est fourni sans lubrification et avec un bouchon de remplissage, de niveau et d'évacuation de l'huile. L'utilisateur peut y verser de l'huile minérale en conservant les bouchons existants. S'il y versera de l'huile synthétique, il devra substituer les bouchons existants avec d'autres bouchons de type fermé.
Voir tableau 1 concernant les huiles et les quantités conseillées.
Voir tableau 2 concernant les charges radiales et axiales applicables au réducteur

E El reductor tamaño FC83 se suministra sin lubricante, provisto de tapones de respiración, nivel y descarga de aceite. El usuario puede utilizar aceite mineral, manteniendo los tapones existentes. Si prefiere utilizar aceite sintético deberá sustituir los tapones existentes por tapones ciegos. La prerreducción se suministra con tapones ciegos, lubricado de por vida con aceite sintético. Ver tabla 1, para cantidades y aceites recomendados. En la tabla 2, se encuentran las cargas radiales y axiales admitidas por el reductor.

H1	H4	H3	H2	H5	H6
5.80 LT	3.90 LT	3.90 LT	3.90 LT	6.80 LT	4.90 LT

AGIP Blasias 460

For all details on lubrication and plugs check our website [tab. 1](#)
Per maggiori dettagli su lubrificazione e tappi olio vedi il nostro sito web

RADIAL AND AXIAL LOADS

Output shaft
Albero di uscita

$F_R(N)$
 $F_A(N)$

$F_{eq} = F_R \cdot \frac{227.5}{X+177.5}$

$F_{eq}(N)$

n_2	FA	FR	n_2	FA	FR	n_2	FA	FR
300	920	4600	140	1120	5600	70	1400	7000
250	1000	5000	120	1140	5700	40	1800	9000
200	1060	5300	85	1300	6500	15	2400	12000

On request reinforced bearings to increase loads.
A richiesta cuscinetti rinforzati per aumentare i carichi.

Input shaft
Albero in entrata

$F_R(N)$
 $F_A(N)$

n_1	FA	FR
1400	450	2250
900	500	2500
500	600	3000

tab. 2

PFC83C...

Basic gearbox
Riduttore base

Gearbox weight **68.5 kg**
peso riduttore

M. flanges	Kit code	øF	A
71B5	KC023.4.041	160	292.5
80/90B5	KC023.4.042	200	294.5
100/112B5	KC023.4.043	250	303.5
132B5	KC50.4.043	300	321.5
80B14	KC085.4.046	120	294.5
90B14	KC085.4.045	140	294.5
100/112B14	KC085.4.047	160	303.5
132B14	KC50.4.041	200	321.5

● Available torque arms, see our web site
Bracci di reazione disponibili, consulta il nostro sito web

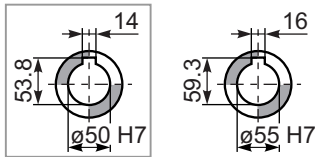

Standard
Hollow shaft

On request
A richiesta

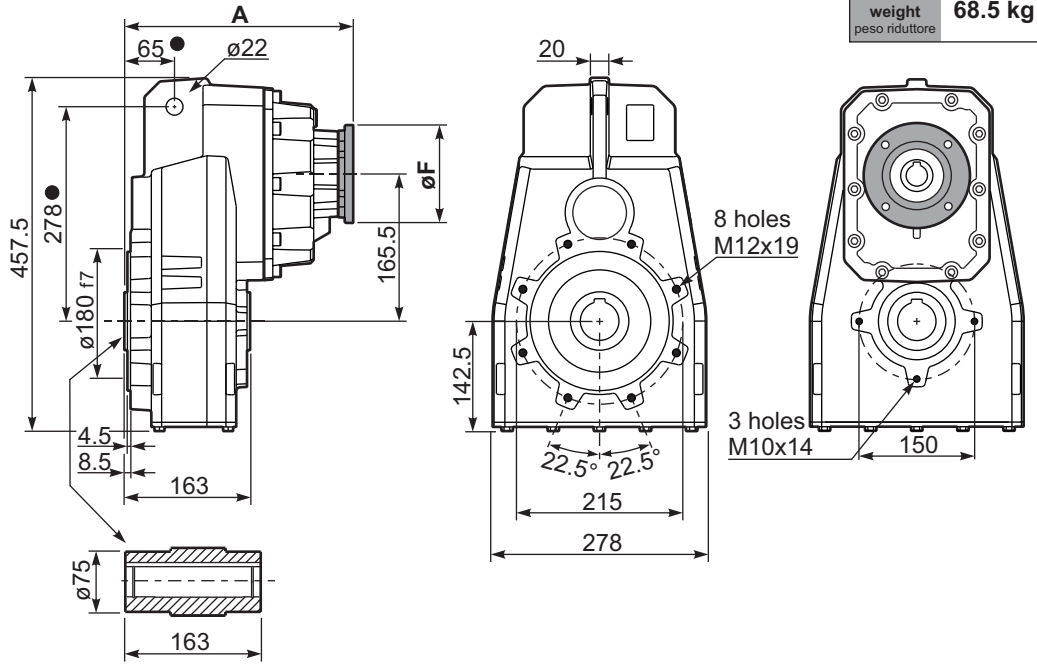

PFC83...-F...

Output flange
Flangia uscita

M. flanges	k1
71B5	339
80/90B5	341
100/112B5	347
132B5	368.5
80B14	339
90B14	339
100/112B14	350
132B14	368.5

Available output flanges
Flange di uscita

a1 ø	b1	e1	s1	Kit code
300	230	265	14	KF80.9.011
350	250	300	18	KF80.9.012
400	300	350	18	KF80.9.013

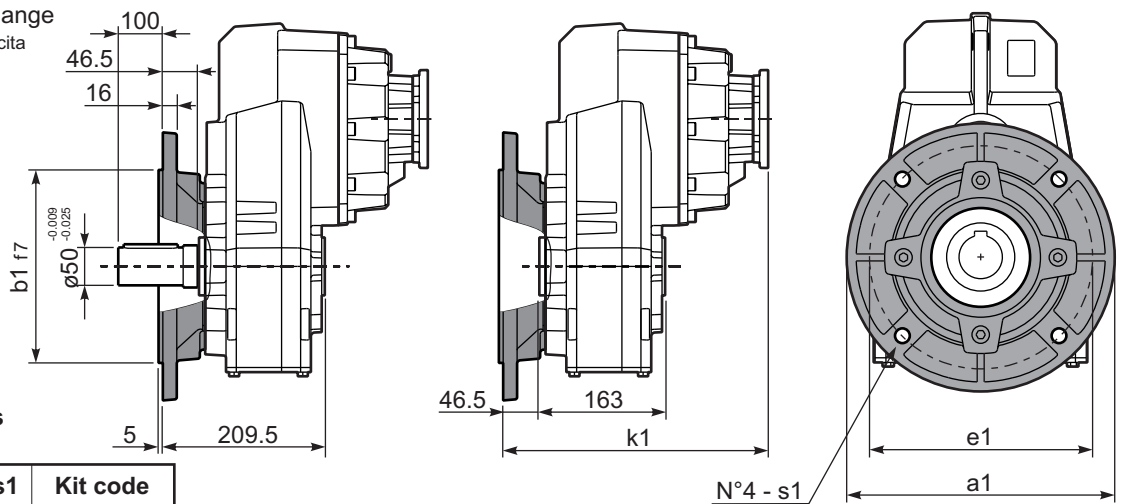

RFC83C...

Input Shaft
Albero in entrata

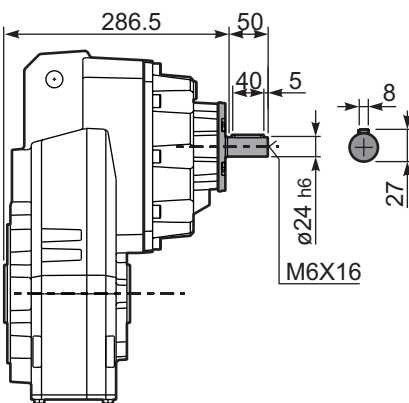

PFC83 A...

Single output shaft
Albero uscita semplice

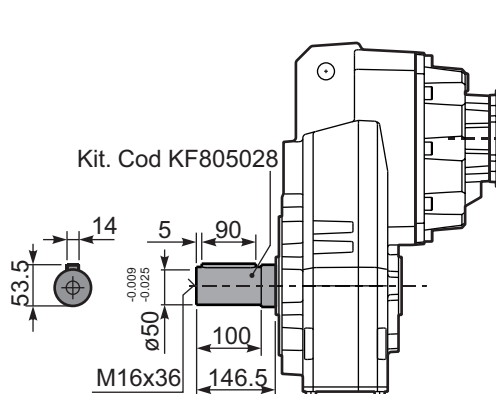

PFC83D...

Shrink disk
Calettatore

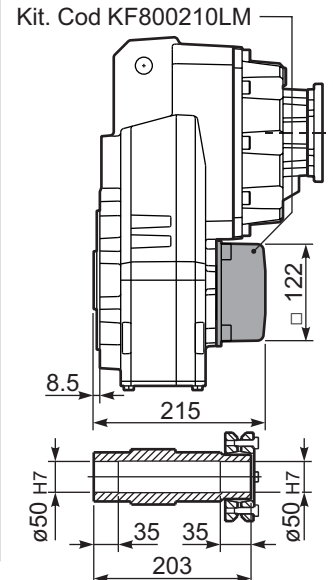



QUICK SELECTION / Selezione veloce

input speed (n_1) = 1400 min⁻¹

Output Speed n_2 [min ⁻¹]	Ratio i	Motor power P_{1M} [kW]	Output torque M_{2M} [Nm]	Service factor f.s.	Nominal power P_{1R} [kW]	Nominal torque M_{2R} [Nm]	Available B5 motor flanges		Available B14 motor flanges			Output Shaft 	Ratios code	
							B	C	O	P	Q			
							63	71	56	63	71			
29.3	47.70	1.1	334	1.4	1.6	480			C	C		281316	standard ø30 On request ø35	01
16.2	86.27	0.75	415	1.2	0.87	480			C	C		191316		02
14.0	100.00	0.75	481	1.0	0.75	480			C	C		171316		03
11.9	117.38	0.55	416	1.2	0.64	480			C	C		151316		04
10.0	140.10	0.55	497	1.0	0.53	480			C	C		131316		05
7.3	191.24	0.37	454	1.1	0.39	480			C	C		101316		06
5.6	249.59	0.25	399	1.2	0.30	480			C	C		91316		07
4.2	329.58	0.25	527	0.9	0.23	480			C	C		71316		08

The dynamic efficiency is **0.94** for all ratios

A Motor Flanges Available
Flange Motore Disponibili

B Supplied with Reduction Bushing
Fornito con Bussola di Riduzione

B Available on Request without reduction bushing
Disponibile a Richiesta senza Bussola di Riduzione



C Motor Flange Holes Position
Posizione Fori Flangia Motore

EN Unit **FS50** is supplied with synthetic oil for lifetime lubrication, no maintenance is necessary. See table 1 for lubrication and recommended quantity. In table 2 please see possible radial loads and axial loads on the gearbox.

I Il riduttore **FS50** viene fornito completo di olio sintetico per la lubrificazione permanente e non necessita di alcuna manutenzione. Vedi tab.1 per oli e quantità consigliati. In tab.2 sono presenti i carichi radiali e assiali applicabili al riduttore.

D Das Getriebe **FS50** ist mit synthetischem Öl gefüllt und ist lebensdauergeschmiert. In Tabelle 1 ist die Schmiermenge und das empfohlene Schmiermittel angegeben. In Tabelle 2 sind die zulässigen Radial- und Axialbelastungen des Getriebes aufgeführt.

F Le réducteur **FS50** est fourni complet avec de l'huile synthétique pour la lubrification permanente et ne nécessite aucun entretien. Voir tableau 1 concernant les huiles et les quantités conseillées. Les charges radiales et axiales applicables au réducteur sont précisées dans le tableau 2.

E El reductor tamaño **FS50** se suministra, lubricado de por vida con aceite sintético y no requieren mantenimiento alguna. Ver tabla 1, para cantidades y aceites recomendados. En la tabla 2, se encuentran las cargas radiales y axiales admitidas por el reductor.

Standard supplied	For these mounting position specify in the order or add oil Per queste posizioni specificare in fase d'ordine o aggiungere olio				
H1	H4	H3	H2	H5	H6
0.95 LT	0.50 LT	0.50 LT	0.70 LT	0.95 LT	0.95 LT
AGIP Telium VSF 320			SHELL Omala S4 WE 320		

For all details on lubrication and plugs check our website **tab. 1**
Per maggiori dettagli su lubrificazione e tappi olio vedi il nostro sito web

RADIAL AND AXIAL LOADS

Input shaft Albero in entrata	F_R (N)	F_A (N)	n_1	FA	FR
	↓ F_R (N)	← F_A (N) SX DX (*)	1400	140	700
			900	160	800

*Strong axial loads in the DX direction are not allowed.
Non sono consentiti forti carichi assiali con direzione DX

tab. 2

Compact gear 480Nm FS50

PFS50C... Basic gearbox
Riduttore base

Gearbox weight
peso riduttore **11.5 kg**

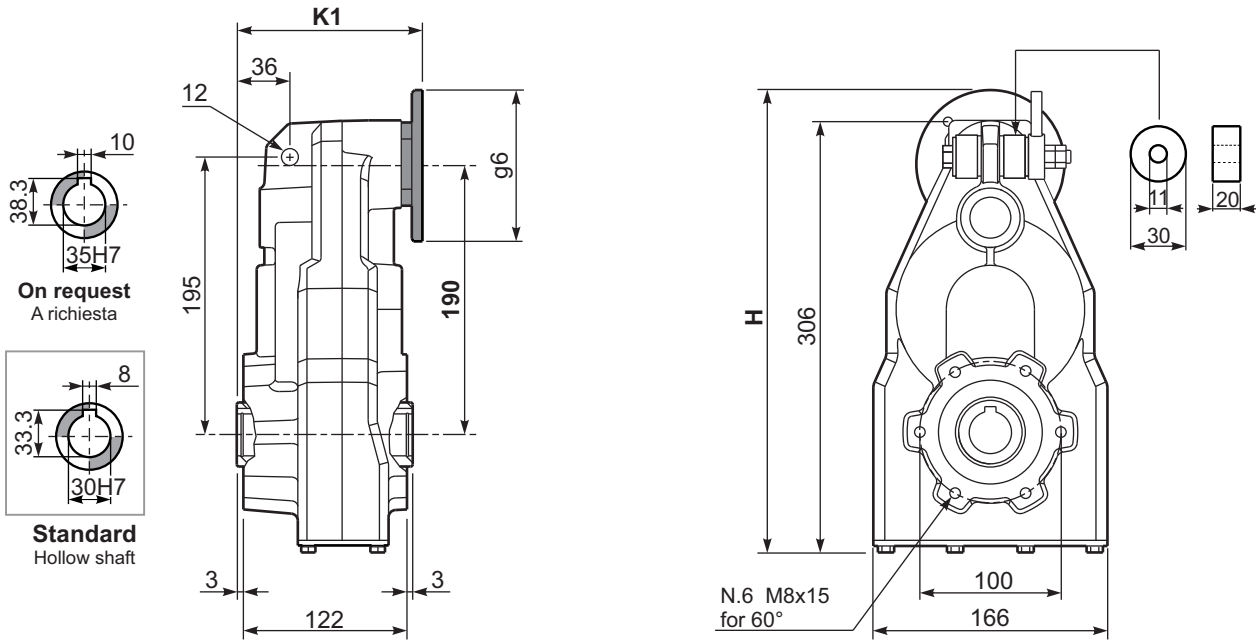

B14 Motor Flanges	H	g6	k1	kit code
56 B14	314	80	130.5	KC40.4.049
63 B14	320	90	133	K050.4.047
71 B14	328	105	130.5	K050.4.045

B5 Motor Flanges	H	g6	k1	kit code
63 B5	345	140	133	K050.4.041
71 B5	355	160	130.5	K050.4.042

RFS50C... Input shaft
Albero in entrata

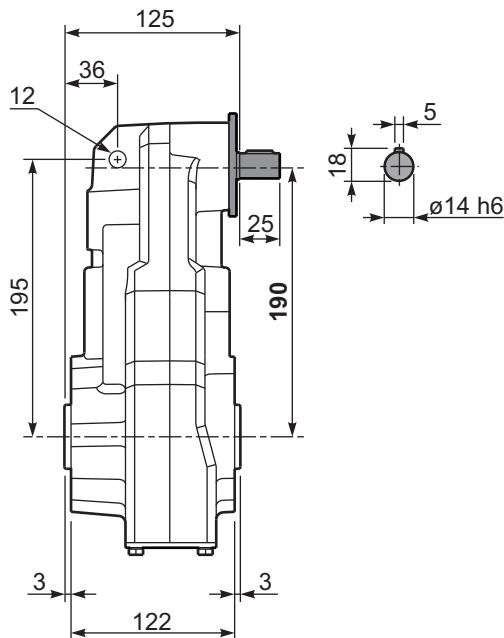

Aluminum and cast iron helical bevel gearbox

A modular and compact product
Very energy efficient drive

Removable inspection cover

Allows periodic inspection of gearing during routine maintenance

Gears

Hardened and ground gears

Alloy housing

Is vacuum impregnated (MIL-STD 276) for protection and sealing. No secondary finish required but readily accepts paint.

Oil seals

Two oil seals on request

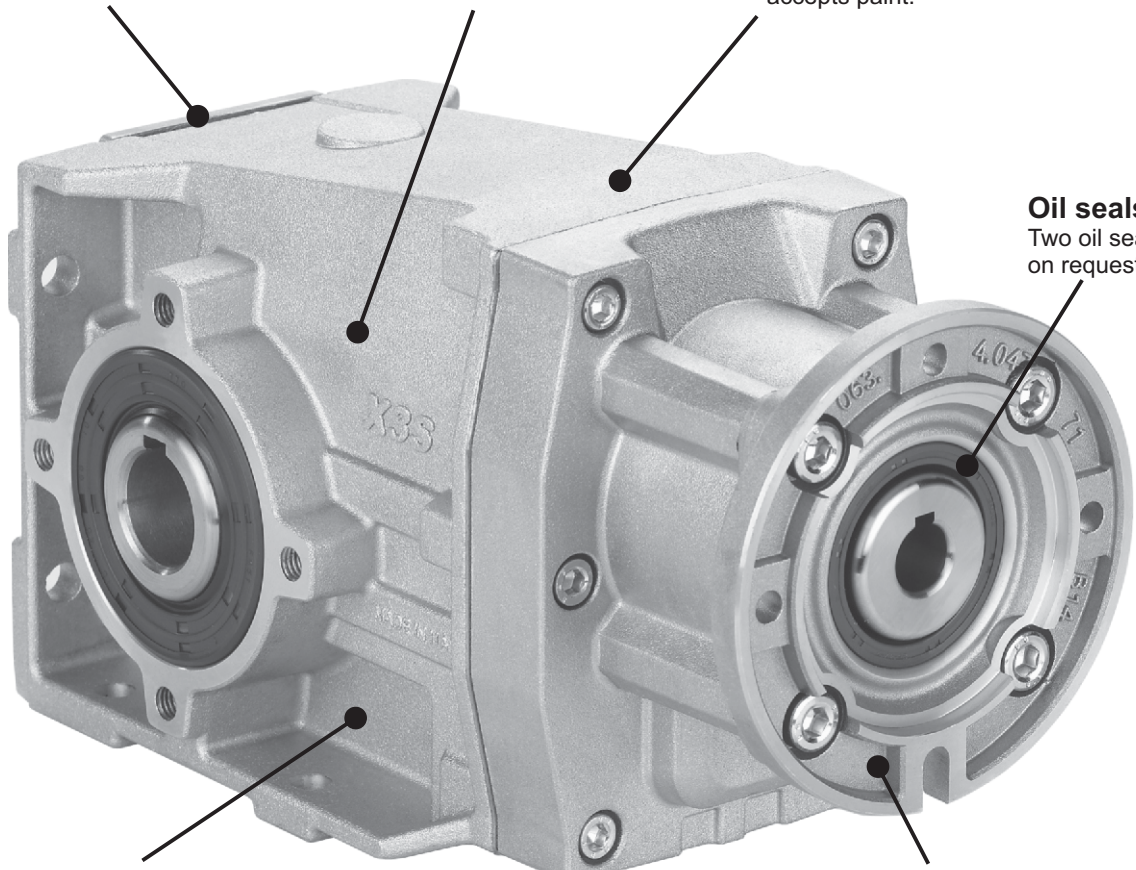

Single-piece aluminum

Combines light weight with high tensile strength. Precision machined for alignment of bearings and gearing

Flange

Fully modular to IEC and Compact integrated motor. NEMA C flange

Cast Iron housing

With high tensile strength. Precision machined for alignment of bearings and gearing

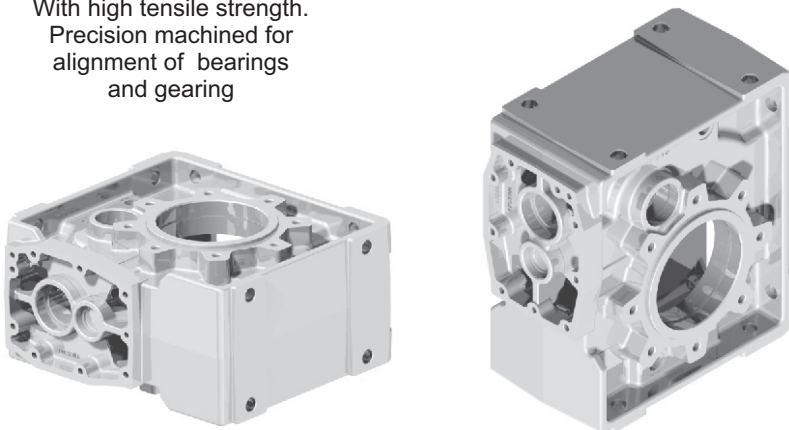

World wide sales network.

Specific type datasheet on page...

On page / A pagina / Auf Seite / À la page / En la página

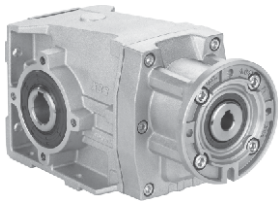

Types / Tipi
Typen / Types
Tipos

8-5	8-7	8-9	8-11	8-13	8-15	8-17	8-19	8-21
X22S 50Nm	X32S 90Nm	X33S 100Nm	X42A 150Nm	X43A 160Nm	X52A 250Nm	X53A 250Nm	X62A 410Nm	X63A 410Nm

On page / A pagina / Auf Seite / À la page / En la página

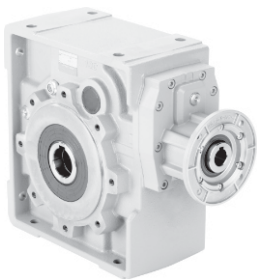

Types / Tipi
Typen / Types
Tipos

8-23	8-25	8-27	8-29	8-31	8-33
113C 675Nm	114C 675Nm	133C 1000Nm	134C 1000Nm	X93C 1600Nm	X94C 1650Nm

On page / A pagina / Auf Seite / À la page / En la página

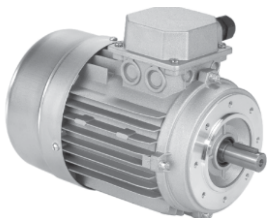





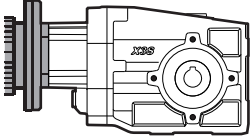
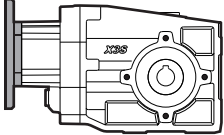
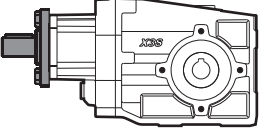
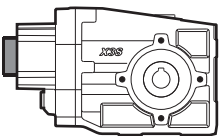
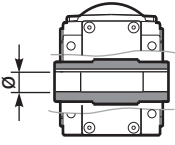
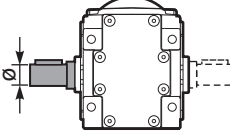
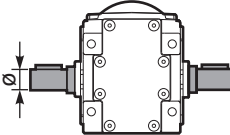
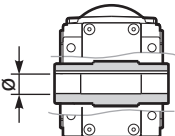
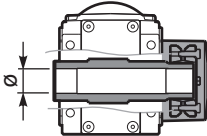

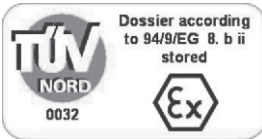

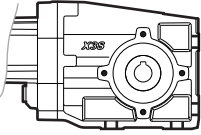
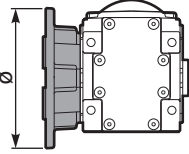

Types / Tipi
Typen / Types
Tipos

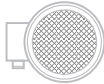
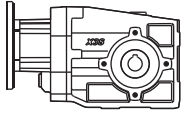
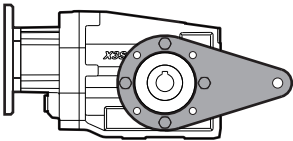
M-1									
56A 56B	63A 63B	71A 71B	80A 80B	90S 90L	100LA 100LB	112M	132S 132M	160M 160L	180M 180L

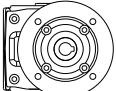
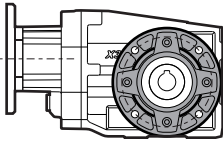
Type - Tipo - Typ Type - Tipo	Size - Grandezza - Größe Taille - Tomaño	Mounting - Montaggio Montage - Fixation Tipo de montaje	Rapporto - Ratio Untersetzung Reduction Relacion	Output shaft - Albero uscita Ausgangsflansch Arbre de sortie Brida en solida																																																																
M	X22S	C	4.83	A																																																																
<p>Helical-bevel gear Riduttori ortogonali</p>  <p>With IEC motor M</p>  <p>With motor flange P</p>  <p>With male input shaft R</p>  <p>Modular base B</p>	<p>2 Stages Riduzioni Stufen Trains Etapas</p> <p>3 Stages Riduzioni Stufen Trains Etapas</p> <p>Aluminum Alluminio Aluminium Aluminio</p> <p>X22S X32S X42A X52A X62A</p> <p>X33S X43A X53A X63A</p> <p>3 Stages Riduzioni Stufen Trains Etapas</p> <p>4 Stages Riduzioni Stufen Trains Etapas</p> <p>Cast Iron Ghisa Grauguss Fonte Fundicion</p> <p>113C 133C X93C</p> <p>114C 134C X94C</p>	<p>Hollow output shaft C</p>  <p>Single output shaft A</p>  <p>Double output shaft only for 113/4C, 133/4C and X93/4C B</p>  <p>Shrink Disk (only on the DX side) D</p> <p>Only on request for Q.ty A richiesta per quantità</p>  <p>Stainless steel hub I</p> <p>Stainless steel hub Mozzo in acciaio Inox Edelstahlhohlwelle Moyeu en acier Inox Nucleo corona de acero Inox</p> <p>Only on request for Q.ty A richiesta per quantità</p>	<p>See technical data table</p> <p>Vedi tabella dati tecnici.</p> <p>Technisches Datenblatt beachten</p> <p>Voir Tableau données techniques</p> <p>Ver tabla datos técnicos</p>	<p>STANDARD</p> <p>Hollow output shaft</p> <table border="1"> <tr> <td>X22S</td> <td>113C 114C</td> </tr> <tr> <td>A ⇨ $\varnothing 18$</td> <td>F ⇨ $\varnothing 40$</td> </tr> <tr> <td>B ⇨ $\varnothing 20$</td> <td>G ⇨ $\varnothing 42$</td> </tr> <tr> <td>X32S X33S</td> <td>133C 134C</td> </tr> <tr> <td>B ⇨ $\varnothing 20$</td> <td>F ⇨ $\varnothing 40$</td> </tr> <tr> <td>C ⇨ $\varnothing 25$</td> <td>H ⇨ $\varnothing 45$</td> </tr> <tr> <td>X42A X43A</td> <td>X93C X94C</td> </tr> <tr> <td>C ⇨ $\varnothing 25$</td> <td>H ⇨ $\varnothing 45$</td> </tr> <tr> <td>D ⇨ $\varnothing 30$</td> <td>J ⇨ $\varnothing 50$</td> </tr> <tr> <td>X52A X53A</td> <td></td> </tr> <tr> <td>D ⇨ $\varnothing 30$</td> <td></td> </tr> <tr> <td>E ⇨ $\varnothing 35$</td> <td></td> </tr> <tr> <td>X62A X63A</td> <td></td> </tr> <tr> <td>E ⇨ $\varnothing 35$</td> <td></td> </tr> <tr> <td>F ⇨ $\varnothing 40$</td> <td></td> </tr> </table> <p>Single and double output shaft</p> <table border="1"> <tr> <td>I</td> <td>X22S ⇨ $\varnothing 20$</td> </tr> <tr> <td>L</td> <td>X32/3S ⇨ $\varnothing 25$</td> </tr> <tr> <td>M</td> <td>X42/3A ⇨ $\varnothing 25$</td> </tr> <tr> <td>N</td> <td>X52/3A ⇨ $\varnothing 30$</td> </tr> <tr> <td>V</td> <td>X62/3A ⇨ $\varnothing 35$</td> </tr> <tr> <td>O</td> <td>113/4C ⇨ $\varnothing 40$</td> </tr> <tr> <td>P</td> <td>113/4C ⇨ $\varnothing 42$</td> </tr> <tr> <td>1</td> <td>133/4C ⇨ $\varnothing 45$</td> </tr> <tr> <td>1</td> <td>X93/4C ⇨ $\varnothing 50$</td> </tr> </table> <p>Double output shaft is available only for 113/4C, 133/4C and X93/4C</p>  <p>Shrink Disk</p> <table border="1"> <tr> <td>U</td> <td>X22S ⇨ $\varnothing 20$</td> </tr> <tr> <td>Q</td> <td>X32/3S ⇨ $\varnothing 20$</td> </tr> <tr> <td>R</td> <td>X42/3A ⇨ $\varnothing 30$</td> </tr> <tr> <td>S</td> <td>X52/3A ⇨ $\varnothing 35$</td> </tr> <tr> <td>6</td> <td>X62/3A ⇨ $\varnothing 40$</td> </tr> <tr> <td>6</td> <td>113/4C ⇨ $\varnothing 45$</td> </tr> <tr> <td>7</td> <td>133/4C ⇨ $\varnothing 45$</td> </tr> <tr> <td>7</td> <td>X93/4C ⇨ $\varnothing 50$</td> </tr> </table>	X22S	113C 114C	A ⇨ $\varnothing 18$	F ⇨ $\varnothing 40$	B ⇨ $\varnothing 20$	G ⇨ $\varnothing 42$	X32S X33S	133C 134C	B ⇨ $\varnothing 20$	F ⇨ $\varnothing 40$	C ⇨ $\varnothing 25$	H ⇨ $\varnothing 45$	X42A X43A	X93C X94C	C ⇨ $\varnothing 25$	H ⇨ $\varnothing 45$	D ⇨ $\varnothing 30$	J ⇨ $\varnothing 50$	X52A X53A		D ⇨ $\varnothing 30$		E ⇨ $\varnothing 35$		X62A X63A		E ⇨ $\varnothing 35$		F ⇨ $\varnothing 40$		I	X22S ⇨ $\varnothing 20$	L	X32/3S ⇨ $\varnothing 25$	M	X42/3A ⇨ $\varnothing 25$	N	X52/3A ⇨ $\varnothing 30$	V	X62/3A ⇨ $\varnothing 35$	O	113/4C ⇨ $\varnothing 40$	P	113/4C ⇨ $\varnothing 42$	1	133/4C ⇨ $\varnothing 45$	1	X93/4C ⇨ $\varnothing 50$	U	X22S ⇨ $\varnothing 20$	Q	X32/3S ⇨ $\varnothing 20$	R	X42/3A ⇨ $\varnothing 30$	S	X52/3A ⇨ $\varnothing 35$	6	X62/3A ⇨ $\varnothing 40$	6	113/4C ⇨ $\varnothing 45$	7	133/4C ⇨ $\varnothing 45$	7	X93/4C ⇨ $\varnothing 50$
X22S	113C 114C																																																																			
A ⇨ $\varnothing 18$	F ⇨ $\varnothing 40$																																																																			
B ⇨ $\varnothing 20$	G ⇨ $\varnothing 42$																																																																			
X32S X33S	133C 134C																																																																			
B ⇨ $\varnothing 20$	F ⇨ $\varnothing 40$																																																																			
C ⇨ $\varnothing 25$	H ⇨ $\varnothing 45$																																																																			
X42A X43A	X93C X94C																																																																			
C ⇨ $\varnothing 25$	H ⇨ $\varnothing 45$																																																																			
D ⇨ $\varnothing 30$	J ⇨ $\varnothing 50$																																																																			
X52A X53A																																																																				
D ⇨ $\varnothing 30$																																																																				
E ⇨ $\varnothing 35$																																																																				
X62A X63A																																																																				
E ⇨ $\varnothing 35$																																																																				
F ⇨ $\varnothing 40$																																																																				
I	X22S ⇨ $\varnothing 20$																																																																			
L	X32/3S ⇨ $\varnothing 25$																																																																			
M	X42/3A ⇨ $\varnothing 25$																																																																			
N	X52/3A ⇨ $\varnothing 30$																																																																			
V	X62/3A ⇨ $\varnothing 35$																																																																			
O	113/4C ⇨ $\varnothing 40$																																																																			
P	113/4C ⇨ $\varnothing 42$																																																																			
1	133/4C ⇨ $\varnothing 45$																																																																			
1	X93/4C ⇨ $\varnothing 50$																																																																			
U	X22S ⇨ $\varnothing 20$																																																																			
Q	X32/3S ⇨ $\varnothing 20$																																																																			
R	X42/3A ⇨ $\varnothing 30$																																																																			
S	X52/3A ⇨ $\varnothing 35$																																																																			
6	X62/3A ⇨ $\varnothing 40$																																																																			
6	113/4C ⇨ $\varnothing 45$																																																																			
7	133/4C ⇨ $\varnothing 45$																																																																			
7	X93/4C ⇨ $\varnothing 50$																																																																			

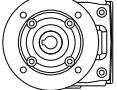

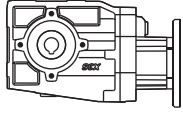
On request we can deliver our products according to the ATEX
 A richiesta possiamo fornire i nostri prodotti secondo le normative ATEX
 Auf Anfrage können wir unsere Produkte den Richtlinien ATEX entsprechend liefern
 Sur demande nos produits peuvent se conformer à la réglementation ATEX
 A pedido, se pueden enviar nuestros productos de acuerdo con las normas ATEX.

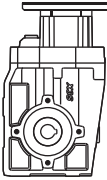
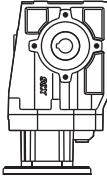
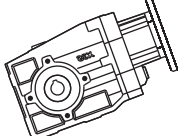
Type - Tipo - Typ Type - Tipo	Output flange - Flangia di uscita Ausgangs Flansch Bride de sortie - Brida en salida	Motor size - Grandezza motore Motor Grösse Grandeur moteur - Tamaño motor	Terminal box position Posizione morsettiere Klemmkastenlage Position boîte à bornes Posición caja de bornes	Mounting position Posizione montaggio Einbaulage Position de montage Posición de montaje																				
BR	N	-O	B	B3																				
 <p>FB Forma base Universal</p>	 <p>N Senza flangia Without flange X22S</p> <p>0 ⇨ Ø110 1 ⇨ Ø120</p> <p>X32S X33S</p> <p>1 ⇨ Ø120 2 ⇨ Ø160</p> <p>X42-3A X52-3A X62-3A</p> <p>2 ⇨ Ø160 3 ⇨ Ø200 4 ⇨ Ø250</p> <p>113C 114C X93C X94C</p> <p>C ⇨ Ø280 L ⇨ Ø280</p> <p>133C 134C</p> <p>C ⇨ Ø320</p>	<p>Standard motor flange Flangia motore standard</p> 	 <p>A</p>	 <p>B3 STANDARD</p>																				
 <p>BR Braccio di reazione Reaction arm</p>		<table border="1"> <thead> <tr> <th data-bbox="695 488 863 521">B5</th> <th data-bbox="874 488 1042 521">B14</th> </tr> </thead> <tbody> <tr> <td data-bbox="695 533 863 600">-A=56 (Ø120)</td> <td data-bbox="874 533 1042 600">-O=56 (Ø80)</td> </tr> <tr> <td data-bbox="695 600 863 667">-B=63 (Ø140)</td> <td data-bbox="874 600 1042 667">-P=63 (Ø90)</td> </tr> <tr> <td data-bbox="695 667 863 734">-C=71 (Ø160)</td> <td data-bbox="874 667 1042 734">-Q=71 (Ø105)</td> </tr> <tr> <td data-bbox="695 734 863 801">-D=80 (Ø200)</td> <td data-bbox="874 734 1042 801">-R=80 (Ø120)</td> </tr> <tr> <td data-bbox="695 801 863 869">-E=90 (Ø200)</td> <td data-bbox="874 801 1042 869">-T=90 (Ø140)</td> </tr> <tr> <td data-bbox="695 869 863 936">-F=100+112 (Ø250)</td> <td data-bbox="874 869 1042 936">-U=100+112 (Ø160)</td> </tr> <tr> <td data-bbox="695 936 863 1003">-G=132 (Ø300)</td> <td data-bbox="874 936 1042 1003">-V=132 (Ø200)</td> </tr> <tr> <td data-bbox="695 1003 863 1070">-H=160 (Ø350)</td> <td></td> </tr> <tr> <td data-bbox="695 1070 863 1137">-I=180 (Ø350)</td> <td></td> </tr> </tbody> </table>	B5	B14	-A =56 (Ø120)	-O =56 (Ø80)	-B =63 (Ø140)	-P =63 (Ø90)	-C =71 (Ø160)	-Q =71 (Ø105)	-D =80 (Ø200)	-R =80 (Ø120)	-E =90 (Ø200)	-T =90 (Ø140)	-F =100+112 (Ø250)	-U =100+112 (Ø160)	-G =132 (Ø300)	-V =132 (Ø200)	-H =160 (Ø350)		-I =180 (Ø350)		 <p>B STANDARD</p>	 <p>B6</p>
B5	B14																							
-A =56 (Ø120)	-O =56 (Ø80)																							
-B =63 (Ø140)	-P =63 (Ø90)																							
-C =71 (Ø160)	-Q =71 (Ø105)																							
-D =80 (Ø200)	-R =80 (Ø120)																							
-E =90 (Ø200)	-T =90 (Ø140)																							
-F =100+112 (Ø250)	-U =100+112 (Ø160)																							
-G =132 (Ø300)	-V =132 (Ø200)																							
-H =160 (Ø350)																								
-I =180 (Ø350)																								
 <p>-F Flangia uscita output flange</p>		<p>Input shaft type R / Tipo R</p> 	 <p>C</p>	 <p>B7</p>																				
		<table border="1"> <tbody> <tr> <td data-bbox="695 1211 863 1267">X22S X33S X43A</td> <td data-bbox="874 1211 1042 1279">X32S X42A X53A X63A 114C 134C</td> </tr> <tr> <td data-bbox="695 1279 863 1335">-1 ⇨ Ø14</td> <td data-bbox="874 1279 1042 1335">-2 ⇨ Ø19</td> </tr> <tr> <td data-bbox="695 1346 863 1402">X52A X62A 113C 133C X94C</td> <td data-bbox="874 1346 1042 1402">X93C</td> </tr> <tr> <td data-bbox="695 1402 863 1458">-3 ⇨ Ø24</td> <td data-bbox="874 1402 1042 1458">-4 ⇨ Ø28</td> </tr> </tbody> </table>	X22S X33S X43A	X32S X42A X53A X63A 114C 134C	-1 ⇨ Ø14	-2 ⇨ Ø19	X52A X62A 113C 133C X94C	X93C	-3 ⇨ Ø24	-4 ⇨ Ø28	 <p>D</p>	 <p>B8</p>												
X22S X33S X43A	X32S X42A X53A X63A 114C 134C																							
-1 ⇨ Ø14	-2 ⇨ Ø19																							
X52A X62A 113C 133C X94C	X93C																							
-3 ⇨ Ø24	-4 ⇨ Ø28																							
		<p>Input model base bore Foro entrata standard</p> 	 <p>V5</p>																					
		<table border="1"> <tbody> <tr> <td data-bbox="695 1563 863 1619">X22S X33S X43A</td> <td data-bbox="874 1563 1042 1630">X32S X42A X53A X63A 114C 134C</td> </tr> <tr> <td data-bbox="695 1619 863 1675">-Z ⇨ Ø9 (56B5)</td> <td data-bbox="874 1619 1042 1686">-1 ⇨ Ø14 (71B5)</td> </tr> <tr> <td data-bbox="695 1675 863 1731">-0 ⇨ Ø11 (63B5)</td> <td data-bbox="874 1675 1042 1742">-2 ⇨ Ø19 (80B5)</td> </tr> <tr> <td data-bbox="695 1731 863 1787">-1 ⇨ Ø14 (71B5)</td> <td data-bbox="874 1731 1042 1798">-3 ⇨ Ø24 (90B5)</td> </tr> </tbody> </table>	X22S X33S X43A	X32S X42A X53A X63A 114C 134C	-Z ⇨ Ø9 (56B5)	-1 ⇨ Ø14 (71B5)	-0 ⇨ Ø11 (63B5)	-2 ⇨ Ø19 (80B5)	-1 ⇨ Ø14 (71B5)	-3 ⇨ Ø24 (90B5)	 <p>V6</p>													
X22S X33S X43A	X32S X42A X53A X63A 114C 134C																							
-Z ⇨ Ø9 (56B5)	-1 ⇨ Ø14 (71B5)																							
-0 ⇨ Ø11 (63B5)	-2 ⇨ Ø19 (80B5)																							
-1 ⇨ Ø14 (71B5)	-3 ⇨ Ø24 (90B5)																							
		<table border="1"> <tbody> <tr> <td data-bbox="695 1794 863 1850">X52A X62A 113C 133C X94C</td> </tr> <tr> <td data-bbox="695 1850 863 1906">-2 ⇨ Ø19 (80B5)</td> </tr> <tr> <td data-bbox="695 1906 863 1962">-3 ⇨ Ø24 (90B5)</td> </tr> <tr> <td data-bbox="695 1962 863 2018">-4 ⇨ Ø28 (100B5)</td> </tr> </tbody> </table> <p style="text-align: center;">➔ STANDARD</p>	X52A X62A 113C 133C X94C	-2 ⇨ Ø19 (80B5)	-3 ⇨ Ø24 (90B5)	-4 ⇨ Ø28 (100B5)	 <p>V8</p> <p>Specify only for vertical positions</p> <p>Specificare solo per posizione verticale</p>																	
X52A X62A 113C 133C X94C																								
-2 ⇨ Ø19 (80B5)																								
-3 ⇨ Ø24 (90B5)																								
-4 ⇨ Ø28 (100B5)																								

POTENZA RICHIESTA / REQUIRED POWER / ERFORDERLICHE LEISTUNG / PUISSANCE NECESSAIRE / POTENCIA NECESARIA

Lifting / sollevamento / hubantriebe / levage / elevación

$$P \text{ [KW]} = \frac{M \text{ [Kg]} \cdot g \text{ [9.81]} \cdot v \text{ [m / s]}}{1000}$$

Rotation / rotazione / drehung / rotation / rotacion

$$P \text{ [KW]} = \frac{M \text{ [Nm]} \cdot n \text{ [rpm]}}{9550}$$

Linear movement / traslazione / linearbewegung / translation / translacion

$$P \text{ [KW]} = \frac{F \text{ [N]} \cdot v \text{ [m / s]}}{1000}$$

TORQUE / COPPIA / DREHMOMENT / COUPLE / PAR

$$M \text{ [Nm]} = \frac{9550 \cdot P \text{ [KW]}}{n \text{ [rpm]}}$$

$$M \text{ [lb in]} = \frac{63030 \cdot P \text{ [HP]}}{n \text{ [rpm]}}$$

RADIAL LOADS / CARICHI RADIALI / RADIALE - UND AXIALLASTEN / CHARGES RADIALES / CARGA RADIAL Y AXIAL

- Radial load generated by external transmissions keyed onto input and/or output shafts.
- Forza radiale generata da organi di trasmissione calettati sugli alberi di ingresso e/o uscita.
- Belastungen der Antriebs- bzw. Abtriebswellen durch von aussen eingebrachte Radiallasten.
- Charge radiale générée par la transmissions calés sur les entrées et / ou des arbres de sortie
- Cargas radiales, generada por transmisiones externas, aplicadas sobre los ejes de entrada y/o salida

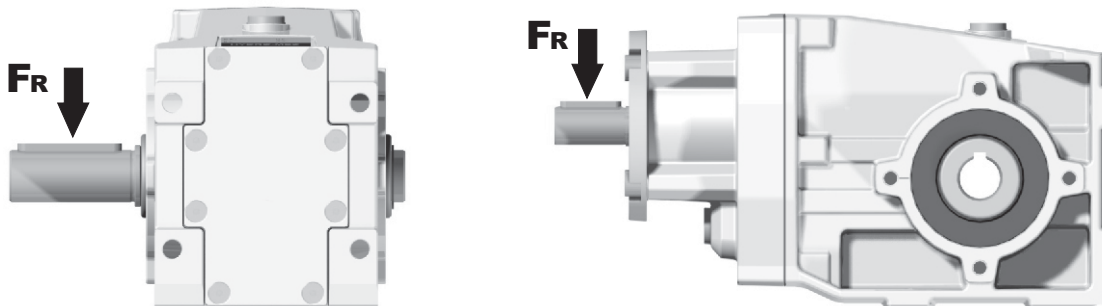

$$F_R \text{ [N]} = \frac{M \text{ [Nm]} \cdot 2000}{d \text{ [mm]}} \cdot f_k$$

$$F_R \text{ [N]} = \frac{M \text{ [lb in]} \cdot 8.9}{d \text{ [in]}} \cdot f_k$$

M	Momento torcente / Output torque / Abtriebsdrehmoment / Couple / Par torsion
d	Diametro primitivo / Diam. of driving element / Durchmesser der Abtriebseinheit / Diamètre primitif / Diámetro primitivo
f_k	Coefficiente di trasformazione / Factor / Faktor / Coefficient de transmission / Coeficiente de transmisión 1.15 Ingranaggi / Gearwheels / Zahnrad / Engrenage / Engranaje 1.25 Catena / Chain sprockets / Antriebskette / Chaîne / Cadena 1.75 Cinghia Trapezoidale / Narrow v-belt pulley / Keilriemen / Courroie trap. / Correa trapezoidal 2.50 Cinghia piatta / Flat-belt pulley / Flachzahnriem. / Courroie crantée / Correa plana

- If your application requires higher radial loads, contact our technical office. Higher load may be possible.
- Nel caso la vostra applicazione richieda carichi radiali superiori consultare il nostro ufficio tecnico, valori maggiori possono essere accettati.
- Wenn Ihre Anwendung höhere Radialbelastungen erfordert, so wenden Sie sich bitte an unser technischen Büro.
- Si votre application demande des charges radiales supérieures, s'adresser à notre bureau technique.
- En el caso en que una aplicación exija una carga radial superior a la especificada en el catálogo, consultar a nuestra oficinas técnica.

How to select a gearbox / Come selezionare un riduttore / Wie wählt man ein Getriebe
Comment sélectionner un réducteur / Cómo seleccionar un reductor

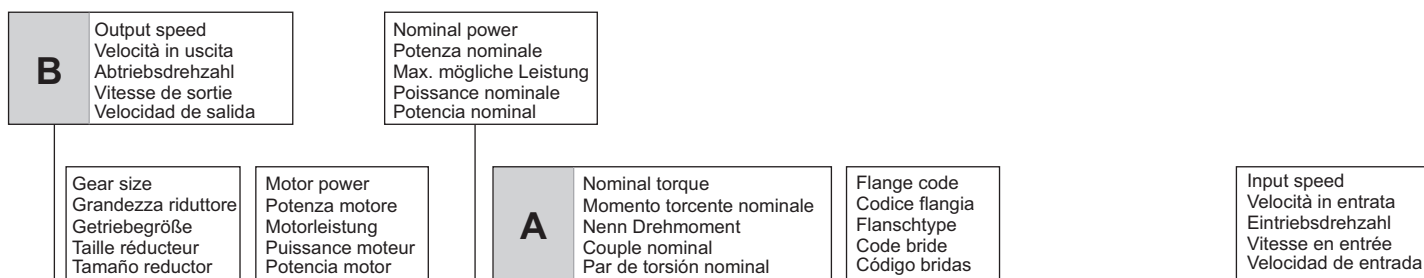

X22S Angletech Gear **50Nm** Rating - Aluminum HELICAL-BEVEL GEARBOXES

QUICK SELECTION / Selezione veloce The dynamic efficiency is **0.96** for all ratios input speed (n_1) = 1400 min⁻¹

Output Speed n_2 [min ⁻¹]	Ratio i	Motor power P_{1M} [kW]	Output torque M_{2M} [Nm]	Service factor $f.s.$	Nominal power P_{1R} [kW]	Nominal torque M_{2R} [Nm]	Available B5 motor flanges		Available B14 motor flanges			Output Shaft 	Ratios code
							B	C	O	P	Q		
289.7	4.83	0.37	11.7	2.6	0.95	30			C	C		289	01
189.2	7.40	0.37	17.9	1.7	0.62	30			C	C		287	02
146.2	9.58	0.37	23.2	1.7	0.64	40			C	C		199	03
127.5	10.98	0.37	26.6	1.7	0.63	45			C	C		179	04



Type of load and starts per hour Tipo di carico e avviamenti per ora		Oper. hours per day Ore di funz. giorn.		
		3 h	10 h	24 h
Continuous or intermittent appl. with start / hour Applicazione cont. o interm. con n.ro operazioni/ora	Uniform / Uniforme	0.8	1	1.25
	Moderate / Moderato	1	1.25	1.5
	Heavy / Forte	1.25	1.5	1.75
Intermittent application with start / hour Applicazione intermittente con n.ro operazioni/ora	Uniform / Uniforme	1	1.25	1.5
	Moderate / Moderato	1.25	1.5	1.75
	Heavy / Forte	1.5	1.75	2.15

D	Motor flange available Flange disponibili Erhältliche Motorflansche Brides disponibles Bridas disponibles	
B)	Mounting with reduction ring Montaggio con boccola di riduzione Reduzierhülsen Montage avec douille de réduction Montaje con casquillo de reducción	
C)	Motor flangeholes position/terminal box position Posizione fori flangia/basetta motore Bohrungsposition am Motorflansch/-sockel Position trous bride/barrette à bornes moteur Posición agujeros brida / base motor	
B)	Available without reduction bushes Disponibile anche senza boccola Auch ohne Reduzierbuchse verfügbar Disponible aussi sans douille de réduction Disponible tambien sin casquillo	

A	Select required torque (according to service factor)	Seleziona la coppia desiderata (comprensiva del fattore di servizio)	Max. Drehmoment in Bezug zum Betriebsfaktor	Sélectionner le couple souhaité (comprenant le facteur de service)	Seleccionar el par deseado (incluyendo el factor de servicio)
B	Select output speed	Seleziona la velocità in uscita	Ausgewählte Abtriebsdrehzahl	Sélectionner la vitesse de sortie	Seleccionar la velocidad de salida
C	On the same line of selected geared motor, you can find the gear ratio	Sulla riga corrispondente alla motorizzazione prescelta si può rilevare il rapporto di riduzione	Auf der gleichen Linie wie die ausgewählte Motorleistung steht auch die Getriebeuntersetzung	Sur la ligne correspondante à la motorisation pré-choisie on peut relever le rapport de réduction	En la línea correspondiente al motor preseleccionado es posible encontrar la relación de reducción
D	Select motor flange available (if requested)	Scegli la flangia disponibile (se richiesta)	Erhältliche Motorflansche (auf Anfrage)	Choisir la bride disponible (si elle est demandée)	Seleccionar la brida disponible (sobre pedido)

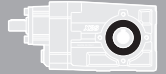

QUICK SELECTION / Selezione veloce The dynamic efficiency is **0.96** for all ratios **input speed (n₁) = 1400 min⁻¹**

Output Speed n ₂ [min ⁻¹]	Ratio i	Motor power P _{1M} [kW]	Output torque M _{2M} [Nm]	Service factor f.s.	Nominal power P _{1R} [kW]	Nominal torque M _{2R} [Nm]	Available B5 motor flanges		Available B14 motor flanges			Output Shaft 	Ratios code	
							B	C	O	P	Q			
							63	71	56	63	71			
290	4.83	0.37	12	2.6	0.95	30			C	C		289	standard ø20	01
189	7.40	0.37	18	1.7	0.62	30			C	C		287		02
146	9.58	0.37	23	1.7	0.64	40			C	C		199		03
128	10.98	0.37	27	1.7	0.63	45			C	C		179		04
107	13.07	0.37	32	1.4	0.53	45			C	C		159		05
95	14.66	0.37	35	1.3	0.47	45			C	C		197		06
89	15.79	0.37	38	1.2	0.44	45			C	C		139		07
83	16.81	0.37	41	1.1	0.41	45			C	C		177		08
70	20.00	0.37	48	1.0	0.37	48			C	C		157		09
64	21.93	0.37	53	0.9	0.35	50			C	C		109		On request
58	24.18	0.25	39	1.3	0.32	50			C	C		137		11
48.2	29.04	0.25	47	1.1	0.26	50			C	C		99		12
41.7	33.57	0.18	42	1.2	0.23	50			C	C		107		13
36.2	38.67	0.18	48	1.0	0.20	50			C	C		79		14
31.5	44.44	0.18	56	0.9	0.17	50			C	C		97		15
23.7	59.18	0.12	48	1.0	0.13	50			C	C		77		16
19.9	70.24	0.09	45	1.1	0.11	50			C	C		67		17

Motor Flanges Available Flange Motore Disponibili B) Supplied with Reduction Bushing Fornito con Bussola di Riduzione B) Available on Request without reduction bushing Disponibile a Richiesta senza Bussola di Riduzione C) Motor Flange Holes Position Posizione Fori Flangia Motore

EN Unit **X22S** is supplied with synthetic oil for lifetime lubrication, no maintenance is necessary. See table 1 for lubrication and recommended quantity. In table 2 please see possible radial loads and axial loads on the gearbox.

I Il riduttore **X22S** viene fornito completo di olio sintetico per la lubrificazione permanente e non necessita di alcuna manutenzione. Vedi tab.1 per oli e quantità consigliati. In tab.2 sono presenti i carichi radiali e assiali applicabili al riduttore.

D Das Getriebe **X22S** ist mit synthetischem Öl gefüllt und ist lebensdauergeschmiert. In Tabelle 1 ist die Schmiermenge und das empfohlene Schmiermittel angegeben. In Tabelle 2 sind die zulässigen Radial - und Axialbelastungen des Getriebes aufgeführt.

F Le réducteur **X22S** est fourni complet avec de l'huile synthétique pour la lubrification permanente et ne nécessite aucun entretien. Voir tableau 1 concernant les huiles et les quantités conseillées. Les charges radiales et axiales applicables au réducteur sont précisées dans le tableau 2.

E El reductor tamaño **X22S** se suministra, lubricado de por vida con aceite sintético y no requieren mantenimiento alguna. Ver tabla 1, para cantidades y aceites recomendados. En la tabla 2, se encuentran las cargas radiales y axiales admitidas por el reductor.

Standard supplied	For these mounting position specify in the order or add oil Per queste posizioni specificare in fase d'ordine o aggiungere olio					
0.25 LT	0.25 LT	0.25 LT	0.25 LT	0.43 LT	0.31 LT	0.25 LT
AGIP Telium VSF 320				SHELL Omala S4 WE 320		

For all details on lubrication and plugs check our website **tab. 1**
Per maggiori dettagli su lubrificazione e tappi olio vedi il nostro sito web

RADIAL AND AXIAL LOADS

Output shaft

Albero di uscita

$$F_{eq} = F_R \cdot \frac{42}{X+23}$$

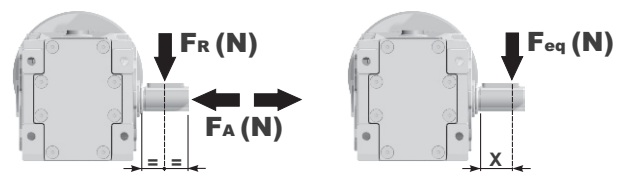

n ₂ [min ⁻¹]	FA	FR	n ₂ [min ⁻¹]	FA	FR	n ₂ [min ⁻¹]	FA	FR
400	360	1800	100	440	2200	25	440	2200
250	380	1900	75	440	2200	15	440	2200
150	420	2100	50	440	2200			

FR On request taper roller bearings to increase radial loads.
A richiesta cuscinetti a rulli conici per aumentare i carichi radiali.

Input shaft

albero in entrata

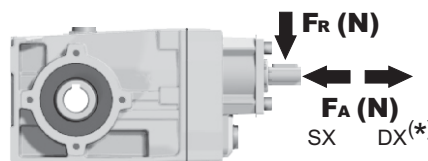

n ₁ [min ⁻¹]	FA	FR
1400	140	700
900	160	800
600	190	950

*Strong axial loads in the DX direction are not allowed.
Non sono consentiti forti carichi assiali con direzione DX

tab. 2

PX22SC... Basic Gearbox
Riduttore base

Gearbox weight
peso riduttore **3.70 kg**

M. flanges	Kit code	øF	A
63B5	K050.4.041	138	154.5
71B5	K050.4.042	160	152
56B14	KC40.4.049	80	152
63B14	K050.4.047	90	154.5
71B14	K050.4.045	105	152

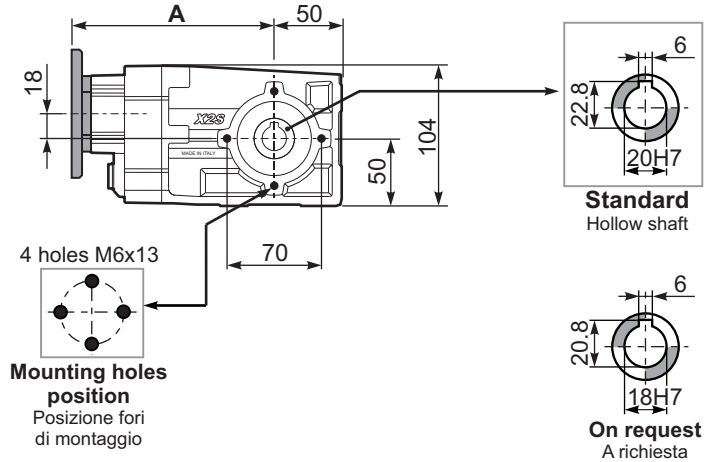
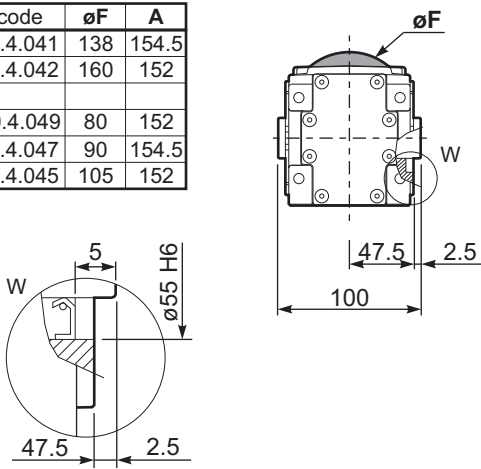

PX22S..-N.. Feet
Piedini

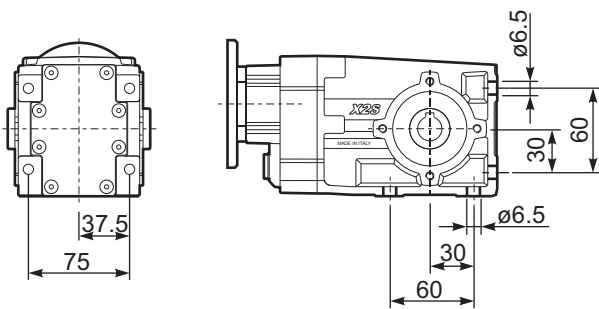

PX22S-F0.. Output flange
Flangia uscita

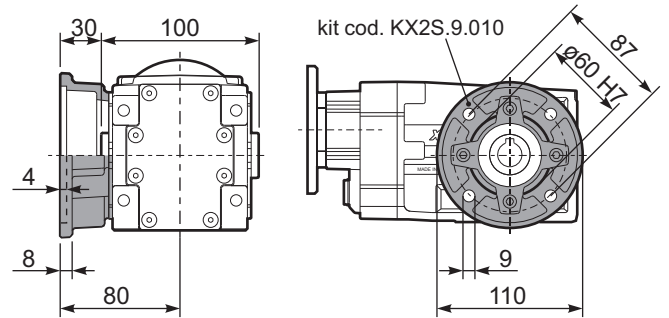

PX22S-F1.. Output flange
Flangia uscita

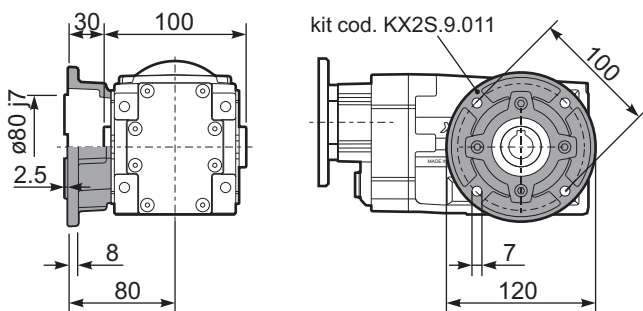

PX22SBR.. Reaction Arm
Braccio di reazione

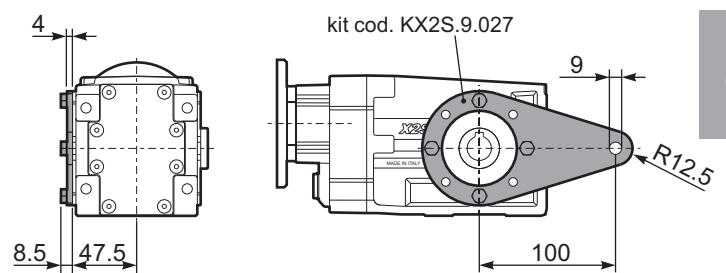

RX22S.. Input shaft
Albero in entrata

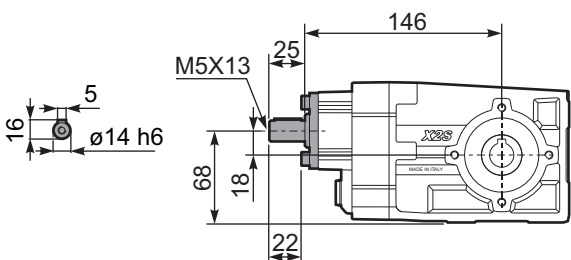

PX22S..A.. Single output shaft
Albero semplice in uscita

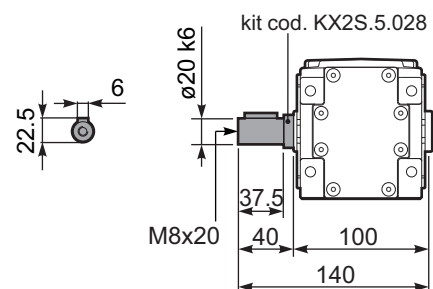

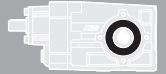

QUICK SELECTION / Selezione veloce The dynamic efficiency is **0.96** for all ratios **input speed (n₁) = 1400 min⁻¹**

Output Speed n ₂ [min ⁻¹]	Ratio i	Motor power P _{1M} [kW]	Output torque M _{2M} [Nm]	Service factor f.s.	Nominal power P _{1R} [kW]	Nominal torque M _{2R} [Nm]	Available B5 motor flanges				Available B14 motor flanges			Output Shaft 	Ratios code		
							B	C	D	E	Q	R	T				
							63	71	80	90	71	80	90				
191	7.33	1.5	72	1.0	1.5	70	B				C	C		289	standard ø20	01	
125	11.22	1.1	80	1.1	1.2	85	B				C	C		287		02	
106	13.26	1.1	95	0.9	0.98	85	B				C	C		199		03	
91	15.37	1.1	110	0.8	0.89	90	B				C	C		179		04	
78	18.04	0.75	89	1.0	0.76	90	B				C	C		159		05	
69	20.30	0.75	100	0.9	0.68	90	B				C	C		197		06	
65	21.54	0.75	106	0.9	0.64	90	B				C	C		139		07	
59	23.53	0.55	85	1.1	0.58	90	B				C	C		177		08	
51	27.62	0.55	100	0.9	0.50	90	B				C	C		157		09	
47.6	29.40	0.55	106	0.8	0.47	90	B				C	C		109		On request	10
42.5	32.97	0.37	80	1.1	0.42	90	B				C	C		137		11	
36.5	38.37	0.37	93	1.0	0.36	90	B				C	C		99		12	
31.1	45.00	0.25	73	1.2	0.31	90	B				C	C		107		13	
27.6	50.67	0.25	83	1.1	0.27	90	B				C	C		79		14	
23.8	58.73	0.18	73	1.2	0.23	90	B				C	C		97		15	
18.1	77.55	0.18	97	0.9	0.18	90	B				C	C		77		16	

Motor Flanges Available Flange Motore Disponibili
 B) Supplied with Reduction Bushing Fornito con Bussola di Riduzione
 B) Available on Request without reduction bushing Disponibile a Richiesta senza Bussola di Riduzione
 C) Motor Flange Holes Position Posizione Fori Flangia Motore

EN Unit **X32S** is supplied with synthetic oil for lifetime lubrication, no maintenance is necessary. See table 1 for lubrication and recommended quantity. In table 2 please see possible radial loads and axial loads on the gearbox.

I Il riduttore **X32S** viene fornito completo di olio sintetico per la lubrificazione permanente e non necessita di alcuna manutenzione. Vedi tab.1 per oli e quantità consigliati. In tab.2 sono presenti i carichi radiali e assiali applicabili al riduttore.

D Das Getriebe **X32S** ist mit synthetischem Öl gefüllt und ist lebensdauer geschmiert. In Tabelle 1 ist die Schmiermenge und das empfohlene Schmiermittel angegeben. In Tabelle 2 sind die zulässigen Radial- und Axialbelastungen des Getriebes aufgeführt.

F Le réducteur **X32S** est fourni complet avec de l'huile synthétique pour la lubrification permanente et ne nécessite aucun entretien. Voir tableau 1 concernant les huiles et les quantités conseillées. Les charges radiales et axiales applicables au réducteur sont précisées dans le tableau 2.

E El reductor tamaño **X32S** se suministra, lubricado de por vida con aceite sintético y no requieren mantenimiento alguna. Ver tabla 1, para cantidades y aceites recomendados. En la tabla 2, se encuentran las cargas radiales y axiales admitidas por el reductor.

Standard supplied	For these mounting position specify in the order or add oil						
	Per queste posizioni specificare in fase d'ordine o aggiungere olio						
0.40 LT	0.60 LT	0.40 LT	0.60 LT	0.85 LT	0.60 LT	0.40 LT	
AGIP Telium VSF 320				SHELL Omala S4 WE 320			

For all details on lubrication and plugs check our website **tab. 1**
Per maggiori dettagli su lubrificazione e tappi olio vedi il nostro sito web

RADIAL AND AXIAL LOADS

Output shaft
Albero di uscita

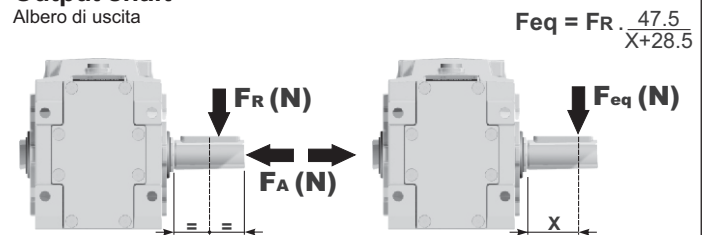

n ₂ [min ⁻¹]	FA	FR	n ₂ [min ⁻¹]	FA	FR	n ₂ [min ⁻¹]	FA	FR
250	400	2000	75	560	2800	15	560	2800
150	450	2250	50	560	2800			
100	500	2500	25	560	2800			

FR On request taper roller bearings to increase radial loads.
A richiesta cuscinetti a rulli conici per aumentare i carichi radiali.

Input shaft
albero in entrata

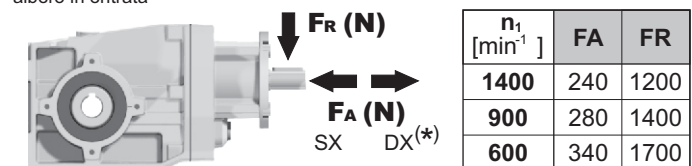

n ₁ [min ⁻¹]	FA	FR
1400	240	1200
900	280	1400
600	340	1700

***Strong axial loads in the DX direction are not allowed.**
Non sono consentiti forti carichi assiali con direzione DX

tab. 2

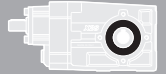

QUICK SELECTION / Selezione veloce The dynamic efficiency is **0.94** for all ratios **input speed (n₁) = 1400 min⁻¹**

Output Speed n ₂ [min ⁻¹]	Ratio i	Motor power P _{1M} [kW]	Output torque M _{2M} [Nm]	Service factor f.s.	Nominal power P _{1R} [kW]	Nominal torque M _{2R} [Nm]	Available B5 motor flanges		Available B14 motor flanges			Output Shaft 	Ratios code
							B	C	O	P	Q		
							63	71	56	63	71		
38.7	36.17	0.37	86	1.2	0.43	100			C	C		17179	01
31.7	44.21	0.37	105	1.0	0.35	100			C	C		19139	02
27.6	50.68	0.25	81	1.2	0.31	100			C	C		17139	03
25.3	55.36	0.25	89	1.1	0.28	100			C	C		17177	04
23.2	60.31	0.25	96	1.0	0.26	100			C	C		15139	05
21.2	65.88	0.25	105	0.9	0.24	100			C	C		15177	06
19.4	72.25	0.18	88	1.1	0.22	100			C	C		10179	07
17.6	79.64	0.18	97	1.0	0.20	100			C	C	standard ø20	13177	08
15.2	92.31	0.18	113	0.9	0.17	100			C	C		15137	09
14.6	95.65	0.18	117	0.9	0.16	100			C	C		9179	10
13.8	101.23	0.12	80	1.2	0.15	100			C	C	ø25	10139	11
11.0	127.37	0.12	101	1.0	0.12	100			C	C	On request	7179	12
9.3	151.16	0.09	95	1.0	0.10	100			C	C		6179	13
7.8	178.46	0.09	113	0.9	0.09	100			C	C		7139	14
6.6	211.79	0.06	88	1.1	0.07	100			C	C		6139	15
6.1	231.37	0.06	96	1.0	0.07	100			C	C		6177	16
5.1	273.16	0.06	113	0.9	0.06	100			C	C		7137	17
4.3	324.18	0.06	134	0.7	0.05	100			C	C		6137	18

Motor Flanges Available Flange Motore Disponibili **B) Supplied with Reduction Bushing** Fornito con Bussola di Riduzione **B) Available on Request without reduction bushing** Disponibile a Richiesta senza Bussola di Riduzione **C) Motor Flange Holes Position** Posizione Fori Flangia Motore

EN Unit **X33S** is supplied with synthetic oil for lifetime lubrication, no maintenance is necessary. See table 1 for lubrication and recommended quantity. In table 2 please see possible radial loads and axial loads on the gearbox.

I Il riduttore **X33S** viene fornito completo di olio sintetico per la lubrificazione permanente e non necessita di alcuna manutenzione. Vedi tab.1 per oli e quantità consigliati. In tab.2 sono presenti i carichi radiali e assiali applicabili al riduttore.

D Das Getriebe **X33S** ist mit synthetischem Öl gefüllt und ist lebensdauergeschmiert. In Tabelle 1 ist die Schmiermenge und das empfohlene Schmiermittel angegeben. In Tabelle 2 sind die zulässigen Radial - und Axialbelastungen des Getriebes aufgeführt.

F Le réducteur **X33S** est fourni complet avec de l'huile synthétique pour la lubrification permanente et ne nécessite aucun entretien. Voir tableau 1 concernant les huiles et les quantités conseillées. Les charges radiales et axiales applicables au réducteur sont précisées dans le tableau 2.

E El reductor tamaño **X33S** se suministra, lubricado de por vida con aceite sintético y no requieren mantenimiento alguna. Ver tabla 1, para cantidades y aceites recomendados. En la tabla 2, se encuentran las cargas radiales y axiales admitidas por el reductor.

Standard supplied	For these mounting position specify in the order or add oil Per queste posizioni specificare in fase d'ordine o aggiungere olio					
0.70 LT	0.65 LT	0.40 LT	0.65 LT	0.95 LT	0.65 LT	0.45 LT
AGIP Telium VSF 320			SHELL Omala S4 WE 320			

For all details on lubrication and plugs check our website **tab. 1**
Per maggiori dettagli su lubrificazione e tappi olio vedi il nostro sito web

RADIAL AND AXIAL LOADS

Output shaft

Albero di uscita

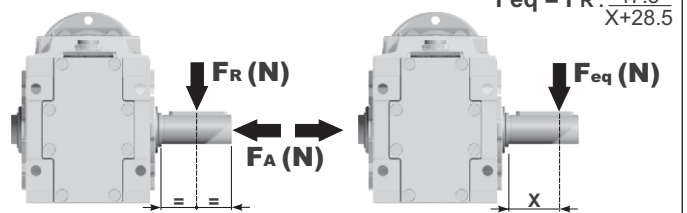

n ₂ [min ⁻¹]	FA	FR	n ₂ [min ⁻¹]	FA	FR	n ₂ [min ⁻¹]	FA	FR
250	400	2000	75	560	2800	15	560	2800
150	450	2250	50	560	2800			
100	500	2500	25	560	2800			

FR On request taper roller bearings to increase radial loads.
A richiesta cuscinetti a rulli conici per aumentare i carichi radiali.

Input shaft

albero in entrata

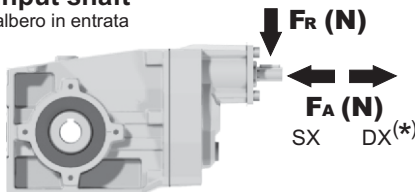

n ₁ [min ⁻¹]	FA	FR
1400	140	700
900	160	800
600	190	950

*Strong axial loads in the DX direction are not allowed.
Non sono consentiti forti carichi assiali con direzione DX

tab. 2

PX33SC... Basic Gearbox
Riduttore base

Gearbox weight
peso riduttore **6.55 kg**

M. flanges	Kit code	øF	A
63B5	K050.4.041	138	189.5
71B5	K050.4.042	160	187
56B14	KC40.4.049	80	187
63B14	K050.4.047	90	189.5
71B14	K050.4.045	105	187

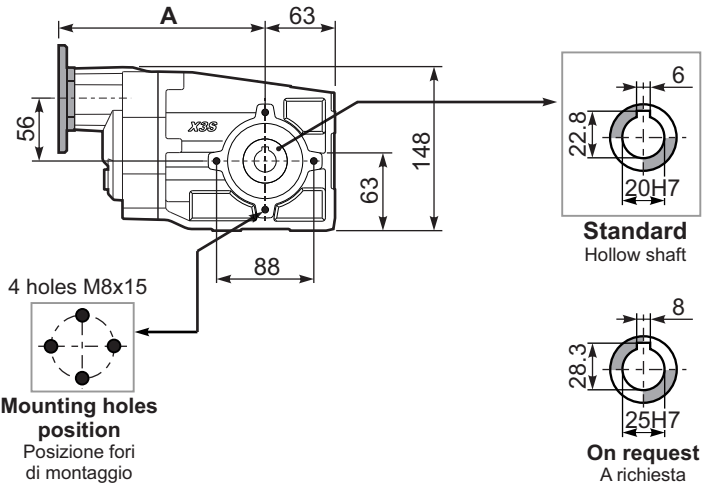
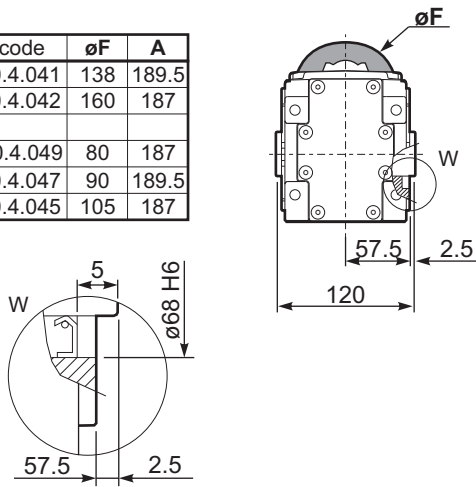

PX33S-N.. Feet
Piedi

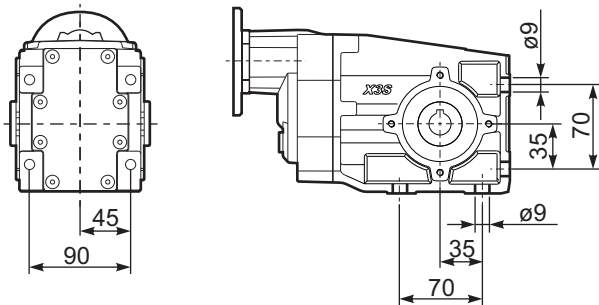

PX33S-F1.. Output flange
Flangia uscita

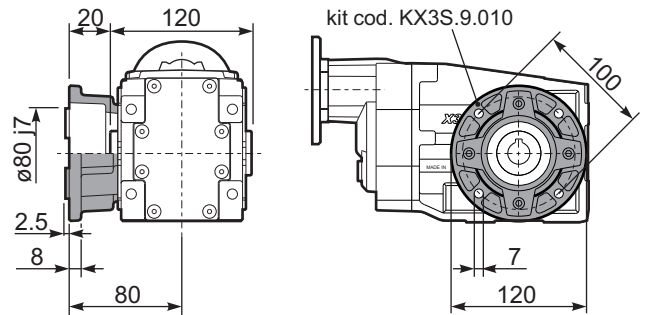

PX33S-F2.. Output flange
Flangia uscita

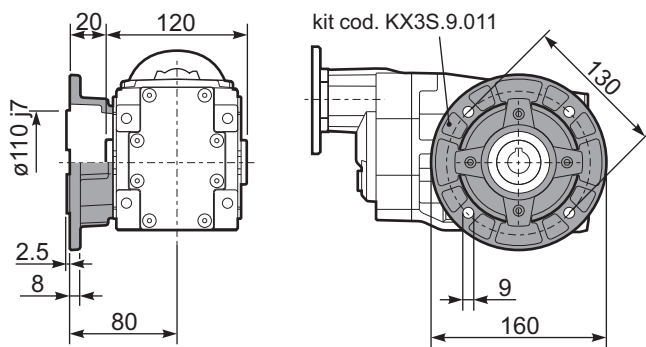

PX33SBR.. Reaction Arm
Braccio di reazione

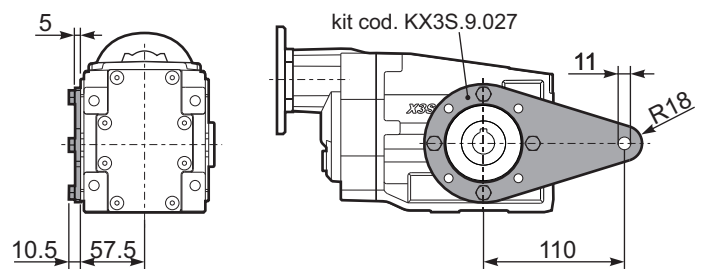

RX33S... Input shaft
Albero in entrata

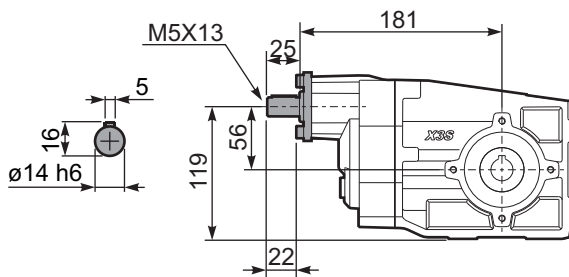

PX33S..A.. Single output shaft
Albero semplice in uscita

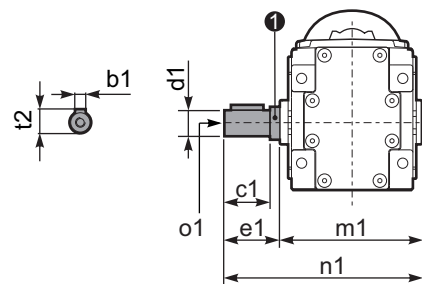

d1	b1	c1	e1	m1	n1	t2	o1	① kit code
ø20 ^{-0.005/-0.020}	6	37.5	40	120	140	22.5	M8x20	KX2S.5.028
ø25 ^{-0.005/-0.020}	8	60	63.2	126.8	190	28	M8x20	K063.5.028

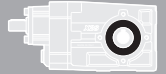

QUICK SELECTION / Selezione veloce The dynamic efficiency is **0.96** for all ratios **input speed (n₁) = 1400 min⁻¹**

Output Speed n ₂ [min ⁻¹]	Ratio i	Motor power P _{1M} [kW]	Output torque M _{2M} [Nm]	Service factor f.s.	Nominal power P _{1R} [kW]	Nominal torque M _{2R} [Nm]	Available B5 motor flanges					Available B14 motor flanges				Output Shaft 	Ratios code	
							B	C	D	E	F	Q	R	T	U			
							63	71	80	90	100 112	71	80	90	100 112			
192	7.29	2.2	104	0.9	2.0	95	B					C	C			2811		01
125	11.20	2.2	159	0.9	2.0	150	B					C	C			288		02
106	13.18	1.5	129	1.2	1.7	150	B					C	C			1911		03
92	15.27	1.1	109	1.4	1.5	150	B					C	C			1711		04
78	17.93	1.1	128	1.2	1.3	150	B					C	C			1511		05
69	20.25	1.1	145	1.0	1.1	150	B					C	C			198	standard	06
65	21.40	1.1	153	1.0	1.1	150	B					C	C			1311	ø25	07
60	23.47	0.75	115	1.3	0.98	150	B					C	C			178		08
51	27.55	0.75	135	1.1	0.83	150	B					C	C			158		09
47.9	29.21	0.75	143	1.0	0.78	150	B					C	C			1011	ø30	10
42.6	32.88	0.75	161	0.9	0.70	150	B					C	C			138	On request	11
36.7	38.12	0.55	138	1.1	0.60	150	B					C	C			911		12
31.2	44.89	0.55	163	0.9	0.51	150	B					C	C			108		13
27.8	50.34	0.37	122	1.1	0.40	131	B					C	C			711		14
23.9	58.58	0.37	142	1.1	0.39	150	B					C	C			98		15
18.1	77.36	0.25	126	1.2	0.30	150	B					C	C			78		16

Motor Flanges Available Flange Motore Disponibili B) Supplied with Reduction Bushing Fornito con Bussola di Riduzione B) Available on Request without reduction bushing Disponibile a Richiesta senza Bussola di Riduzione C) Motor Flange Holes Position Posizione Fori Flangia Motore

EN Unit **X42A** is supplied with synthetic oil for lifetime lubrication, no maintenance is necessary. See table 1 for lubrication and recommended quantity. In table 2 please see possible radial loads and axial loads on the gearbox.

I Il riduttore **X42A** viene fornito completo di olio sintetico per la lubrificazione permanente e non necessita di alcuna manutenzione. Vedi tab.1 per oli e quantità consigliati. In tab.2 sono presenti i carichi radiali e assiali applicabili al riduttore.

D Das Getriebe **X42A** ist mit synthetischem Öl gefüllt und ist lebensdauergeschmiert. In Tabelle 1 ist die Schmiermenge und das empfohlene Schmiermittel angegeben. In Tabelle 2 sind die zulässigen Radial- und Axialbelastungen des Getriebes aufgeführt.

F Le réducteur **X42A** est fourni complet avec de l'huile synthétique pour la lubrification permanente et ne nécessite aucun entretien. Voir tableau 1 concernant les huiles et les quantités conseillées. Les charges radiales et axiales applicables au réducteur sont précisées dans le tableau 2.

E El reductor tamaño **X42A** se suministra, lubricado de por vida con aceite sintético y no requieren mantenimiento alguna. Ver tabla 1, para cantidades y aceites recomendados. En la tabla 2, se encuentran las cargas radiales y axiales admitidas por el reductor.

Standard supplied	For these mounting position specify in the order or add oil Per queste posizioni specificare in fase d'ordine o aggiungere olio					
0.60 LT	0.75 LT	0.50 LT	0.70 LT	1.10 LT	0.60 LT	0.50 LT
AGIP Telium VSF 320			SHELL Omala S4 WE 320			

For all details on lubrication and plugs check our website [tab. 1](#)
Per maggiori dettagli su lubrificazione e tappi olio vedi il nostro sito web

RADIAL AND AXIAL LOADS

Output shaft

Albero di uscita

$$F_{eq} = F_R \cdot \frac{54}{X+28}$$

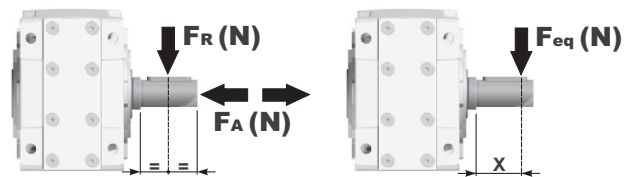

n ₂ [min ⁻¹]	FA	FR	n ₂ [min ⁻¹]	FA	FR	n ₂ [min ⁻¹]	FA	FR
250	500	2500	75	800	4000	15	960	4800
150	600	3000	50	960	4800			
100	700	3500	25	960	4800			

FR On request taper roller bearings to increase radial loads.
A richiesta cuscinetti a rulli conici per aumentare i carichi radiali.

Input shaft

albero in entrata

n ₁ [min ⁻¹]	FA	FR
1400	240	1200
900	280	1400
600	340	1700

***Strong axial loads in the DX direction are not allowed.**
Non sono consentiti forti carichi assiali con direzione DX

tab. 2

PX42AC... Basic Gearbox
Riduttore base

Gearbox weight
peso riduttore **7.82 kg**

M. flanges	Kit code	øF	A
63B5	K063.4.041	140	199.5
71B5	K063.4.042	160	197.5
80/90B5	K063.4.043	200	199.5
100/112B5	KC40.4.043	250	214.3
71B14	K063.4.047	105	197.5
80B14	K063.4.046	120	199.5
90B14	K063.4.041	140	199.5
100/112B14	KC40.4.041	160	214.3

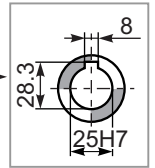
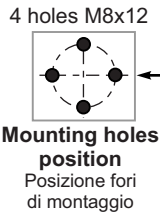
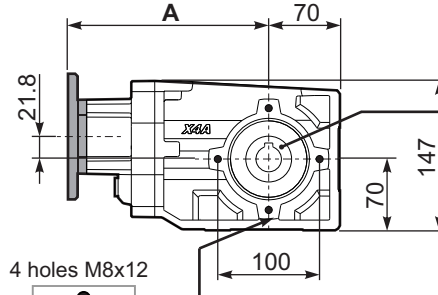
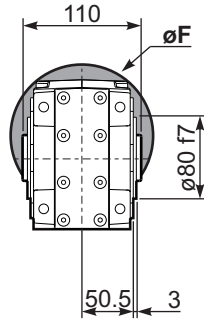

Standard
Hollow shaft

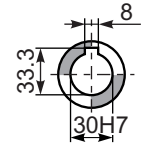

On request
A richiesta

PX42A-N.. Feet
Piedini

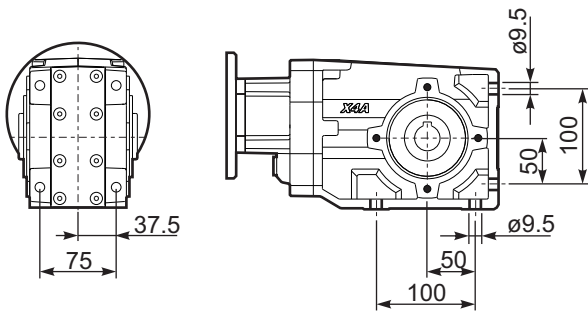

PX42A-F2.. Output flange
Flangia uscita

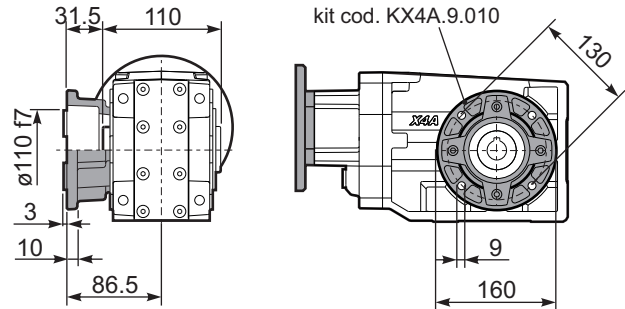

PX42A-F3.. Output flange
Flangia uscita

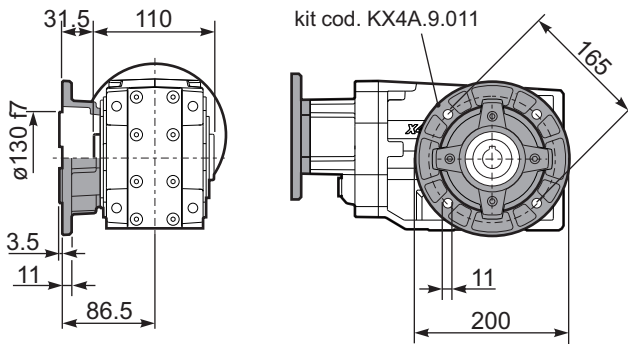

PX42A-F4.. Output flange
Flangia uscita

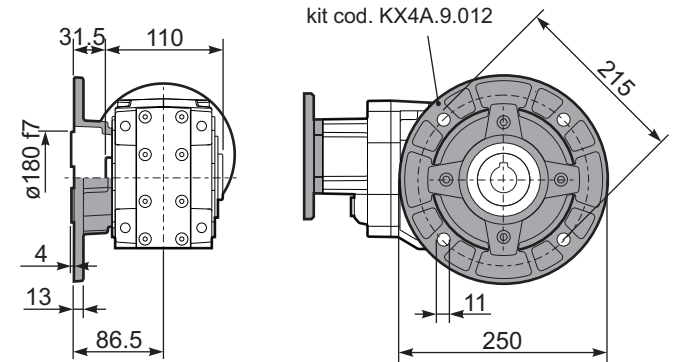

RX42A... Input shaft
Albero in entrata

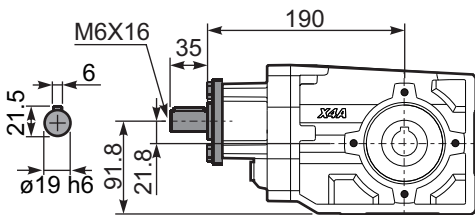

PX42ABR.. Reaction Arm
Braccio di reazione

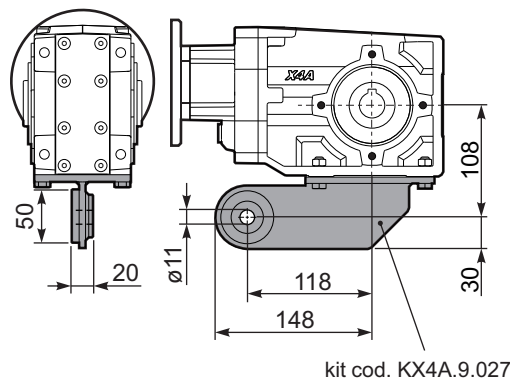

PX42A..A.. Single output shaft
Albero semplice in uscita

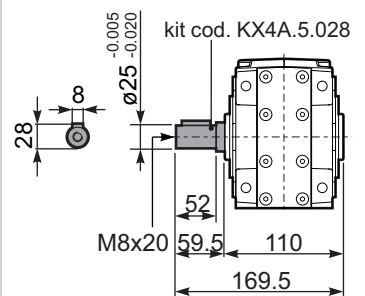

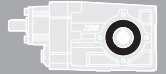

QUICK SELECTION / Selezione veloce The dynamic efficiency is **0.94** for all ratios **input speed (n₁) = 1400 min⁻¹**

Output Speed n ₂ [min ⁻¹]	Ratio i	Motor power P _{1M} [kW]	Output torque M _{2M} [Nm]	Service factor f.s.	Nominal power P _{1R} [kW]	Nominal torque M _{2R} [Nm]	Available B5 motor flanges		Available B14 motor flanges			Output Shaft 	Ratios code
							B	C	O	P	Q		
							63	71	56	63	71		
27.8	50.35	0.37	119	1.3	0.46	150			C	C		171311	01
25.4	55.22	0.37	131	1.1	0.42	150			C	C		17178	02
23.4	59.92	0.37	142	1.1	0.39	150			C	C		151311	03
21.3	65.72	0.37	156	1.0	0.36	150			C	C		15178	04
19.5	71.78	0.25	115	1.3	0.33	150			C	C		101711	05
17.6	79.44	0.25	127	1.2	0.29	150			C	C		13178	06
15.2	92.08	0.25	147	1.0	0.25	150			C	C		15138	07
14.7	95.03	0.25	152	1.0	0.25	150			C	C		91711	08
11.1	126.55	0.18	155	1.0	0.20	160			C	C		71711	09
10.5	133.15	0.18	163	1.0	0.19	160			C	C		91311	10
9.3	150.18	0.12	119	1.3	0.17	160			C	C		61711	11
7.9	177.30	0.12	140	1.1	0.14	160			C	C		71311	12
6.7	210.42	0.09	133	1.2	0.12	160			C	C		61311	13
6.1	230.79	0.09	146	1.1	0.11	160			C	C		6178	14
5.1	272.47	0.06	113	1.4	0.09	160			C	C		7138	15
4.3	323.37	0.06	134	1.2	0.08	160			C	C		6138	16

Motor Flanges Available Flange Motore Disponibili
 B) Supplied with Reduction Bushing Fornito con Bussola di Riduzione
 B) Available on Request without reduction bushing Disponibile a Richiesta senza Bussola di Riduzione
 C) Motor Flange Holes Position Posizione Fori Flangia Motore

EN Unit **X43A** is supplied with synthetic oil for lifetime lubrication, no maintenance is necessary. See table 1 for lubrication and recommended quantity. In table 2 please see possible radial loads and axial loads on the gearbox.

I Il riduttore **X43A** viene fornito completo di olio sintetico per la lubrificazione permanente e non necessita di alcuna manutenzione. Vedi tab.1 per oli e quantità consigliati. In tab.2 sono presenti i carichi radiali e assiali applicabili al riduttore.

D Das Getriebe **X43A** ist mit synthetischem Öl gefüllt und ist lebensdauergeschmiert. In Tabelle 1 ist die Schmiermenge und das empfohlene Schmiermittel angegeben. In Tabelle 2 sind die zulässigen Radial- und Axialbelastungen des Getriebes aufgeführt.

F Le réducteur **X43A** est fourni complet avec de l'huile synthétique pour la lubrification permanente et ne nécessite aucun entretien. Voir tableau 1 concernant les huiles et les quantités conseillées. Les charges radiales et axiales applicables au réducteur sont précisées dans le tableau 2.

E El reductor tamaño **X43A** se suministra, lubricado de por vida con aceite sintético y no requieren mantenimiento alguna. Ver tabla 1, para cantidades y aceites recomendados. En la tabla 2, se encuentran las cargas radiales y axiales admitidas por el reductor.

Standard supplied	For these mounting position specify in the order or add oil Per queste posizioni specificare in fase d'ordine o aggiungere olio					
B3	B6	B7	B8	V5	V6	V8
0.80 LT	0.80 LT	0.60 LT	0.80 LT	1.20 LT	0.70 LT	0.70 LT
AGIP Telium VSF 320			SHELL Omala S4 WE 320			

For all details on lubrication and plugs check our website **tab. 1**
Per maggiori dettagli su lubrificazione e tappi olio vedi il nostro sito web

RADIAL AND AXIAL LOADS

Output shaft

Albero di uscita

$$F_{eq} = F_R \cdot \frac{54}{X+28}$$

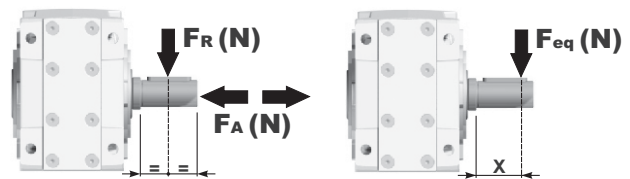

n ₂ [min ⁻¹]	FA	FR	n ₂ [min ⁻¹]	FA	FR	n ₂ [min ⁻¹]	FA	FR
250	500	2500	75	800	4000	15	960	4800
150	600	3000	50	960	4800			
100	700	3500	25	960	4800			

FR On request taper roller bearings to increase radial loads.
A richiesta cuscinetti a rulli conici per aumentare i carichi radiali.

Input shaft

albero in entrata

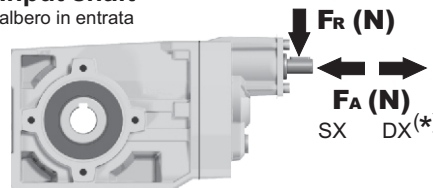

n ₁ [min ⁻¹]	FA [N]	FR [N]
1400	140	700
900	160	800
600	190	950

***Strong axial loads in the DX direction are not allowed.**
Non sono consentiti forti carichi assiali con direzione DX

PX43AC... Basic Gearbox
Riduttore base

Gearbox weight
peso riduttore **7.93 kg**

M. flanges	Kit code	øF	A
63B5	K050.4.041	138	205
71B5	K050.4.042	160	202.5
56B14	KC40.4.049	80	202.5
63B14	K050.4.047	90	205
71B14	K050.4.045	105	202.5

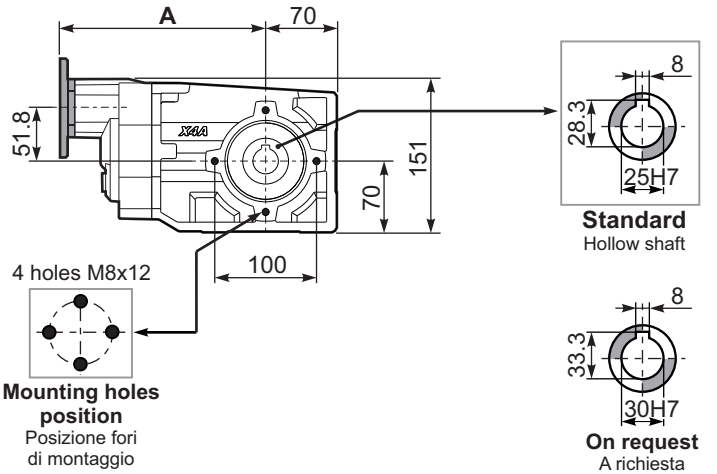
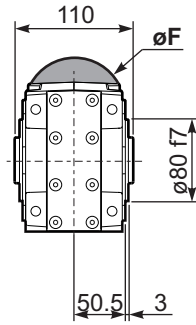

PX43A-N.. Feet
Piedini

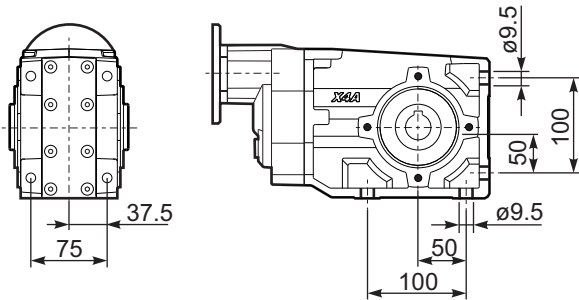

PX43A-F2.. Output flange
Flangia uscita

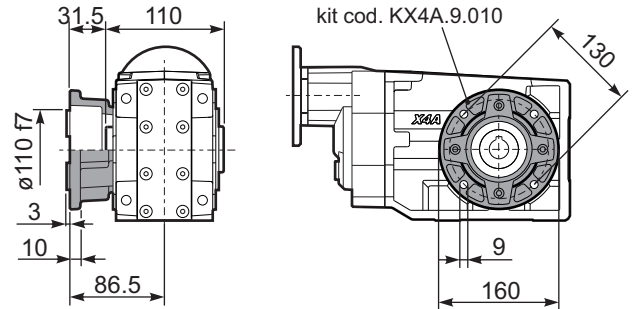

PX43A-F3.. Output flange
Flangia uscita

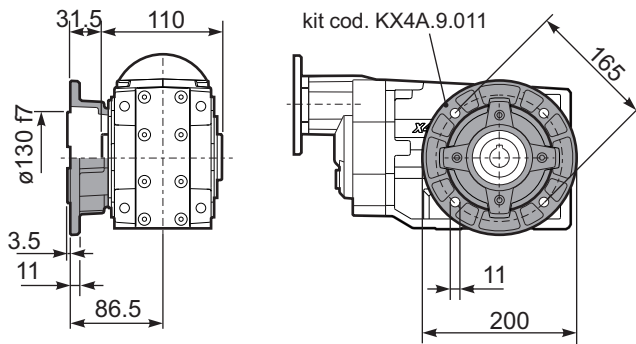

PX43A-F4.. Output flange
Flangia uscita

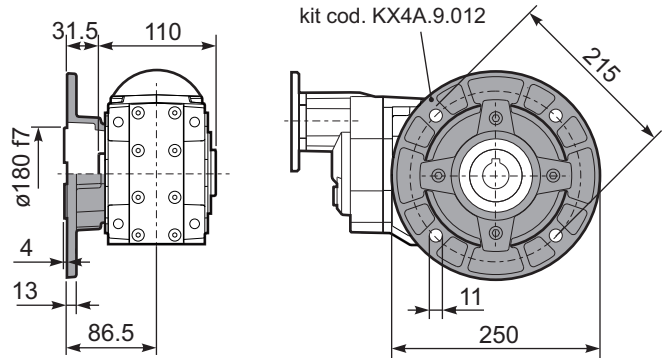

RX43A... Input shaft
Albero in entrata

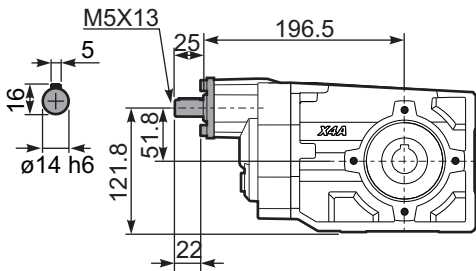

PX43ABR.. Reaction Arm
Braccio di reazione

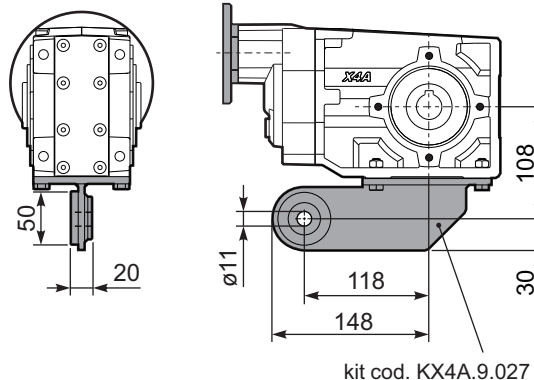

PX43A..A.. Single output shaft
Albero semplice in uscita

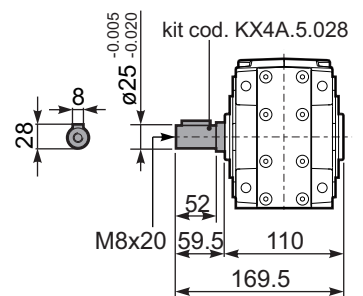



QUICK SELECTION / Selezione veloce The dynamic efficiency is **0.96** for all ratios **input speed (n₁) = 1400 min⁻¹**

Output Speed n ₂ [min ⁻¹]	Ratio i	Motor power P _{1M} [kW]	Output torque M _{2M} [Nm]	Service factor f.s.	Nominal power P _{1R} [kW]	Nominal torque M _{2R} [Nm]	Available B5 motor flanges				Available B14 motor flanges			Output Shaft 	Ratios code
							C	D	E	F	R	T	U		
							71	80	90	100 112	80	90	100 112		
232	6.03	3	116	1.2	3.4	135	B							3011	01
151	9.26	3	179	0.9	2.6	155	B							308	02
123	11.36	3	219	1.0	3.1	230	B							2011	03
91	15.36	2.2	218	1.1	2.5	250	B							1611	04
80	17.46	2.2	248	1.0	2.2	250	B							208	05
70	19.97	2.2	284	0.9	1.9	250	B							1311	06
59	23.60	1.5	231	1.1	1.6	250	B							168	07
57	24.45	1.5	239	1.0	1.6	250	B							1111	08
45.6	30.69	1.1	220	1.1	1.2	250	B							138	09
39.6	35.35	1.1	253	1.0	1.1	250	B							811	10
37.3	37.57	1.1	269	0.9	1.0	250	B							118	11
28.8	48.68	0.75	239	1.0	0.78	250	B							611	12
25.8	54.33	0.75	267	0.9	0.70	250	B							88	13
18.7	74.81	0.37	181	1.2	0.43	210	B							68	14

A) Motor Flanges Available
Flange Motore Disponibili

B) Supplied with Reduction Bushing
Fornito con Bussola di Riduzione

B) Available on Request without reduction bushing
Disponibile a Richiesta senza Bussola di Riduzione

C) Motor Flange Holes Position
Posizione Fori Flangia Motore

EN Unit **X52A** is supplied with synthetic oil for lifetime lubrication, no maintenance is necessary. See table 1 for lubrication and recommended quantity. In table 2 please see possible radial loads and axial loads on the gearbox.

I Il riduttore **X52A** viene fornito completo di olio sintetico per la lubrificazione permanente e non necessita di alcuna manutenzione. Vedi tab.1 per oli e quantità consigliati. In tab.2 sono presenti i carichi radiali e assiali applicabili al riduttore.

D Das Getriebe **X52A** ist mit synthetischem Öl gefüllt und ist lebensdauergeschmiert. In Tabelle 1 ist die Schmiermenge und das empfohlene Schmiermittel angegeben. In Tabelle 2 sind die zulässigen Radial - und Axialbelastungen des Getriebes aufgeführt.

F Le réducteur **X52A** est fourni complet avec de l'huile synthétique pour la lubrification permanente et ne nécessite aucun entretien. Voir tableau 1 concernant les huiles et les quantités conseillées. Les charges radiales et axiales applicables au réducteur sont précisées dans le tableau 2.

E El reductor tamaño **X52A** se suministra, lubricado de por vida con aceite sintético y no requieren mantenimiento alguna. Ver tabla 1, para cantidades y aceites recomendados. En la tabla 2, se encuentran las cargas radiales y axiales admitidas por el reductor.

Standard supplied	For these mounting position specify in the order or add oil Per queste posizioni specificare in fase d'ordine o aggiungere olio						
B3	B6	B7	B8	V5	V6	V8	
0.90 LT	1.50LT	0.75 LT	1.40 LT	1.95 LT	1.15 LT	0.80 LT	
AGIP Telium VSF 320				SHELL Omala S4 WE 320			

For all details on lubrication and plugs check our website **tab. 1**
Per maggiori dettagli su lubrificazione e tappi olio vedi il nostro sito web

RADIAL AND AXIAL LOADS

Output shaft
Albero di uscita

$$F_{eq} = F_R \cdot \frac{61.5}{X+31}$$

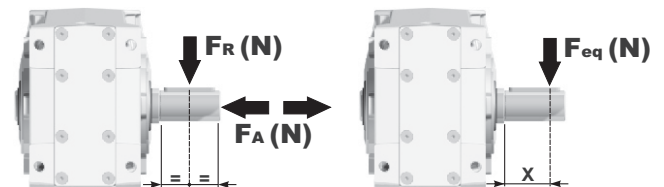

n ₂ [min ⁻¹]	FA	FR	n ₂ [min ⁻¹]	FA	FR	n ₂ [min ⁻¹]	FA	FR
250	600	3000	75	820	4100	15	1660	8300
150	700	3500	50	960	4800			
100	800	4000	25	1350	6750			

F_R On request taper roller bearings to increase radial loads.
A richiesta cuscinetti a rulli conici per aumentare i carichi radiali.

Input shaft
albero in entrata

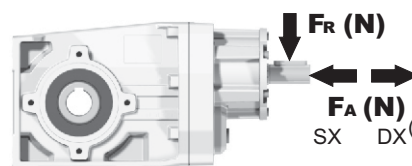

n ₁ [min ⁻¹]	FA	FR
1400	400	2000
900	440	2200
600	440	2200

***Strong axial loads in the DX direction are not allowed.**
Non sono consentiti forti carichi assiali con direzione DX

tab. 2

PX52AC... Basic Gearbox
Riduttore base

Gearbox weight **12.80 kg**
peso riduttore

M. flanges	Kit code	øF	A
71B5	KC023.4.041	160	234
80/90B5	KC023.4.042	200	236
100/112B5	KC023.4.043	250	245
80B14	KC085.4.046	120	236
90B14	KC085.4.045	140	236
100/112B14	KC085.4.047	160	245

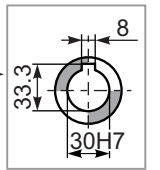
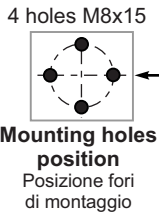
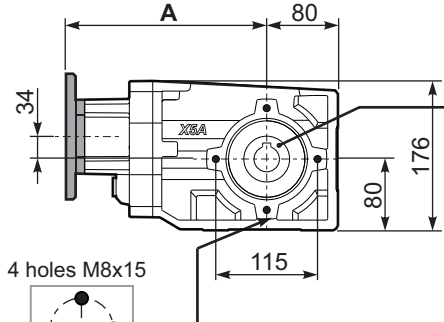
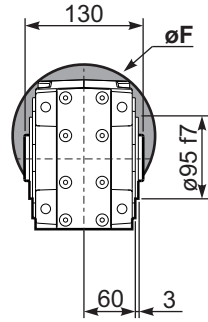

Standard
Hollow shaft

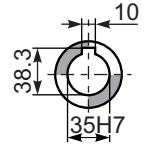

On request
A richiesta

PX52A-N.. Feet
Piedini

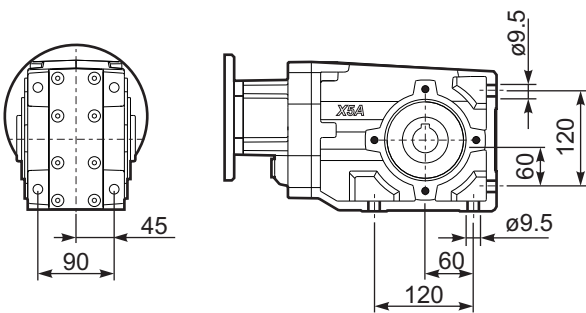

PX52A-F2.. Output flange
Flangia uscita

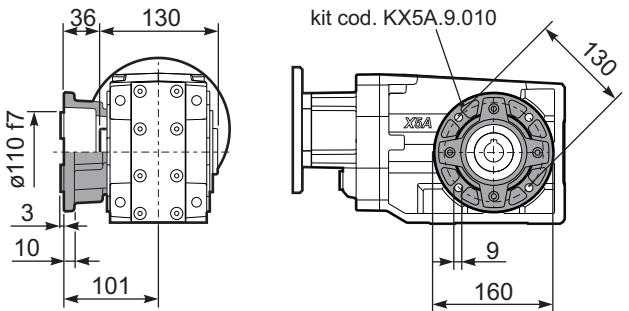

PX52A-F3.. Output flange
Flangia uscita

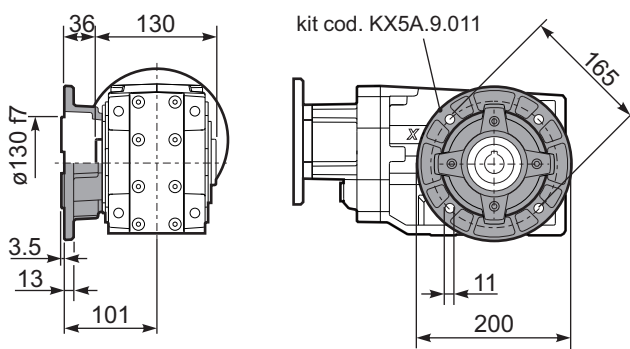

PX52A-F4.. Output flange
Flangia uscita

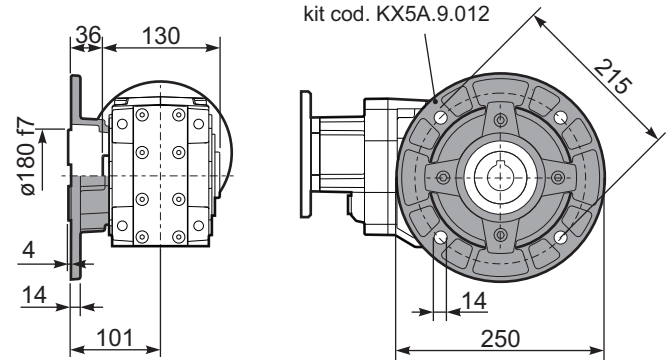

RX52A... Input shaft
Albero in entrata

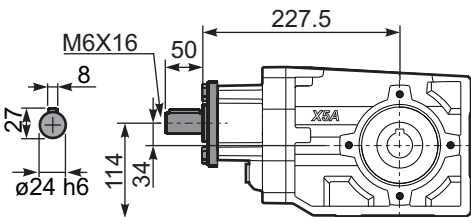

PX52ABR.. Reaction Arm
Braccio di reazione

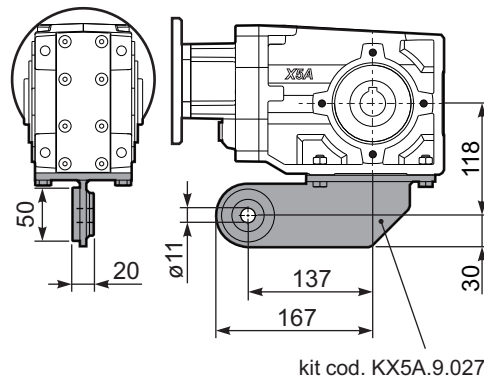

PX52A..A.. Single output shaft
Albero semplice in uscita

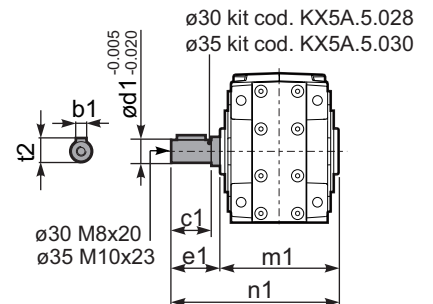

	b1	c1	d1	e1	m1	n1	t2
ø30	8	60	30	68	134	202	33
ø35	10	60	35	73.5	141	214.5	38

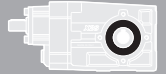

QUICK SELECTION / Selezione veloce The dynamic efficiency is **0.94** for all ratios **input speed (n₁) = 1400 min⁻¹**

Output Speed n ₂ [min ⁻¹]	Ratio i	Motor power P _{1M} [kW]	Output torque M _{2M} [Nm]	Service factor f.s.	Nominal power P _{1R} [kW]	Nominal torque M _{2R} [Nm]	Available B5 motor flanges				Available B14 motor flanges			Output Shaft 	Ratios code
							B	C	D	E	Q	R	T		
							63	71	80	90	71	80	90		
24.7	56.76	0.55	201	1.2	0.69	250	B				C	C		191311	01
21.3	65.79	0.55	233	1.1	0.59	250	B				C	C		171311	02
18.1	77.23	0.55	274	0.9	0.50	250	B				C	C		151311	03
16.0	87.23	0.37	207	1.2	0.45	250	B				C	C		19138	04
15.2	92.18	0.37	219	1.1	0.42	250	B				C	C		131311	05
13.9	100.47	0.37	238	1.0	0.39	250	B				C	C		19811	06
12.0	116.45	0.37	276	0.9	0.33	250	B				C	C		17811	07
11.1	125.82	0.25	201	1.2	0.31	250	B				C	C		101311	08
9.9	141.66	0.25	227	1.1	0.28	250	B				C	C		13138	09
8.6	163.16	0.25	261	1.0	0.24	250	B				C	C		13811	10
7.8	178.96	0.18	219	1.1	0.22	250	B				C	C		1788	11
7.2	193.36	0.18	237	1.1	0.20	250	B				C	C		10138	12
6.5	216.84	0.18	265	0.9	0.18	250	B				C	C		71311	13
5.5	252.36	0.12	200	1.3	0.15	250	B				C	C		9138	14
4.8	290.67	0.12	230	1.1	0.13	250	B				C	C		9811	15
4.2	333.23	0.09	210	1.2	0.12	250	B				C	C		7138	16
3.6	383.82	0.09	242	1.0	0.10	250	B				C	C		7811	17
3.1	446.70	0.09	282	0.9	0.09	250	B				C	C		988	18
2.4	589.85	0.06	244	1.0	0.07	250	B				C	C		788	19

Motor Flanges Available
Flange Motore Disponibili

B) Supplied with Reduction Bushing
Fornito con Bussola di Riduzione

B) Available on Request without reduction bushing
Disponibile a Richiesta senza Bussola di Riduzione

C) Motor Flange Holes Position
Posizione Fori Flangia Motore

EN Unit **X53A** is supplied with synthetic oil for lifetime lubrication, no maintenance is necessary. See table 1 for lubrication and recommended quantity. In table 2 please see possible radial loads and axial loads on the gearbox.

I Il riduttore **X53A** viene fornito completo di olio sintetico per la lubrificazione permanente e non necessita di alcuna manutenzione. Vedi tab.1 per oli e quantità consigliati. In tab.2 sono presenti i carichi radiali e assiali applicabili al riduttore.

D Das Getriebe **X53A** ist mit synthetischem Öl gefüllt und ist lebensdauergeschmiert. In Tabelle 1 ist die Schmiermenge und das empfohlene Schmiermittel angegeben. In Tabelle 2 sind die zulässigen Radial- und Axialbelastungen des Getriebes aufgeführt.

F Le réducteur **X53A** est fourni complet avec de l'huile synthétique pour la lubrification permanente et ne nécessite aucun entretien. Voir tableau 1 concernant les huiles et les quantités conseillées. Les charges radiales et axiales applicables au réducteur sont précisées dans le tableau 2.

E El reductor tamaño **X53A** se suministra, lubricado de por vida con aceite sintético y no requieren mantenimiento alguna. Ver tabla 1, para cantidades y aceites recomendados. En la tabla 2, se encuentran las cargas radiales y axiales admitidas por el reductor.

Standard supplied	For these mounting position specify in the order or add oil Per queste posizioni specificare in fase d'ordine o aggiungere olio						
1.30 LT	1.55 LT	0.85 LT	1.45 LT	2.10 LT	1.25 LT	0.95 LT	
AGIP Telium VSF 320				SHELL Omala S4 WE 320			

For all details on lubrication and plugs check our website **tab. 1**
Per maggiori dettagli su lubrificazione e tappi olio vedi il nostro sito web

RADIAL AND AXIAL LOADS

Output shaft
Albero di uscita

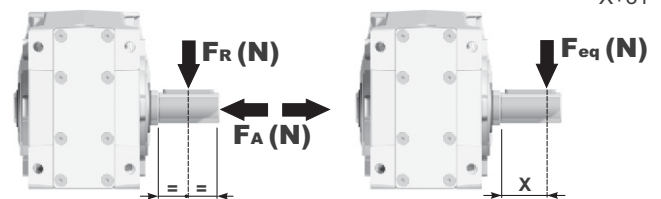

n ₂ [min ⁻¹]	FA	FR	n ₂ [min ⁻¹]	FA	FR	n ₂ [min ⁻¹]	FA	FR
250	600	3000	75	820	4100	15	1660	8300
150	700	3500	50	960	4800			
100	800	4000	25	1350	6750			

FR On request taper roller bearings to increase radial loads.
A richiesta cuscinetti a rulli conici per aumentare i carichi radiali.

Input shaft
albero in entrata

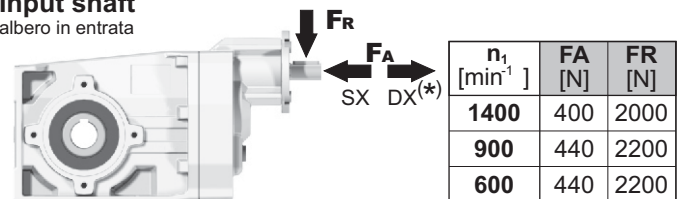

n ₁ [min ⁻¹]	FA [N]	FR [N]
1400	400	2000
900	440	2200
600	440	2200

*Strong axial loads in the DX direction are not allowed.
Non sono consentiti forti carichi assiali con direzione DX

tab. 2

PX53AC... Basic Gearbox
Riduttore base

Gearbox weight
peso riduttore **12.65 kg**

M. flanges	Kit code	øF	A
63B5	K063.4.041	140	246
71B5	K063.4.042	160	244
80/90B5	K063.4.043	200	246
71B14	K063.4.047	105	244
80B14	K063.4.046	120	246
90B14	K063.4.041	140	246

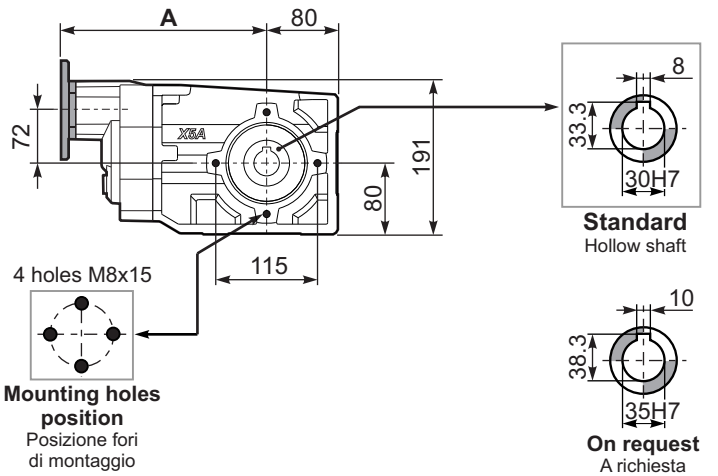
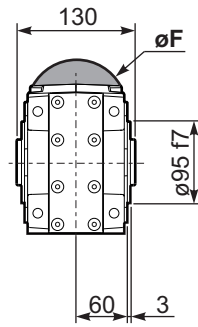

PX53A-N.. Feet
Piedini

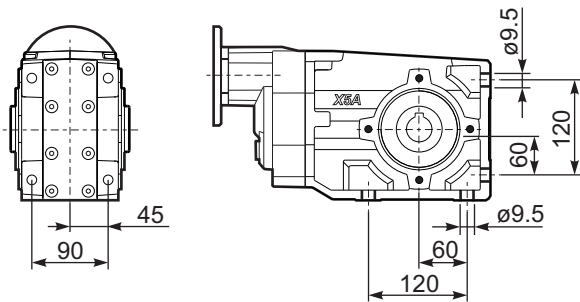

PX53A-F2.. Output flange
Flangia uscita

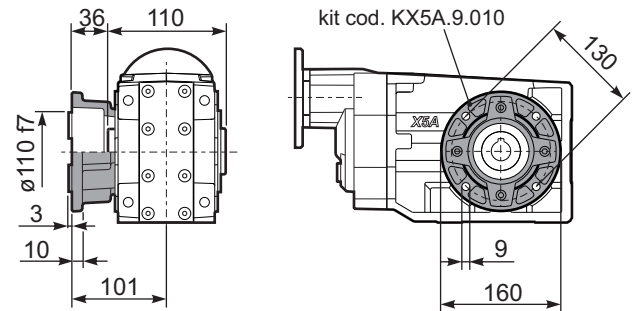

PX53A-F3.. Output flange
Flangia uscita

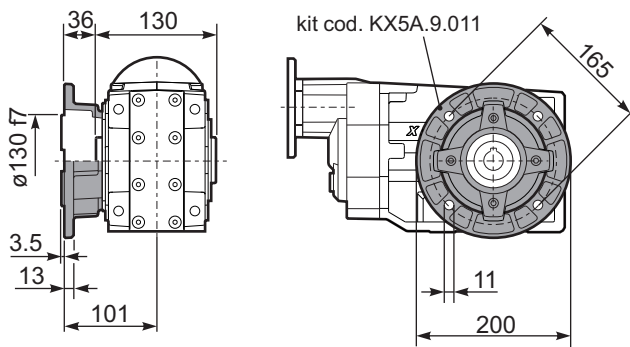

PX53A-F4.. Output flange
Flangia uscita

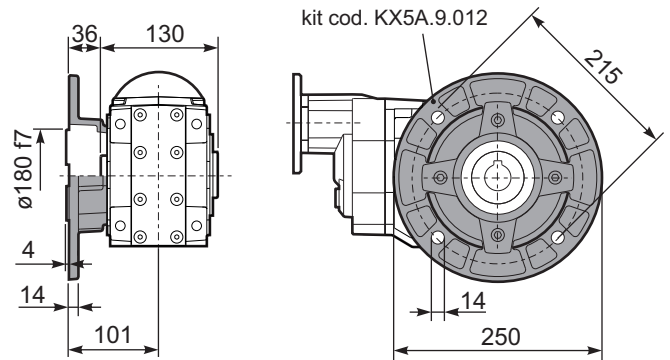

RX53A... Input shaft
Albero in entrata

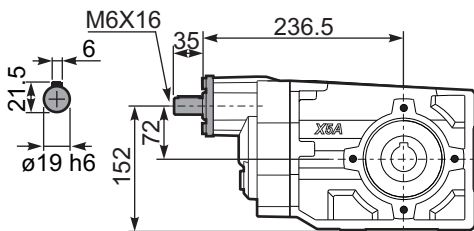

PX53ABR.. Reaction Arm
Braccio di reazione

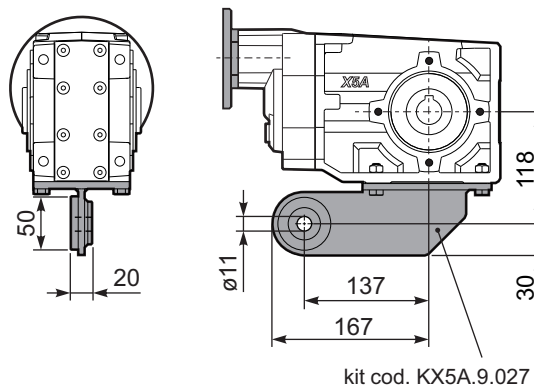

PX53A..A.. Single output shaft
Albero semplice in uscita

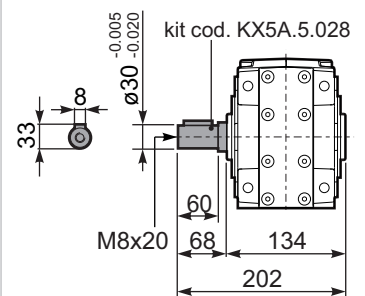

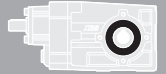

QUICK SELECTION / Selezione veloce The dynamic efficiency is **0.96** for all ratios **input speed (n₁) = 1400 min⁻¹**

Output Speed n ₂ [min ⁻¹]	Ratio i	Motor power P _{1M} [kW]	Output torque M _{2M} [Nm]	Service factor f.s.	Nominal power P _{1R} [kW]	Nominal torque M _{2R} [Nm]	Available B5 motor flanges					Available B14 motor flanges				Output Shaft 	Ratios code	
							C	D	E	F	G	R	T	U	V			
							71	80	90	100 112	132	80	90	100 112	132			
232	6.03	5.5	211	1.1	6.1	240	B										3011	01
151	9.26	4	238	1.1	4.5	270	B										308	02
123	11.36	4	291	1.2	4.7	350	B										2011	03
91	15.36	4	394	1.0	3.8	385	B										1611	04
80	17.46	4	448	0.9	3.5	400	B										208	05
70	19.97	3	386	1.1	3.1	410	B										1311	06
59	23.60	3	456	0.9	2.7	410	B										168	07
57	24.45	3	472	0.9	2.6	410	B										1111	08
45.6	30.69	2.2	436	0.9	2.0	410	B										138	09
39.6	35.35	1.5	346	1.2	1.8	410	B										811	10
37.3	37.57	1.5	368	1.1	1.7	410	B										118	11
28.8	48.68	1.1	348	1.0	1.1	365	B										611	12
25.8	54.33	1.1	389	1.1	1.2	410	B										88	13
18.7	74.81	0.75	367	1.0	0.73	360	B										68	14

Motor Flanges Available Flange Motore Disponibili
B) Supplied with Reduction Bushing Fornito con Bussola di Riduzione
B) Available on Request without reduction bushing Disponibile a Richiesta senza Bussola di Riduzione
C) Motor Flange Holes Position Posizione Fori Flangia Motore

EN Unit **X62A** is supplied with synthetic oil for lifetime lubrication, no maintenance is necessary. See table 1 for lubrication and recommended quantity. In table 2 please see possible radial loads and axial loads on the gearbox.

I Il riduttore **X62A** viene fornito completo di olio sintetico per la lubrificazione permanente e non necessita di alcuna manutenzione. Vedi tab.1 per oli e quantità consigliati. In tab.2 sono presenti i carichi radiali e assiali applicabili al riduttore.

D Das Getriebe **X62A** ist mit synthetischem Öl gefüllt und ist lebensdauergeschmiert. In Tabelle 1 ist die Schmiermenge und das empfohlene Schmiermittel angegeben. In Tabelle 2 sind die zulässigen Radial - und Axialbelastungen des Getriebes aufgeführt.

F Le réducteur **X62A** est fourni complet avec de l'huile synthétique pour la lubrification permanente et ne nécessite aucun entretien. Voir tableau 1 concernant les huiles et les quantités conseillées. Les charges radiales et axiales applicables au réducteur sont précisées dans le tableau 2.

E El reductor tamaño **X62A** se suministra, lubricado de por vida con aceite sintético y no requieren mantenimiento alguna. Ver tabla 1, para cantidades y aceites recomendados. En la tabla 2, se encuentran las cargas radiales y axiales admitidas por el reductor.

Standard supplied	For these mounting position specify in the order or add oil Per queste posizioni specificare in fase d'ordine o aggiungere olio						
B3	B6	B7	B8	V5	V6	V8	
1.25 LT	1.70 LT	0.95 LT	1.60 LT	2.45 LT	1.50 LT	1.10 LT	
AGIP Telium VSF 320				SHELL Omala S4 WE 320			

For all details on lubrication and plugs check our website **tab. 1**
Per maggiori dettagli su lubrificazione e tappi olio vedi il nostro sito web

RADIAL AND AXIAL LOADS

Output shaft
Albero di uscita

$$F_{eq} = F_R \cdot \frac{69}{X+39}$$

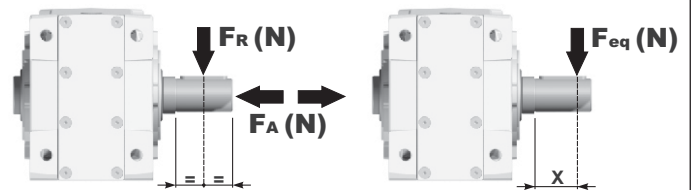

n ₂ [min ⁻¹]	FA	FR	n ₂ [min ⁻¹]	FA	FR	n ₂ [min ⁻¹]	FA	FR
250	600	3000	75	890	4450	15	1660	8300
150	700	3500	50	1140	5700			
100	780	3900	25	1330	6650			

FR On request taper roller bearings to increase radial loads.
A richiesta cuscinetti a rulli conici per aumentare i carichi radiali.

Input shaft
albero in entrata

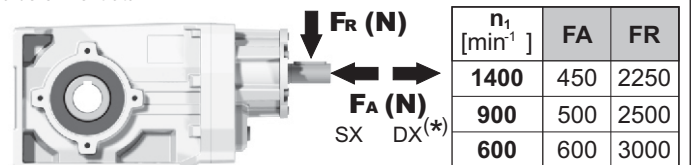

n ₁ [min ⁻¹]	FA	FR
1400	450	2250
900	500	2500
600	600	3000

***Strong axial loads in the DX direction are not allowed.**
Non sono consentiti forti carichi assiali con direzione DX

tab. 2

PX62AC... Basic Gearbox
Riduttore base

Gearbox weight **15.80 kg**
peso riduttore

M. flanges	Kit code	øF	A
71B5	KC023.4.041	160	253
80/90B5	KC023.4.042	200	255
100/112B5	KC023.4.043	250	264
132B5	KC50.4.043	300	282
80B14	KC085.4.046	120	255
90B14	KC085.4.045	140	255
100/112B14	KC085.4.047	160	264
132B14	KC50.4.041	200	282

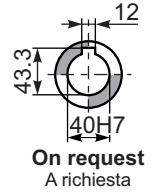
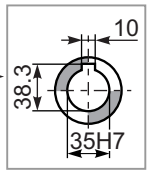
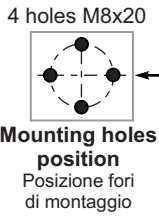
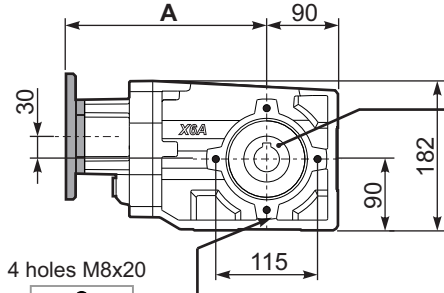
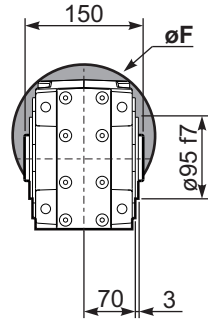

PX62A-N.. Feet
Piedini

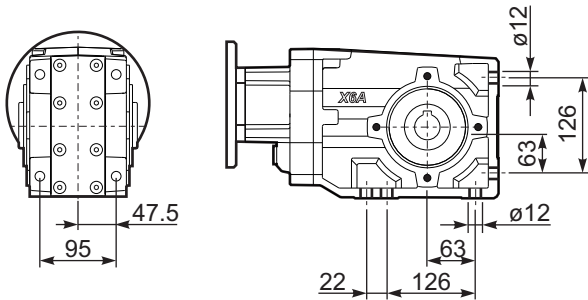

PX62A-F2.. Output flange
Flangia uscita

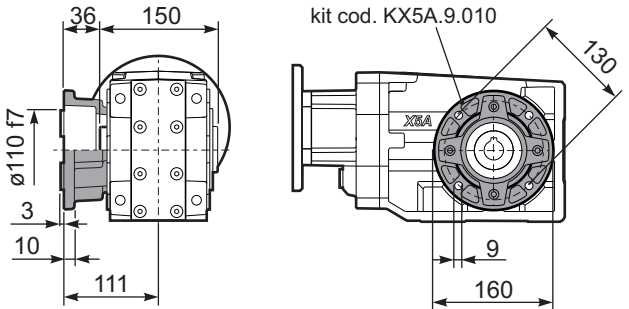

PX62A-F3.. Output flange
Flangia uscita

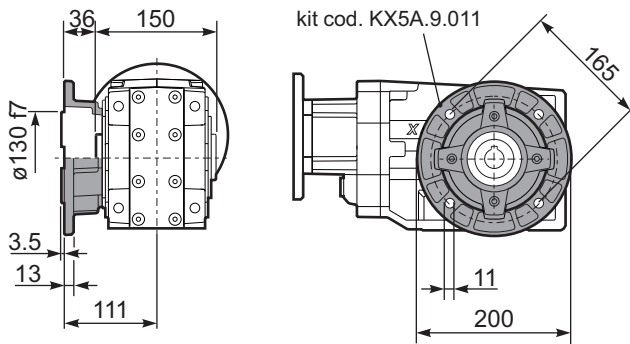

PX62A-F4.. Output flange
Flangia uscita

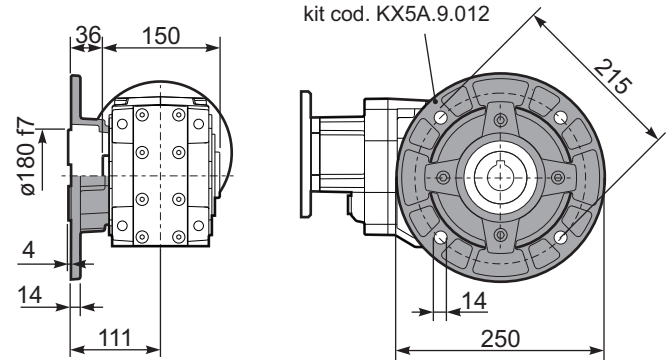

RX62A... Input shaft
Albero in entrata

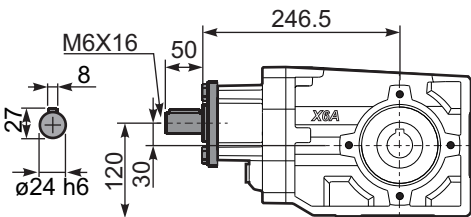

PX62ABR.. Reaction Arm
Braccio di reazione

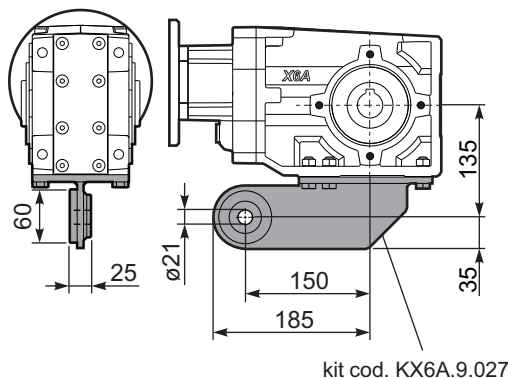

PX62A..A.. Single output shaft
Albero semplice in uscita

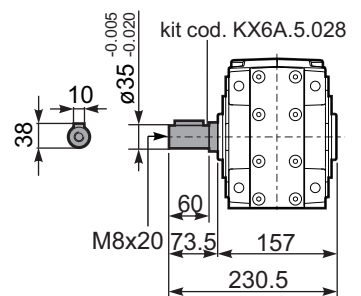

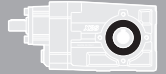

QUICK SELECTION / Selezione veloce The dynamic efficiency is **0.94** for all ratios **input speed (n₁) = 1400 min⁻¹**

Output Speed n ₂ [min ⁻¹]	Ratio i	Motor power P _{1M} [kW]	Output torque M _{2M} [Nm]	Service factor f.s.	Nominal power P _{1R} [kW]	Nominal torque M _{2R} [Nm]	Available B5 motor flanges				Available B14 motor flanges			Output Shaft 	Ratios code
							B	C	D	E	Q	R	T		
							63	71	80	90	71	80	90		
24.7	56.76	1.1	398	1.0	1.1	410	B				C	C		191311	01
21.3	65.79	0.75	316	1.3	0.97	410	B				C	C		171311	02
18.1	77.23	0.75	371	1.1	0.83	410	B				C	C		151311	03
16.0	87.23	0.75	420	1.0	0.73	410	B				C	C		19138	04
15.2	92.18	0.75	443	0.9	0.69	410	B				C	C		131311	05
13.9	100.47	0.55	357	1.2	0.64	410	B				C	C		19811	06
12.0	116.45	0.55	413	1.0	0.55	410	B				C	C		17811	07
11.1	125.82	0.55	446	0.9	0.51	410	B				C	C		101311	08
9.9	141.66	0.37	336	1.2	0.45	410	B				C	C		13138	09
8.6	163.16	0.37	387	1.1	0.39	410	B				C	C		13811	10
7.8	178.96	0.37	424	1.0	0.36	410	B				C	C		1788	11
7.2	193.36	0.37	459	0.9	0.33	410	B				C	C		10138	12
6.5	216.84	0.25	347	1.2	0.29	410	B				C	C		71311	13
5.5	252.36	0.25	404	1.0	0.25	410	B				C	C		9138	14
4.8	290.67	0.25	465	0.9	0.22	410	B				C	C		9811	15
4.2	333.23	0.18	408	1.0	0.19	410	B				C	C		7138	16
3.6	383.82	0.18	470	0.9	0.17	410	B				C	C		7811	17
3.1	446.70	0.12	353	1.2	0.14	410	B				C	C		988	18
2.4	589.85	0.09	372	1.1	0.11	410	B				C	C		788	19

Motor Flanges Available Flange Motore Disponibili
 B) Supplied with Reduction Bushing Fornito con Bussola di Riduzione
 B) Available on Request without reduction bushing Disponibile a Richiesta senza Bussola di Riduzione
 C) Motor Flange Holes Position Posizione Fori Flangia Motore

EN Unit **X63A** is supplied with synthetic oil for lifetime lubrication, no maintenance is necessary. See table 1 for lubrication and recommended quantity. In table 2 please see possible radial loads and axial loads on the gearbox.

I Il riduttore **X63A** viene fornito completo di olio sintetico per la lubrificazione permanente e non necessita di alcuna manutenzione. Vedi tab.1 per oli e quantità consigliati. In tab.2 sono presenti i carichi radiali e assiali applicabili al riduttore.

D Das Getriebe **X63A** ist mit synthetischem Öl gefüllt und ist lebensdauer geschmiert. In Tabelle 1 ist die Schmiermenge und das empfohlene Schmiermittel angegeben. In Tabelle 2 sind die zulässigen Radial - und Axialbelastungen des Getriebes aufgeführt.

F Le réducteur **X63A** est fourni complet avec de l'huile synthétique pour la lubrification permanente et ne nécessite aucun entretien. Voir tableau 1 concernant les huiles et les quantités conseillées. Les charges radiales et axiales applicables au réducteur sont précisées dans le tableau 2.

E El reductor tamaño **X63A** se suministra, lubricado de por vida con aceite sintético y no requieren mantenimiento alguna. Ver tabla 1, para cantidades y aceites recomendados. En la tabla 2, se encuentran las cargas radiales y axiales admitidas por el reductor.

Standard supplied	For these mounting position specify in the order or add oil Per queste posizioni specificare in fase d'ordine o aggiungere olio						
1.80 LT	1.80 LT	1.05 LT	1.70 LT	2.60 LT	1.65 LT	1.30 LT	
AGIP Telium VSF 320				SHELL Omala S4 WE 320			

For all details on lubrication and plugs check our website **tab. 1**
Per maggiori dettagli su lubrificazione e tappi olio vedi il nostro sito web

RADIAL AND AXIAL LOADS

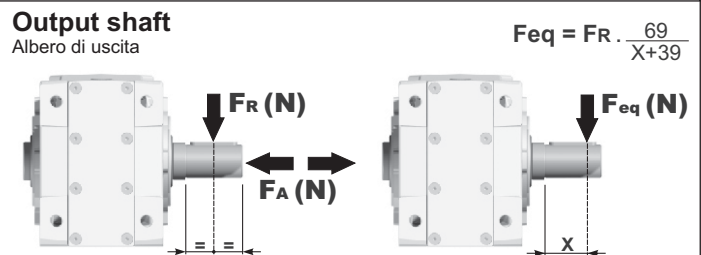

n ₂ [min ⁻¹]	FA	FR	n ₂ [min ⁻¹]	FA	FR	n ₂ [min ⁻¹]	FA	FR
250	600	3000	75	890	4450	15	1660	8300
150	700	3500	50	1140	5700			
100	780	3900	25	1330	6650			

F_R On request taper roller bearings to increase radial loads.
A richiesta cuscinetti a rulli conici per aumentare i carichi radiali.

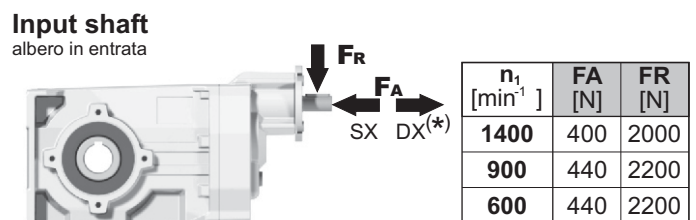

*Strong axial loads in the DX direction are not allowed.
Non sono consentiti forti carichi assiali con direzione DX

tab. 2

PX63AC... Basic Gearbox
Riduttore base

Gearbox weight **15.98 kg**
peso riduttore

M. flanges	Kit code	øF	A
63B5	K063.4.041	140	265
71B5	K063.4.042	160	263
80/90B5	K063.4.043	200	265
71B14	K063.4.047	105	263
80B14	K063.4.046	120	265
90B14	K063.4.041	140	265

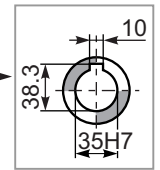
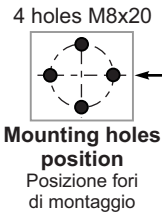
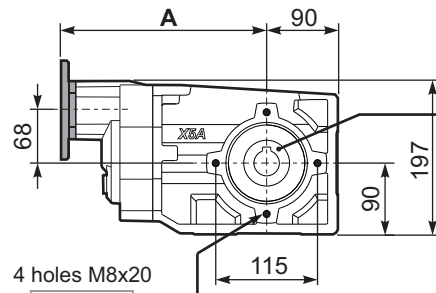
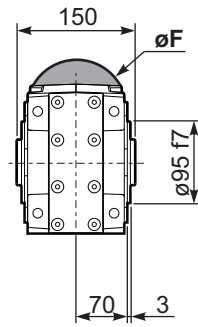

Standard
Hollow shaft

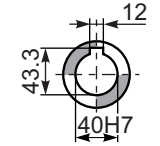

On request
A richiesta

PX63A-N.. Feet
Piedini

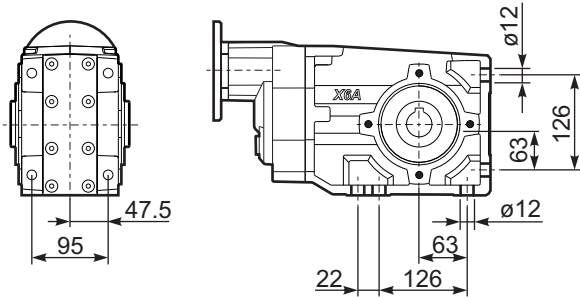

PX63A-F2.. Output flange
Flangia uscita

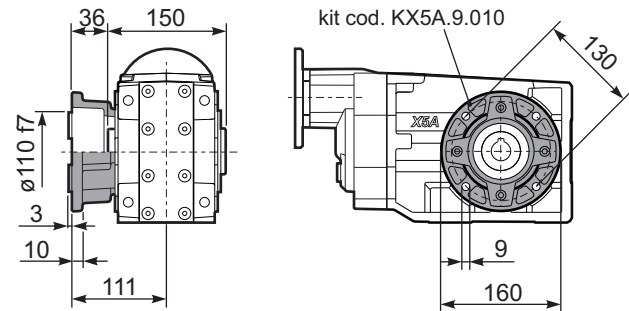

PX63A-F3.. Output flange
Flangia uscita

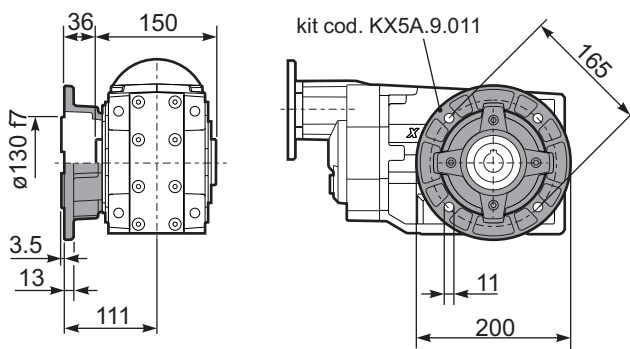

PX63A-F4.. Output flange
Flangia uscita

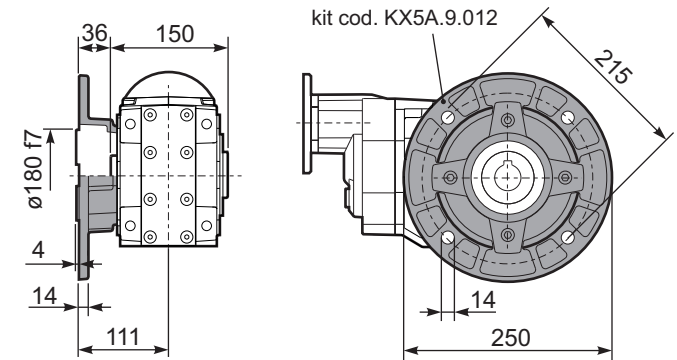

RX63A... Input shaft
Albero in entrata

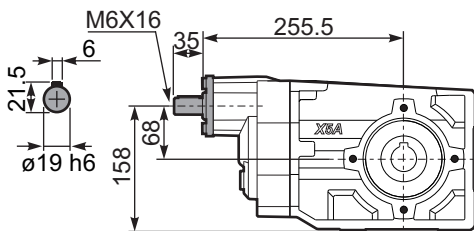

PX63ABR.. Reaction Arm
Braccio di reazione

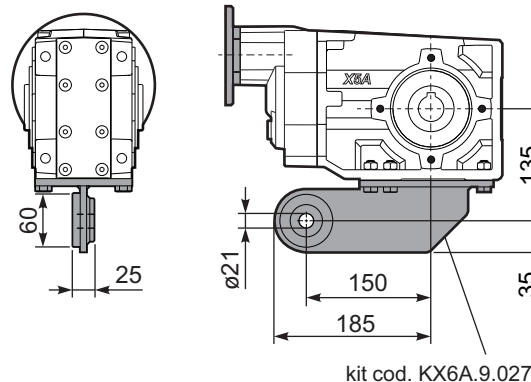

PX63A..A.. Single output shaft
Albero semplice in uscita

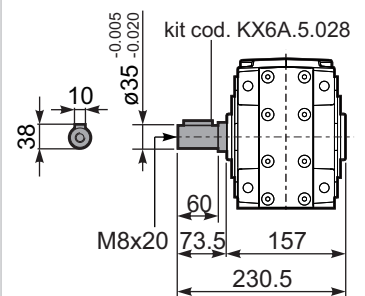

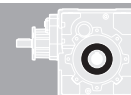

QUICK SELECTION / Selezione veloce

input speed (n_1) = 1400 min⁻¹

Output Speed n_2 [min ⁻¹]	Ratio i	Motor power P_{1M} [kW]	Output torque M_{2M} [Nm]	Service factor f.s.	Nominal power P_{1R} [kW]	Nominal torque M_{2R} [Nm]	Available B5 motor flanges					Available B14 motor flanges				Output Shaft 	Ratios code	
							C	D	E	F	G	R	T	U	V			
							71	80	90	100 112	132	80	90	100 112	132			
176	7.94	7.5	369	1.0	7.5	380	B										302418	01
153	9.13	7.5	425	0.9	6.7	390	B										302416	02
131	10.66	5.5	366	1.1	6.0	410	B										302414	03
94	14.97	5.5	514	1.1	6.0	580	B										202418	04
81	17.21	5.5	591	1.0	5.4	600	B										202416	05
69	20.24	5.5	695	1.0	5.2	675	B										162418	06
60	23.27	4	585	1.2	4.5	675	B										162416	07
53	26.31	4	661	1.0	4.0	675	B										132418	08
46.3	30.25	4	760	0.9	3.5	675	B										132416	09
39.6	35.32	3	668	1.0	3.0	675	B										132414	10
37.8	37.03	3	701	1.0	2.8	675	B										112416	11
32.4	43.23	2.2	602	1.1	2.4	675	B										112414	12
30.1	46.58	2.2	649	1.0	2.3	675	B										82418	13
26.1	53.55	2.2	746	0.9	2.0	675	B										82416	14
22.4	62.52	1.5	600	1.1	1.7	675	B										82414	15
19.0	73.75	1.1	517	1.1	1.2	580	B										62416	16
16.3	86.09	1.1	604	1.1	1.2	675	B										62414	17

The dynamic efficiency is **0.94** for all ratios

Motor Flanges Available
Flange Motore Disponibili

B) Supplied with Reduction Bushing
Fornito con Bussola di Riduzione

B) Available on Request without reduction bushing
Disponibile a Richiesta senza Bussola di Riduzione

C) Motor Flange Holes Position
Posizione Fori Flangia Motore

EN Unit 113C is supplied with synthetic oil for lifetime lubrication, no maintenance is necessary. See table 1 for lubrication and recommended quantity. In table 2 please see possible radial loads and axial loads on the gearbox.

I Il riduttore 113C viene fornito completo di olio sintetico per la lubrificazione permanente e non necessita di alcuna manutenzione. Vedi tab.1 per oli e quantità consigliati. In tab.2 sono presenti i carichi radiali e assiali applicabili al riduttore.

D Das Getriebe 113C ist mit synthetischem Öl gefüllt und ist lebensdauergeschmiert. In Tabelle 1 ist die Schmiermenge und das empfohlene Schmiermittel angegeben. In Tabelle 2 sind die zulässigen Radial - und Axialbelastungen des Getriebes aufgeführt.

F Le réducteur 113C est fourni complet avec de l'huile synthétique pour la lubrification permanente et ne nécessite aucun entretien. Voir tableau 1 concernant les huiles et les quantités conseillées. Les charges radiales et axiales applicables au réducteur sont précisées dans le tableau 2.

E El reductor tamaño 113C se suministra, lubricado de por vida con aceite sintético y no requieren mantenimiento alguna. Ver tabla 1, para cantidades y aceites recomendados. En la tabla 2, se encuentran las cargas radiales y axiales admitidas por el reductor.

Standard supplied	For these mounting position specify in the order or add oil Per queste posizioni specificare in fase d'ordine o aggiungere olio					
4.00 LT	2.60 LT	2.60 LT	2.60 LT	5.15 LT	2.20 LT	Ask
AGIP Telium VSF 320			SHELL Omala S4 WE 320			

For all details on lubrication and plugs check our website [tab. 1](#)
Per maggiori dettagli su lubrificazione e tappi olio vedi il nostro sito web

RADIAL AND AXIAL LOADS

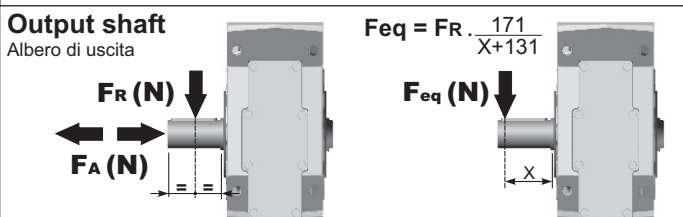

n_2	FA	FR	n_2	FA	FR	n_2	FA	FR
300	640	3200	140	860	4300	70	1080	5400
250	700	3500	120	900	4500	40	1300	6500
200	740	3700	85	1000	5000	15	1840	9200

On request reinforced bearings to increase loads.
A richiesta cuscinetti rinforzati per aumentare i carichi.

Input shaft
Albero in entrata

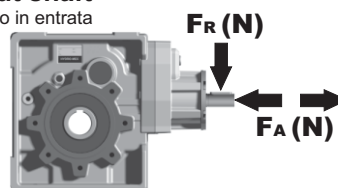

n_1	FA	FR
1400	400	2000
900	440	2200
500	440	2200

tab. 2

P113CC... Basic Gearbox
Riduttore base

Gearbox weight
peso riduttore **38.0 kg**

M. flanges	Kit code	øF	A
71B5	KC023.4.041	160	240.5
80/90B5	KC023.4.042	200	242.5
100/112B5	KC023.4.043	250	251.5
132B5	KC50.4.043	300	269.5
80B14	KC085.4.046	120	242.5
90B14	KC085.4.045	140	242.5
100/112B14	KC085.4.047	160	251.5
132B14	KC50.4.041	200	269.5

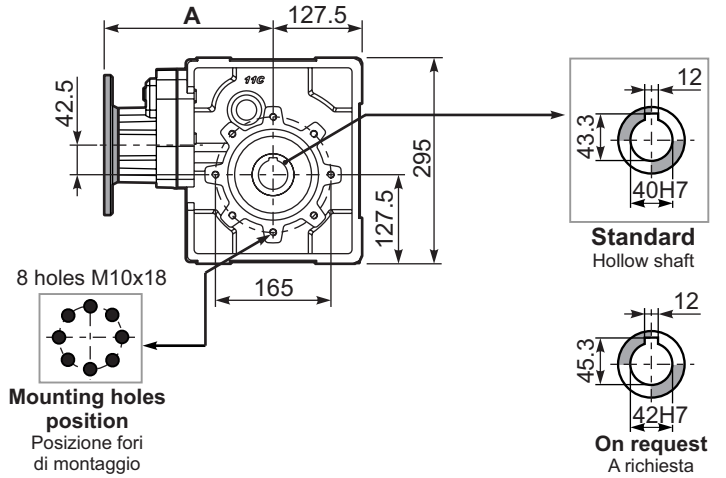
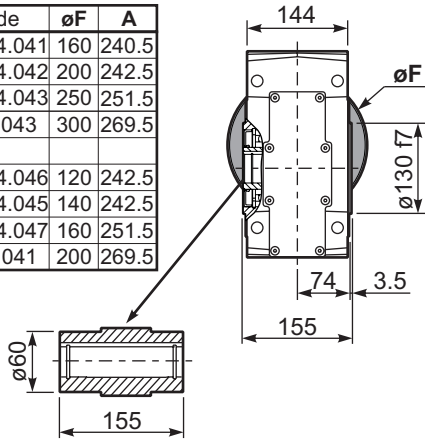

P113C..-N.. Feet
Piedini

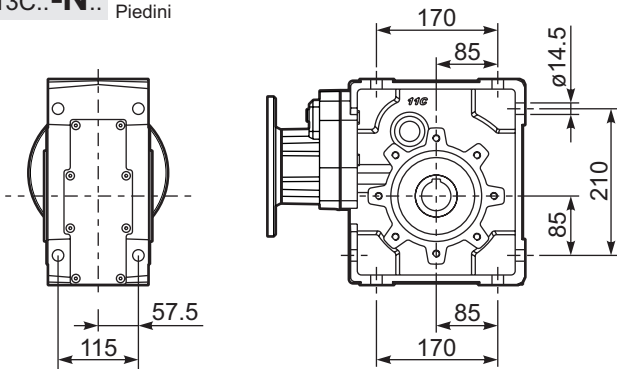

P113C-FC.. Output flange
Flangia uscita

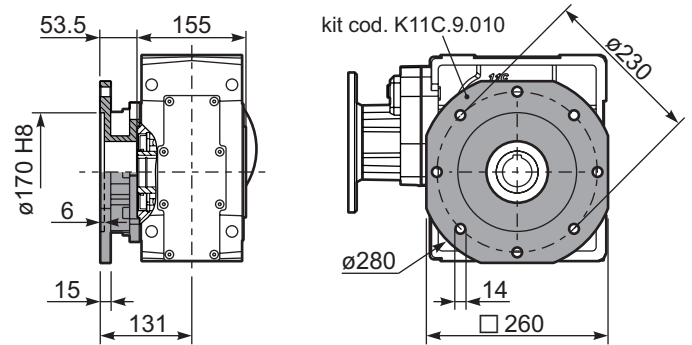

P113C-FL.. Output flange
Flangia uscita

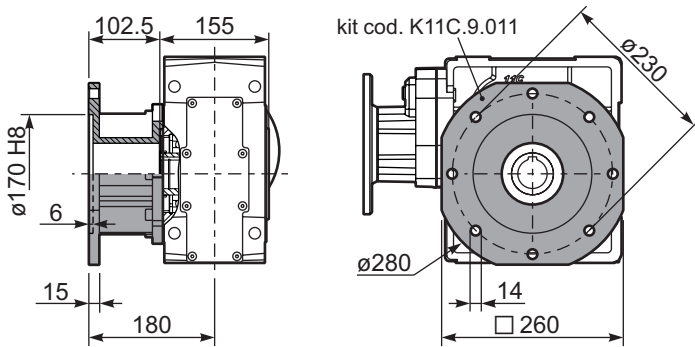

P113CBR.. Reaction Arm
Braccio di reazione

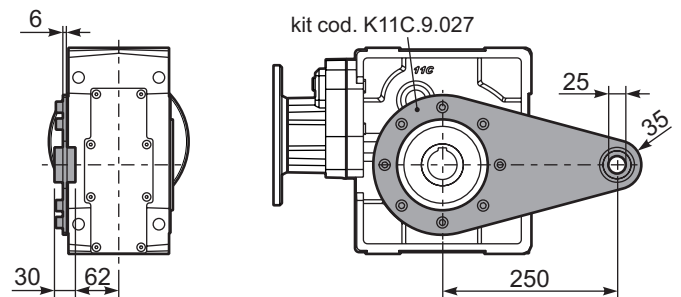

R113C... Input shaft
Albero in entrata

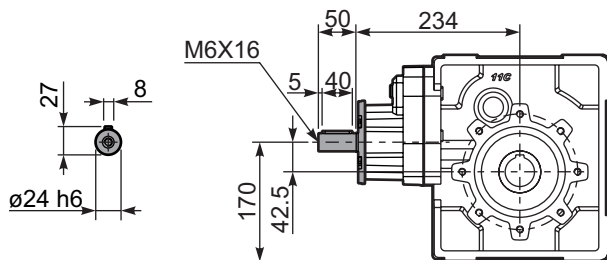

P113C..A.. Single shaft
Albero lento semplice

P113C..B.. Double shaft
Albero lento bisp.

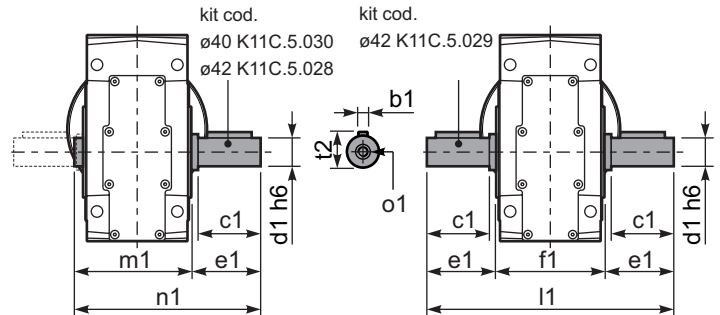

	b1	c1	d1	e1	f1	l1	m1	n1	t2	o1
ø40 Standard	12	80	40	84.5	-	-	164.5	249	43	M12
ø42 On request	12	80	42	84.5	155	324	164.5	249	45	M16

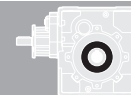

QUICK SELECTION / Selezione veloce

input speed (n_1) = 1400 min⁻¹

Output Speed n_2 [min ⁻¹]	Ratio i	Motor power P_{1M} [kW]	Output torque M_{2M} [Nm]	Service factor f.s.	Nominal power P_{1R} [kW]	Nominal torque M_{2R} [Nm]	Available B5 motor flanges				Available B14 motor flanges			Output Shaft 	Ratios code
							B	C	D	E	Q	R	T		
							63	71	80	90	71	80	90		
18.7	74.79	1.5	704	1.0	1.4	675	B				C	C		19132418	01
16.3	85.99	1.1	591	1.1	1.3	675	B				C	C		19132416	02
14.0	99.66	1.1	685	1.0	1.1	675	B				C	C		17132416	03
12.0	116.35	0.75	548	1.2	0.92	675	B				C	C		17132414	04
11.5	121.45	0.75	572	1.2	0.89	675	B				C	C		13132418	05
10.0	139.64	0.75	658	1.0	0.77	675	B				C	C		13132416	06
9.2	152.21	0.75	717	0.9	0.71	675	B				C	C		19082416	07
8.6	163.02	0.55	567	1.2	0.66	675	B				C	C		13132414	08
7.9	177.69	0.55	618	1.1	0.61	675	B				C	C		19082414	09
6.8	205.95	0.55	716	0.9	0.52	675	B				C	C		17082414	10
6.3	222.52	0.55	774	0.9	0.48	675	B				C	C	On request	10132414	11
5.6	248.76	0.37	578	1.2	0.43	675	B				C	C		9132416	12
4.8	290.41	0.37	675	1.0	0.37	675	B				C	C		9132414	13
4.1	337.39	0.37	784	0.9	0.32	675	B				C	C		10082416	14
3.6	393.88	0.25	618	1.1	0.27	675	B				C	C		10082414	15
3.2	440.33	0.25	690	1.0	0.24	675	B				C	C		9082416	16
2.7	514.06	0.18	616	1.1	0.21	675	B				C	C		9082414	17
2.4	581.44	0.18	697	1.0	0.18	675	B				C	C		7082416	18
2.1	678.79	0.12	526	1.3	0.16	675	B				C	C		7082414	19

The dynamic efficiency is **0.92** for all ratios

A Motor Flanges Available
Flange Motore Disponibili

B Supplied with Reduction Bushing
Fornito con Bussola di Riduzione

B Available on Request without reduction bushing
Disponibile a Richiesta senza Bussola di Riduzione

C Motor Flange Holes Position
Posizione Fori Flangia Motore

EN Unit 114C is supplied with synthetic oil for lifetime lubrication, no maintenance is necessary. See table 1 for lubrication and recommended quantity. In table 2 please see possible radial loads and axial loads on the gearbox.

I Il riduttore 114C viene fornito completo di olio sintetico per la lubrificazione permanente e non necessita di alcuna manutenzione. Vedi tab.1 per oli e quantità consigliati. In tab.2 sono presenti i carichi radiali e assiali applicabili al riduttore.

D Das Getriebe 114C ist mit synthetischem Öl gefüllt und ist lebensdauergeschmiert. In Tabelle 1 ist die Schmiermenge und das empfohlene Schmiermittel angegeben. In Tabelle 2 sind die zulässigen Radial - und Axialbelastungen des Getriebes aufgeführt.

F Le réducteur 114C est fourni complet avec de l'huile synthétique pour la lubrification permanente et ne nécessite aucun entretien. Voir tableau 1 concernant les huiles et les quantités conseillées. Les charges radiales et axiales applicables au réducteur sont précisées dans le tableau 2.

E El reductor tamaño 114C se suministra, lubricado de por vida con aceite sintético y no requieren mantenimiento alguna. Ver tabla 1, para cantidades y aceites recomendados. En la tabla 2, se encuentran las cargas radiales y axiales admitidas por el reductor.

Standard supplied	For these mounting position specify in the order or add oil Per queste posizioni specificare in fase d'ordine o aggiungere olio					
4.10 LT	2.70 LT	2.70 LT	2.70 LT	5.30 LT	2.35 LT	Ask
AGIP Telium VSF 320				SHELL Omala S4 WE 320		

For all details on lubrication and plugs check our website **tab. 1**
Per maggiori dettagli su lubrificazione e tappi olio vedi il nostro sito web

RADIAL AND AXIAL LOADS

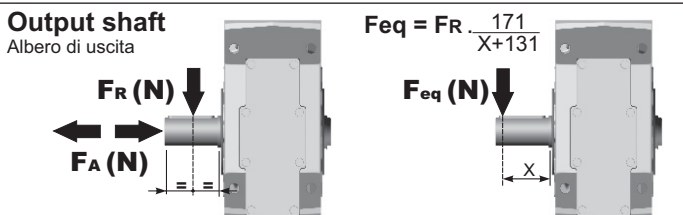

n_2	FA	FR	n_2	FA	FR	n_2	FA	FR
300	640	3200	140	860	4300	70	1080	5400
250	700	3500	120	900	4500	40	1300	6500
200	740	3700	85	1000	5000	15	1840	9200

On request reinforced bearings to increase loads.
A richiesta cuscinetti rinforzati per aumentare i carichi.

Input shaft
Albero in entrata

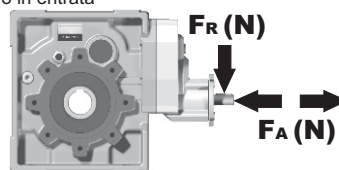

n_1	FA	FR
1400	240	1200
900	280	1400
500	310	1700

tab. 2

P114CC... Basic Gearbox
Riduttore base

Gearbox weight
peso riduttore **38.0 kg**

M. flanges	Kit code	øF	A
63B5	K063.4.041	140	252.5
71B5	K063.4.042	160	250.5
80/90B5	K063.4.043	200	252.5
71B14	K063.4.047	105	250.5
80B14	K063.4.046	120	252.5
90B14	K063.4.041	140	252.5

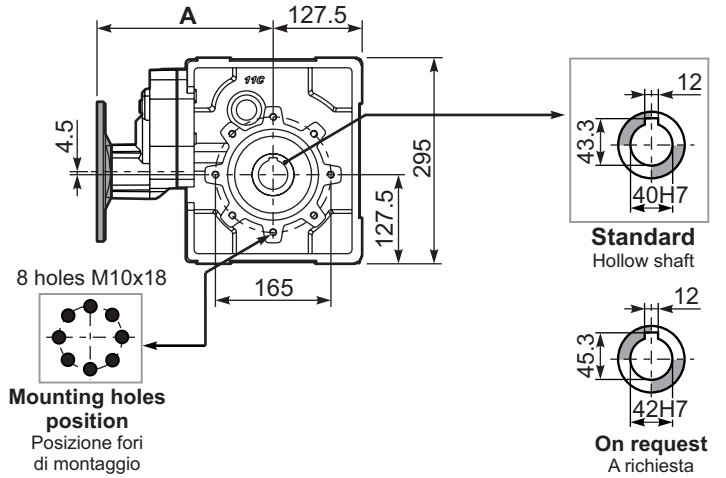
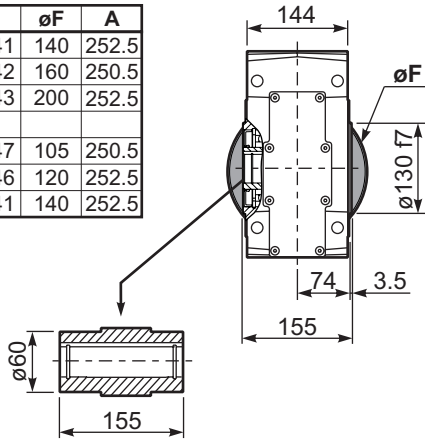

P114C..-N.. Feet
Piedini

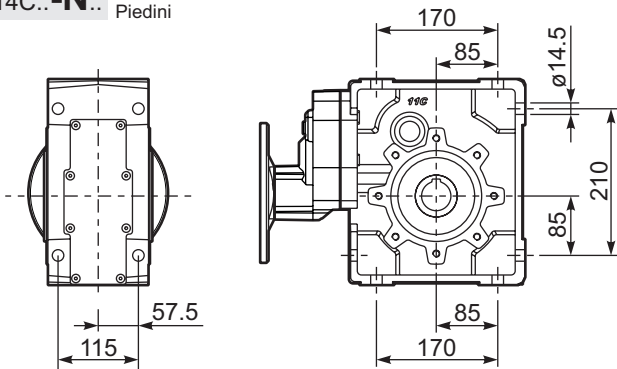

P114C-FC.. Output flange
Flangia uscita

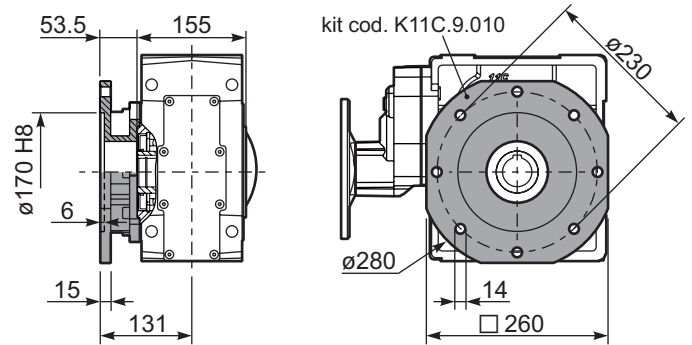

P114C-FL.. Output flange
Flangia uscita

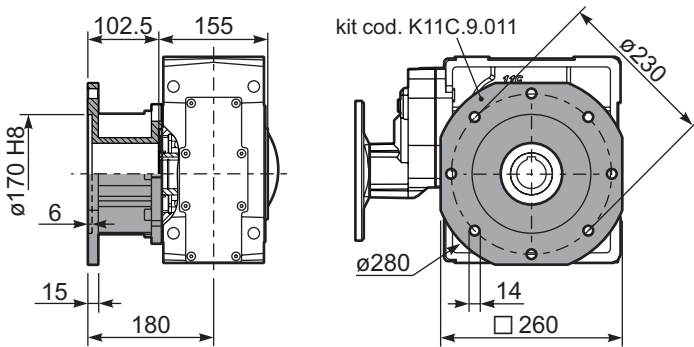

P114CBR.. Reaction Arm
Braccio di reazione

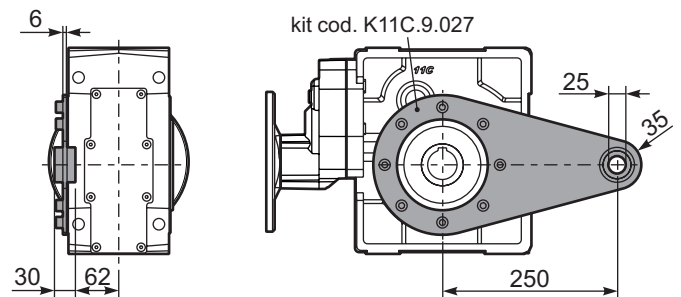

R114C... Input shaft
Albero in entrata

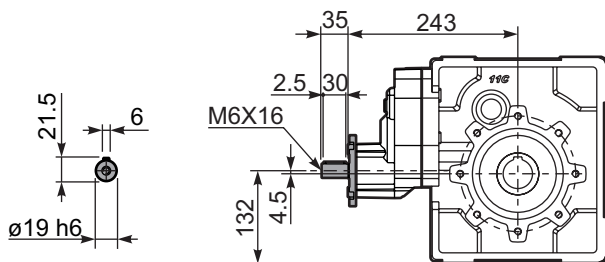

P114C..A.. Single shaft
Albero lento semplice

P114C..B.. Double shaft
Albero lento bisp.

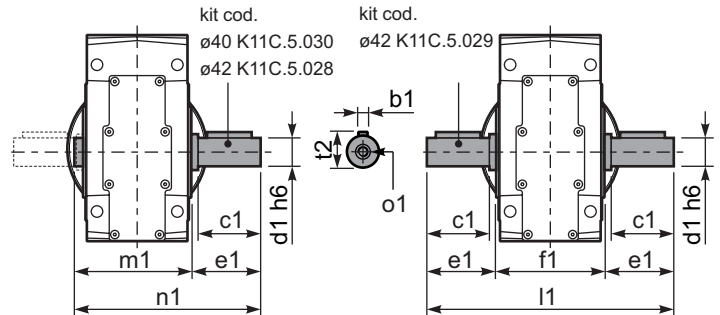

	b1	c1	d1	e1	f1	l1	m1	n1	t2	o1
ø40 Standard	12	80	40	84.5	-	-	164.5	249	43	M12
ø42 On request	12	80	42	84.5	155	324	164.5	249	45	M16

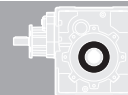

QUICK SELECTION / Selezione veloce

input speed (n_1) = 1400 min⁻¹

Output Speed n_2 [min ⁻¹]	Ratio i	Motor power P_{1M} [kW]	Output torque M_{2M} [Nm]	Service factor $f.s.$	Nominal power P_{1R} [kW]	Nominal torque M_{2R} [Nm]	Available B5 motor flanges					Available B14 motor flanges				Output Shaft \varnothing	Ratios code 	
							C	D	E	F	G	R	T	U	V			
							71	80	90	100 112	132	80	90	100 112	132			
145	9.69	9	560	1.3	12.2	755	B										302418	01
126	11.09	9	641	1.1	9.6	680	B										302416	02
108	12.90	9	746	1.1	9.6	790	B										302414	03
77	18.26	7.5	849	1.1	8.0	935	B										202418	04
67	20.91	7.5	972	1.0	7.5	1000	B										202416	05
58	24.32	5.5	835	1.2	6.4	1000	B										202414	06
49.5	28.27	5.5	971	1.0	5.5	1000	B										162416	07
42.6	32.88	4	826	1.2	4.7	1000	B										162414	08
38.1	36.76	4	924	1.1	4.2	1000	B										132416	09
32.7	42.76	3	809	1.2	3.6	1000	B										132414	10
31.1	45.00	3	851	1.2	3.5	1000	B										112416	11
26.8	52.33	3	990	1.0	3.0	1000	B										112414	12
24.6	56.82	2.2	791	1.1	2.3	850	B										82418	13
21.5	65.07	2.2	906	1.1	2.3	975	B										82416	14
18.5	75.68	2.2	1054	0.9	2.1	1000	B										82414	15
15.6	89.61	1.1	628	1.1	1.2	710	B										62416	16
13.4	104.22	1.1	731	1.1	1.2	820	B										62414	17

The dynamic efficiency is **0.94** for all ratios

Motor Flanges Available
Flange Motore Disponibili

B) Supplied with Reduction Bushing
Fornito con Bussola di Riduzione

B) Available on Request without reduction bushing
Disponibile a Richiesta senza Bussola di Riduzione

C) Motor Flange Holes Position
Posizione Fori Flangia Motore

EN Unit 133C is supplied without lubricant and equipped with a breather, level and drain plugs. User can add mineral oil keeping existing plugs. Should the user wish to fill it with synthetic oil, it is recommended to replace the existing plugs with a closed plug. See table 1 for lubrication and recommended quantity. In table 2 please see possible radial loads and axial loads on the gearbox.

I Il riduttore tipo 133C è fornito privo di lubrificazione con tappi di sfiato, livello e scarico olio. L'utente può immettere olio minerale mantenendo i tappi esistenti. Se immetterà olio sintetico, dovrà sostituire i tappi esistenti con altri tipo chiuso. Tab.1 per oli e quantità consigliati. Tab.2 carichi radiali e assiali applicabili al riduttore.

D Das Getriebe der Baugröße 133C wird ohne Schmiermittel geliefert. Es ist jedoch mit Einfüllschraube, Überdruckventil und Ablassschraube ausgerüstet. Das benötigte mineralische Öl kann über die Einfüllschraube eingefüllt werden. Sollte synthetisches Öl bevorzugt werden, so ist sind das eingebaute Überdruckventil durch eine geschlossenen Schraube zu ersetzen. In Tabelle 1 ist die Schmiermenge und das empfohlene Schmiermittel angegeben. In Tabelle 2 sind die zulässigen Radial - und Axialbelastungen des Getriebes aufgeführt.

F Le réducteur de type 133C est fourni sans lubrification et avec un bouchon de remplissage, de niveau et d'évacuation de l'huile. L'utilisateur peut verser de l'huile minérale en conservant les bouchons existants. S'il y versera de l'huile synthétique, il devra substituer les bouchons existants avec d'autres bouchons de type fermé. Voir tableau 1 concernant les huiles et les quantités conseillées. Voir tableau 2 concernant les charges radiales et axiales applicables au réducteur.

E El reductor tamaño 133C se suministra sin lubricante, provisto de tapones de respiración, nivel y descarga de aceite. El usuario puede utilizar aceite mineral, manteniendo los tapones existentes. Si prefiere utilizar aceite sintético deberá sustituir los tapones existentes por tapones ciegos. La prerreducción se suministra con tapones ciegos, lubricado de por vida con aceite sintético. Ver tabla 1, para cantidades y aceites recomendados. En la tabla 2, se encuentran las cargas radiales y axiales admitidas por el reductor.

B3	B6	B7	B8	V5	V6	V8
6.00 LT	4.30 LT	4.30 LT	3.30 LT	7.40 LT	3.10 LT	Ask

AGIP Blasias 460

For all details on lubrication and plugs check our website [tab. 1](#)
Per maggiori dettagli su lubrificazione e tappi olio vedi il nostro sito web

RADIAL AND AXIAL LOADS

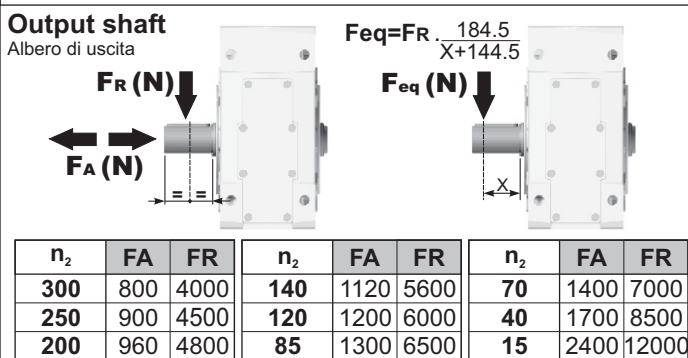

On request reinforced bearings to increase loads.

A richiesta cuscinetti rinforzati per aumentare i carichi.

Input shaft

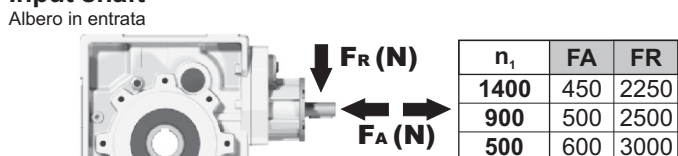

tab. 2

P133CC... Basic gearbox
Riduttore base

Gearbox weight
peso riduttore **53.5 kg**

M. flanges	Kit code	øF	A
71B5	KC023.4.041	160	251
80/90B5	KC023.4.042	200	253
100/112B5	KC023.4.043	250	262
132B5	KC50.4.043	300	280
80B14	KC085.4.046	120	253
90B14	KC085.4.045	140	253
100/112B14	KC085.4.047	160	262
132B14	KC50.4.041	200	280

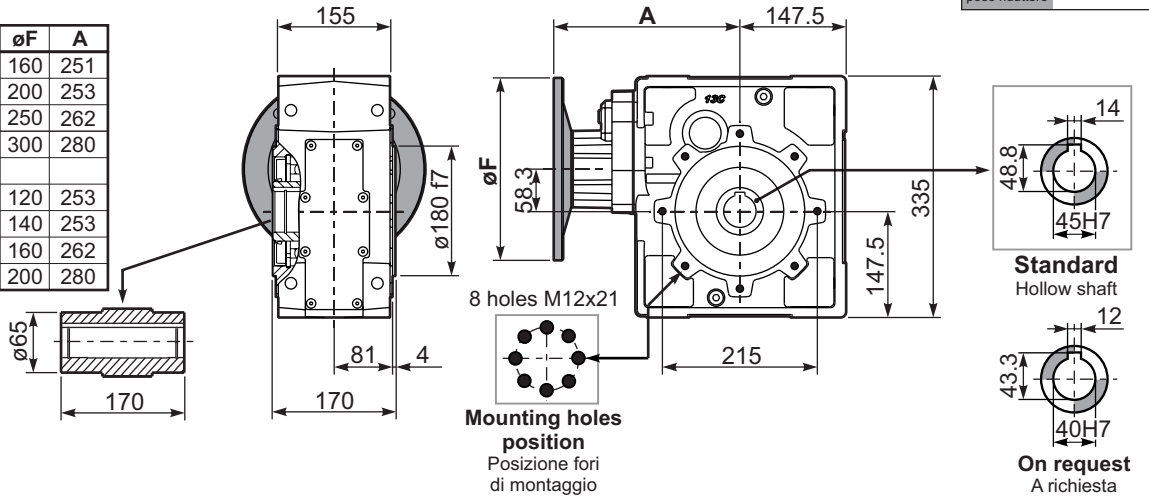

P133C..-N.. Feet
Piedini

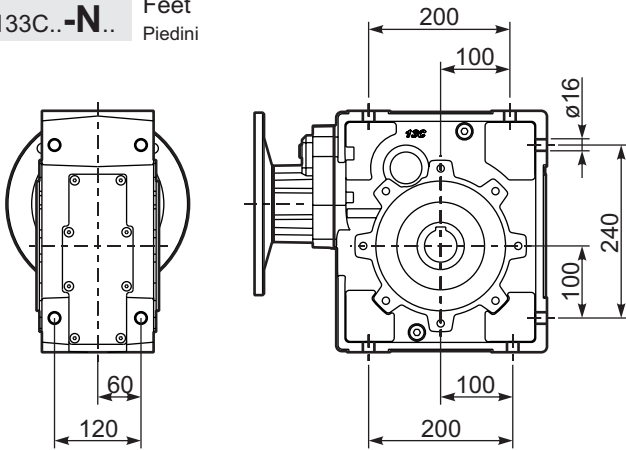

P133C..-FC.. Output flange
Flangia uscita

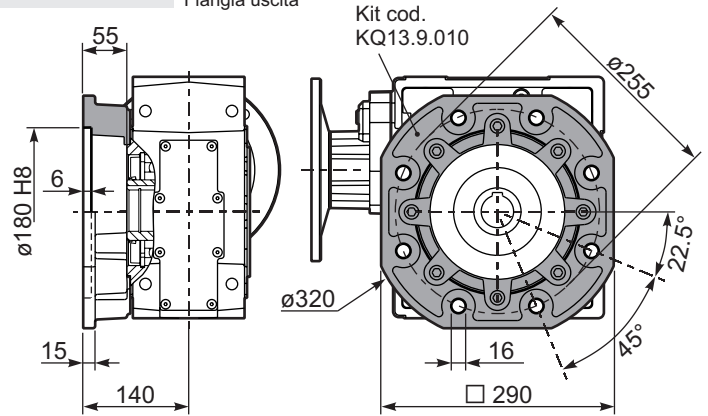

R133C... Input Shaft
Albero in entrata

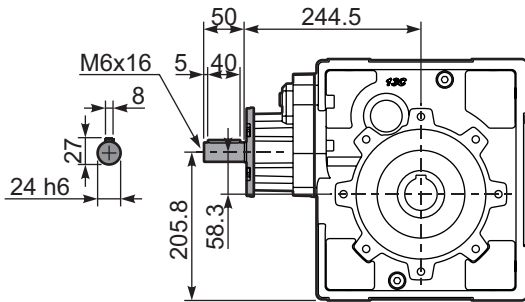

P133CBR.. Reaction arm
Braccio di reazione

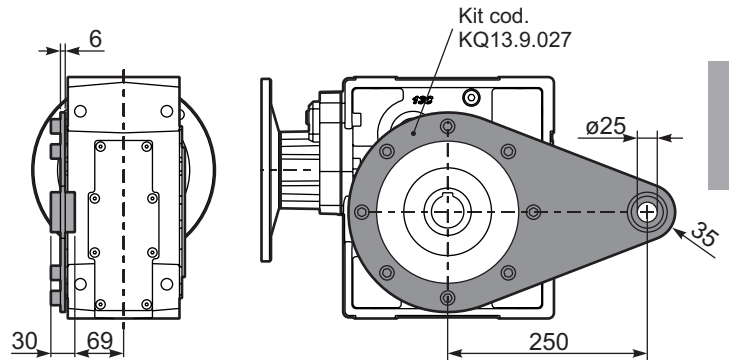

P133C..A.. Single output Shaft
Albero lento semplice

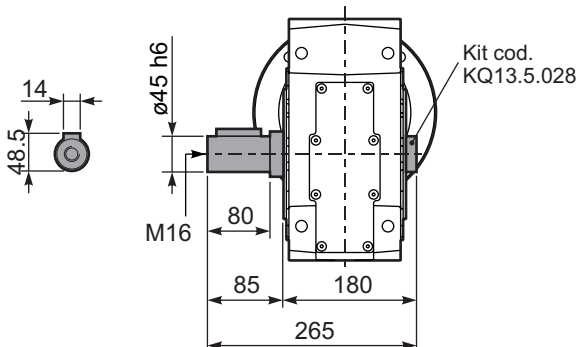

P133C..B.. Double Input Shaft
Albero lento bisporgente

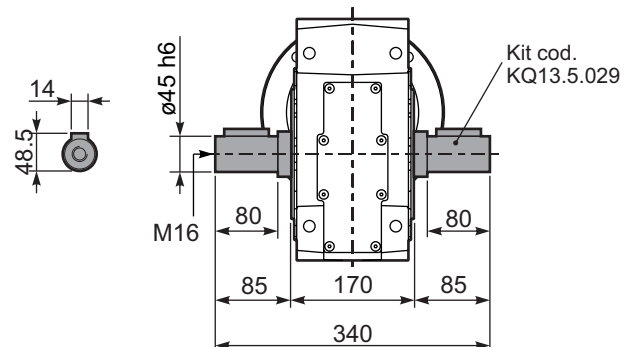

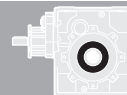

QUICK SELECTION / Selezione veloce

input speed (n_1) = 1400 min⁻¹

Output Speed n_2 [min ⁻¹]	Ratio i	Motor power P_{1M} [kW]	Output torque M_{2M} [Nm]	Service factor f.s.	Nominal power P_{1R} [kW]	Nominal torque M_{2R} [Nm]	Available B5 motor flanges				Available B14 motor flanges			Output Shaft 	Ratios code
							B	C	D	E	Q	R	T		
							63	71	80	90	71	80	90		
15.3	91.23	1.5	858	1.2	1.7	1000	B				C	C		19132418	01
13.4	104.48	1.5	983	1.0	1.5	1000	B				C	C		19132416	02
11.6	121.10	1.5	1139	0.9	1.3	1000	B				C	C		17132416	03
9.9	140.84	1.1	968	1.0	1.1	1000	B				C	C		17132414	04
8.5	165.32	1.1	1136	0.9	0.96	1000	B				C	C		15132414	05
7.6	184.94	0.75	872	1.1	0.86	1000	B				C	C		19082416	06
7.1	197.34	0.75	930	1.1	0.81	1000	B				C	C		13132414	07
6.5	215.10	0.75	1014	1.0	0.74	1000	B				C	C		19082414	08
6.0	231.60	0.55	805	1.2	0.69	1000	B				C	C		10132416	09
5.6	249.31	0.55	867	1.2	0.64	1000	B				C	C		17082414	10
5.2	269.37	0.55	937	1.1	0.59	1000	B				C	C		10132414	11
4.8	292.64	0.55	1018	1.0	0.54	1000	B				C	C		15082414	12
4.6	302.26	0.55	1051	1.0	0.53	1000	B				C	C		9132416	13
4.0	349.30	0.37	812	1.2	0.46	1000	B				C	C		13082414	14
3.5	399.12	0.37	928	1.1	0.40	1000	B				C	C		7132416	15
2.9	476.80	0.37	1108	0.9	0.33	1000	B				C	C		10082414	16
2.2	622.28	0.25	976	1.0	0.26	1000	B				C	C		9082414	17
1.7	821.70	0.18	985	1.0	0.19	1000	B				C	C		7082414	18

The dynamic efficiency is **0.92** for all ratios

Motor Flanges Available
Flange Motore Disponibili

B) Supplied with Reduction Bushing
Fornito con Bussola di Riduzione

B) Available on Request without reduction bushing
Disponibile a Richiesta senza Bussola di Riduzione

C) Motor Flange Holes Position
Posizione Fori Flangia Motore

EN Unit **134C** is supplied without lubricant and equipped with a breather, level and drain plugs. User can add mineral oil keeping existing plugs. Should the user wish to fill it with synthetic oil, it is recommended to replace the existing plugs with a closed plug.
See table 1 for lubrication and recommended quantity.
In table 2 please see possible radial loads and axial loads on the gearbox.

I Il riduttore tipo **134C** è fornito privo di lubrificazione con tappi di sfiato, livello e scarico olio. L'utente può immettere olio minerale mantenendo i tappi esistenti. Se immetterà olio sintetico, dovrà sostituire i tappi esistenti con altri tipo chiuso.
Tab.1 per oli e quantità consigliati.
Tab.2 carichi radiali e assiali applicabili al riduttore.

D Das Getriebe der Baugröße **134C** wird ohne Schmiermittel geliefert. Es ist jedoch mit Einfüllschraube, Überdruckventil und Ablassschraube ausgerüstet. Das benötigte mineralische Öl kann über die Einfüllschraube eingefüllt werden. Sollte synthetisches Öl bevorzugt werden, so ist sind das eingebaute Überdruckventil durch eine geschlossenen Schraube zu ersetzen.
In Tabelle 1 ist die Schmiermenge und das empfohlene Schmiermittel angegeben
In Tabelle 2 sind die zulässigen Radial - und Axialbelastungen des Getriebes aufgeführt.

F Le réducteur de type **134C** est fourni sans lubrification et avec un bouchon de remplissage, de niveau et d'évacuation de l'huile. L'utilisateur peut y verser de l'huile minérale en conservant les bouchons existants.
S'il y versera de l'huile synthétique, il devra substituer les bouchons existants avec d'autres bouchons de type fermé.
Voir tableau 1 concernant les huiles et les quantités conseillées.
Voir tableau 2 concernant les charges radiales et axiales applicables au réducteur

E El reductor tamaño **134C** se suministra sin lubricante, provisto de tapones de respiración, nivel y descarga de aceite. El usuario puede utilizar aceite mineral, manteniendo los tapones existentes. Si prefiere utilizar aceite sintético deberá sustituir los tapones existentes por tapones ciegos. La prerreducción se suministra con tapones ciegos, lubricado de por vida con aceite sintético.
Ver tabla 1, para cantidades y aceites recomendados. En la tabla 2, se encuentran las cargas radiales y axiales admitidas por el reductor.

B3	B6	B7	B8	V5	V6	V8
6.10 LT	4.40 LT	4.40 LT	3.40 LT	7.50 LT	3.20 LT	Ask

AGIP Blasias 460

For all details on lubrication and plugs check our website **tab. 1**
Per maggiori dettagli su lubrificazione e tappi olio vedi il nostro sito web

RADIAL AND AXIAL LOADS

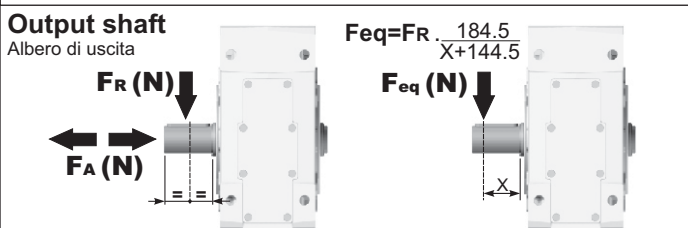

n_2	FA	FR	n_2	FA	FR	n_2	FA	FR
300	800	4000	140	1120	5600	70	1400	7000
250	900	4500	120	1200	6000	40	1700	8500
200	960	4800	85	1300	6500	15	2400	12000

On request reinforced bearings to increase loads.
A richiesta cuscinetti rinforzati per aumentare i carichi.

Input shaft
Albero in entrata

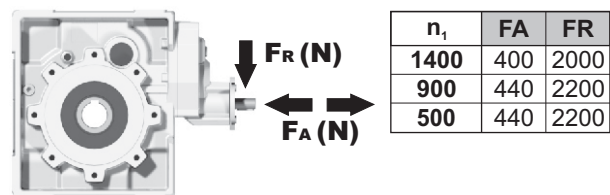

n_1	FA	FR
1400	400	2000
900	440	2200
500	440	2200

tab. 2

P134CC... Basic gearbox
Riduttore base

Gearbox weight
peso riduttore **53.5 kg**

M. flanges	Kit code	øF	A
63B5	K063.4.041	140	263
71B5	K063.4.042	160	261
80/90B5	K063.4.043	200	263
71B14	K063.4.047	105	261
80B14	K063.4.046	120	263
90B14	K063.4.041	140	263

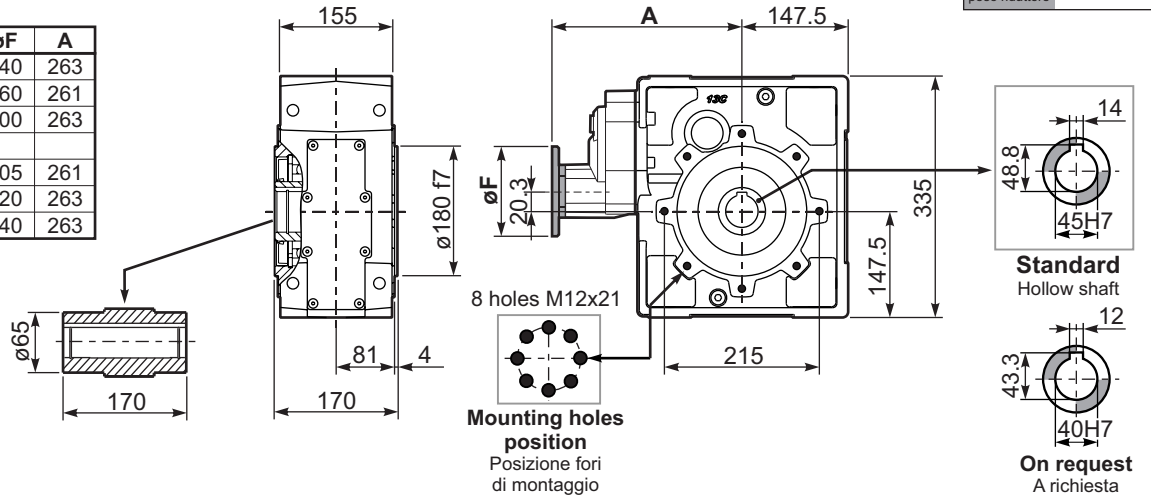

P134C...-N... Feet
Piedini

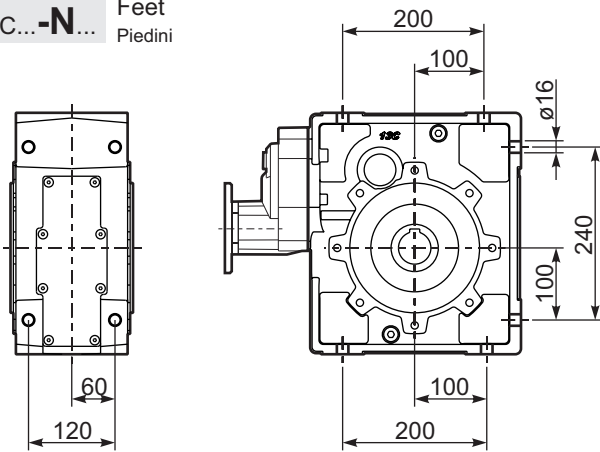

P134C...-FC.. Output flange
Flangia uscita

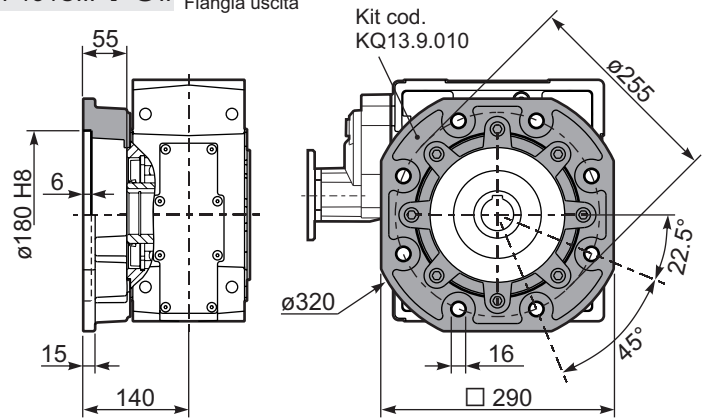

R134C... Input Shaft
Albero in entrata

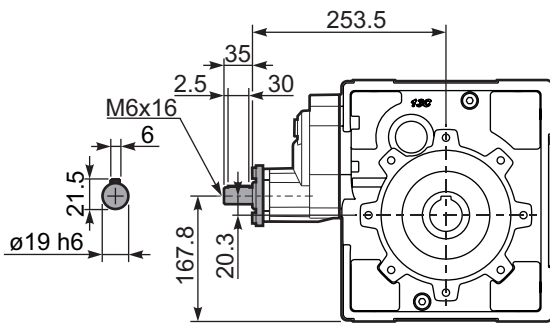

P134CBR.. Reaction arm
Braccio di reazione

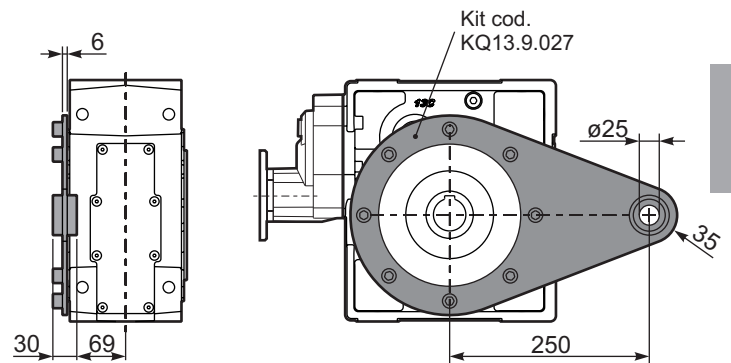

P134C..A.. Single output Shaft
Albero lento semplice

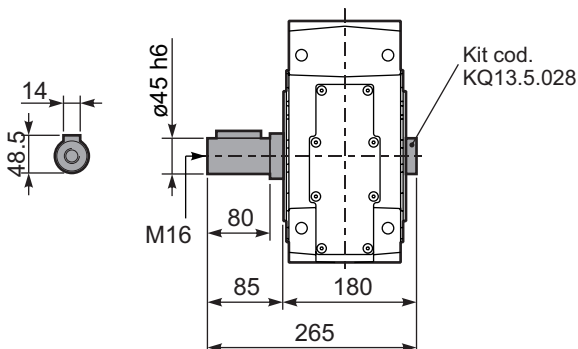

P134C..B.. Double Input Shaft
Albero lento bisporgente

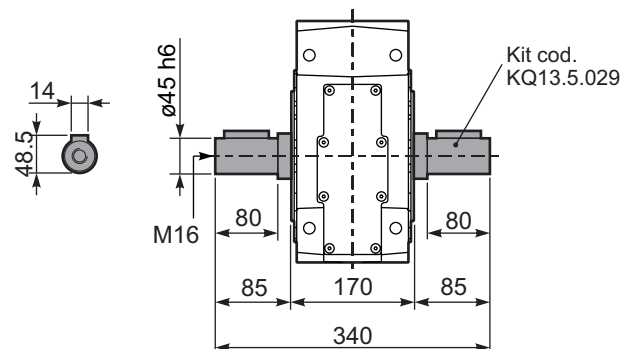

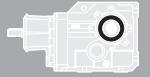

QUICK SELECTION / Selezione veloce

input speed (n_1) = 1400 min⁻¹

Output Speed n_2 [min ⁻¹]	Ratio i	Motor power P_{1M} [kW]	Output torque M_{2M} [Nm]	Service factor f.s.	Nominal power P_{1R} [kW]	Nominal torque M_{2R} [Nm]	B5 motor flanges				B14 motor flanges				Output Shaft 	Ratios code
							F	G	H	I	-	-	-	-		
							100 112	132	160	180	-	-	-	-		
236	5.94	22	806	1.0	21.0	800	B							302915	standard ø50 ø45 On request	01
196	7.13	18.5	812	1.0	17.9	820	B							302913		02
163	8.58	18.5	977	1.0	17.3	950	B							302911		03
125	11.20	15	1033	1.0	13.9	1000	B							202915		04
104	13.43	15	1239	1.1	15.7	1350	B							202913		05
92	15.15	15	1397	1.0	14.4	1400	B							162915		06
87	16.17	15	1492	1.0	14.0	1450	B							202911		07
77	18.16	15	1675	0.9	13.3	1550	B							162913		08
71	19.70	11	1335	1.2	12.3	1550	B							132915		09
64	21.87	11	1482	1.1	11.4	1600	B							162911		10
59	23.62	11	1600	1.0	10.6	1600	B							132913		11
48.4	28.91	9	1671	1.0	8.6	1600	B							112913		12
40.2	34.81	7.5	1618	1.0	7.2	1600	B							112911		13
33.5	41.81	5.5	1436	1.1	6.0	1600	B							82913		14
27.8	50.34	5.5	1729	0.9	5.0	1600	B							82911		15

The dynamic efficiency is **0.94** for all ratios

- Motor Flanges Available** Flange Motore Disponibili
- B) Supplied with Reduction Bushing** Fornito con Bussola di Riduzione
- B) Available on Request without reduction bushing** Disponibile a Richiesta senza Bussola di Riduzione
- C) Motor Flange Holes Position** Posizione Fori Flangia Motore

EN Unit **X93C** is supplied without lubricant and equipped with a breather, level and drain plugs. User can add mineral oil keeping existing plugs. Should the user wish to fill it with synthetic oil, it is recommended to replace the existing plugs with a closed plug. See table 1 for lubrication and recommended quantity. In table 2 please see possible radial loads and axial loads on the gearbox.

I Il riduttore tipo **X93C** è fornito privo di lubrificazione con tappi di sfiato, livello e scarico olio. L'utente può immettere olio minerale mantenendo i tappi esistenti. Se immetterà olio sintetico, dovrà sostituire i tappi esistenti con altri tipo chiuso. Tab.1 per oli e quantità consigliati. Tab.2 carichi radiali e assiali applicabili al riduttore.

D Das Getriebe der Baugröße **X93C** wird ohne Schmiermittel geliefert. Es ist jedoch mit Einfüllschraube, Überdruckventil und Ablassschraube ausgerüstet. Das benötigte mineralische Öl kann über die Einfüllschraube eingefüllt werden. Sollte synthetisches Öl bevorzugt werden, so ist sind das eingebaute Überdruckventil durch eine geschlossenen Schraube zu ersetzen. In Tabelle 1 ist die Schmiermenge und das empfohlene Schmiermittel angegeben. In Tabelle 2 sind die zulässigen Radial - und Axialbelastungen des Getriebes aufgeführt.

F Le réducteur de type **X93C** est fourni sans lubrification et avec un bouchon de remplissage, de niveau et d'évacuation de l'huile. L'utilisateur peut y verser de l'huile minérale en conservant les bouchons existants. S'il y versera de l'huile synthétique, il devra substituer les bouchons existants avec d'autres bouchons de type fermé. Voir tableau 1 concernant les huiles et les quantités conseillées. Voir tableau 2 concernant les charges radiales et axiales applicables au réducteur.

E El reductor tamaño **X93C** se suministra sin lubricante, provisto de tapones de respiración, nivel y descarga de aceite. El usuario puede utilizar aceite mineral, manteniendo los tapones existentes. Si prefiere utilizar aceite sintético deberá sustituir los tapones existentes por tapones ciegos. La prerreducción se suministra con tapones ciegos, lubricado de por vida con aceite sintético. Ver tabla 1, para cantidades y aceites recomendados. En la tabla 2, se encuentran las cargas radiales y axiales admitidas por el reductor.

Standard supplied	For these mounting position specify in the order or add oil Per queste posizioni specificare in fase d'ordine o aggiungere olio					
B3	B6	B7	B8	V5	V6	V8
4.30 LT	3.70 LT	4.50 LT	5.10 LT	7.40 LT	5.30 LT	Ask
AGIP Blasias 460						

For all details on lubrication and plugs check our website [tab. 1](#)
Per maggiori dettagli su lubrificazione e tappi olio vedi il nostro sito web

RADIAL AND AXIAL LOADS

Output shaft
Albero di uscita

$F_{eq} = FR \cdot \frac{178.5}{X+228.5}$

n_2	FA	FR	n_2	FA	FR	n_2	FA	FR
300	1800	9000	140	2700	13500	70	3020	15100
250	2400	12000	120	2800	14000	40	3200	16000
200	2600	13000	85	2900	14500	15	3500	17500

Input shaft
Albero in entrata

n_1	FA	FR
1400	700	3500
900	840	4200
500	900	4500

tab. 2

PX93CC... Basic Gearbox
Riduttore base

Gearbox weight
peso riduttore **75.0 kg**

M. flanges	Kit code	øF	A
100/112B5	-	250	381
132B5	-	300	385
160/180B5	-	350	396

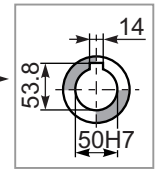
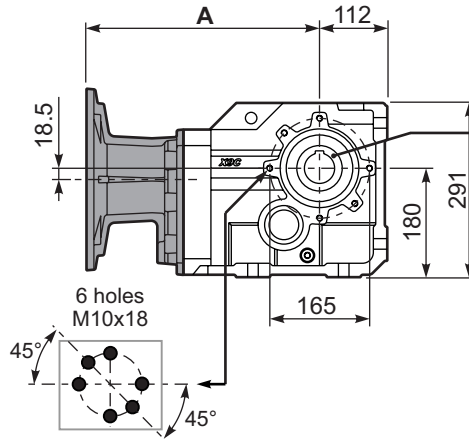
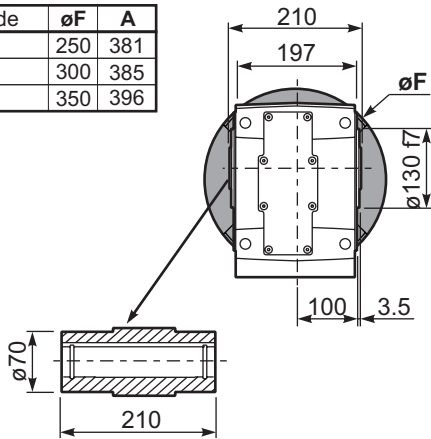

Standard
Hollow shaft

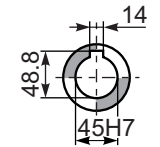

On request
A richiesta

Mounting holes position
Posizione fori di montaggio

PX93C...FB.. Feet
Piedini

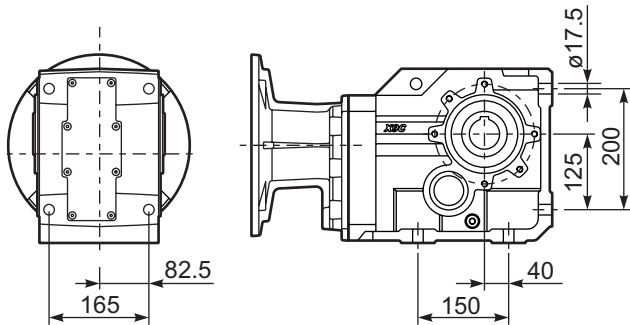

PX93C...-FC.. Output flange
Flangia uscita

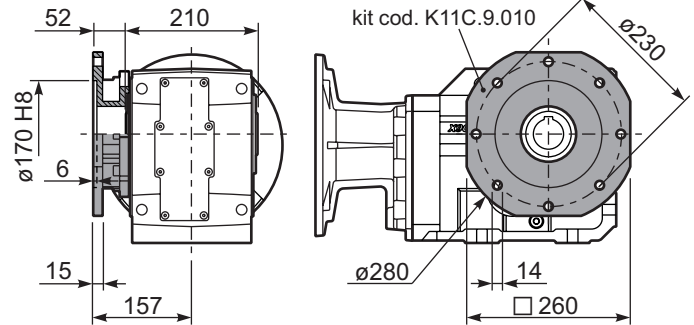

PX93C...-FL.. Output flange
Flangia uscita

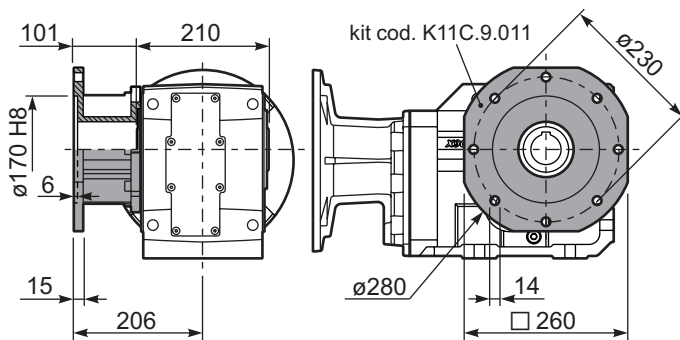

PX93C...BR.. Reaction Arm
Braccio di reazione

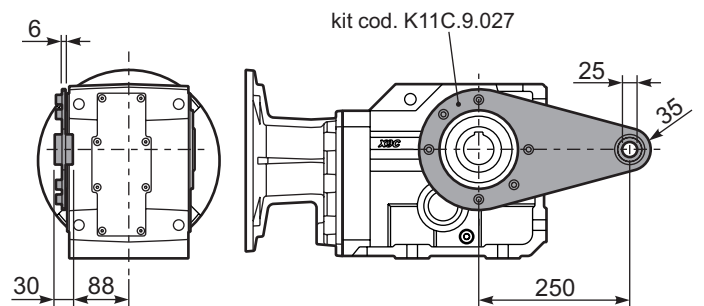

RX93C... Input shaft
Albero in entrata

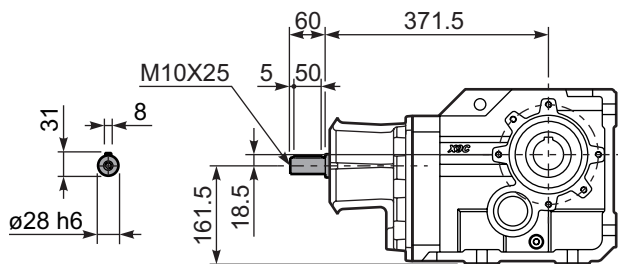

PX93CA... Single shaft
Albero lento semplice

PX93CB... Double shaft
Albero lento bisp.

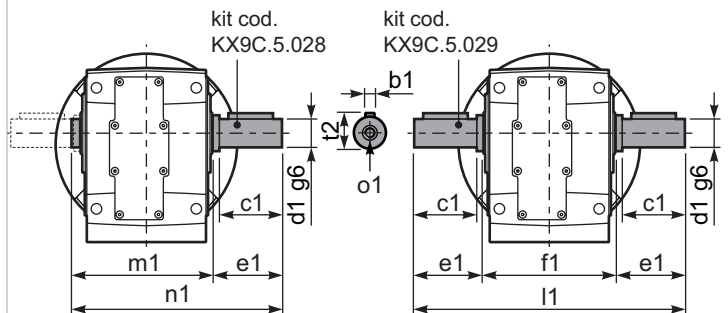

	b1	c1	d1	e1	f1	l1	m1	n1	t2	o1
Standard	14	100	50	105	210	420	218	323	53.5	M16
-	-	-	-	-	-	-	-	-	-	-



QUICK SELECTION / Selezione veloce

input speed (n_1) = 1400 min⁻¹

Output Speed n_2 [min ⁻¹]	Ratio i	Motor power P_{1M} [kW]	Output torque M_{2M} [Nm]	Service factor f.s.	Nominal power P_{1R} [kW]	Nominal torque M_{2R} [Nm]	Available B5 motor flanges					Available B14 motor flanges				Output Shaft 	Ratios code
							C	D	E	F	G	R	T	U	V		
							71	80	90	100 112	132	80	90	100 112	132		
45.6	30.70	7.5	1399	1.1	8.3	1600	B									30132913	01
37.9	36.97	7.5	1685	0.9	6.9	1600	B									30132911	02
29.0	48.26	5.5	1625	1.0	5.3	1600	B									20132915	03
24.2	57.86	4	1425	1.1	4.4	1600	B									20132913	04
21.5	65.24	4	1607	1.0	3.9	1600	B									16132915	05
20.1	69.68	4	1716	1.0	3.8	1650	B									20132911	06
17.9	78.23	3	1450	1.1	3.4	1650	B									16132913	07
16.5	84.85	3	1573	1.0	3.0	1600	B									13132915	08
14.9	94.20	3	1747	0.9	2.8	1650	B									16132911	09
13.8	101.74	3	1886	0.9	2.6	1650	B									13132913	10
11.4	122.51	2.2	1672	1.0	2.1	1650	B									13132911	11
9.3	149.95	1.5	1411	1.2	1.8	1650	B									11132911	12
7.8	180.09	1.5	1694	1.0	1.5	1650	B									8132913	13
6.8	206.81	1.1	1421	1.1	1.2	1600	B									6132915	14
6.5	216.85	1.1	1490	1.1	1.2	1650	B									8132911	15
5.6	247.99	1.1	1704	1.0	1.1	1650	B									6132913	16
4.7	298.61	0.75	1407	1.2	0.88	1650	B									6132911	17

The dynamic efficiency is **0.92** for all ratios

- Motor Flanges Available
Flange Motore Disponibili
- B) Supplied with Reduction Bushing
Fornito con Bussola di Riduzione
- B) Available on Request without reduction bushing
Disponibile a Richiesta senza Bussola di Riduzione
- C) Motor Flange Holes Position
Posizione Fori Flangia Motore

EN Unit **X94C** is supplied without lubricant and equipped with a breather, level and drain plugs. User can add mineral oil keeping existing plugs. Should the user wish to fill it with synthetic oil, it is recommended to replace the existing plugs with a closed plug. See table 1 for lubrication and recommended quantity. In table 2 please see possible radial loads and axial loads on the gearbox.

I Il riduttore tipo **X94C** è fornito privo di lubrificazione con tappi di sfiato, livello e scarico olio. L'utente può immettere olio minerale mantenendo i tappi esistenti. Se immetterà olio sintetico, dovrà sostituire i tappi esistenti con altri tipo chiuso. Tab.1 per oli e quantità consigliati. Tab.2 carichi radiali e assiali applicabili al riduttore.

D Das Getriebe der Baugröße **X94C** wird ohne Schmiermittel geliefert. Es ist jedoch mit Einfüllschraube, Überdruckventil und Ablassschraube ausgerüstet. Das benötigte mineralische Öl kann über die Einfüllschraube eingefüllt werden. Sollte synthetisches Öl bevorzugt werden, so ist sind das eingebaute Überdruckventil durch eine geschlossenen Schraube zu ersetzen. In Tabelle 1 ist die Schmiermenge und das empfohlene Schmiermittel angegeben. In Tabelle 2 sind die zulässigen Radial - und Axialbelastungen des Getriebes aufgeführt.

F Le réducteur de type **X94C** est fourni sans lubrification et avec un bouchon de remplissage, de niveau et d'évacuation de l'huile. L'utilisateur peut y verser de l'huile minérale en conservant les bouchons existants. S'il y versera de l'huile synthétique, il devra substituer les bouchons existants avec d'autres bouchons de type fermé. Voir tableau 1 concernant les huiles et les quantités conseillées. Voir tableau 2 concernant les charges radiales et axiales applicables au réducteur

E El reductor tamaño **X94C** se suministra sin lubricante, provisto de tapones de respiración, nivel y descarga de aceite. El usuario puede utilizar aceite mineral, manteniendo los tapones existentes. Si prefiere utilizar aceite sintético deberá sustituir los tapones existentes por tapones ciegos. La prerreducción se suministra con tapones ciegos, lubricado de por vida con aceite sintético. Ver tabla 1, para cantidades y aceites recomendados. En la tabla 2, se encuentran las cargas radiales y axiales admitidas por el reductor.

Standard supplied	For these mounting position specify in the order or add oil Per queste posizioni specificare in fase d'ordine o aggiungere olio					
B3	B6	B7	B8	V5	V6	V8
4.60 LT	3.90 LT	4.60 LT	5.30 LT	7.90 LT	5.60 LT	Ask
AGIP Blasias 460						

For all details on lubrication and plugs check our website [tab. 1](#)
Per maggiori dettagli su lubrificazione e tappi olio vedi il nostro sito web

RADIAL AND AXIAL LOADS

Output shaft
Albero di uscita

$F_{eq} = FR \cdot \frac{178.5}{X+228.5}$

n_2	FA	FR	n_2	FA	FR	n_2	FA	FR
300	1800	9000	140	2700	13500	70	3020	15100
250	2400	12000	120	2800	14000	40	3200	16000
200	2600	13000	85	2900	14500	15	3500	17500

Input shaft
Albero di entrata

n_1	FA	FR
1400	450	2250
900	500	2500
500	600	3000

tab. 2

PX94CC... Basic Gearbox
Riduttore base

Gearbox weight
peso riduttore **68.5 kg**

M. flanges	Kit code	øF	A
71B5	KC023.4.041	160	336
80/90B5	KC023.4.042	200	338
100/112B5	KC023.4.043	250	347
132B5	KC50.4.043	300	365
80B14	KC085.4.046	120	338
90B14	KC085.4.045	140	338
100/112B14	KC085.4.047	160	347
132B14	KC50.4.041	200	365

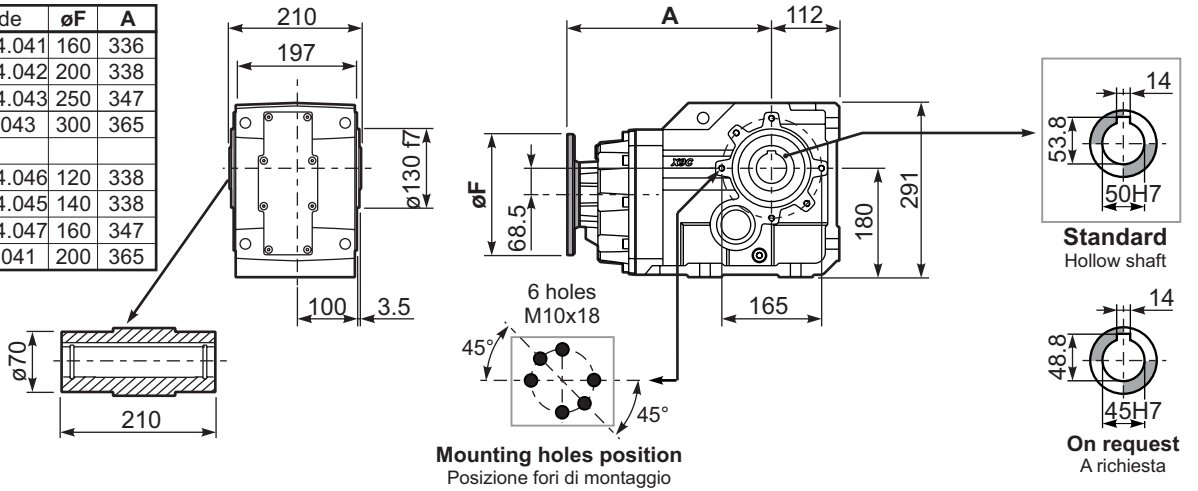

Mounting holes position
Posizione fori di montaggio

PX94C...FB.. Feet
Piedini

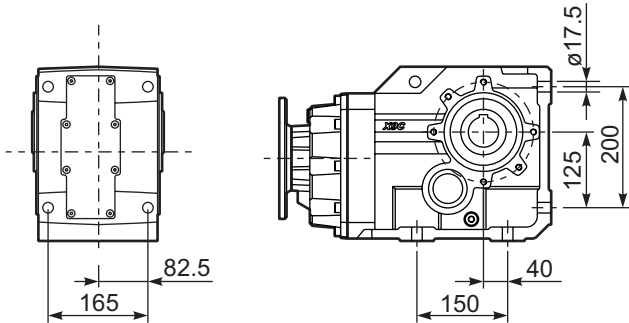

PX94C...-FC.. Output flange
Flangia uscita

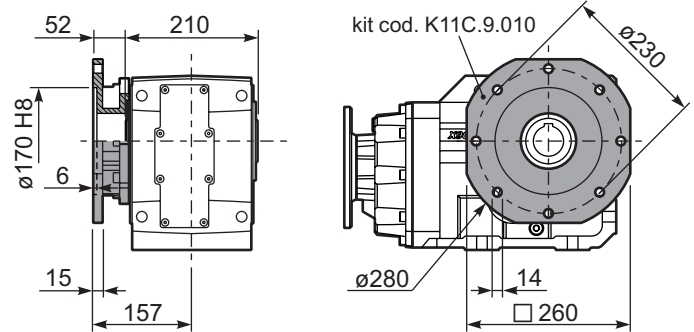

PX94C...-FL.. Output flange
Flangia uscita

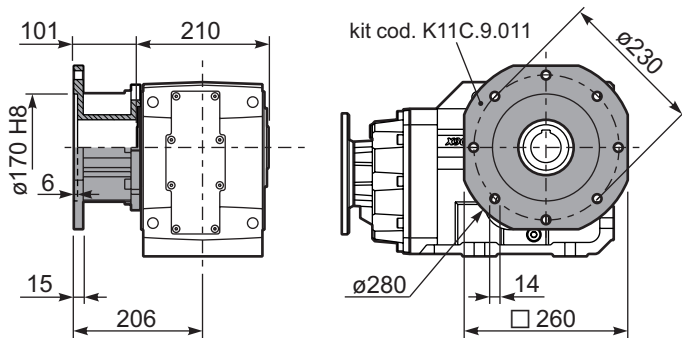

PX94C...BR.. Reaction Arm
Braccio di reazione

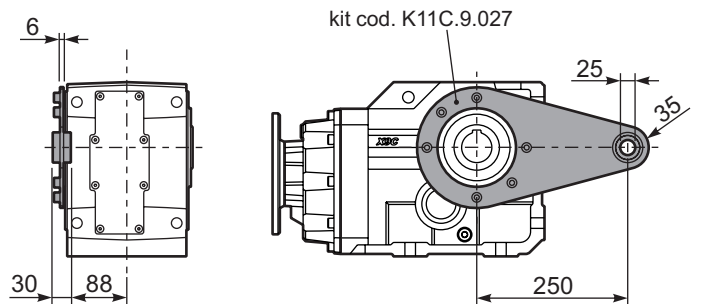

RX94C... Input shaft
Albero in entrata

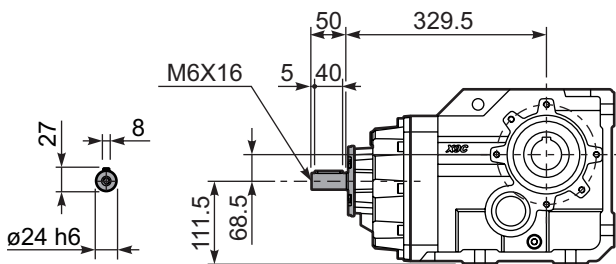

PX94CA... Single shaft
Albero lento semplice

PX94CB... Double shaft
Albero lento bisp.

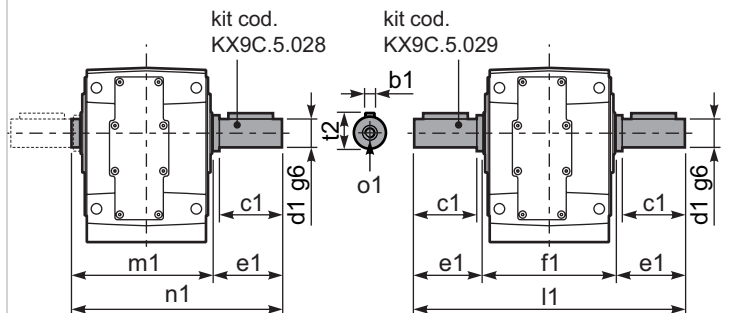

	b1	c1	d1	e1	f1	l1	m1	n1	t2	o1
Standard	14	100	50	105	210	420	218	323	53.5	M16
-	-	-	-	-	-	-	-	-	-	-

Stainless Steel Gears I30 ÷ I11

STANDARD FEATURES

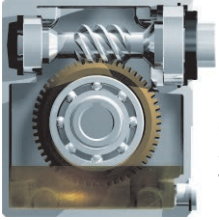

Special housing designed to keep adequate lubrication with low Oil q.ty to avoid internal pressures.

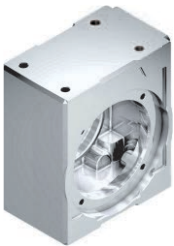

Full Stainless Steel Housing.



Output seals (FPM-fkm) with external dust protection lips.

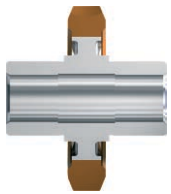

Stainless Steel Hollow shaft.

O-rings on all closing covers.



Life lubricated fully synthetic oil

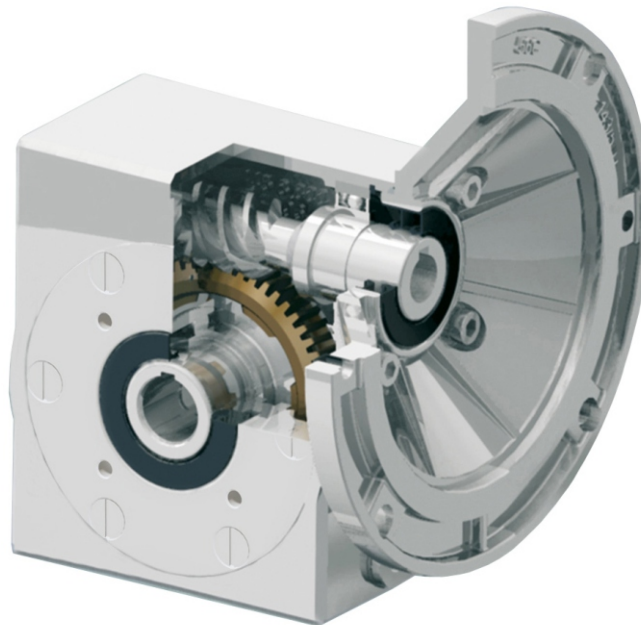

Optional interchangeable right or left hand output shafts available.

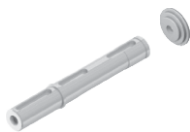

100 % Factory pressure leak test.



OPTIONS

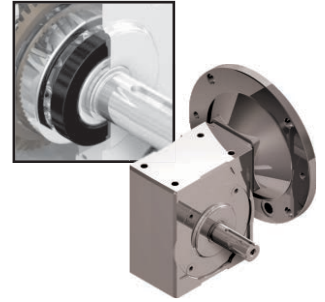

Protective seals cup to stand high pressure cleaning for hollow or extended shaft version.

Second Bearing

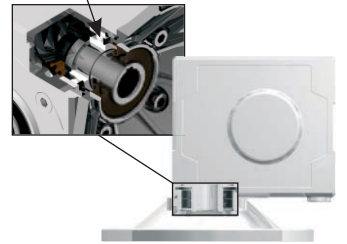

Standard second bearing on motor flange side and two oil seals with vertical motor position.

TORQUE ARM



Specific type datasheet on page...

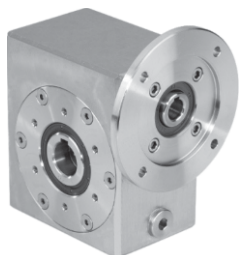

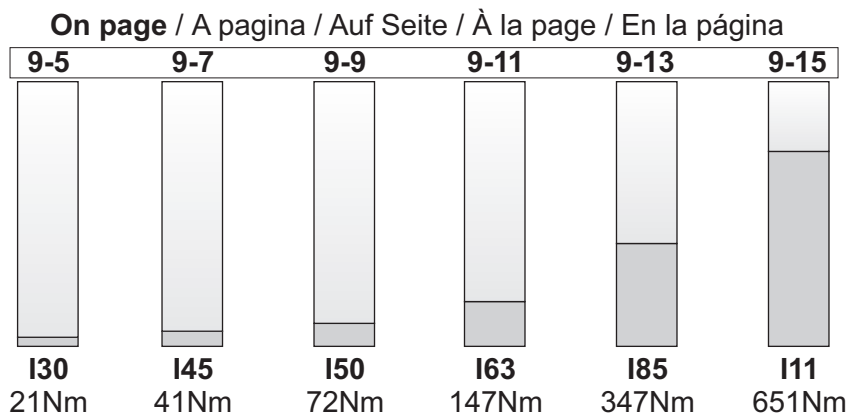

Types / Tipi /
Tipen / Types /
Tipos →

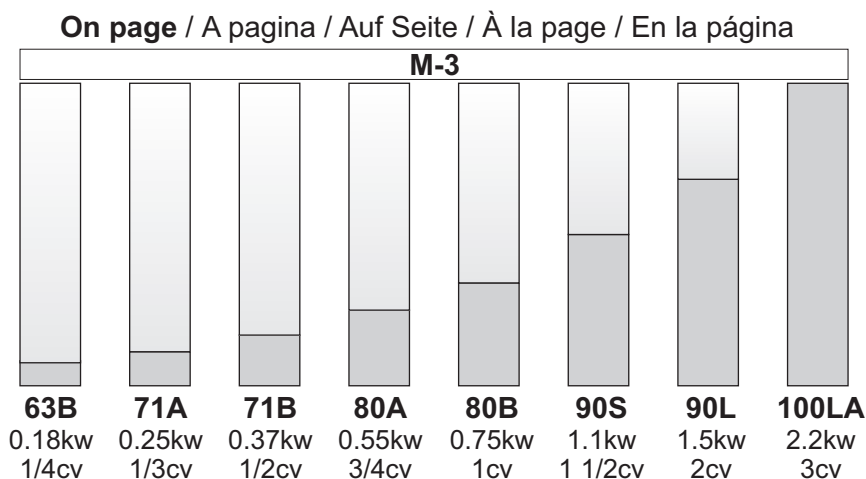

Types / Tipi /
Tipen / Types /
Tipos →

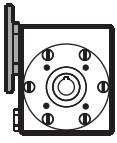

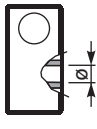
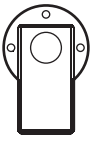
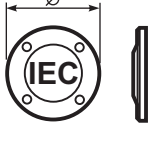
Type - Tipo - Typ Type - Tipo	Size - Grandezza Grösse - Taille Tamaño	Mounting - Montaggio Montage - Fixation Tipo de montaje	Ratio - Rapporto Untersetzung Reduction - Relación	Hub - Mozzo corona Hohlwelle - Arbre creux Nucleo corona	Output shaft Albero lento Abtriebswelle Arbre de sortie Eje solida	Motor size - Grandezza motore Motor Grösse Grandeur moteur - Tamaño motor
P	I45	UN	10	I	S	-Q
	I30 I45 I50 I63 I85 I11		<p>See technical data table</p> <p>Vedi tabella dati tecnici.</p> <p>Technisches Datenblatt beachten</p> <p>Voir Tableau données techniques</p> <p>Ver tabla datos técnicos</p>			
M		UN		I STANDARD	Ø	I30 -O -P -W 56B14 (ø80) 63B14 (ø90) 56C (ø6.5")
B		FL		I30 ⇨ ø14 I45 ⇨ ø18 I50 ⇨ ø25 I63 ⇨ ø25 I85 ⇨ ø35 I11 ⇨ ø42	S	I45 -P -Q -W 63B14 (ø90) 71B14 (ø105) 56C (ø6.5")
R		BR		I50 ⇨ ø0.750" I50 ⇨ ø1.000" I63 ⇨ ø1.125" I85 ⇨ ø1.500" I11 ⇨ ø2.000"	Z INCH	I50 -P -Q -R -W 63B14 (ø90) 71B14 (ø105) 80B14 (ø120) 56C (ø6.5")
				Full stainless steel Torque arm		I63 -Q -R -T -W -X 71B14 (ø105) 80B14 (ø120) 90B14 (ø140) 56C (ø6.5") 143/5TC (ø6.5")
					I85 -D -E -U -W -X -Y 80B5 (ø200) 90B5 (ø200) 100-112B14 (ø160) 56C (ø6.5") 143/5TC (ø6.5") 182/4TC (ø8.88") 213/5TC (ø8.88")	
					I11 -D -E -U -X -Y AA 80B5 (ø200) 90B5 (ø200) 100-112B14 (ø160) 143/5TC (ø6.5") 182/4TC (ø8.88") 213/5TC (ø8.88")	

On request

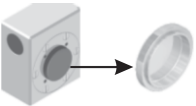
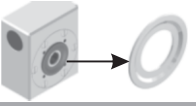
A	Protective seals cup CLOSE TYPE	
B	Protective seals cup OPEN TYPE	
C	Food lube	
D	Nema input flanges	

-M
without flange
Senza flangia

-O
Type R
Tipo R



On request we can deliver our products according to the ATEX
 A richiesta possiamo fornire i nostri prodotti secondo le normative ATEX
 Auf Anfrage können wir unsere Produkte den Richtlinien ATEX entsprechend liefern
 Sur demande nos produits peuvent se conformer à la réglementation ATEX
 A pedido, se pueden enviar nuestros productos de acuerdo con las normas ATEX.

POTENZA RICHIESTA / REQUIRED POWER / ERFORDERLICHE LEISTUNG / PUISSANCE NECESSAIRE / POTENCIA NECESARIA

Lifting / sollevamento / hubantriebe / levage / elevación

$$P \text{ [KW]} = \frac{M \text{ [Kg]} \cdot g \text{ [9.81]} \cdot v \text{ [m / s]}}{1000}$$

Rotation / rotazione / drehung / rotation / rotacion

$$P \text{ [KW]} = \frac{M \text{ [Nm]} \cdot n \text{ [rpm]}}{9550}$$

Linear movement / traslazione / linearbewegung / translation / translacion

$$P \text{ [KW]} = \frac{F \text{ [N]} \cdot v \text{ [m / s]}}{1000}$$

TORQUE / COPPIA / DREHMOMENT / COUPLE / PAR

$$M \text{ [Nm]} = \frac{9550 \cdot P \text{ [KW]}}{n \text{ [rpm]}}$$

$$M \text{ [lb in]} = \frac{63030 \cdot P \text{ [HP]}}{n \text{ [rpm]}}$$

RADIAL LOADS / CARICHI RADIALI / RADIALE - UND AXIALLASTEN / CHARGES RADIALES / CARGA RADIAL Y AXIAL

- Radial load generated by external transmissions keyed onto input and/or output shafts.
- Forza radiale generata da organi di trasmissione calettati sugli alberi di ingresso e/o uscita.
- Belastungen der Antriebs- bzw. Abtriebswellen durch von aussen eingebrachte Radiallasten.
- Charge radiale générée par la transmissions calés sur les entrées et / ou des arbres de sortie
- Cargas radiales, generada por transmisiones externas, aplicadas sobre los ejes de entrada y/o salida

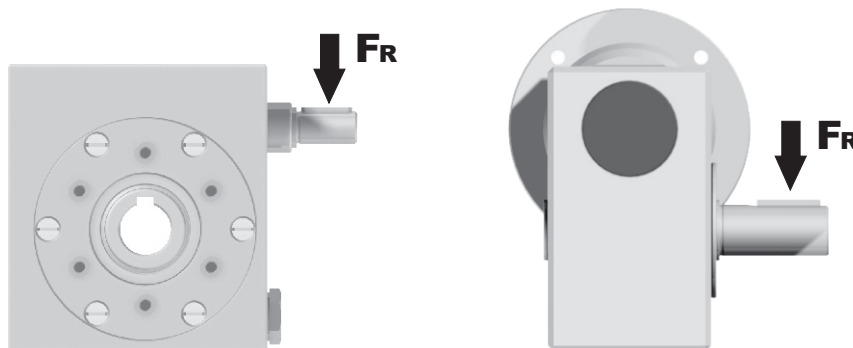

$$F_R \text{ [N]} = \frac{M \text{ [Nm]} \cdot 2000}{d \text{ [mm]}} \cdot f_k$$

$$F_R \text{ [N]} = \frac{M \text{ [lb in]} \cdot 8.9}{d \text{ [in]}} \cdot f_k$$

M	Momento torcente / Output torque / Abtriebsdrehmoment / Couple / Par torsion
d	Diametro primitivo / Diam. of driving element / Durchmesser der Abtriebseinheit / Diamètre primitif / Diámetro primitivo
f_k	Coefficiente di trasformazione / Factor / Faktor / Coefficient de transmission / Coeficiente de transmisión 1.15 Ingranaggi / Gearwheels / Zahnrad / Engrenage / Engranaje 1.25 Catena / Chain sprochets / Antriebskette / Chaîne / Cadena 1.75 Cinghia Trapezoidale / Narrow v-belt pulley / Keilriemen / Courroie trap. / Correa trapezoidal 2.50 Cinghia piatta / Flat-belt pulley / Flachzahnriem. / Courroie crantée / Correa plana

- If your application requires higher radial loads, contact our technical office. Higher load may be possible.
- Nel caso la vostra applicazione richieda carichi radiali superiori consultare il nostro ufficio tecnico, valori maggiori possono essere accettati.
- Wenn Ihre Anwendung höhere Radialbelastungen erfordert, so wenden Sie sich bitte an unser technischen Büro.
- Si votre application demande des charges radiales supérieures, s'adresser à notre bureau technique.
- En el caso en que una aplicación exija una carga radial superior a la especificada en el catálogo, consultar a nuestra oficinas técnica.

How to select a gearbox / Come selezionare un riduttore / Wie wählt man ein Getriebe
Comment sélectionner un réducteur / Cómo seleccionar un reductor

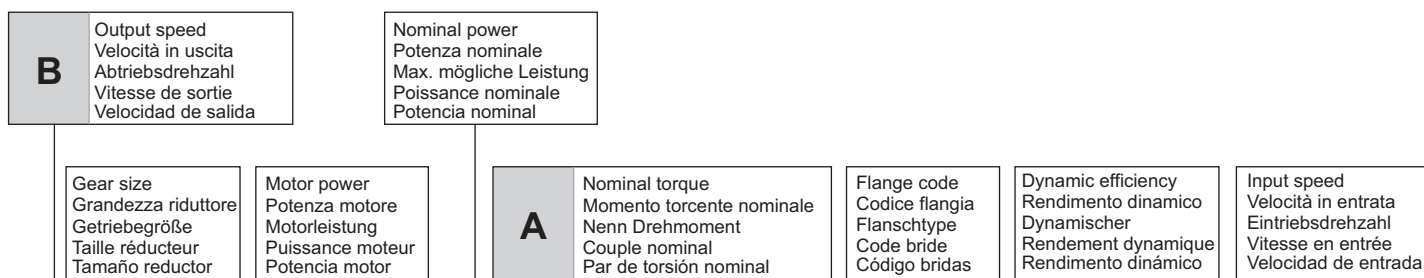

145 Stainlesssteel - Gear **41Nm** Rating - Stainlesssteel WORM GEARBOXES

QUICK SELECTION / Selezione veloce input speed (n₁) = 1400 min⁻¹

Output Speed n ₂ [min ⁻¹]	Ratio i	Motor power P _{1M} [kW]	Output torque M _{2M} [Nm]	Service factor f.s.	Nominal power P _{1R} [kW]	Nominal torque M _{2R} [Nm]	B5 motor flanges not available		Available B14 motor flanges		Dynamic efficiency RD	Tooth Module [mm]	Ratios code
							-	-	P	Q			
200	7	0.37	14	2.2	0.80	30	-	-	63	71	80	2.2	01
140	10	0.37	20	1.5	0.57	30	-	-	B-C	B-C	79	2.2	02
100	14	0.37	27	1.1	0.41	30	-	-	B-C	B-C	77	2.4	03



fs

Type of load and starts per hour Tipo di carico e avviamenti per ora		Oper. hours per day Ore di funz. giorn.		
		<2 h	2 - 8 h	8 - 16 h
Continuous or intermittent appl. with start / hour Applicazione cont. o interm. con n.ro operazioni/ora	Uniform / Uniforme	0.9	1	1.25
	Moderate / Moderato	1	1.25	1.5
	Heavy / Forte	1.25	1.5	1.75
Intermittent application with start / hour Applicazione intermittente con n.ro operazioni/ora	Uniform / Uniforme	1.25	1.5	1.75
	Moderate / Moderato	1.5	1.75	2
	Heavy / Forte	1.75	2	2.25

D Motor flange available
Flange disponibili
Erhältliche Motorflansche
Brides disponibles
Bridas disponibles

B) Mounting with reduction ring
Montaggio con boccolla di riduzione
Reduzierhülsen
Montage avec douille de réduction
Montaje con casquillo de reducción

C) Motor flangeholes position/terminal box position
Posizione fori flangia/basetta motore
Bohrungsposition am Motorflansch/-socket
Position trous bride/barrette à bornes moteur
Posición agujeros brida / base motor

B) Available without reduction bushes
Disponibile anche senza boccolla
Auch ohne Reduzierbuchse verfügbar
Disponible aussi sans douille de réduction
Disponible también sin casquillo

A	Select required torque (according to service factor)	Seleziona la coppia desiderata (comprensiva del fattore di servizio)	Max. Drehmoment in Bezug zum Betriebsfaktor	Sélectionner le couple souhaité (comprenant le facteur de service)	Seleccionar el par deseado (incluyendo el factor de servicio)
B	Select output speed	Seleziona la velocità in uscita	Ausgewählte Abtriebsdrehzahl	Sélectionner la vitesse de sortie	Seleccionar la velocidad de salida
C	On the same line of selected geared motor, you can find the gear ratio	Sulla riga corrispondente alla motorizzazione prescelta si può rilevare il rapporto di riduzione	Auf der gleichen Linie wie die ausgewählte Motorleistung steht auch die Getriebeuntersetzung	Sur la ligne correspondante à la motorisation pré-choisie on peut relever le rapport de réduction	En la línea correspondiente al motor preseleccionado es posible encontrar la relación de reducción
D	Select motor flange available (if requested)	Scegli la flangia disponibile (se richiesta)	Erhältliche Motorflansche (auf Anfrage)	Choisir la bride disponible (si elle est demandée)	Seleccionar la brida disponible (sobre pedido)



QUICK SELECTION / Selezione veloce

input speed (n_1) = 1400 min⁻¹

Output Speed n_2 [min ⁻¹]	Ratio i	Motor power P_{1M} [kW]	Output torque M_{2M} [Nm]	Service factor f.s.	Nominal power P_{1R} [kW]	Nominal torque M_{2R} [Nm]	B5 motor flanges not available		Available B14 motor flanges		Dynamic efficiency RD	Tooth Module [mm]	Ratios code
							-	-	O	P			
280	5	0.18	5	3.3	0.60	17	-	-	56	63	82	1.26	09
200	7	0.18	7	2.4	0.44	17	-	-	B-C		80	1.44	01
140	10	0.18	10	1.8	0.32	17	-	-	B-C		78	1.44	02
93	15	0.18	13	1.4	0.25	19	-	-	B-C		73	1.44	03
70	20	0.18	17	1.1	0.20	19	-	-	B-C		70	1.09	04
47	30	0.12	15	1.4	0.17	21	-	-	B-C		62	1.44	05
35	40	0.12	19	1.1	0.13	20	-	-	B-C		57	1.09	06
23	61	0.09	19	1.1	0.10	20	-	-	B-C		50	0.72	07
17.5	80	0.09	16	1.0	0.06	16	-	-	B-C		48	0.56	08

* The nominal power should be reduced if the ambient temperature is $\geq 30^\circ\text{C}$, or when a cooler gearbox is required.

* Diminuire la potenza nominale in caso di temperatura ambiente $\geq 30^\circ\text{C}$ o se è richiesta una bassa temperatura di utilizzo del riduttore.

A Motor Flanges Available
Flange Motore Disponibili

B Supplied with Reduction Bushing
Fornito con Bussola di Riduzione

B Available on Request without reduction bushing
Disponibile a Richiesta senza Bussola di Riduzione

C Motor Flange Holes Position
Posizione Fori Flangia Motore

EN Unit I30 is supplied with synthetic oil, providing "long life" lubrication. For mounting position V5-V6 please contact us. See table 1 for lubrication and recommended quantity. In table 2 please see possible radial loads and axial loads on the gearbox.

I Il riduttore tipo I30 viene fornito lubrificato a vita con olio sintetico. Per posizioni V5-V6 contattare il ns. servizio tecnico. Vedi tab.1 per oli e quantità consigliati. In tab.2 sono presenti i carichi radiali e assiali applicabili al riduttore.

D Für die Lebensdauerschmierung ist das Getriebe der Größe I30 mit synthetischem Öl befüllt. Bei Einbaulage V5 oder V6 bitten wir um Rücksprache. In Tabelle 1 ist die Schmiermenge und das empfohlene Schmiermittel angegeben. In Tabelle 2 sind die zulässigen Radial- und Axialbelastungen des Getriebes aufgeführt.

F Le réducteur de type I30 est fourni lubrifié à vie avec de l'huile synthétique. Concernant les positions V5.V6, contactez notre service d'assistance technique. Voir tableau 1 concernant les huiles et les quantités conseillées. Les charges radiales et axiales applicables au réducteur sont précisées dans le tableau 2.

E El reductor tamaño I30 se suministra, lubricado de por vida con aceite sintético. Para las posiciones V5 y V6 contactar con nuestro servicio técnico. Ver tabla 1, para cantidades y aceites recomendados. En la tabla 2, se encuentran las cargas radiales y axiales admitidas por el reductor.

LUBRICATION I30 Oil Quantity 0.07 Lt.

AGIP Telium VSF 320

SHELL Omala S4 WE 320

For all details on lubrication and plugs check our website

tab. 1

Per maggiori dettagli su lubrificazione e tappi olio vedi il nostro sito web

RADIAL AND AXIAL LOADS

Output shaft

Albero di uscita

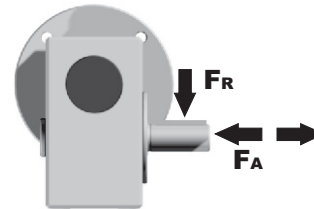

n_2 [min ⁻¹]	FA [N]	FR [N]
200	120	600
150	140	700
100	160	800
75	180	900
50	200	1000
25	250	1250
15	280	1400

Input shaft

albero in entrata

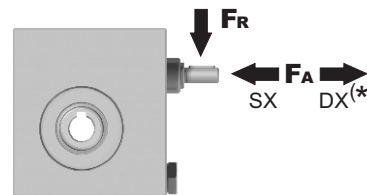

n_1 [min ⁻¹]	FA [N]	FR [N]
1400	20	100

*Strong axial loads in the DX direction are not allowed.
Non sono consentiti forti carichi assiali con direzione DX

tab. 2

Gearbox weight peso riduttore **2.5 kg**

PI30UN... Basic wormbox
Riduttore base

M. flanges	Kit code	øF	A
56B14	KI30.4.046	80	61.5
63B14	KI30.4.045	90	62.5

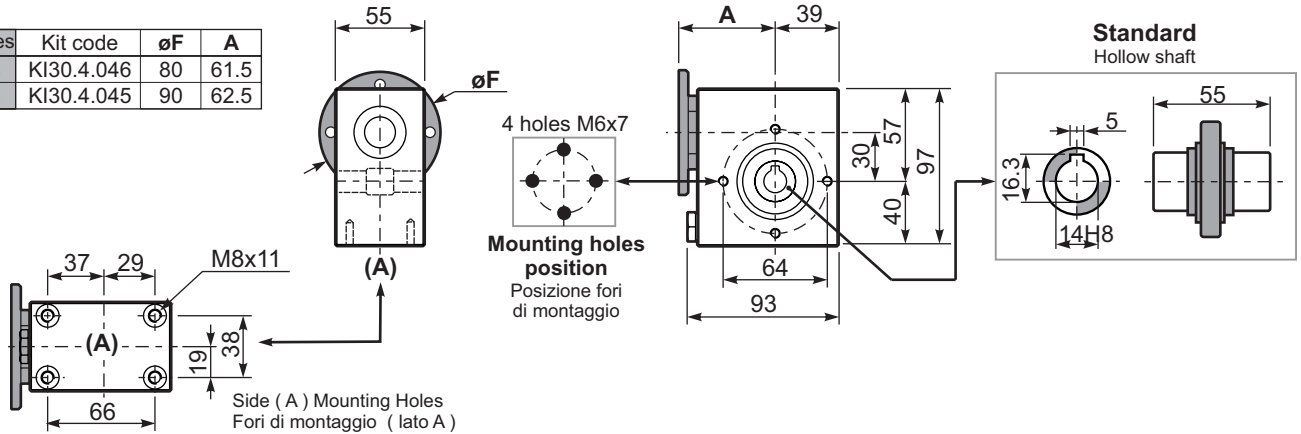

BI30UN... Modular base
Base modulare

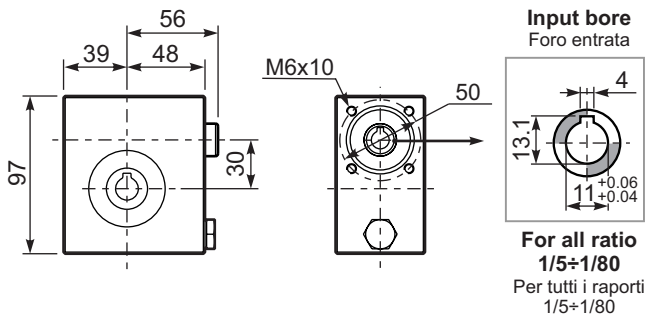

PI30FL... Output flange
Flangia uscita

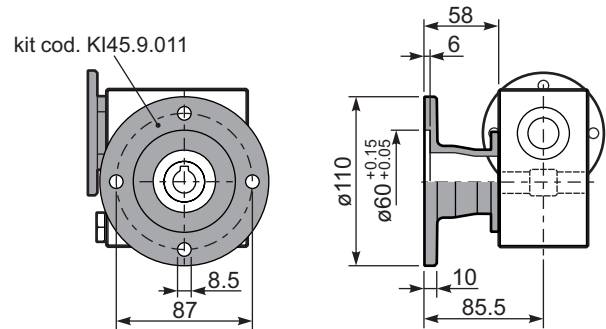

RI30UN... Input shaft
Albero in entrata

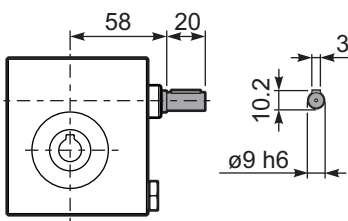

PI30BR... Reaction arm
Braccio di reazione

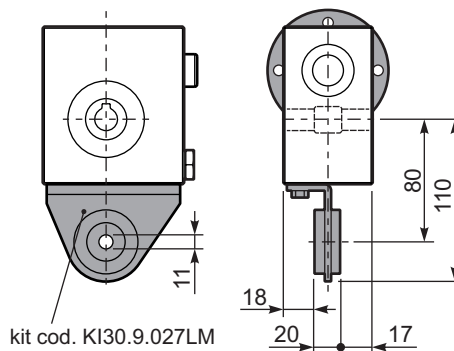

PI30.....S... Single Shaft
Albero lento semplice

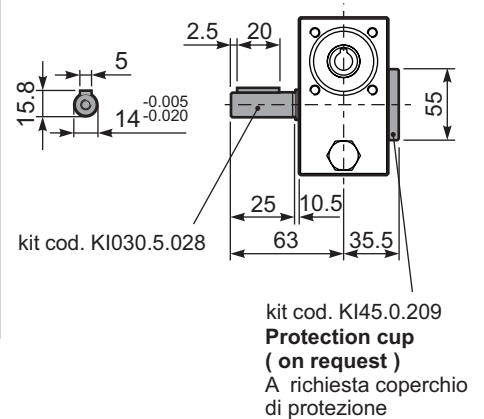



QUICK SELECTION / Selezione veloce

input speed (n_1) = 1400 min⁻¹

Output Speed n_2 [min ⁻¹]	Ratio i	Motor power P_{1M} [kW]	Output torque M_{2M} [Nm]	Service factor f.s.	Nominal power P_{1R} [kW]	Nominal torque M_{2R} [Nm]	B5 motor flanges not available		Available B14 motor flanges		Dynamic efficiency	Tooth Module [mm]	Ratios code
							-	-	P	Q			
200	7	0.37	14	2.2	0.80	30	-	-	63	71	RD	2.2	01
140	10	0.37	20	1.5	0.57	30	-	-	B-C		79	2.2	02
100	14	0.37	27	1.1	0.41	30	-	-	B-C		77	2.4	03
67	21	0.37	36	1.2	0.43	41	-	-	B-C		67	1.6	04
50	28	0.25	31	1.3	0.33	41	-	-	B-C		65	2.5	05
38	37	0.25	40	1.0	0.26	41	-	-	B-C		63	1.8	06
30	46	0.25	46	0.9	0.22	41	-	-	B-C		59	1.5	07
23	60	0.18	41	1.0	0.18	41	-	-	B-C		56	1.2	08
20	70	0.12	31	1.0	0.12	30	-	-	B-C		54	1.0	09
13.7	102	0.09	31	1.0	0.09	29	-	-	B-C		49	0.72	10

* The nominal power should be reduced if the ambient temperature is $\geq 30^\circ\text{C}$, or when a cooler gearbox is required.

* Diminuire la potenza nominale in caso di temperatura ambiente $\geq 30^\circ\text{C}$ o se è richiesta una bassa temperatura di utilizzo del riduttore.

A) Motor Flanges Available
Flange Motore Disponibili

B) Supplied with Reduction Bushing
Fornito con Bussola di Riduzione

B) Available on Request without reduction bushing
Disponibile a Richiesta senza Bussola di Riduzione

C) Motor Flange Holes Position
Posizione Fori Flangia Motore

EN Unit I45 is supplied with synthetic oil, providing "long life" lubrication. For mounting position V5-V6 please contact us. See table 1 for lubrication and recommended quantity. In table 2 please see possible radial loads and axial loads on the gearbox.

I Il riduttore tipo I45 viene fornito lubrificato a vita con olio sintetico. Per posizioni V5-V6 contattare il ns. servizio tecnico. Vedi tab.1 per oli e quantità consigliati. In tab.2 sono presenti i carichi radiali e assiali applicabili al riduttore.

D Für die Lebensdauerschmierung ist das Getriebe der Größe I45 mit synthetischem Öl befüllt. Bei Einbaulage V5 oder V6 bitten wir um Rücksprache. In Tabelle 1 ist die Schmiermenge und das empfohlene Schmiermittel angegeben. In Tabelle 2 sind die zulässigen Radial- und Axialbelastungen des Getriebes aufgeführt.

F Le réducteur de type I45 est fourni lubrifié à vie avec de l'huile synthétique. Concernant les positions V5.V6, contactez notre service d'assistance technique. Voir tableau 1 concernant les huiles et les quantités conseillées. Les charges radiales et axiales applicables au réducteur sont précisées dans le tableau 2.

E El reductor tamaño I45 se suministra, lubricado de por vida con aceite sintético. Para las posiciones V5 y V6 contactar con nuestro servicio técnico. Ver tabla 1, para cantidades y aceites recomendados. En la tabla 2, se encuentran las cargas radiales y axiales admitidas por el reductor.

LUBRICATION I45 Oil Quantity 0.24 Lt.

AGIP Telium VSF 320

SHELL Omala S4 WE 320

For all details on lubrication and plugs check our website

Per maggiori dettagli su lubrificazione e tappi olio vedi il nostro sito web

tab. 1

RADIAL AND AXIAL LOADS

Output shaft

Albero di uscita

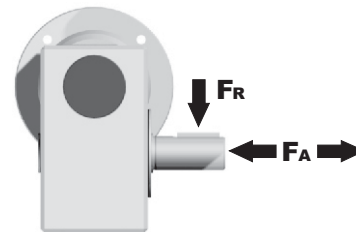

n_2 [min ⁻¹]	FA [N]	FR [N]
200	180	900
150	200	1000
100	220	1100
75	240	1200
50	260	1400
25	300	1800
15	400	2000

Input shaft

albero in entrata

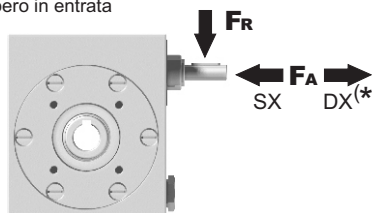

n_1 [min ⁻¹]	FA [N]	FR [N]
1400	42	210

*Strong axial loads in the DX direction are not allowed.
Non sono consentiti forti carichi assiali con direzione DX

tab. 2

Gearbox weight
peso riduttore **5.0 kg**

PI45**UN**... Basic wormbox
Riduttore base

M. flanges	Kit code	øF	A
63B14	KI50.4.047	90	73.5
71B14	KI50.4.045	105	71

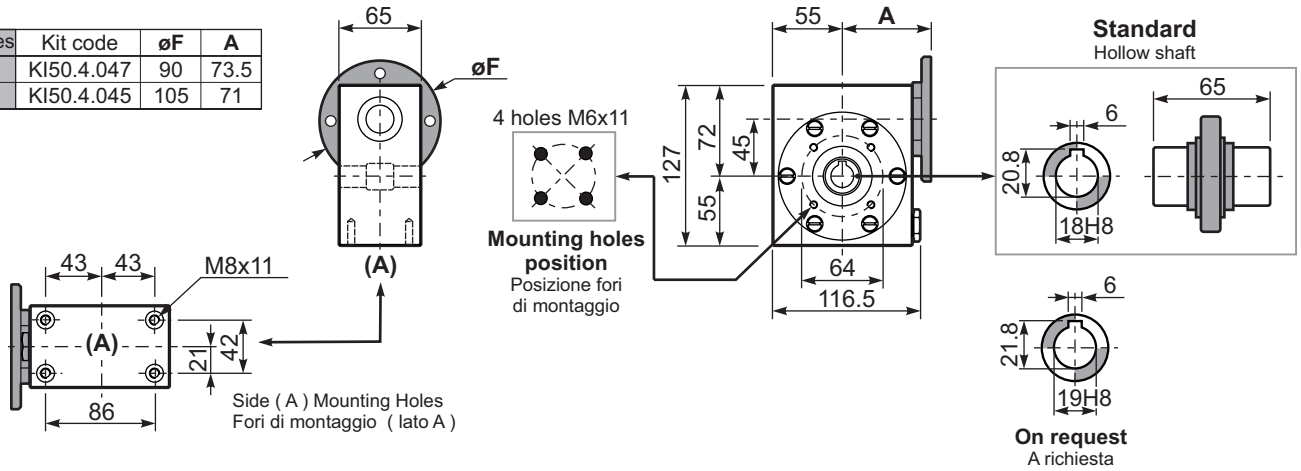

BI45UN... Modular base
Base modulare

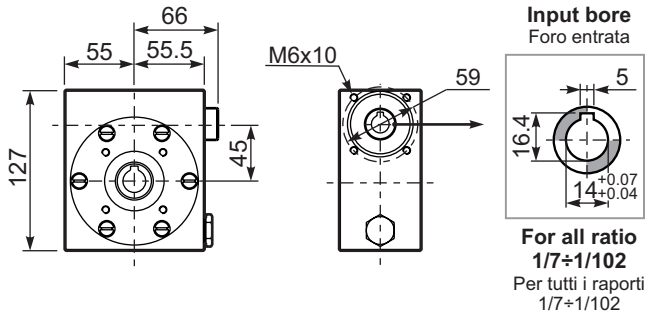

PI45FL... Output flange
Flangia uscita

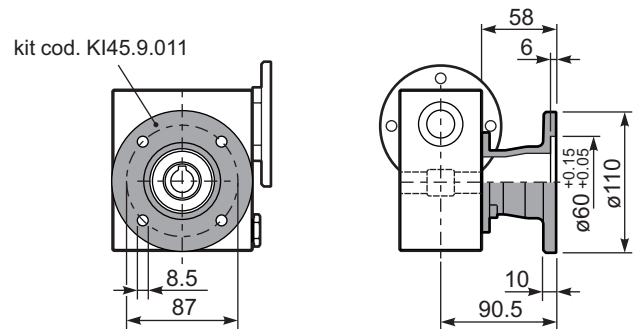

RI45UN... Input shaft
Albero in entrata

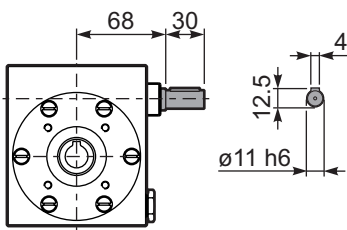

PI45BR... Reaction arm
Braccio di reazione

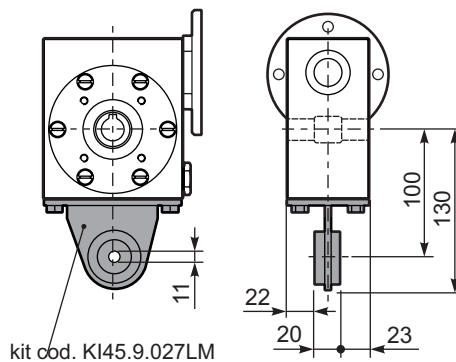

PI45....S... Single Shaft
Albero lento semplice

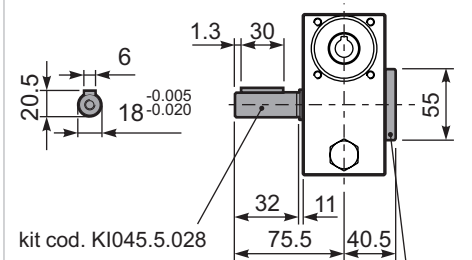

kit cod. KI45.0.209
Protection cup (on request)
A richiesta coperchio di protezione



QUICK SELECTION / Selezione veloce

input speed (n_1) = 1400 min⁻¹

Output Speed n_2 [min ⁻¹]	Ratio i	Motor power P_{1M} [kW]	Output torque M_{2M} [Nm]	Service factor f.s.	Nominal power P_{1R} [kW]	Nominal torque M_{2R} [Nm]	B5 motor flanges not available		Available B14 motor flanges			Dynamic efficiency RD	Tooth Module [mm]	Ratios code
							-	-	P	Q	R			
200	7	0.75	29	1.9	1.5	57	-	-	B-C	B		82	2.5	01
140	10	0.75	41	1.5	1.1	62	-	-	B-C	B		80	2.4	02
100	14	0.75	57	1.2	0.90	68	-	-	B-C	B		79	2.6	03
78	18	0.55	51	1.2	0.67	62	-	-	B-C	B		75	2.0	04
54	26	0.55	67	1.0	0.54	66	-	-	B-C	B		69	2.7	05
47	30	0.55	79	0.9	0.50	72	-	-	B-C	B		70	2.5	12
39	36	0.37	63	1.2	0.43	72	-	-	B-C	B		69	2.1	06
33	43	0.37	72	1.0	0.35	68	-	-	B-C	B		66	1.8	07
23	60	0.25	59	1.0	0.26	62	-	-	B-C	B		58	1.3	08
21	68	0.25	66	0.9	0.22	58	-	-	B-C	B		57	1.2	09
17.5	80	0.18	53	1.1	0.19	57	-	-	B-C	B		54	1.0	10
14	100	0.12	41	1.3	0.15	51	-	-	B-C	B		50	0.8	11

* The nominal power should be reduced if the ambient temperature is $\geq 30^\circ\text{C}$, or when a cooler gearbox is required.

* Diminuire la potenza nominale in caso di temperatura ambiente $\geq 30^\circ\text{C}$ o se è richiesta una bassa temperatura di utilizzo del riduttore.

A Motor Flanges Available
Flange Motore Disponibili

B Supplied with Reduction Bushing
Fornito con Bussola di Riduzione

B Available on Request without reduction bushing
Disponibile a Richiesta senza Bussola di Riduzione

C Motor Flange Holes Position
Posizione Fori Flangia Motore

EN Unit 150 is supplied with synthetic oil, providing "long life" lubrication. For mounting position V5-V6 please contact us.
See table 1 for lubrication and recommended quantity. In table 2 please see possible radial loads and axial loads on the gearbox.

I Il riduttore tipo 150 viene fornito lubrificato a vita con olio sintetico. Per posizioni V5-V6 contattare il ns. servizio tecnico.
Vedi tab.1 per oli e quantità consigliati. In tab.2 sono presenti i carichi radiali e assiali applicabili al riduttore.

D Für die Lebensdauerschmierung ist das Getriebe der Größe 150 mit synthetischem Öl befüllt. Bei Einbaulage V5 oder V6 bitten wir um Rücksprache. In Tabelle 1 ist die Schmiermenge und das empfohlene Schmiermittel angegeben. In Tabelle 2 sind die zulässigen Radial- und Axialbelastungen des Getriebes aufgeführt.

F Le réducteur de type 150 est fourni lubrifié à vie avec de l'huile synthétique. Concernant les positions V5.V6, contactez notre service d'assistance technique. Voir tableau 1 concernant les huiles et les quantités conseillées. Les charges radiales et axiales applicables au réducteur sont précisées dans le tableau 2.

E El reductor tamaño 150 se suministra, lubricado de por vida con aceite sintético. Para las posiciones V5 y V6 contactar con nuestro servicio técnico. Ver tabla 1, para cantidades y aceites recomendados. En la tabla 2, se encuentran las cargas radiales y axiales admitidas por el reductor.

LUBRICATION 150 Oil Quantity 0.38 Lt

AGIP Telium VSF 320

SHELL Omala S4 WE 320

For all details on lubrication and plugs check our website **tab. 1**
Per maggiori dettagli su lubrificazione e tappi olio vedi il nostro sito web

RADIAL AND AXIAL LOADS

Output shaft

Albero di uscita

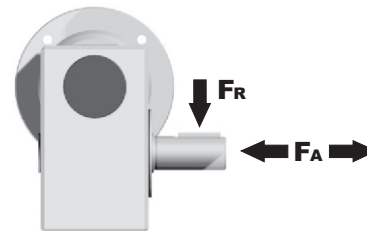

n_2 [min ⁻¹]	FA [N]	FR [N]
200	240	1200
150	280	1400
100	300	1500
75	340	1700
50	380	1900
25	480	2500
15	560	2800

Input shaft

albero in entrata

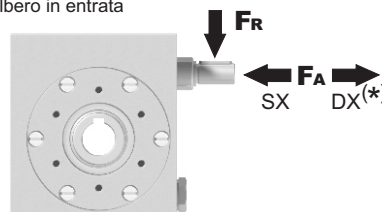

n_1 [min ⁻¹]	FA [N]	FR [N]
1400	76	380

*Strong axial loads in the DX direction are not allowed.
Non sono consentiti forti carichi assiali con direzione DX

tab. 2

Gearbox weight **7.3 kg**
peso riduttore

PI50**UN**... Basic wormbox
Riduttore base

M. flanges	Kit code	øF	A
63B14	KI50.4.047	90	78
71B14	KI50.4.045	105	78
80B14	KI50.4.046	120	76

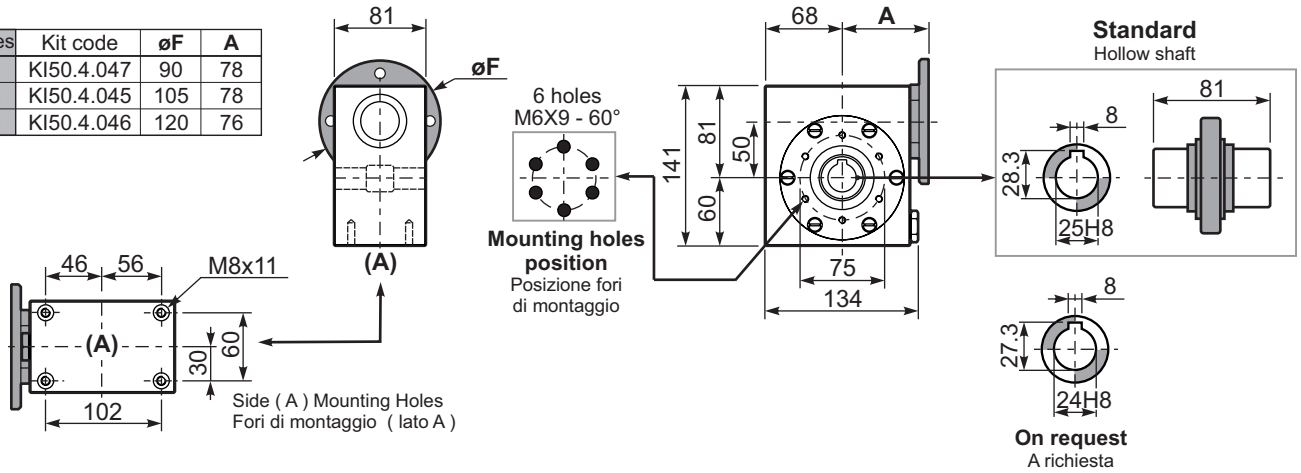

BI50UN... Modular base
Base modulare

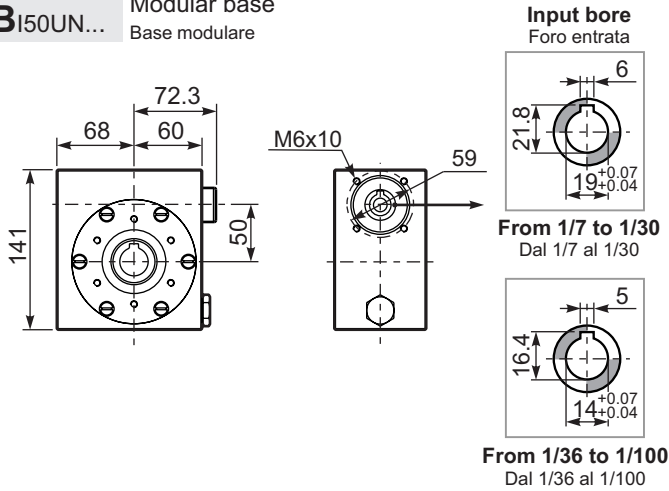

PI50FL... Output flange
Flangia uscita

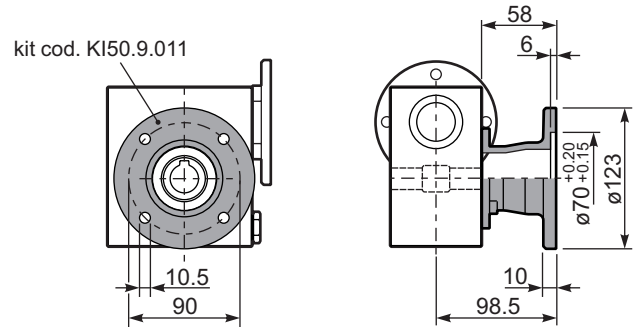

RI50UN... Input shaft
Albero in entrata

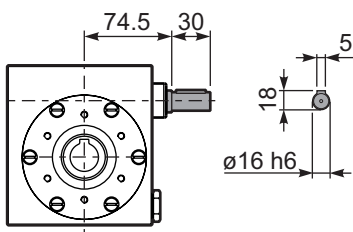

PI50BR... Reaction arm
Braccio di reazione

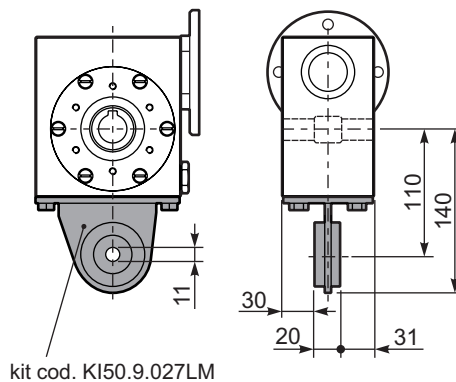

PI50.....S... Single Shaft
Albero lento semplice

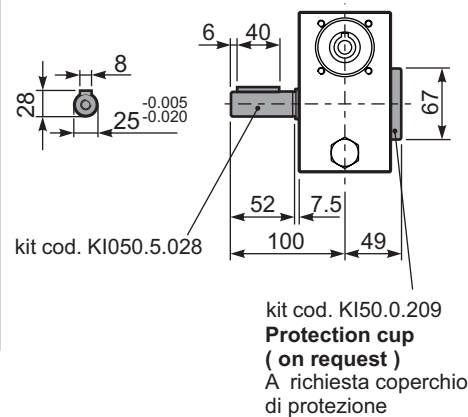



QUICK SELECTION / Selezione veloce

input speed (n_1) = 1400 min⁻¹

Output Speed n_2 [min ⁻¹]	Ratio i	Motor power P_{1M} [kW]	Output torque M_{2M} [Nm]	Service factor f.s.	Nominal power P_{1R} [kW]	Nominal torque M_{2R} [Nm]	B5 motor flanges not available		Available B14 motor flanges			Dynamic efficiency RD	Tooth Module [mm]	Ratios code
							-	-	Q	R	T			
200	7	1.8	71	1.8	3.2	125			B-C	B-C		83	3.1	01
140	10	1.8	99	1.4	2.4	134			B-C	B-C		81	3.1	02
93	15	1.5	121	1.1	1.7	138			B-C	B-C		79	3.1	03
74	19	1.1	111	1.2	1.4	138			B-C	B-C		78	2.6	04
58	24	1.1	135	1.0	1.2	142			B-C	B-C		75	2.0	05
47	30	1.1	167	0.9	0.96	146			B-C	B-C		74	3.2	06
39	36	0.75	125	1.2	0.88	147			B-C	B-C		68	2.7	07
31	45	0.55	111	1.2	0.67	135			B-C	C		66	2.1	08
23	60	0.55	140	0.9	0.51	130			B-C	C		62	1.6	12
21	67	0.55	151	0.8	0.45	124			B-C	C		60	1.5	09
17.5	80	0.37	115	1.0	0.38	119			B-C	C		57	1.3	10
14.9	94	0.37	123	1.0	0.36	119			B-C	C		52	1.1	11

* The nominal power should be reduced if the ambient temperature is $\geq 30^\circ\text{C}$, or when a cooler gearbox is required.

* Diminuire la potenza nominale in caso di temperatura ambiente $\geq 30^\circ\text{C}$ o se è richiesta una bassa temperatura di utilizzo del riduttore.

Motor Flanges Available
Flange Motore Disponibili

B) Supplied with Reduction Bushing
Fornito con Bussola di Riduzione

B) Available on Request without reduction bushing
Disponibile a Richiesta senza Bussola di Riduzione

C) Motor Flange Holes Position
Posizione Fori Flangia Motore

EN Unit I63 is supplied with synthetic oil, providing "long life" lubrication. For mounting position V5-V6 please contact us. See table 1 for lubrication and recommended quantity. In table 2 please see possible radial loads and axial loads on the gearbox.

I Il riduttore tipo I63 viene fornito lubrificato a vita con olio sintetico. Per posizioni V5-V6 contattare il ns. servizio tecnico. Vedi tab.1 per oli e quantità consigliati. In tab.2 sono presenti i carichi radiali e assiali applicabili al riduttore.

D Für die Lebensdauerschmierung ist das Getriebe der Größe I63 mit synthetischem Öl befüllt. Bei Einbaulage V5 oder V6 bitten wir um Rücksprache. In Tabelle 1 ist die Schmiermenge und das empfohlene Schmiermittel angegeben. In Tabelle 2 sind die zulässigen Radial - und Axialbelastungen des Getriebes aufgeführt.

F Le réducteur de type I63 est fourni lubrifié à vie avec de l'huile synthétique. Concernant les positions V5.V6, contactez notre service d'assistance technique. Voir tableau 1 concernant les huiles et les quantités conseillées. Les charges radiales et axiales applicables au réducteur sont précisées dans le tableau 2.

E El reductor tamaño I63 se suministra, lubricado de por vida con aceite sintético. Para las posiciones V5 y V6 contactar con nuestro servicio técnico. Ver tabla 1, para cantidades y aceites recomendados. En la tabla 2, se encuentran las cargas radiales y axiales admitidas por el reductor.

Standard	On request				
B3	B6	B7	B8	V5	V6
0.98 LT	0.69 LT	0.69 LT	0.98 LT	0.98 LT	0.98 LT
AGIP Telium VSF 320			SHELL Omala S4 WE 320		

For all details on lubrication and plugs check our website **tab. 1**
Per maggiori dettagli su lubrificazione e tappi olio vedi il nostro sito web

RADIAL AND AXIAL LOADS

Output shaft

Albero di uscita

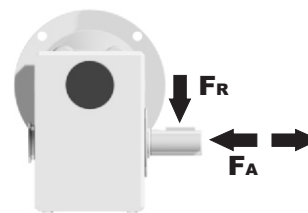

n_2	FA	FR
200	360	1800
150	400	2000
100	460	2300
75	500	2500
50	600	3000
25	700	3800
15	800	4000

Input shaft

albero in entrata

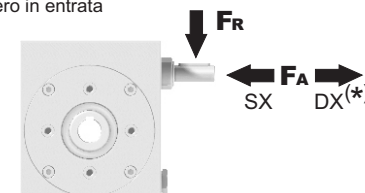

n_1 [min ⁻¹]	FA [N]	FR [N]
1400	90	450

*Strong axial loads in the DX direction are not allowed.
Non sono consentiti forti carichi assiali con direzione DX

tab. 2

Gearbox weight
peso riduttore **14.6 kg**

PI63UN... Basic wormbox
Riduttore base

M. flanges	Kit code	øF	A
71B14	KI63.4.047	105	97
80B14	KI63.4.046	120	98
90B14	KI63.4.041	140	99

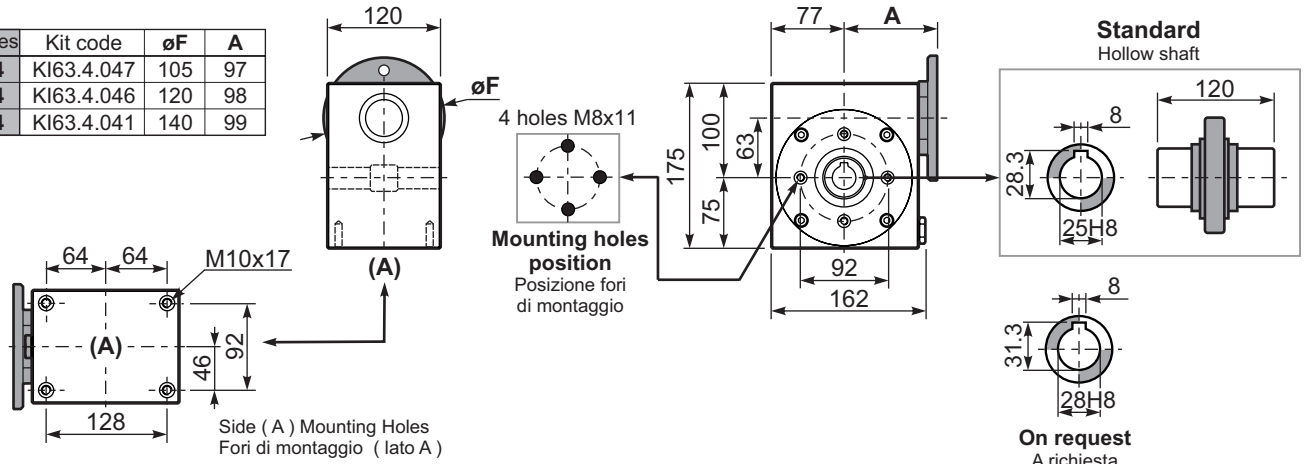

BI63UN... Modular base
Base modulare

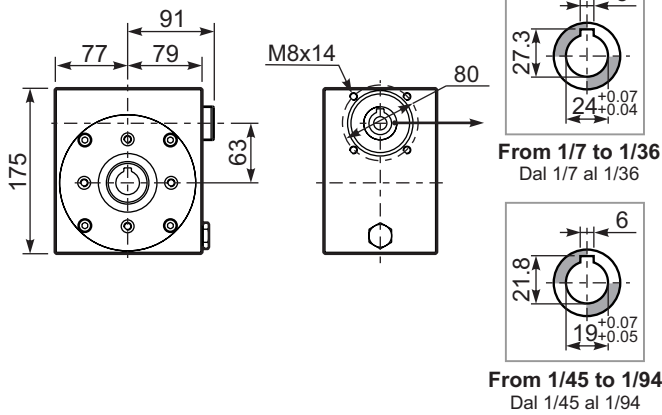

PI63FL... Output flange
Flangia uscita

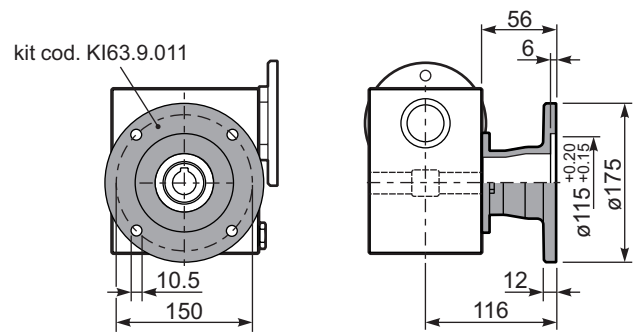

RI63UN... Input shaft
Albero in entrata

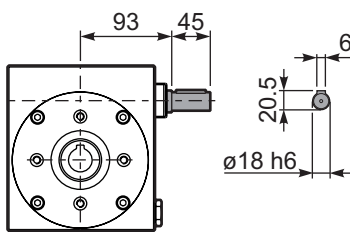

PI63BR... Reaction arm
Braccio di reazione

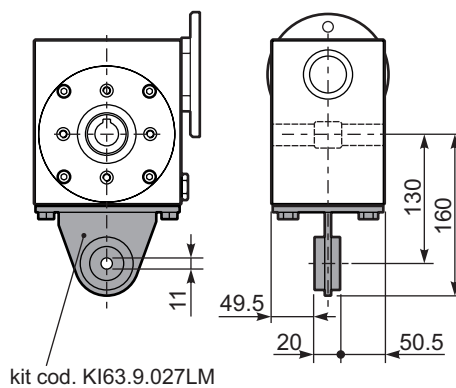

PI63.....S... Single Shaft
Albero lento semplice
kit cod. KI63.0.209
Protection cup (on request)
A richiesta coperchio di protezione

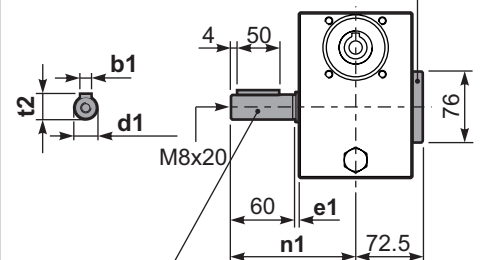

kit cod. KI063.5.028
kit cod. KI070.5.028 On request

	b1	e1	d1	n1	t2
Standard	8	3.2	25 ^{-0.005} / _{-0.020}	121.9	28
On request	8	3.5	28 ^{-0.005} / _{-0.020}	122.2	31



QUICK SELECTION / Selezione veloce

input speed (n_1) = 1400 min⁻¹

Output Speed n_2 [min ⁻¹]	Ratio i	Motor power P_{1M} [kW]	Output torque M_{2M} [Nm]	Service factor f.s.	Nominal power P_{1R} [kW]	Nominal torque M_{2R} [Nm]	Available B5 motor flanges		Available B14 motor flanges	Dynamic efficiency	Tooth Module [mm]	Ratios code
							D	E	U			
200	7	4.0	168	1.5	6.1	257	B	B		88	4.23	01
140	10	4.0	218	1.3	5.2	284	B	B		80	4.2	02
100	14	3.0	223	1.4	4.1	305	B	B		78	4.5	03
70	20	2.2	237	1.2	2.7	294	B	B		79	3.4	04
64	22	2.2	258	1.1	2.5	294	B	B		78	3.1	05
50	28	2.2	315	1.1	2.4	347	B	B		75	4.7	06
37	38	1.5	276	1.2	1.8	336	B	B		71	3.5	07
30	46	1.5	320	1.0	1.5	326	B	B		68	3.1	08
27	52	1.1	258	1.1	1.2	289	B	B		66	2.7	09
21	67	1.1	327	0.9	0.97	289	B	B		65	2.1	10
18.9	74	0.75	220	1.2	0.91	268	B	B		58	1.9	11
14.6	96	0.55	191	1.3	0.70	242	B	B		53	1.5	12

* The nominal power should be reduced if the ambient temperature is $\geq 30^\circ\text{C}$, or when a cooler gearbox is required.

* Diminuire la potenza nominale in caso di temperatura ambiente $\geq 30^\circ\text{C}$ o se è richiesta una bassa temperatura di utilizzo del riduttore.

Motor Flanges Available
Flange Motore Disponibili

B) Supplied with Reduction Bushing
Fornito con Bussola di Riduzione

B) Available on Request without reduction bushing
Disponibile a Richiesta senza Bussola di Riduzione

C) Motor Flange Holes Position
Posizione Fori Flangia Motore

EN Unit **185** is supplied with synthetic oil, providing "long life" lubrication. For mounting position V5-V6 please contact us. See table 1 for lubrication and recommended quantity. In table 2 please see possible radial loads and axial loads on the gearbox.

I Il riduttore tipo **185** viene fornito lubrificato a vita con olio sintetico. Per posizioni V5-V6 contattare il ns. servizio tecnico. Vedi tab.1 per oli e quantità consigliati. In tab.2 sono presenti i carichi radiali e assiali applicabili al riduttore.

D Für die Lebensdauerschmierung ist das Getriebe der Größe **185** mit synthetischem Öl befüllt. Bei Einbaulage V5 oder V6 bitten wir um Rücksprache. In Tabelle 1 ist die Schmiermenge und das empfohlene Schmiermittel angegeben. In Tabelle 2 sind die zulässigen Radial - und Axialbelastungen des Getriebes aufgeführt.

F Le réducteur de type **185** est fourni lubrifié à vie avec de l'huile synthétique. Concernant les positions V5.V6, contactez notre service d'assistance technique. Voir tableau 1 concernant les huiles et les quantités conseillées. Les charges radiales et axiales applicables au réducteur sont précisées dans le tableau 2.

E El reductor tamaño **185** se suministra, lubricado de por vida con aceite sintético. Para las posiciones V5 y V6 contactar con nuestro servicio técnico. Ver tabla 1, para cantidades y aceites recomendados. En la tabla 2, se encuentran las cargas radiales y axiales admitidas por el reductor.

Standard			On request		
B3	B6	B7	B8	V5	V6
2.10 LT	1.50 LT	1.50LT	2.10 LT	2.10 LT	2.10 LT
AGIP Telium VSF 320			SHELL Omala S4 WE 320		

For all details on lubrication and plugs check our website **tab. 1**
Per maggiori dettagli su lubrificazione e tappi olio vedi il nostro sito web

RADIAL AND AXIAL LOADS

Output shaft
Albero di uscita

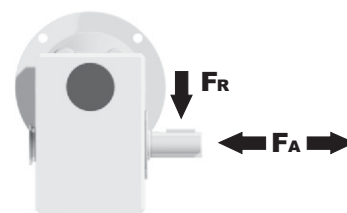

n_2 [min ⁻¹]	FA [N]	FR [N]
200	500	2500
150	580	2900
100	600	3000
75	700	3500
50	800	4000
25	1000	5000
15	1160	5800

Input shaft
albero in entrata

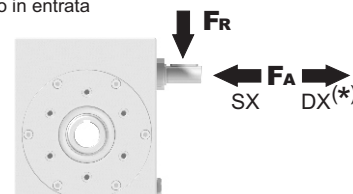

n_1 [min ⁻¹]	FA [N]	FR [N]
1400	160	809

*Strong axial loads in the DX direction are not allowed.
Non sono consentiti forti carichi assiali con direzione DX

tab. 2

Gearbox weight
peso riduttore **23.3 kg**

PI85UN... Basic wormbox
Riduttore base

M. flanges	Kit code	øF	A
80-90B5	KI85.4.042	200	118
100-112B14	KI85.4.041	160	116

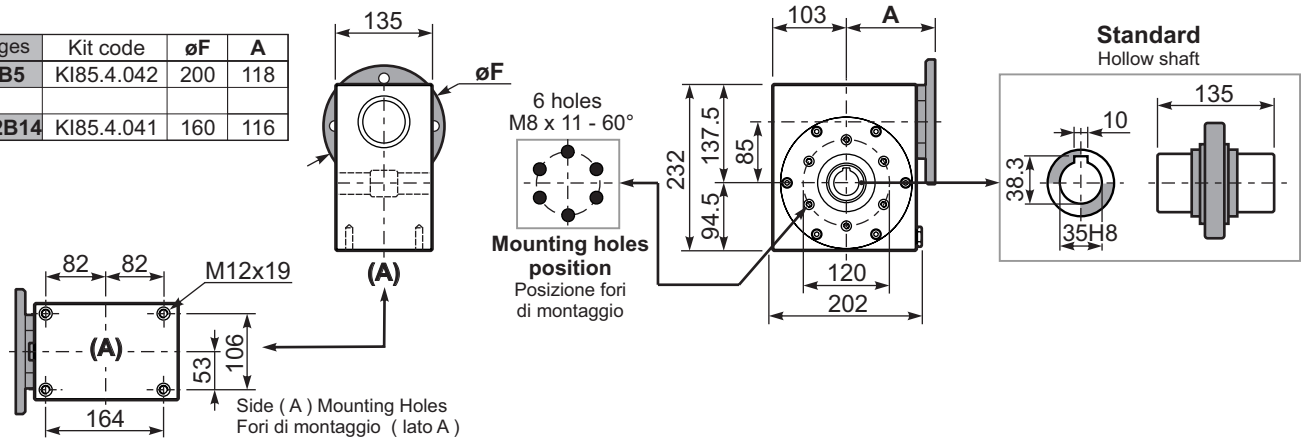

BI85UN... Modular base
Base modulare

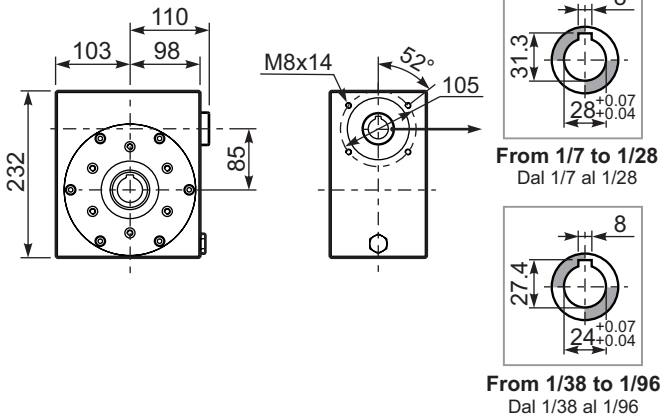

PI85FL... Output flange
Flangia uscita

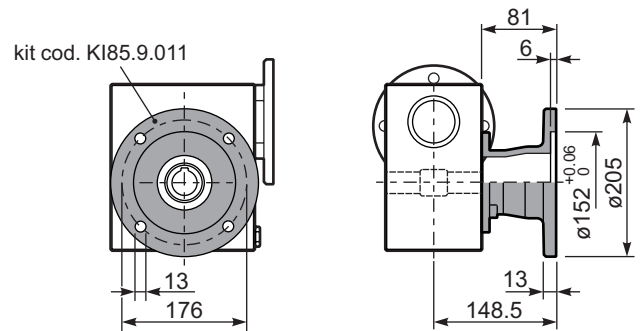

RI85UN... Input shaft
Albero in entrata

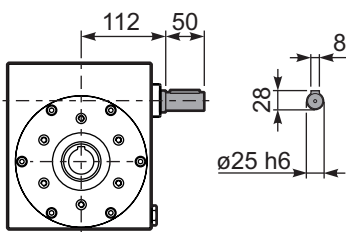

PI85BR... Reaction arm
Braccio di reazione

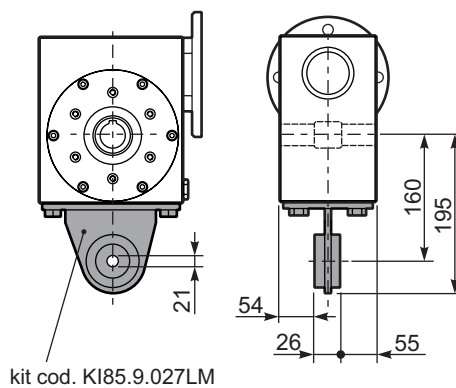

PI85.....S... Single Shaft
Albero lento semplice

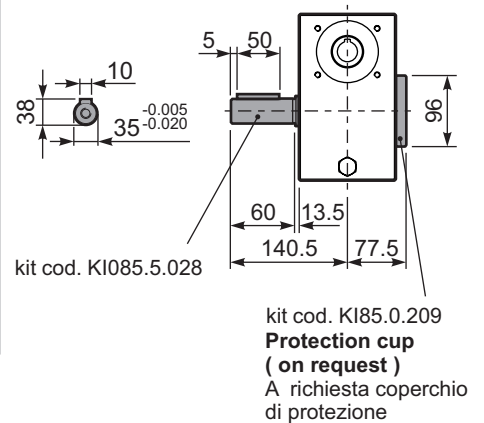



QUICK SELECTION / Selezione veloce

input speed (n_1) = 1400 min⁻¹

Output Speed n_2 [min ⁻¹]	Ratio i	Motor power P_{1M} [kW]	Output torque M_{2M} [Nm]	Service factor f.s.	Nominal power P_{1R} [kW]	Nominal torque M_{2R} [Nm]	Available B5 motor flanges		Available B14 motor flanges	Dynamic efficiency	Tooth Module $[mm]$	Ratios code
							D	E	U			
200	7	4.0	168	2.9	11.5	483	B	B		RD	5.5	01
140	10	4.0	235	2.2	9.0	525	B	B		RD	5.4	02
88	16	4.0	358	1.5	6.0	536	B	B		RD	5.3	03
70	20	4.0	447	1.2	4.9	546	B	B		RD	4.5	04
61	23	3.0	377	1.4	4.1	515	B	B		RD	3.9	05
47	30	3.0	467	1.4	4.2	651	B	B		RD	5.6	06
37	38	3.0	583	1.1	3.3	641	B	B		RD	4.7	07
31	45	2.2	493	1.2	2.7	599	B	B		RD	4.0	08
26	53	2.2	557	1.1	2.5	620	B	B		RD	3.5	09
22	64	1.5	452	1.2	1.8	536	B	B		RD	2.9	10
16.7	84	1.1	410	1.2	1.3	494	B	B		RD	2.2	11
14.1	99	1.1	446	1.1	1.2	483	B	B		RD	1.9	12

* The nominal power should be reduced if the ambient temperature is $\geq 30^\circ C$, or when a cooler gearbox is required.

* Diminuire la potenza nominale in caso di temperatura ambiente $\geq 30^\circ C$ o se è richiesta una bassa temperatura di utilizzo del riduttore.

Motor Flanges Available
Flange Motore Disponibili

B) Supplied with Reduction Bushing
Fornito con Bussola di Riduzione

B) Available on Request without reduction bushing
Disponibile a Richiesta senza Bussola di Riduzione

C) Motor Flange Holes Position
Posizione Fori Flangia Motore

EN Unit I11 is supplied with synthetic oil, providing "long life" lubrication. For mounting position V5-V6 please contact us. See table 1 for lubrication and recommended quantity. In table 2 please see possible radial loads and axial loads on the gearbox.

I Il riduttore tipo I11 viene fornito lubrificato a vita con olio sintetico. Per posizioni V5-V6 contattare il ns. servizio tecnico. Vedi tab.1 per oli e quantità consigliati. In tab.2 sono presenti i carichi radiali e assiali applicabili al riduttore.

D Für die Lebensdauerschmierung ist das Getriebe der Größe I11 mit synthetischem Öl befüllt. Bei Einbaulage V5 oder V6 bitten wir um Rücksprache. In Tabelle 1 ist die Schmiermenge und das empfohlene Schmiermittel angegeben. In Tabelle 2 sind die zulässigen Radial - und Axialbelastungen des Getriebes aufgeführt.

F Le réducteur de type I11 est fourni lubrifié à vie avec de l'huile synthétique. Concernant les positions V5.V6, contactez notre service d'assistance technique. Voir tableau 1 concernant les huiles et les quantités conseillées. Les charges radiales et axiales applicables au réducteur sont précisées dans le tableau 2.

E El reductor tamaño I11 se suministra, lubricado de por vida con aceite sintético. Para las posiciones V5 y V6 contactar con nuestro servicio técnico. Ver tabla 1, para cantidades y aceites recomendados. En la tabla 2, se encuentran las cargas radiales y axiales admitidas por el reductor.

Standard	On request				
3.50 LT	2.50 LT	2.50 LT	2.10 LT	1.60 LT	1.60 LT
AGIP Telium VSF 320			SHELL Omala S4 WE 320		

For all details on lubrication and plugs check our website [tab. 1](#)
Per maggiori dettagli su lubrificazione e tappi olio vedi il nostro sito web

RADIAL AND AXIAL LOADS

Output shaft

Albero di uscita

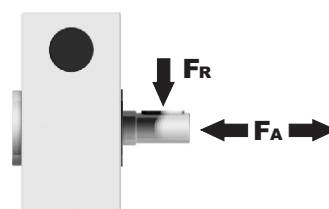

n_2 [min ⁻¹]	FA [N]	FR [N]
200	600	2900
150	700	3300
100	750	3600
75	800	4000
50	920	4600
25	1200	6000
15	1400	7000

Input shaft

albero in entrata

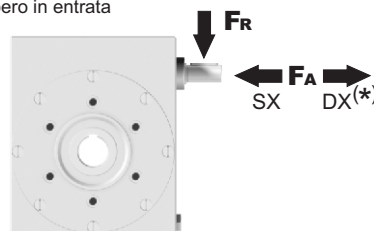

n_1 [min ⁻¹]	FA [N]	FR [N]
1400	228	1140

*Strong axial loads in the DX direction are not allowed.
Non sono consentiti forti carichi assiali con direzione DX

tab. 2

Gearbox weight
peso riduttore **38.5 kg**

PI11UN... Basic wormbox
Riduttore base

M. flanges	Kit code	øF	A
80-90B5	KI85.4.042	200	137.5
100-112B14	KI85.4.041	160	135.5

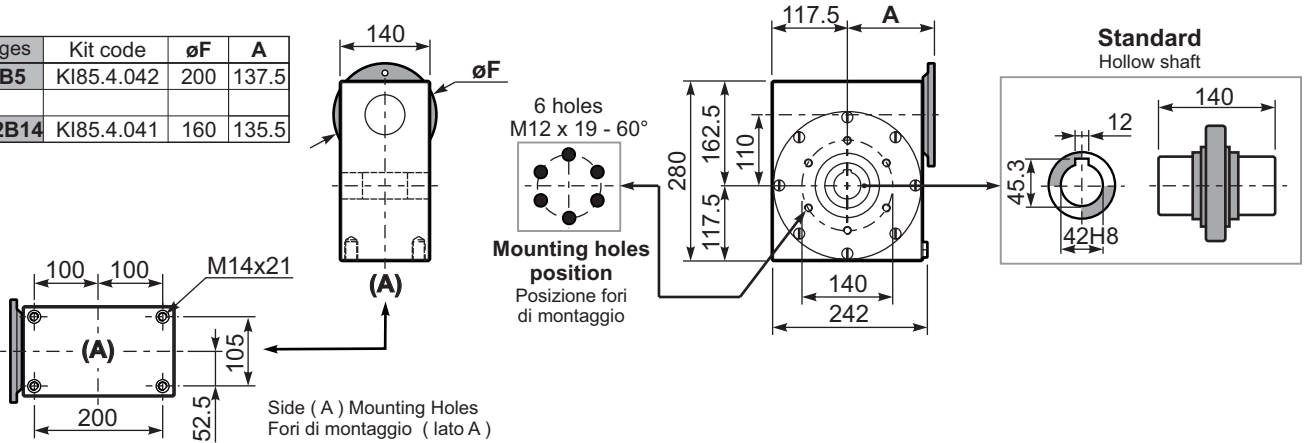

BI11UN... Modular base
Base modulare

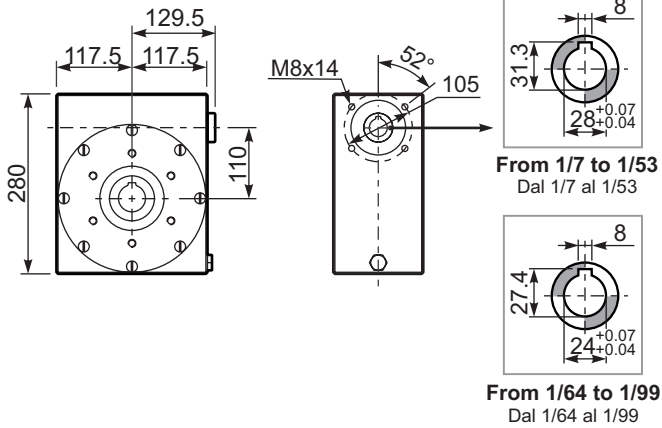

PI11BR... Reaction arm
Braccio di reazione

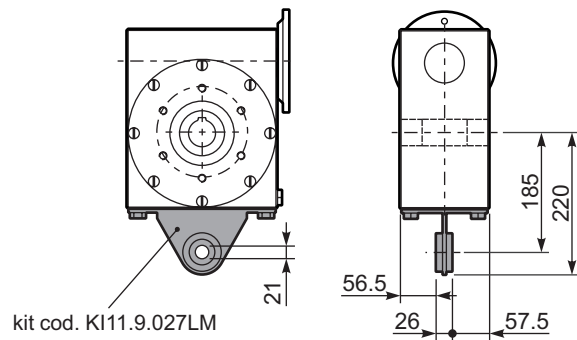

RI11UN... Input shaft
Albero in entrata

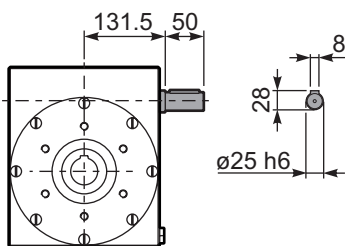

Stainless steel one step gearboxes

A modular and compact product

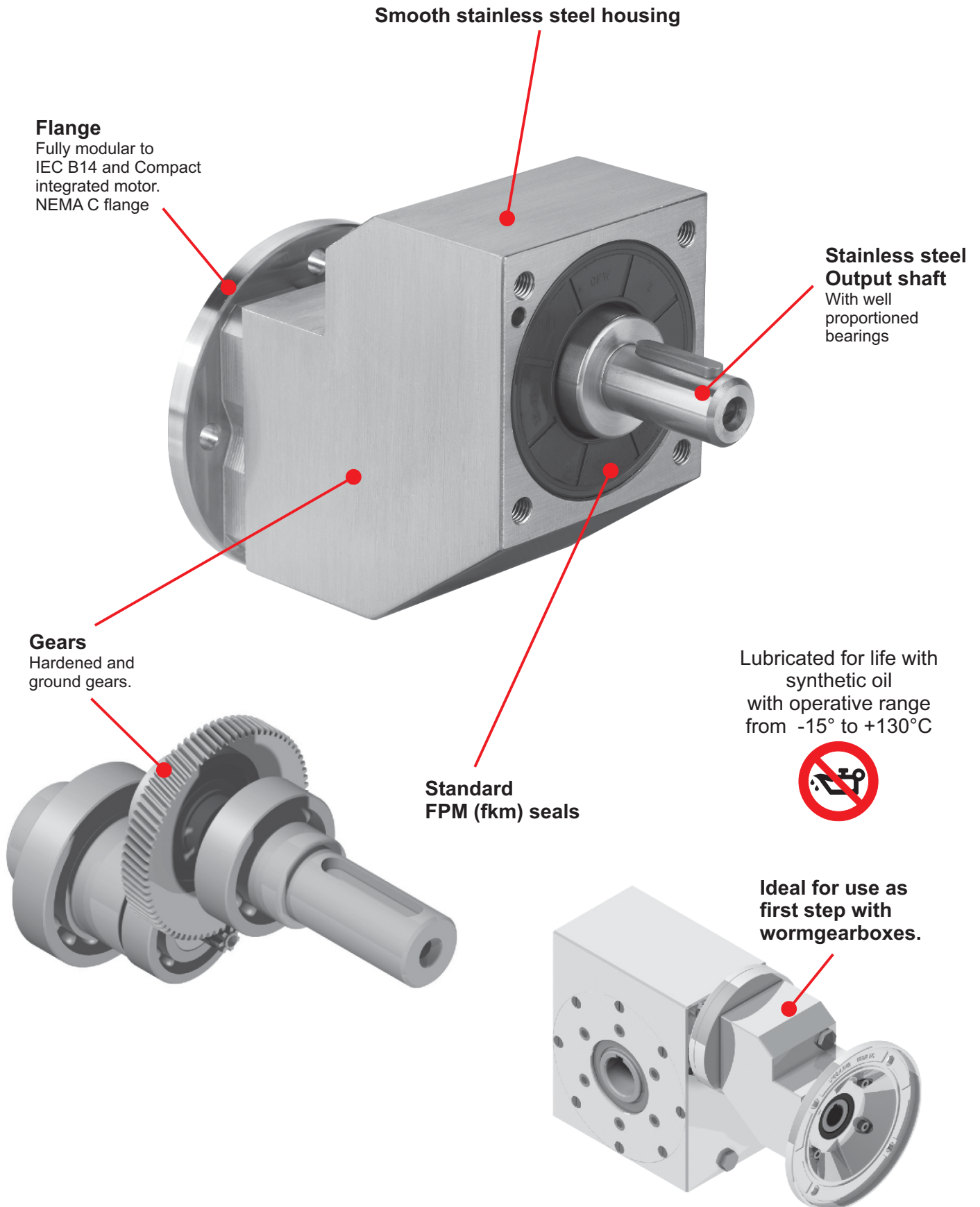

Specific type datasheet on page...

On page / A pagina / Auf Seite / À la page / En la página

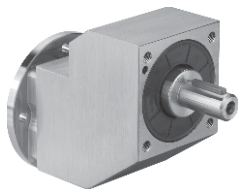

Types / Tipi /
Tipen / Types /
Tipos →

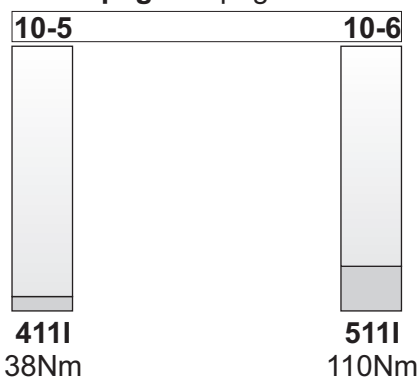

On page / A pagina / Auf Seite / À la page / En la página



Types / Tipi /
Tipen / Types /
Tipos →

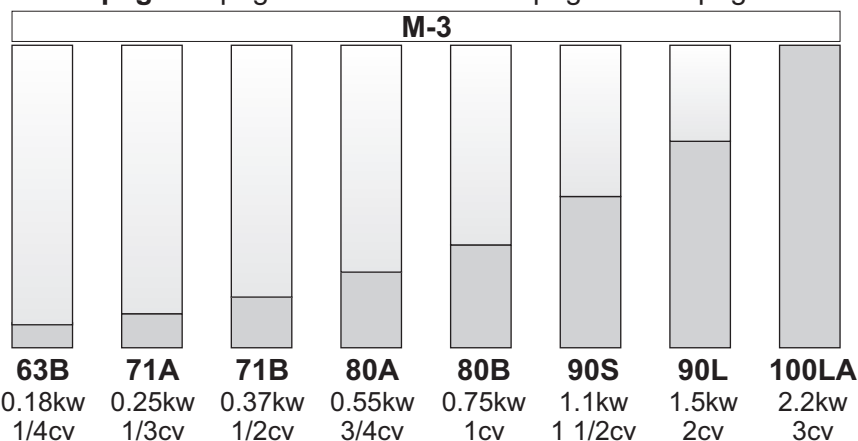

CODIFICA / HOW TO ORDER / TYPENBEZEICHNUNGEN / CODIFICATION / CODIFICACIÓN

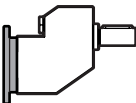
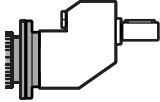
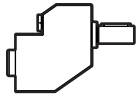
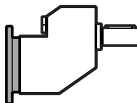
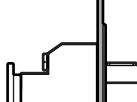
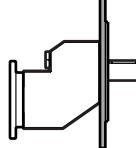
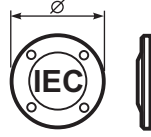
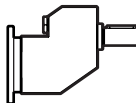
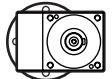
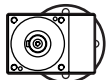
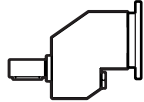
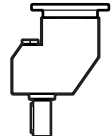
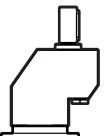
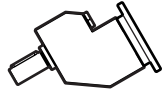
Type - Tipo Typ Type - Tipo	Size - Grandezza Grösse - Taille Tamaño	Mounting Montaggio Montage Fixation Tipo de montaje	Ratio - Rapporto Untersetzung Reduction Relación	Output shaft Albero lento Abtriebswelle Arbre de sortie Eje solida	Output flange Flangia uscita Ausgangsflansch Bride de sortie Brida en salida	Motor size Grandezza motore Motor Grösse Grandeur moteur Tamaño motor	Mounting position Posizione montaggio Einbaulage Position de montage Position de montage
P	411I 511I	-F	1.57	C	4	-Q	B3
 P  M  B	<div style="border: 1px solid black; padding: 5px; text-align: center;"> 411I 511I </div>	 -N  -F	<p>See technical data table</p> <p>Vedi tabella dati tecnici.</p> <p>Technisches Datenblatt beachten</p> <p>Voir Tableau données techniques</p> <p>Ver tabla datos técnicos</p>	<p>→ STANDARD</p> <div style="border: 1px solid black; padding: 2px; margin-bottom: 5px;">411I</div> <p>C → ∅19</p> <div style="border: 1px solid black; padding: 2px; margin-bottom: 5px;">511I</div> <p>G → ∅28</p>	 N Senza flangia Without flange <div style="border: 1px solid black; padding: 2px; margin-bottom: 5px;">411I</div> <p>4 → ∅200</p> <div style="border: 1px solid black; padding: 2px; margin-bottom: 5px;">511I</div> <p>5 → ∅250</p>	 <div style="border: 1px solid black; padding: 2px; margin-bottom: 5px;">411I</div> <p>-Q 71B14 (∅105)</p> <p>-R 80B14 (∅120)</p> <p>-T 90B14 (∅140)</p> <div style="border: 1px solid black; padding: 2px; margin-bottom: 5px;">511I</div> <p>-D 80B5 (∅200)</p> <p>-E 90B5 (∅200)</p> <p>-U 100-112 B14 (∅160)</p> <p>Without flange Senza flangia</p> <div style="border: 1px solid black; padding: 2px; margin-bottom: 5px;">411I</div> <p>-1 ⇒ ∅14 (71B5)</p> <p>-2 ⇒ ∅19 (80B5)</p> <p>-3 ⇒ ∅24 (90B5)</p> <div style="border: 1px solid black; padding: 2px; margin-bottom: 5px;">511I</div> <p>-2 ⇒ ∅19 (80B5)</p> <p>-3 ⇒ ∅24 (90B5)</p> <p>-4 ⇒ ∅28 (100B5)</p>	 B3 STANDARD  B6  B7  B8  V5  V6  V8

On request

B Food lube

- B3 is supplied with standard oil quantity
- Please specify in the order if you required other mounting positions

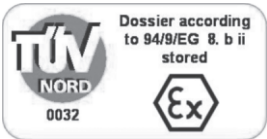

On request we can deliver our products according to the ATEX
 A richiesta possiamo fornire i nostri prodotti secondo le normative ATEX
 Auf Anfrage können wir unsere Produkte den Richtlinien ATEX entsprechend liefern
 Sur demande nos produits peuvent se conformer à la réglementation ATEX
 A pedido, se pueden enviar nuestros productos de acuerdo con las normas ATEX.

POTENZA RICHIESTA / REQUIRED POWER / ERFORDERLICHE LEISTUNG / PUISSANCE NECESSAIRE / POTENCIA NECESARIA

Lifting / sollevamento / hubantriebe / levage / elevación

$$P \text{ [KW]} = \frac{M \text{ [Kg]} \cdot g \text{ [9.81]} \cdot v \text{ [m / s]}}{1000}$$

Rotation / rotazione / drehung / rotation / rotação

$$P \text{ [KW]} = \frac{M \text{ [Nm]} \cdot n \text{ [rpm]}}{9550}$$

Linear movement / traslazione / linearbewegung / translation / translación

$$P \text{ [KW]} = \frac{F \text{ [N]} \cdot v \text{ [m / s]}}{1000}$$

TORQUE / COPPIA / DREHMOMENT / COUPLE / PAR

$$M \text{ [Nm]} = \frac{9550 \cdot P \text{ [KW]}}{n \text{ [rpm]}}$$

$$M \text{ [lb in]} = \frac{63030 \cdot P \text{ [HP]}}{n \text{ [rpm]}}$$

RADIAL LOADS / CARICHI RADIALI / RADIALE - UND AXIALLASTEN / CHARGES RADIALES / CARGA RADIAL Y AXIAL

- Radial load generated by external transmissions keyed onto input and/or output shafts.
- Forza radiale generata da organi di trasmissione calettati sugli alberi di ingresso e/o uscita.
- Belastungen der Antriebs- bzw. Abtriebswellen durch von aussen eingebrachte Radiallasten.
- Charge radiale générée par la transmissions calés sur les entrées et / ou des arbres de sortie
- Cargas radiales, generada por transmisiones externas, aplicadas sobre los ejes de entrada y/o salida

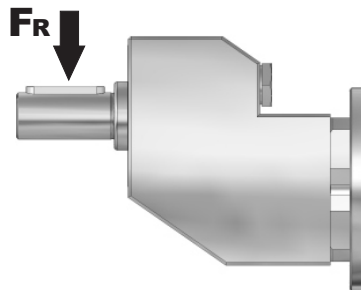

	$F_R \text{ [N]} = \frac{M \text{ [Nm]} \cdot 2000}{d \text{ [mm]}} \cdot f_k$	$F_R \text{ [N]} = \frac{M \text{ [lb in]} \cdot 8.9}{d \text{ [in]}} \cdot f_k$
M	Momento torcente / Output torque / Abtriebsdrehmoment / Couple / Par torsion	
d	Diametro primitivo / Diam. of driving element / Durchmesser der Abtriebseinheit / Diamètre primitif / Diámetro primitivo	
f_k	Coefficiente di trasformazione / Factor / Faktor / Coefficient de transmission / Coeficiente de transmisión 1.15 Ingranaggi / Gearwheels / Zahnrad / Engrenage / Engranaje 1.25 Catena / Chain sprockets / Antriebskette / Chaîne / Cadena 1.75 Cinghia Trapezoidale / Narrow v-belt pulley / Keilriemen / Courroie trap. / Correa trapezoidal 2.50 Cinghia piatta / Flat-belt pulley / Flachzahnriem. / Courroie crantée / Correa plana	

- If your application requires higher radial loads, contact our technical office. Higher load may be possible.
- Nel caso la vostra applicazione richieda carichi radiali superiori consultare il nostro ufficio tecnico, valori maggiori possono essere accettati.
- Wenn Ihre Anwendung höhere Radialbelastungen erfordert, so wenden Sie sich bitte an unser technischen Büro.
- Si votre application demande des charges radiales supérieures, s'adresser à notre bureau technique.
- En el caso en que una aplicación exija una carga radial superior a la especificada en el catálogo, consultar a nuestra oficinas técnica.

How to select a gearbox / Come selezionare un riduttore / Wie wählt man ein Getriebe
Comment sélectionner un réducteur / Cómo seleccionar un reductor

B Output speed
Velocità in uscita
Abtriebsdrehzahl
Vitesse de sortie
Velocidad de salida

Nominal power
Potenza nominale
Max. mögliche Leistung
Poissance nominale
Potencia nominal

A Nominal torque
Momento torcente nominale
Nenn Drehmoment
Couple nominal
Par de torsión nominal

Flange code
Codice flangia
Flanschtype
Code bride
Código bridas

Input speed
Velocità in entrata
Eintriebsdrehzahl
Vitesse en entrée
Velocidad de entrada

Gear size
Grandezza riduttore
Getriebegröße
Taille réducteur
Tamaño reductor

Motor power
Potenza motore
Motorleistung
Puissance moteur
Potencia motor

4111

One step 38Nm

Rating - Stainlesssteel ONE STEP GEARBOXES

QUICK SELECTION / Selezione veloce							input speed (n ₁) = 1400 min ⁻¹									
Output Speed n ₂ [min ⁻¹]	Ratio i	Motor power P _{1M} [kW]	Output torque M _{2M} [Nm]	Service factor f.s.	Nominal power P _{1R} [kW]	Nominal torque M _{2R} [Nm]	B5 motor flanges not available				Available B14 motor flanges			Output Shaft		
							-	-	-	-	Q	R	T			Notes
892	1.57	1.5	15.7	1.3	1.90	20	-	-	-	-	C	C		2844	standard ø19	01
493	2.84	1.5	28.4	1.2	1.84	35	-	-	-	-	C	C		1954		02
426	3.29	1.5	32.9	1.2	1.73	38	-	-	-	-	C	C		1756		03
362	3.87	1.5	38.7	1.0	1.54	40	-	-	-	-	C	C		1558		04

C Ratio
Rapporto
Untersetzung
Rapport de réduction
Relación

Transmitted torque
Momento torcente trasmesso
Mögliche Drehmomente
Couple de sortie
Par transmitido

Service factor
Fattore di servizio
Betriebsfaktor
Facteur de service
Factor de servicio

Output shaft diam.
Diam. albero uscita
Durchmesser abtriebswelle
Diametre arbre lent
Diametro eje de salida

Notes
Note
Anmerkungen
Note
Notas

Type of load and starts per hour Tipo di carico e avviamenti per ora		Oper. hours per day Ore di funz. giorn.		
		3 h	10 h	24 h
Continuous or intermittent appl. with start / hour Applicazione cont. o interm. con n.ro operazioni/ora	Uniform / Uniforme	0.8	1	1.25
	Moderate / Moderato	1	1.25	1.5
	Heavy / Forte	1.25	1.5	1.75
Intermittent application with start / hour Applicazione intermittente con n.ro operazioni/ora	Uniform / Uniforme	1	1.25	1.5
	Moderate / Moderato	1.25	1.5	1.75
	Heavy / Forte	1.5	1.75	2.15

D	Motor flange available Flange disponibili Erhältliche Motorflansche Brides disponibles Bridas disponibles	
B)	Mounting with reduction ring Montaggio con boccola di riduzione Reduzierhülsen Montage avec douille de réduction Montaje con casquillo de reducción	
C)	Motor flangeholes position/terminal box position Posizione fori flangia/basetta motore Bohrungsposition am Motorflansch/-sockel Position trous bride/barrette à bornes moteur Posición agujeros brida / base motor	
B)	Available without reduction bushes Disponibile anche senza boccola Auch ohne Reduzierbuchse verfügbar Disponible aussi sans douille de réduction Disponible también sin casquillo	

A	Select required torque (according to service factor)	Seleziona la coppia desiderata (comprensiva del fattore di servizio)	Max. Drehmoment in Bezug zum Betriebsfaktor	Sélectionner le couple souhaité (comprenant le facteur de service)	Seleccionar el par deseado (incluyendo el factor de servicio)
B	Select output speed	Seleziona la velocità in uscita	Ausgewählte Abtriebsdrehzahl	Sélectionner la vitesse de sortie	Seleccionar la velocidad de salida
C	On the same line of selected geared motor, you can find the gear ratio	Sulla riga corrispondente alla motorizzazione prescelta si può rilevare il rapporto di riduzione	Auf der gleichen Linie wie die ausgewählte Motorleistung steht auch die Getriebeuntersetzung	Sur la ligne correspondante à la motorisation pré-choisie on peut relever le rapport de réduction	En la línea correspondiente al motor preseleccionado es posible encontrar la relación de reducción
D	Select motor flange available (if requested)	Scegli la flangia disponibile (se richiesta)	Erhältliche Motorflansche (auf Anfrage)	Choisir la bride disponible (si elle est demandée)	Seleccionar la brida disponible (sobre pedido)



QUICK SELECTION / Selezione veloce

input speed (n_1) = 1400 min⁻¹

Output Speed n_2 [min ⁻¹]	Ratio i	Motor power P_{1M} [kW]	Output torque M_{2M} [Nm]	Service factor f.s.	Nominal power P_{1R} [kW]	Nominal torque M_{2R} [Nm]	B5 motor flanges not available				Available B14 motor flanges			Output Shaft 	Ratios code	
							-	-	-	-	Q	R	T			
891	1.57	1.5	16	1.3	1.9	20	-	-	-	-	C	C		2844	standard ø19	01
493	2.84	1.5	28	1.2	1.8	35	-	-	-	-	C	C		1954		02
425	3.29	1.5	33	1.2	1.7	38	-	-	-	-	C	C		1756		03
362	3.87	1.5	39	1.0	1.5	40	-	-	-	-	C	C		1558		04
303	4.62	1.5	46	1.0	1.5	47	-	-	-	-	C	C		1360		05
222	6.30	1.1	46	1.0	1.1	46	-	-	-	-	C	C		1063		06
170	8.22	0.55	30	1.3	0.69	38	-	-	-	-	C	C		974		07
129	10.86	0.37	27	1.0	0.39	28	-	-	-	-	C	C		776		08

The dynamic efficiency is **0.98** for all ratios

* The nominal power should be reduced if the ambient temperature is $\geq 30^\circ\text{C}$, or when a cooler gearbox is required.

* Diminuire la potenza nominale in caso di temperatura ambiente $\geq 30^\circ\text{C}$ o se è richiesta una bassa temperatura di utilizzo del riduttore.

Motor Flanges Available
Flange Motore Disponibili

B) Supplied with Reduction Bushing
Fornito con Bussola di Riduzione

B) Available on Request without reduction bushing
Disponibile a Richiesta senza Bussola di Riduzione

C) Motor Flange Holes Position
Posizione Fori Flangia Motore

EN Unit 4111 is supplied with synthetic oil for lifetime lubrication, no maintenance is necessary.

I Il riduttore 4111 viene fornito completo di olio sintetico per la lubrificazione permanente e non necessita di alcuna manutenzione.

D Das Getriebe 4111 ist mit synthetischem Öl gefüllt und ist lebensdauer geschmiert.

F Le réducteur 4111 est fourni complet avec de l'huile synthétique pour la lubrification permanente et ne nécessite aucun entretien.

E El reductor tamaño 4111 se suministra, lubricado de por vida con aceite sintético y no requieren mantenimiento alguna.

LUBRICATION 4111 Oil Quantity 0.14 Lt.

AGIP Telium VSF 320

SHELL Omala S4 WE 320

For all details on lubrication and plugs check our website

Per maggiori dettagli su lubrificazione e tappi olio vedi il nostro sito web

Output shaft / Albero di uscita

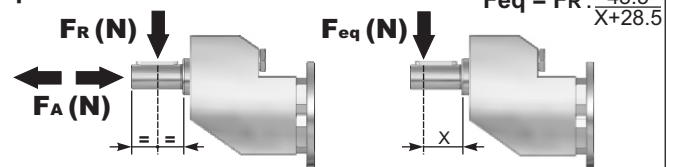

n_2	FA	FR	n_2	FA	FR	n_2	FA	FR
700	182	910	400	230	1150	200	290	1450
600	100	1000	300	250	1250	140	320	1600

P4111-N... Basic gearbox
Riduttore base

Gearbox weight
peso riduttore **5.5 kg**

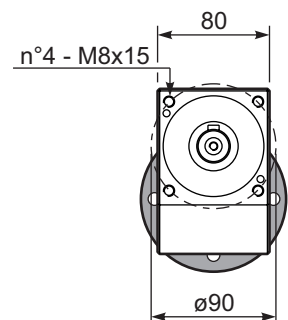
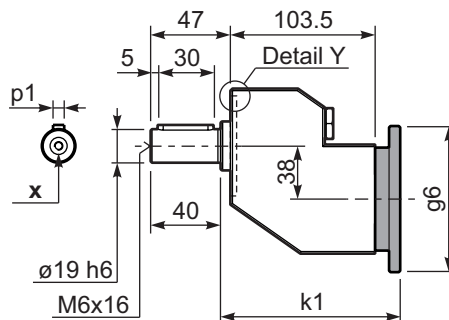
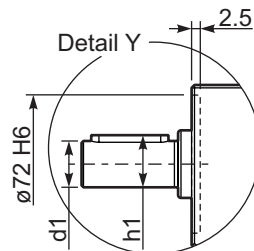

Output shafts / albero di uscita

	Shaft - d1	p1	h1	x
Standard	ø 19x40	6	21.5	M6x16

P4111-F... Output flange
flangia di uscita

Input flanges / flange di entrata

	k1	g6	kit code
71 B14	128.5	105	KI63.4.047
80 B14	129.5	120	KI63.4.046
90 B14	130.5	140	KI63.4.041

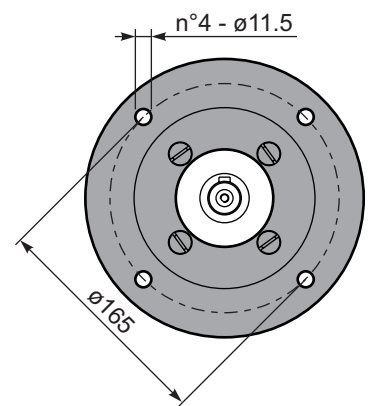
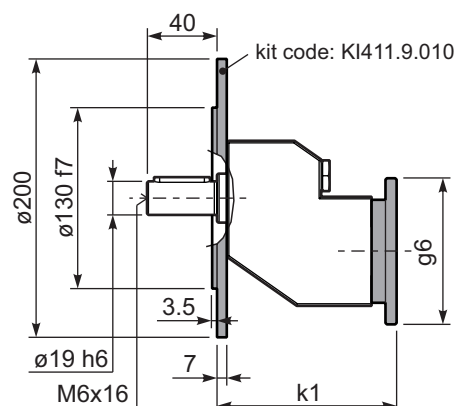



QUICK SELECTION / Selezione veloce

input speed (n_1) = 1400 min⁻¹

Output Speed n_2 [min ⁻¹]	Ratio i	Motor power P_{1M} [kW]	Output torque M_{2M} [Nm]	Service factor f.s.	Nominal power P_{1R} [kW]	Nominal torque M_{2R} [Nm]	Available B5 motor flanges		Available B14 motor flanges	Output Shaft			
							D	E	U				Ratio code
1077	1.30	4	34	1.2	4.6	40							
571	2.45	4	64	1.1	4.3	70							
423	3.31	4	87	1.0	4.1	90							
325	4.31	4	113	1.0	3.8	110							
266	5.27	3	104	1.1	3.1	110							
184	7.63	2.2	111	1.0	2.2	110							
133	10.50	1.1	77	1.0	1.1	80							

The dynamic efficiency is **0.98** for all ratios

* The nominal power should be reduced if the ambient temperature is $\geq 30^\circ\text{C}$, or when a cooler gearbox is required.

* Diminuire la potenza nominale in caso di temperatura ambiente $\geq 30^\circ\text{C}$ o se è richiesta una bassa temperatura di utilizzo del riduttore.

Motor Flanges Available
Flange Motore Disponibili

B) Supplied with Reduction Bushing
Fornito con Bussola di Riduzione

B) Available on Request without reduction bushing
Disponibile a Richiesta senza Bussola di Riduzione

C) Motor Flange Holes Position
Posizione Fori Flangia Motore

EN Unit 5111 is supplied with synthetic oil for lifetime lubrication, no maintenance is necessary.

I Il riduttore 5111 viene fornito completo di olio sintetico per la lubrificazione permanente e non necessita di alcuna manutenzione.

D Das Getriebe 5111 ist mit synthetischem Öl gefüllt und ist lebensdauergeschmiert.

F Le réducteur 5111 est fourni complet avec de l'huile synthétique pour la lubrification permanente et ne nécessite aucun entretien.

E El reductor tamaño 5111 se suministra, lubricado de por vida con aceite sintético y no requieren mantenimiento alguna.

LUBRICATION 5111 Oil Quantity 0.45 Lt.

AGIP Telium VSF 320

SHELL Omala S4 WE 320

For all details on lubrication and plugs check our website

Per maggiori dettagli su lubrificazione e tappi olio vedi il nostro sito web

Output shaft / Albero di uscita

F_R (N) F_A (N) F_{eq} (N) $F_{eq} = F_R \cdot \frac{65.5}{X+35.5}$

n_2	F_A	F_R	n_2	F_A	F_R	n_2	F_A	F_R
700	294	1470	400	370	1850	200	460	2300
600	320	1600	300	400	2000	140	510	2550

P5111-N... Basic gearbox
Riduttore base

Gearbox weight
peso riduttore **12.0 kg**

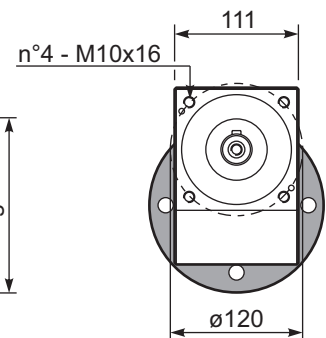
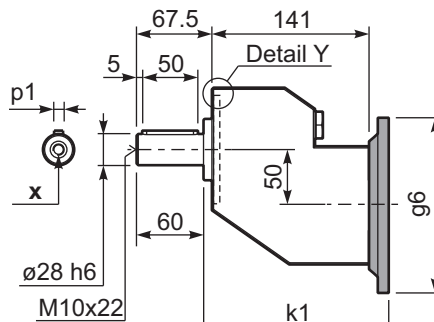
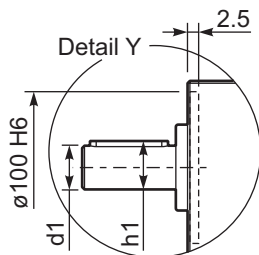

Output shafts / albero di uscita

	Shaft - d1	p1	h1	x
Standard	28x60	8	31	M10x22

P5111-F... Output flange
flangia di uscita

Input flanges / flange di entrata

	k1	g6	kit code
80-90B5	168.5	200	KI85.4.042
100-112B14	166.5	160	KI85.4.041

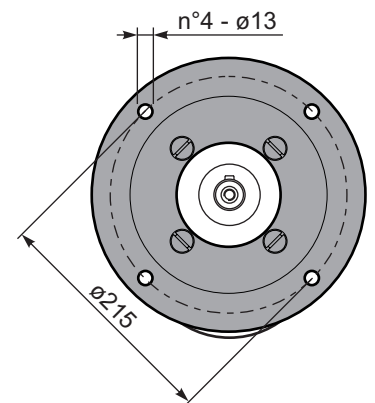
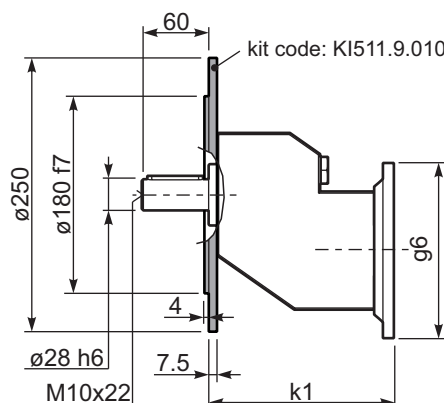



- 1) 230/400V - 50Hz three-phase asynchronous induction motor
- 2) Class F insulation
- 3) S1 duty
- 4) IP 55 protection
- 5) Not painted
- 6) Hard plastic sleeve to protect output shaft during the transportation

- 1) 230/400V - 50Hz motore trifase asincrono
- 2) Isolamento Classe F
- 3) S1 servizio continuo
- 4) Protezione IP 55
- 5) Non verniciato
- 6) Manicotto di protezione per l'albero motore

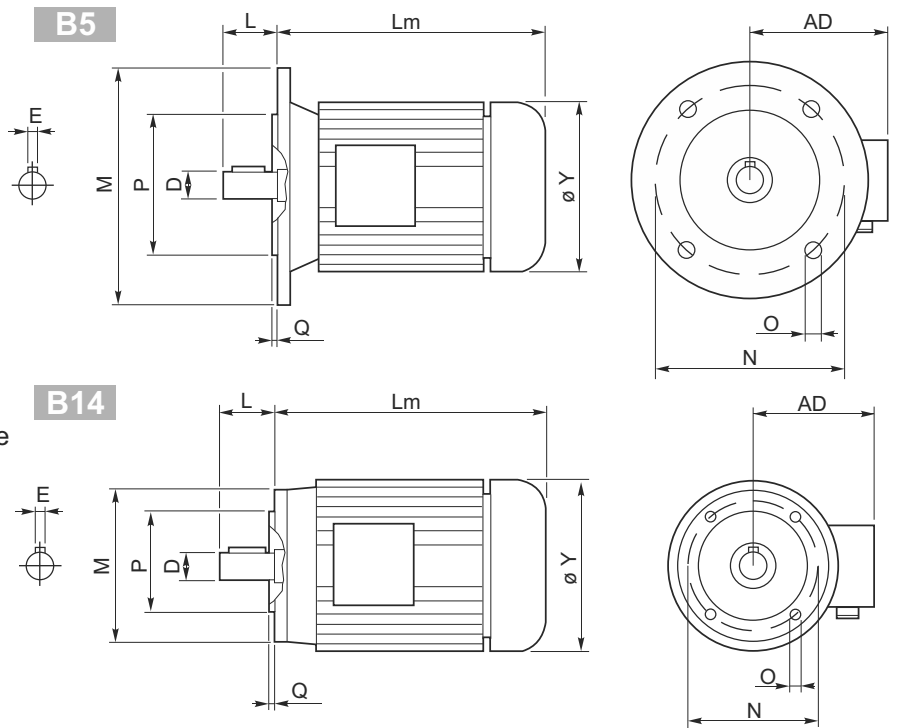

Outside dimensions may be different according to manufacturers.
 Le dimensioni esterne sono indicative, possono variare tra i vari costruttori.

	2 poli / poles			4 poli / poles			6 poli / poles			B5-B14						B5					B14					Kg
	kW	Nm	A _(400V)	kW	Nm	A _(400V)	kW	Nm	A _(400V)	D	E	L	Lm	Y	AD	P	N	M	O	Q	P	N	M	O	Q	
56 A	0.09	0.32	0.38	0.06	0.44	0.27	—	—	—	9	3	20	179	108	96	80	100	120	7	2.5	50	65	80	M5	2.5	2.7
56 B	0.12	0.42	0.46	0.09	0.67	0.37	—	—	—	9	3	20	179	108	96	80	100	120	7	2.5	50	65	80	M5	2.5	2.9
63 A	0.18	0.63	0.60	0.12	0.84	0.50	0.09	0.99	0.57	11	4	23	185	120	99	95	115	140	9.5	3	60	75	90	M5	2.5	3.8
63 B	0.25	0.87	0.76	0.18	1.30	0.69	0.12	1.32	0.74	11	4	23	185	120	99	95	115	140	9.5	3	60	75	90	M5	2.5	4.2
71 A	0.37	1.30	1.00	0.25	1.70	0.91	0.18	1.90	0.80	14	5	30	-	130	104	110	130	160	9.5	3.5	70	85	105	M6	2.5	5.9
71 B	0.55	1.90	1.54	0.37	2.52	1.14	0.25	2.72	1.10	14	5	30	225	141	107	110	130	160	9.5	3.5	70	85	105	M6	2.5	6.5
80 A	0.75	2.60	1.85	0.55	3.77	1.51	0.37	3.84	1.18	19	6	40	256	159	127	130	165	200	11.5	3.5	80	100	120	M6	3	8.5
80 B	1.1	3.90	2.64	0.75	5.11	2.57	0.55	5.84	1.80	19	6	40	256	159	127	130	165	200	11.5	3.5	80	100	120	M6	3	10
90 S	1.5	5.00	3.31	1.1	7.45	2.78	0.75	7.92	2.32	24	8	50	-	170	135	130	165	200	11.5	3.5	95	115	140	M8	3	12.5
90 L	2.2	7.50	4.46	1.5	10.2	3.61	1.1	11.6	3.45	24	8	50	280	170	135	130	165	200	11.5	3.5	95	115	140	M8	3	15
100 LA	3.0	10.0	6.28	2.2	14.8	5.07	1.5	15.4	3.88	28	8	60	-	190	148	180	215	250	13	4	110	130	160	M8	3.5	20
100 LB	—	—	—	3.0	20.1	6.66	—	—	—	28	8	60	-	190	148	180	215	250	13	4	110	130	160	M8	3.5	22
112 M	4.0	13.4	8.10	4.0	26.7	8.55	2.2	22.6	5.30	28	8	60	321	210	164	180	215	250	13	4	110	130	160	M8	3.5	35
132 S	5.5	18.3	11.2	5.5	36.5	11.4	3.0	30.2	7.20	38	10	80	375	—	—	—	—	—	—	—	—	—	—	—	—	41
	7.5	24.9	15.3	7.5	49.4	15.0	4.0	40.0	9.13	38	10	80	420	244	180	230	265	300	14	4	130	165	200	M10	4	51
132 M	—	—	—	7.5	61.4	18.5	—	—	—	38	10	80	420	244	180	230	265	300	14	4	130	165	200	M10	4	51
160 M	—	—	—	11	72	21.5	—	—	—	42	12	110	503	335	246	250	300	350	18	5	—	—	—	—	—	79.2
160 L	—	—	—	15	98	29	—	—	—	42	12	110	547	335	246	250	300	350	18	5	—	—	—	—	—	97.5
180 M	—	—	—	18.5	121	35.5	—	—	—	48	14	110	602	366	266	250	300	350	19	5	—	—	—	—	—	170
180 L	—	—	—	22	144	42	—	—	—	48	14	110	602	366	266	250	300	350	19	5	—	—	—	—	—	170



Metric electric motors are in aluminum. On request they can be supplied with different Level of protection and painted with 2 or 3 level of anticorrosive paint.

I motori metrici sono in alluminio, su richiesta possono essere forniti con differenti livelli di protezione e verniciati con vernice anticorrosiva.



Protection

Standard IP55
Please specify on purchase orders if you need a higher IP protection class.

Grado di protezione

IP55 Standard
Specificare in sede di ordinazione per IP superiore.

Schutzart

IP55 Standard.
Höheren IP Grad bitte im Auftrag angeben.

Degré de protection

IP55 standard.
Au moment de la commande, spécifiez si vous souhaitez IP supérieur.

Grado de protección
IP55 standard.
Especificar en el pedido cuando necesiten protección IP superior.

Insulation

Standard Cl.F
To be specified upon placing the order if different insulation is required.

Isolamento

Cl.F Standard
Specificare in sede di ordinazione classe di isolamento diversa.

Isolierung

Cl.F Standard.
Davon abweichende Isolierungsklas se im Auftrag angeben.

Isolement

Cl.F Standard.
Au moment de la commande, spécifiez si vous souhaitez une classe d' isolement différente.

Aislamiento

Cl.F standard.
Especificar al efectuar el pedido la clase diferente de aislamiento.

Insulation / Isolamento Isolierung /Aislamiento		E	B	F	H
Max. temp.	C°	120°	130°	155°	175°
	F*	248°	266°	311°	347°

Connections

Collegamenti

Verbindungselemente

Branchements

Conexiones

Threephase asynchronous single polarity
Asincrono trifase singola polarità
Asynchronmotor 3-ph eine Drehzahl
Moteur triphasé à une vitesse
Asincrono trifasico de una velocidad

Threephase asynchronous double polarity
Asincrono trifase doppia polarità
Asynchronmotor 3-ph doppelte Drehzahl
Moteur triphasé à deux vitesses
Asincrono trifasico de dos velocidades

Single phase asynchronous
Asincrono monofase
Einphasen-Asynchronmotor
Moteur monophasé
Asincrono monofasico

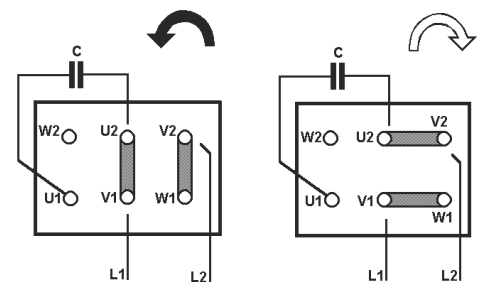
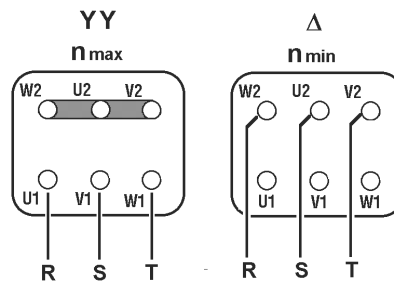
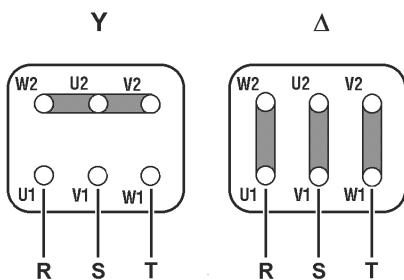



Features

- 1) 300 Series Stainless Steel Construction.
- 2) Inverter duty
- 3) Washdown Duty Applications.
- 4) BISSC Certified.
- 5) Corrosion Resistant.
- 6) Laser Etched Nameplate.
- 7) Oversized Bearings on both ends
c/w Locked Drive-end Bearing Construction.
- 8) Oversized Conduit Box c/w Lead Seal.
- 9) Drill & Tapped Drains.
- 10) T-Drain included.
- 11) Double Lip Contact Seals.

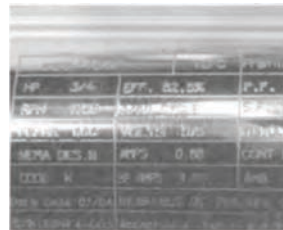
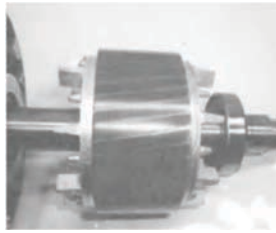

B14

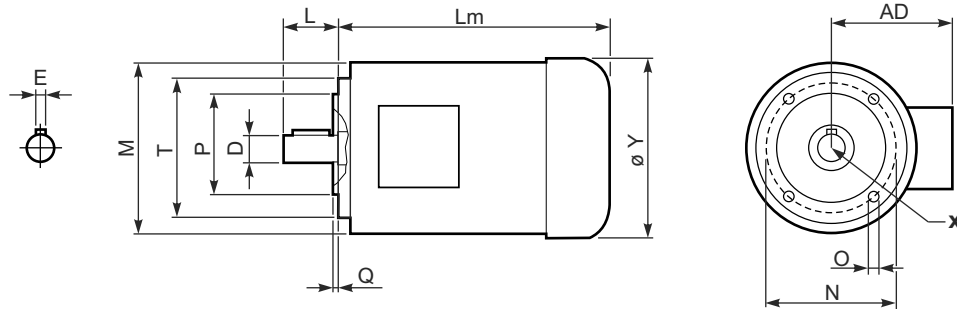

Outside dimensions may be different according to manufacturers.

Le dimensioni esterne sono indicative, possono variare tra i vari costruttori.

	4 poli / poles			D	E	L	Lm	Y	AD	P	N	M	T	O	Q	X	Kg
	kW	Nm	A _(400V)														
63	0.18	1.30	0.69	11	4	23.5	252	128	106	60	75	114	90	M5	2.5	-	8.2
71	0.25	1.70	0.91	14	5	30.5	228	146	115	70	85	134	105	M6	2.5	M5x20	8.3
	0.37	2.52	1.14				252										10.4
80	0.55	3.77	1.51	19	6	40	300	158	115	80	100	144	120	M6	3	M6x25	17.5
	0.75	5.11	2.57				367										
90	1.1	7.45	2.78	24	8	50	321	174	135	95	115	165	140	M8	3	M8x25	22.4
	1.5	10.2	3.61				367										27.6
100	2.2	14.8	5.07	28	8	60	374	203	150	110	130	190	160	M8	3.5	M10x25	33.5

Tecnical data
- Voltage: 230 / 400V
- Phase: 3
- Frequency: 50Hz
- Poles: 4
- International protections : IP 65
- Insulation class: F
- Duty: S1

Please Read Carefully

The following WARNING and CAUTION information is supplied to you for your protection and to provide you with many years of trouble free and safe operation of your product.

Read ALL instructions prior to operating reducer. Injury to personnel or reducer failure may be caused by improper installation, maintenance or operation.

WARNING:

- Written authorization is required to operate or use reducers in man lift or people moving devices.
- Check to make sure that certain applications do not exceed the allowable load capacities published in the current catalog.
- Buyer shall be solely responsible for determining the adequacy of the product for any and all uses to which Buyer shall apply the product. The application by Buyer shall not be subject to any implied warranty of fitness for a particular purpose.
- For safety, Buyer or User should provide protective guards over all shaft extensions and any moving apparatus mounted thereon. The User is responsible for checking all applicable safety codes in his area and providing suitable guards. Failure to do so may result in bodily injury and/or damage to equipment.
- Hot oil and reducers can cause severe burns. Use extreme care when removing lubrication plugs and vents.
- Make certain that the power supply is disconnected before attempting to service or remove any components. Lock out the power supply and tag it to prevent unexpected application power.
- Reducers are not to be considered fail safe or self-locking devices. If these features are required, a properly sized, independent holding device should be utilized. Reducers should not be used as a brake.
- Any brakes that are used in conjunction with a reducer must be sized or positioned in such a way so as to not subject the reducer to loads beyond the catalog rating.
- Lifting supports including eyebolts are to be used for vertically lifting the gearbox only and not other associated attachments or motors.
- Use of an oil with an EP additive on units with backstops may prevent proper operation of the backstop. Injury to personnel, damage to the reducer or other equipment may result.
- Overhung loads subject shaft bearings and shafts to stress which may cause premature bearing failure and or shaft breakage from bending fatigue, if not sized properly.

SELLING CONDITIONS

Warranty for manufacturing defects will expire one-year the invoicing date. Hydro-Mec will replace or repair defective parts but will not accept any further changes for direct or indirect damages of any kind. The warranty will become null and void if repairs or changes are carried out without our prior written authorization.

Our company will not be responsible for any direct or indirect damages, caused by a wrong use of the products or for not observing the catalogue/web indication

Leggere attentamente

Le seguenti raccomandazioni sono fondamentali per la vostra protezione e per garantirvi molti anni di sicuro funzionamento del vostro prodotto senza alcun problema.

Leggere attentamente tutte le istruzioni prima di azionare il riduttore. L'inappropriata installazione, manutenzione o funzionamento del riduttore può causare incidenti al personale addetto e danni al riduttore stesso.

ATTENZIONE!

- E' richiesta autorizzazione scritta per azionare riduttori in ascensori o dispositivi per il movimento delle persone.
- Controllare che alcune applicazioni non eccedano la massima capacità di carico ammessa pubblicata in questo catalogo.
- L'acquirente è l'unico responsabile per la determinazione dell'adeguatezza del prodotto per qualcuna o tutte le utilizzazioni che l'acquirente stesso farà del riduttore. L'applicazione dell'acquirente non potrà essere soggetta ad alcuna implicita garanzia di montaggio per uno scopo particolare.
- Per ragioni di sicurezza l'acquirente dovrà provvedere a porre protezioni adeguate su tutta la lunghezza dell'albero a tutti gli organi in movimento. L'utilizzatore è responsabile del controllo di tutti i codici di sicurezza e la predisposizione di protezioni adeguate. In assenza di tali precauzioni si possono verificare incidenti alle persone e danni agli apparati.
- Olio e riduttori bollenti possono causare gravi ustioni. Usare estrema cautela nella rimozione dei tappi e delle ventole.
- Assicurarsi che la corrente di alimentazione sia scollegata prima di riparare o rimuovere alcun componente. Chiudere l'alimentazione e contrassegnare tale operazione per evitare accensioni accidentali.
- I riduttori non devono essere considerati esenti da guasti o a bloccaggio automatico. Se sono indispensabili queste caratteristiche, deve essere utilizzato un dispositivo indipendente della dimensione adatta. I riduttori non devono essere utilizzati come freni.
- Qualsiasi freno sia utilizzato insieme al riduttore deve essere della giusta grandezza e posizionato in modo da non causare carichi eccessivi non previsti dai dati forniti nel catalogo.
- I dispositivi di sollevamento come le golfare devono essere usati solo per sollevare verticalmente il riduttore e non altri dispositivi associati o motori.
- L'utilizzo di un olio con un additivo EP su gruppi provvisti di dispositivo di arresto possono inficiare l'uso corretto del freno e provocare danni alle persone, alle cose ed al riduttore stesso nonché ad altri apparecchi.
- I Carichi sospesi assoggettano i cuscinetti della vite e la vite stessa a sollecitazioni che possono causare, se non adeguatamente dimensionati, l'usura prematura dei cuscinetti e/o la rottura della vite a causa della resistenza alla flessione.

CONDIZIONI DI VENDITA

La garanzia relativa a difetti di costruzione ha la durata di un anno dalla data di fatturazione della merce. Tale garanzia comporta per Hydro-mec l'onere della sostituzione o riparazione delle parti difettose ma non ammette ulteriori addebiti per eventuali danni diretti o indiretti di qualsiasi natura.

La garanzia decade nel caso in cui siano state eseguite riparazioni o apportate modifiche senza nostro consenso scritto.

La nostra ditta non si ritiene responsabile per eventuali danni diretti o indiretti derivanti da un uso improprio dei prodotti e dalla mancata osservanza delle indicazioni riportate a catalogo o web..

HYDRO-MEC

www.hydromec.com

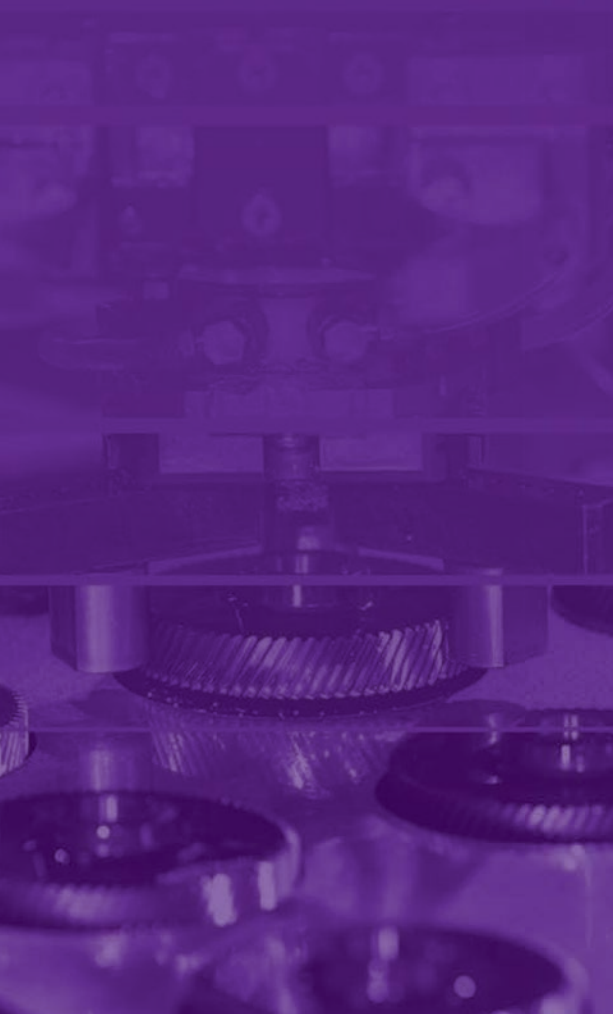

Distributed from



CT - GEM - A - HM0 1 4