

## Produktinformation PI 03

### *Product information PI 03*

#### **Werkzeughalter**

Mit Prismenaufnahme  
gem. DIN 69881

#### ***Toolholders***

*With dovetail mounting system  
acc. to DIN 69881*

2012-03-14

#### **HINWEIS:**

Die in dieser Produktinformation enthaltenen Informationen beruhen auf den zum Zeitpunkt der Drucklegung vorhandenen Erkenntnissen. Änderungen, die sich im Rahmen der ständigen Weiterentwicklung ergeben, behalten wir uns ausdrücklich vor.

*The information contained in this Product Information is in conformity with the knowledge at the point of printing. Subject to modification which occur within the framework of continuous further development.*

Hierzu Preisliste P 20  
see price list P 20





**Inhaltsverzeichnis**

*Table of contents*

	Form /Typ	Seite
	<i>form/type</i>	<i>page</i>
Werkzeughalter Queraufnahme . . . . . <i>Turning Toolholder DIN 69 881</i>	A2/A1 . . . . .	5
Werkzeughalter Längsaufnahme DIN 69 881 . . . . . <i>Turning Toolholder for Square Tool DIN 69 881</i>	A2/A1 . . . . .	6
Werkzeughalter-Mehrfachaufnahme DIN 69 881 . . . . . <i>Multi Purpose Square Toolholder DIN 69 881</i>	C2/C1 . . . . .	7
Werkzeughalter-Mehrfachaufnahme DIN 69 881 . . . . . <i>Multi Purpose Square Toolholder DIN 69 881</i>	C3 . . . . .	8
Werkzeughalter-Doppel-Radialaufnahme DIN 69 881 . . . . . <i>Multi Purpose Square Toolholder DIN 69 881</i>	. . . . .	8
Werkzeughalter-Zylinderaufnahme DIN 69 881 . . . . . <i>Side Lock Adaptor DIN 69 881D39</i>	D3 . . . . .	9
Werkzeughalter-Zylinderaufnahme DIN 69 881 . . . . . <i>Side Lock Adaptor DIN 69 881</i>	D2/D1 . . . . .	10
Bohrstangenhalter DIN 69 881 . . . . . <i>Boring Bar Holder DIN 69 881</i>	. . . . .	11
Kühlmittelverteiler DIN 69 881 . . . . . <i>Coolant Distributor DIN 69 881</i>	. . . . .	11
Mehrfach-Werkzeughalter DIN 69 881 . . . . . <i>Multi-Toolholder DIN 69 881</i>	. . . . .	12
Doppel-Bohrstangenhalter DIN 69 881 . . . . . <i>Double-Boring-Bar-Holder DIN 69 881</i>	. . . . .	12
Werkzeughalterplatte DIN 69 881 . . . . . <i>Toolholder Plate DIN 69 88113</i>	. . . . .	13
Bohrhalter für Wendeplattenbohrer DIN 69 881 . . . . . <i>Boring Holder for Carbide Tip Boring DIN 69 881</i>	. . . . .	14
Aufnahmhülse . . . . . <i>Adaptor Sleeve</i>	. . . . .	16
Aufnahmhülse geschlitzt . . . . . <i>Adaptor Sleeve split</i>	. . . . .	18
Bohrhalter . . . . . <i>Morsetaper Sleeve</i>	. . . . .	19
Spannzangenfutter mit Zylinderschaft . . . . . <i>Collet Chuck with cylindrical shaft</i>	. . . . .	20
Reduzierhülsen DIN 2185 . . . . . <i>Reducer Sleeve DIN 2185</i>	. . . . .	21



Werkzeughalter Queraufnahme DIN 69 881 Teil 2 Form A  
Turning Toolholder DIN 69 881 Part 2 Form A

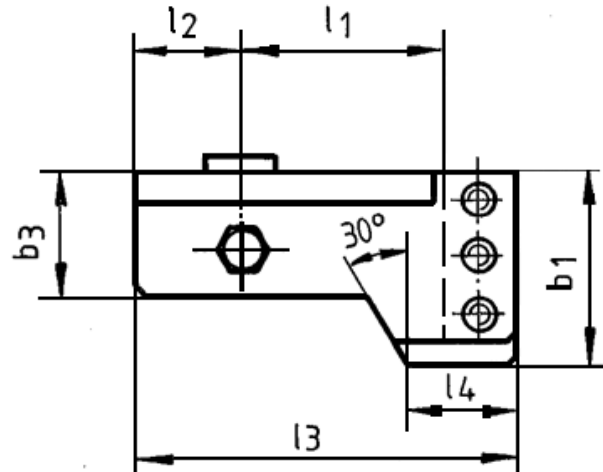
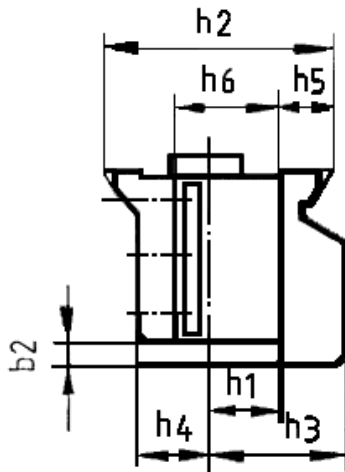

Form A2 Ausführung rechts (wie gezeichnet)

A2 Right side (as drawn)

Bezeichnung <i>Designation</i>	Ident-Nr. <i>Ident-No</i>	$h_2$	$h_1$	$b_1$	$b_2$	$b_3$	$h_3$	$h_4$	$h_5$	$h_6$	$l_1$	$l_2$	$l_3$	$l_4$
A2 – 56 x 16	118920	56	16	50	6	32	40	19	12	22	49	31	94	34
A2 – 72 x 20	118922	72	20	63	6	40	43	27	16	29	49	39	110	45
A2 – 90 x 25	118924	90	25	72	9	40	50	35,5	20	34	73	39	138	45
A2 – 115 x 32	118926	115	32	85	9	50	60	40	25,5	41	112	49	191	50
A2 – 140 x 40	118928	140	40	110	12	60	78	57,5	30	53	115	59	209	55

Form A1 Ausführung links (spiegelbildlich)

A1 Left side (mirror image)

Bezeichnung <i>Designation</i>	Ident-Nr. <i>Ident-No</i>	$h_2$	$h_1$	$b_1$	$b_2$	$b_3$	$h_3$	$h_4$	$h_5$	$h_6$	$l_1$	$l_2$	$l_3$	$l_4$
A1 – 56 x 16	118921	56	16	50	6	32	40	19	12	22	49	31	94	34
A1 – 72 x 20	118923	72	20	63	6	40	43	27	16	29	49	39	110	45
A1 – 90 x 25	118925	90	25	72	9	40	50	35,5	20	34	73	39	138	45
A1 – 115 x 32	118927	115	32	85	9	50	60	40	25,5	41	112	49	191	50
A1 – 140 x 40	118929	140	40	110	12	60	78	57,5	30	53	115	59	209	55

Werkzeughalter Längsaufnahme DIN 69 881 Teil 3 Form B  
Turning Toolholder for Square Tool DIN 69 881 Part 3 Form B

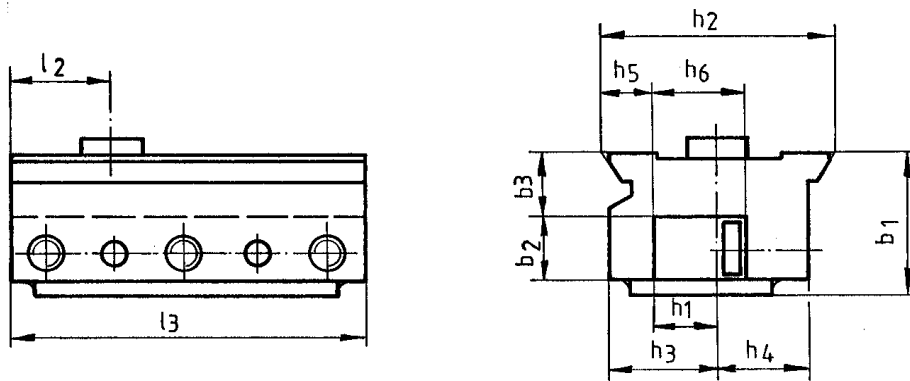

Form B2 Ausführung links (wie gezeichnet)      B2 Left side (as drawn)

Bezeichnung <i>Designation</i>	Ident-Nr. <i>Ident-No</i>	$h_2$	$h_1$	$b_1$	$b_2$	$b_3$ +0,5	$h_3$	$h_4$	$h_5$ $\pm 0,05$ max	$h_6$	$l_2$	$l_3$
B2 – 56 x 16	118912	56	16	39	20	16	26	19	12	22	31	94
B2 – 72 x 20	118914	72	20	47	26	16	34	27	16	29	39	110
B2 – 90 x 25	118916	90	25	49	26	18	42,5	35,5	20	34	39	118
B2 – 115 x 32	118918	115	32	56	33	18	55	40	25,5	41	49	123
B2 – 140 x 40	118919	140	40	67	42	20	67,5	57,5	30	53	59	160

Form B1 Ausführung rechts (spiegelbildlich)      B1 Right side (mirror image)

Bezeichnung <i>Designation</i>	Ident-Nr. <i>Ident-No</i>	$h_2$	$h_1$	$b_1$	$b_2$	$b_3$ +0,5	$h_3$	$h_4$	$h_5$ $\pm 0,05$ max	$h_6$	$l_2$	$l_3$
B1 – 56 x 16	118911	56	16	39	20	16	26	19	12	22	31	94
B1 – 72 x 20	118913	72	20	47	26	16	34	27	16	29	39	110
B1 – 90 x 25	118915	90	25	49	26	18	42,5	35,5	20	34	39	118
B1 – 115 x 32	118917	115	32	56	33	18	55	40	25,5	41	49	123
B1 – 140 x 40	118930	140	40	67	42	20	67,5	57,5	30	53	59	160

Werkzeughalter-Mehrfachaufnahme DIN 69 881 Teil 4 Form C  
Multi Purpose Square Toolholder DIN 69 881 Part 4 Form C

Ausführung A  
Design A

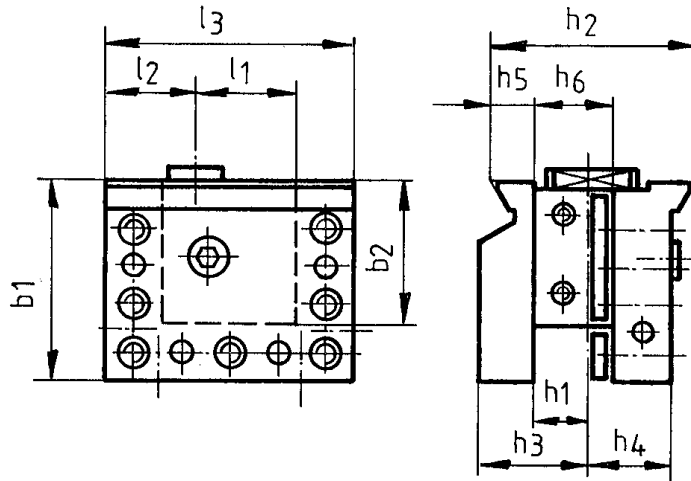

Form C2 Ausführung links (wie gezeichnet) C2 Left side (as drawn)

Bezeichnung Designation	Ident-Nr. Ident-No	$h_2$	$h_1$	$b_1$	$b_2$ +0,5	$h_3$	$h_4$	$h_5$ $\pm 0,05$ max	$h_6$	$l_1$ +0,5	$l_2$	$l_3$
C2 – 56 x 16	118897	56	16	60	46	40	19	12	22	39	31	84
C2 – 72 x 20	118899	72	20	81	59	43	27	16	29	37	39	98
C2 – 90 x 25	118901	90	25	88	62	50	35,5	20	34	43	39	108
C2 – 115 x 32	118903	115	32	94	68	60	40	25,5	41	43	49	118
C2 – 140 x 40	118905	140	40	115	83	78	57,5	30	53	53	59	144

Form C1 Ausführung rechts (spiegelbildlich) C1 Right side (mirror image)

Bezeichnung Designation	Ident-Nr. Ident-No	$h_2$	$h_1$	$b_1$	$b_2$ +0,5	$h_3$	$h_4$	$h_5$ $\pm 0,05$ max	$h_6$	$l_1$ +0,5	$l_2$	$l_3$
C1 – 56 x 16	118896	56	16	60	46	40	19	12	22	39	31	84
C1 – 72 x 20	118898	72	20	81	59	43	27	16	29	37	39	98
C1 – 90 x 25	118900	90	25	88	62	50	35,5	20	34	43	39	108
C1 – 115 x 32	118902	115	32	94	68	60	40	25,5	41	43	49	118
C1 – 140 x 40	118904	140	40	115	83	78	57,5	30	53	53	59	144

Werkzeughalter-Mehrfachaufnahme DIN 69 881 Teil 4 Form C3  
 Multi Purpose Square Toolholder DIN 69 881 Part 4 Form C3

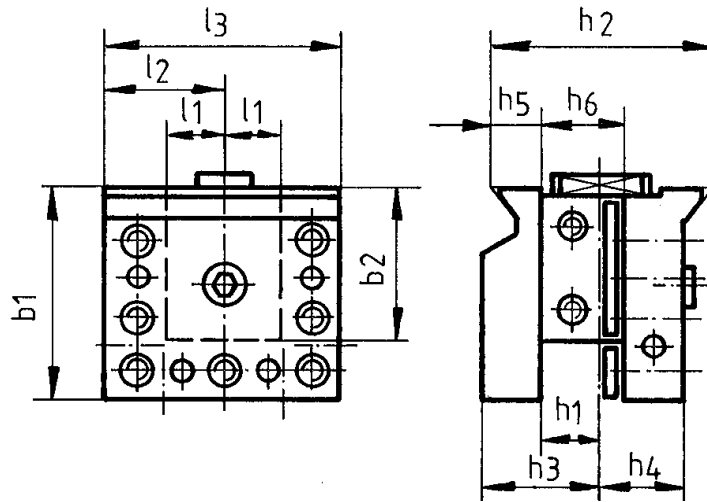

Bezeichnung	Ident-Nr.	$h_2$	$h_1$	$b_1$	$b_2$	$h_3$	$h_4$	$h_5$	$h_6$	$l_1$	$l_2$	$l_3$
Designation	Ident-No				+0,5			$\pm 0,05$ max		+0,5		
C3 – 56 x 16	118906	56	16	60	46	40	19	12	22	17	31	62
C3 – 72 x 20	118907	72	20	81	59	43	27	16	29	17	39	78
C3 – 90 x 25	118908	90	25	88	62	50	35,5	20	34	23	49	98
C3 – 115 x 32	118909	115	32	94	68	60	40	25,5	41	23	49	98
C3 – 140 x 40	118910	140	40	115	83	78	57,5	30	53	27	59	118

Werkzeughalter-Doppel-Radialaufnahme DIN 69 881  
 Double-Radial Square Toolholder DIN 69 881

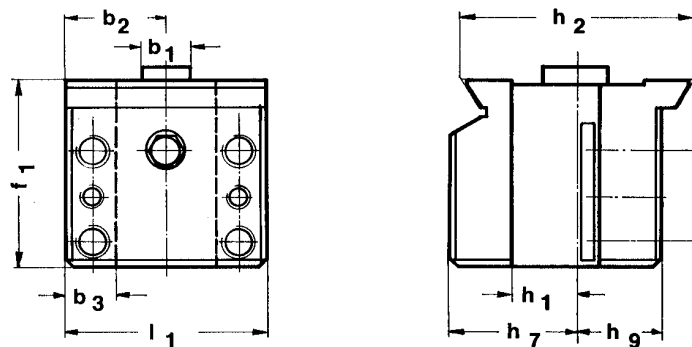

Ident-Nr.	$h_2$	$h_1$	$b_1$	$b_2$	$b_3$	$h_7$	$h_9$	$f_1$	$L_1$
Ident-No									
118971	56	16	16	34	16	40	19	60	68
118972	72	20	20	39	25	50	35,5	88	78
118973	90	25	25	39	25	50	35,5	88	78
118974	115	32	25	49	26	60	40	94	98
118975	140	40	25	59	32	78	57,5	115	118



Werkzeughalter-Zylinderaufnahme DIN 69 881 Teil 5 Form D3  
Side Lock Adaptor DIN 69 881 Part 5 Form D3

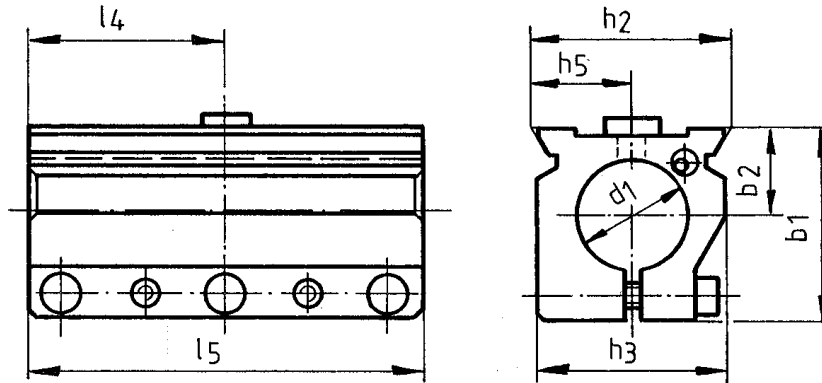

Bezeichnung <i>Designation</i>	Ident-Nr. <i>Ident-No</i>	NG <i>Size</i>	$h_2$	$d_1$ H7	$b_1$	$b_2$	$h_3$	$h_5$	$l_4$	$l_5$
D3 – 56 x 32	118866	16	56	32	65	30	52	28	59	118
D3 – 72 x 40	118867	20	72	40	76	35	68	36	75	150
D3 – 90 x 50	118868	25	90	50	94	45	85	45	99	198
D3 – 115 x 60	118869	32	115	60	94	45	93	57,5	99	198
D3 – 140 x 80	118870	40	140	80	125	60	115	70	119	238

Bezeichnung <i>Designation</i>	Ident-Nr. <i>Ident-No</i>	NG <i>Size</i>	$h_2$	$d_1$ H7	$b_1$	$b_2$	$h_3$	$h_5$	$l_4$	$l_5$
D3 – 56 x 40	118871	16	56	40	65	30	52	28	59	118
D3 – 72 x 50	118872	20	72	50	76	35	68	36	75	150
D3 – 90 x 60	118873	25	90	60	94	45	85	45	99	198
D3 – 115 x 80	118874	32	115	80	115	55	115	57,5	99	198
D3 – 140 x 100	118875	40	140	100	145	70	135	70	119	238

Werkzeughalter-Zylinderaufnahme DIN 69 881 Teil 5 Form D  
Side Lock Adaptor DIN 69 881 Part 5 Form D

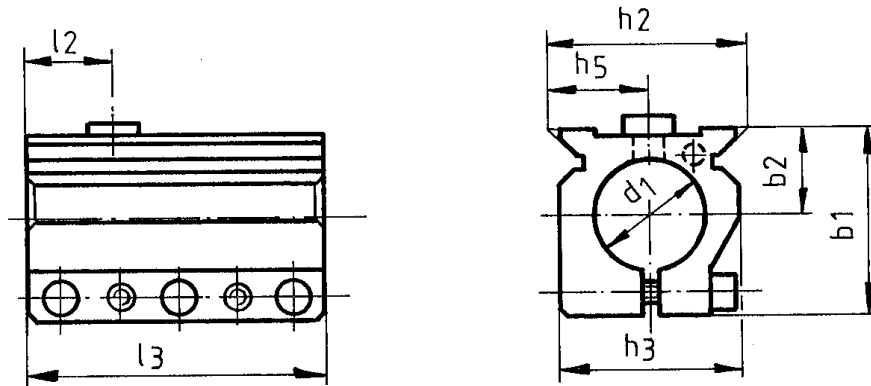

Form D2 Ausführung rechts (wie gezeichnet) D2 Right side (as drawn )

Bezeichnung <i>Designation</i>	Ident-Nr. <i>Ident-No</i>	NG <i>Size</i>	$h_2$	$d_1$ H7	$b_1$	$b_2$	$h_3$	$h_5$	$l_2$	$l_3$
D2 – 56 x 32	118876	16	56	32	65	30	52	28	31	94
D2 – 72 x 40	118878	20	72	40	76	35	68	36	39	110
D2 – 90 x 50	118880	25	90	50	94	45	85	45	39	138
D2 – 115 x 60	118882	32	115	60	115	45	93	57,5	49	148
D2 – 140 x 80	118884	40	140	80	125	60	115	70	59	178

Form D1 Ausführung links (spiegelbildlich) D1 Left side (mirror image)

Bezeichnung <i>Designation</i>	Ident-Nr. <i>Ident-No</i>	NG <i>Size</i>	$h_2$	$d_1$ H7	$b_1$	$b_2$	$h_3$	$h_5$	$l_2$	$l_3$
D1 – 56 x 32	118877	16	56	32	65	30	52	28	31	94
D1 – 72 x 40	118879	20	72	40	76	35	68	36	39	110
D1 – 90 x 50	118881	25	90	50	94	45	85	45	39	138
D1 – 115 x 60	118883	32	115	60	115	45	93	57,5	49	148
D1 – 140 x 80	118885	40	140	80	125	60	115	70	59	178

Form D2 Ausführung rechts (wie gezeichnet) D2 Right side (as drawn )

Bezeichnung <i>Designation</i>	Ident-Nr. <i>Ident-No</i>	NG <i>Size</i>	$h_2$	$d_1$ H7	$b_1$	$b_2$	$h_3$	$h_5$	$l_2$	$l_3$
D2 – 56 x 40	118886	16	56	40	65	30	52	28	31	94
D2 – 72 x 50	118888	20	72	50	76	35	68	36	39	110
D2 – 90 x 60	118890	25	90	60	94	45	85	45	39	138
D2 – 115 x 80	118892	32	115	80	115	55	115	57,5	49	148
D2 – 140 x 100	118894	40	140	100	125	70	135	70	59	178

Form D1 Ausführung links (spiegelbildlich) D1 Left side (mirror image)

Bezeichnung <i>Designation</i>	Ident-Nr. <i>Ident-No</i>	NG <i>Size</i>	$h_2$	$d_1$ H7	$b_1$	$b_2$	$h_3$	$h_5$	$l_2$	$l_3$
D1 – 56 x 40	118887	16	56	40	65	30	52	28	31	94
D1 – 72 x 50	118889	20	72	50	76	35	68	36	39	110
D1 – 90 x 60	118891	25	90	60	94	45	85	45	39	138
D1 – 115 x 80	118893	32	115	80	115	55	115	57,5	49	148
D1 – 140 x 100	118895	40	140	100	125	70	135	70	59	178

**Bohrstangenhalter- DIN 69 881**  
*Boring Bar Holder DIN 69 881*

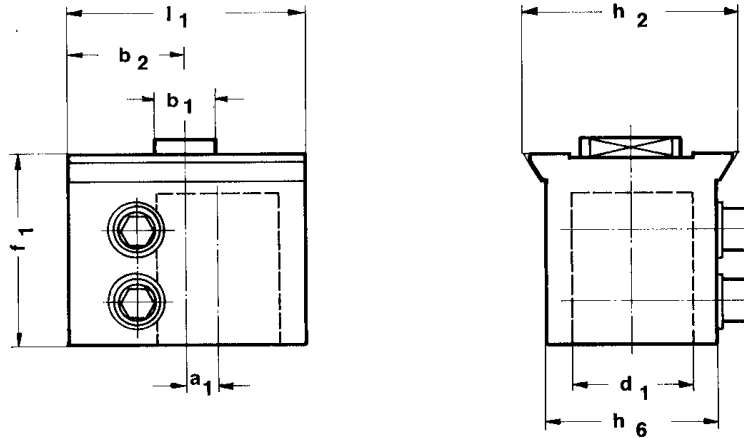

Nenngröße Size	Ident-Nr. Ident-No	d <sub>1</sub>	a <sub>1</sub>	b <sub>1</sub>	b <sub>2</sub>	h <sub>2</sub>	h <sub>6</sub>	f <sub>1</sub>	l <sub>1</sub>
16	118976	32	8	16	34	56	39	54	68
20	118977	40	10	20	39	72	53	65	78
25	118978	50		25	59	90	71	80	98
32	118979	60	12,5	25	49	115	95	94	98
40	118980	80	12,5	25	59	140	115	120	118

**Kühlmittelverteiler DIN 69 881**  
*Coolant Distributor DIN 69 881*

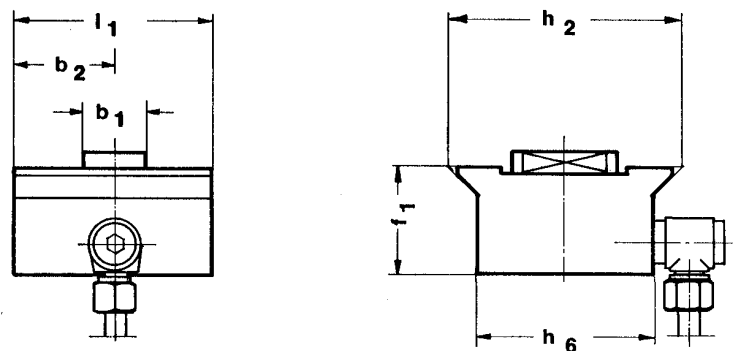

Nenngröße Size	Ident-Nr. Ident-No	b <sub>1</sub>	b <sub>2</sub>	h <sub>2</sub>	h <sub>6</sub>	f <sub>1</sub>	l <sub>1</sub>
16	118981	16	34	56	39	28	68
20	118982	20	39	72	53	34	78
25	118983	25	39	90	71	42	78
32	118984	25	49	115	95	54	98
40	118985	25	59	140	115	60	118

Mehrfach-Werkzeughalter DIN 69 881  
Multi-Toolholder DIN 69 881

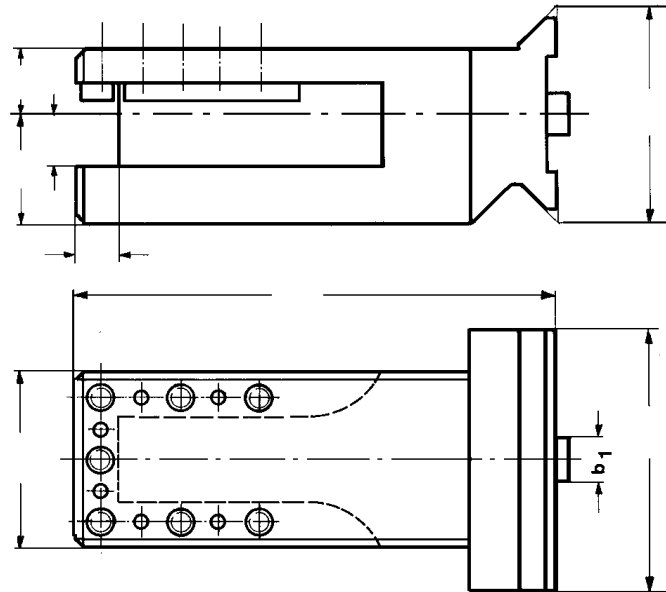

Nenngröße Size	Ident-Nr. Ident-No	$h_1$	$h_2$	$h_7$	$h_9$	$b_1$	$f_1$	$f_2$	$l_1$	$l_2$
16	119032	16	56	40	19	16	160	15	62	55
20	119033	20	72	42,5	26	20	180	18	82	70
25	119034	25	90	50	30	25	200	22	78	78
32	119035	32	115	60	40	25	220	28	118	98
40	119036	40	140	80	57	25	240	32	155	118

Doppel-Bohrstangenhalter DIN 69 881  
Double-Boring Bar Holder DIN 69 881

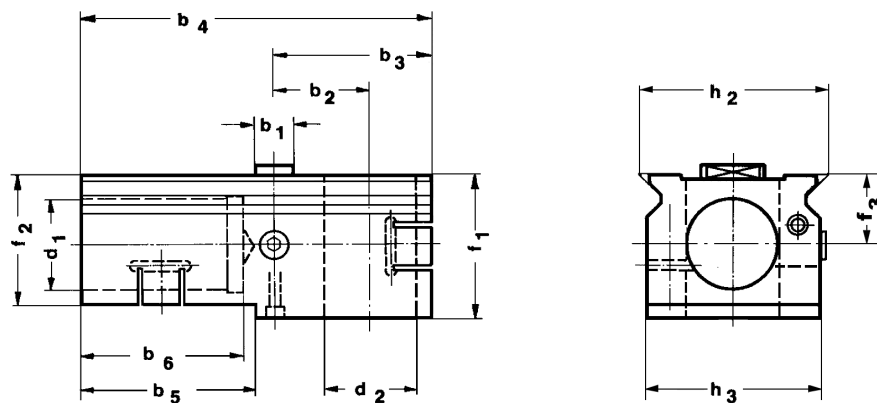

Nenngröße Size	Ident-Nr. Ident-No	$h_2$	$d_1$	$d_2$	$h_3$	$b_1$	$b_2$	$b_3$	$b_4$	$b_5$	$b_6$	$f_1$	$f_2$	$f_3$
20	119037	72	40	40	68	20	40	75	175	-	80	70	70	35
25	119038	90	50	50	85	25	45	80	210	120	110	85	75	40
32	119039	115	60	60	110	25	62,5	102	227	150	125	94	85	45
40	119040	140	80	80	135	25	65	120	300	170	150	125	115	60

Werkzeughalterplatte DIN 69 881  
Toolholder Plate DIN 69 881

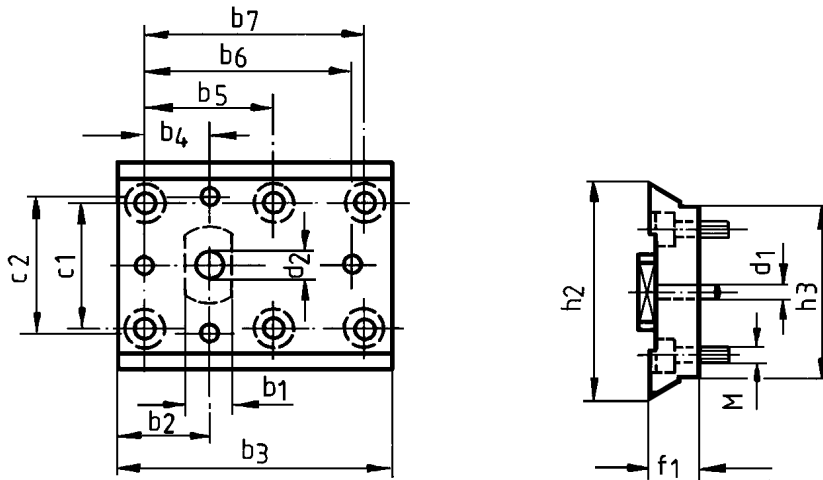

Lange Ausführung

Long version

Nenngröße Size	Ident-Nr. Ident-No	$h_2$	$h_3$	$b_1$	$b_2$	$b_3$	$b_4$	$b_5$	$b_6$	$b_7$	$c_1$	$c_2$	$f_1$	$m$	$d_1$	$d_2$
20	119041	72	53	20	39	98	25	-	-	70	30	40	20	M8	6	13
25	119042	90	71	25	39	115	25	50	87	87	55	55	55	M10	8	15
32	119043	115	95	25	49	148	35	70	115	120	70	70	25	M10	8	15
40	119044	140	115	25	59	200	45	90	172	172	90	90	35	M12	10	15

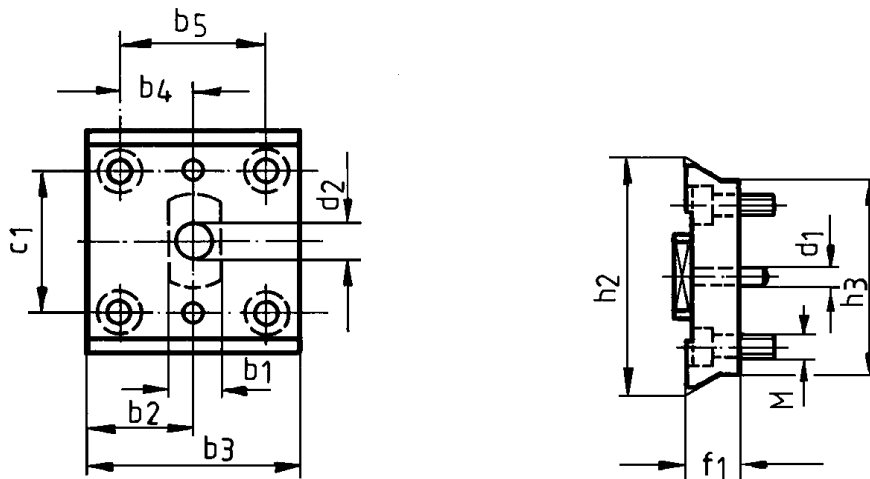

Kurze Ausführung

Short version

Nenngröße Size	Ident-Nr. Ident-No	$h_2$	$h_3$	$b_1$	$b_2$	$b_3$	$b_4$	$b_5$	$c_1$	$f_1$	$m$	$d_1$	$d_1$
20	119045	72	53	20	39	78	25	50	30	20	M8	6	13
25	119046	90	71	25	39	78	25	50	55	25	M10	8	15
32	119047	115	95	25	49	98	35	70	70	25	M10	8	15
40	119048	140	115	25	59	160	45	132	90	35	M12	10	15

Bohrhalter für Wendepplattenbohrer DIN 69 881  
 Boring Holder for Carbide Tip Boring DIN 69 881

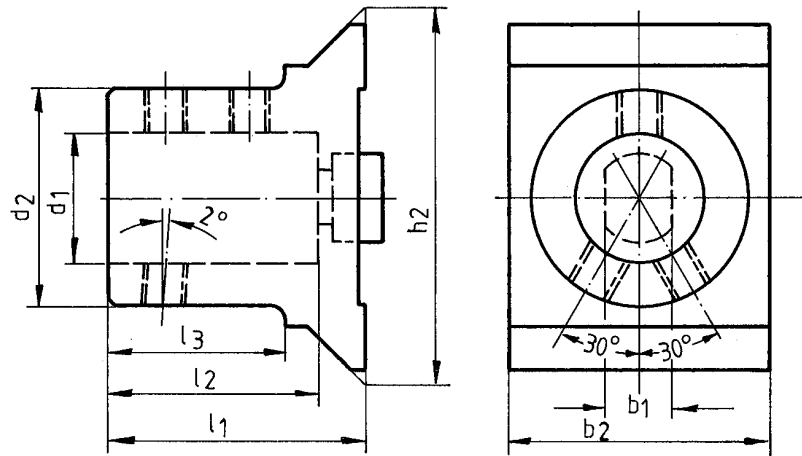

Nenngröße Size	Ident-Nr. Ident-No	h <sub>2</sub>	b <sub>1</sub>	b <sub>2</sub>	d <sub>1</sub>	d <sub>2</sub>	l <sub>1</sub>	l <sub>2</sub>	l <sub>3</sub>
16	119049	56	16	68	20	44	66	54	44
16	119050	56	16	68	25	49	71	59	49
16	119051	56	16	68	32	56	75	63	54
16	119052	56	16	68	40	64	85	73	60
20	119053	72	20	78	20	44	66	54	44
20	119054	72	20	78	25	49	71	59	49
20	119055	72	20	78	32	56	75	63	54
20	119056	72	20	78	40	64	85	73	60
20	119057	72	20	78	50	74	95	83	70
25	119058	90	25	98	20	44	66	54	44
25	119059	90	25	98	25	49	71	59	49
25	119060	90	25	98	32	56	75	63	54
25	119061	90	25	98	40	64	85	73	60
25	119062	90	25	98	50	74	95	83	70
32	119063	115	25	98	20	44	66	54	44
32	119064	115	25	98	25	49	71	59	49
32	119065	115	25	98	32	56	75	63	54
32	119066	115	25	98	40	64	85	73	60
32	119067	115	25	98	50	74	95	83	70
40	119068	140	25	118	20	44	66	54	44
40	119069	140	25	118	25	49	71	59	49
40	119070	140	25	118	32	56	75	63	54
40	119071	140	25	118	40	64	85	73	60
40	119072	140	25	118	50	74	95	83	70

Bohrhalter für Wendeplattenbohrer DIN 69 881  
 Boring Holder for Carbide Tip Boring DIN 69 881

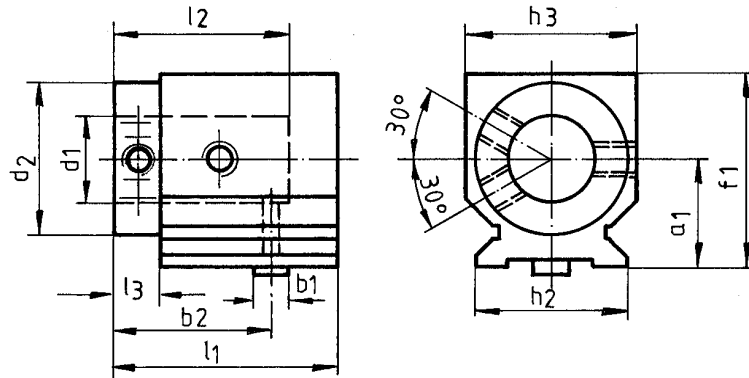

Nenngröße Size	Ident-Nr. Ident-No.	a <sub>1</sub>	b <sub>1</sub>	b <sub>2</sub>	d <sub>1</sub>	d <sub>2</sub>	f <sub>1</sub>	h <sub>2</sub>	h <sub>3</sub>	l <sub>1</sub>	l <sub>2</sub>	l <sub>3</sub>
16	119073	40	16	75	20	44	76	56	66	109	54	28
16	119074	40	16	75	25	49	76	56	66	109	59	28
16	119075	40	16	75	32	56	76	56	66	109	63	28
16	119076	40	16	75	40	64	76	56	66	109	73	32
20	119077	45	20	80	20	44	78	72	68	119	54	28
20	119078	45	20	80	25	49	78	72	68	119	59	28
20	119079	45	20	80	32	56	78	72	68	119	63	28
20	119080	45	20	80	40	64	78	72	68	119	73	32
20	119081	45	20	80	50	74	78	72	68	119	83	34
25	119082	50	25	100	20	44	86	90	80	139	54	28
25	119083	50	25	100	25	49	86	90	80	139	59	28
25	119084	50	25	100	32	56	86	90	80	139	63	28
25	119085	50	25	100	40	64	86	90	80	139	73	32
25	119086	50	25	100	50	74	86	90	80	139	83	34
32	119087	55	25	100	20	44	95	115	94	149	54	28
32	119088	55	25	100	25	49	95	115	94	149	59	28
32	119089	55	25	100	32	56	95	115	94	149	63	28
32	119090	55	25	100	40	64	95	115	94	149	73	32
32	119091	55	25	100	50	74	95	115	94	149	83	34
40	119092	60	25	120	20	44	100	140	114	189	54	28
40	119093	60	25	120	25	49	100	140	114	189	59	28
40	119094	60	25	120	32	56	100	140	114	189	63	28
40	119095	60	25	120	40	64	100	140	114	189	73	32
40	119096	60	25	120	50	74	100	140	114	189	83	34

Bohrhalter für Wendeplattenbohrer DIN 69 881  
 Boring Holder for Carbide Tip Boring DIN 69 881

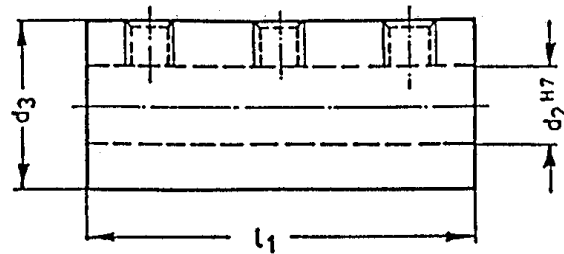

Ident-Nr. <i>Ident-No.</i>	$d_3$	$d_2$	$l_1$	Ident-Nr. <i>Ident-No.</i>	$d_3$	$d_2$	$l_1$
119002	32	10	60	120773	50	25	100
119003	32	12	60	120774	50	32	100
119004	32	15	60	120775	60	15	115
119005	32	16	60	120776	60	16	115
119006	32	20	60	120777	60	20	115
119007	40	10	80	120778	60	25	115
119008	40	12	80	120779	60	32	115
119009	40	15	80	120780	60	40	115
119010	40	16	80	120781	80	32	130
119011	40	20	80	120782	80	40	130
119012	40	25	80	120783	80	50	130
119013	50	10	100	120784	80	60	130
119014	50	12	100	120785	100	40	170
119015	50	15	100	120786	100	50	170
119016	50	16	100	120787	100	60	170
119017	50	20	100	120788	100	80	170

Aufnahmehülsen mit weiteren Maßen auf Anfrage  
*Adaptor Sleeve with other dimension on request*



Aufnahmhülse  
Adaptor Sleeve

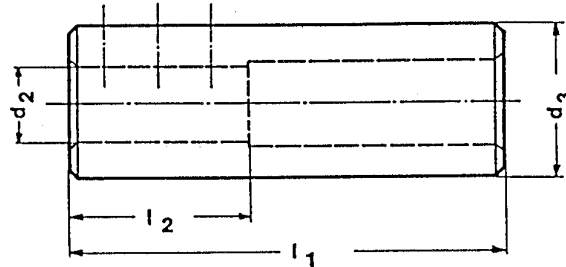

Ident-Nr. <i>Ident-No.</i>	$d_3$	$d_2$	$l_1$	$l_2$	Ident-Nr. <i>Ident-No.</i>	$d_3$	$d_2$	$l_1$	$l_2$
119018	32	10	110	40	120789	50	16	140	50
119019	32	12	110	40	120790	50	20	140	60
119020	32	15	110	50	120791	50	25	140	70
119021	32	16	110	50	120792	50	32	140	80
119022	32	20	110	60	120793	60	15	150	50
119023	40	10	130	40	120794	60	16	150	50
119024	40	12	130	40	120795	60	20	150	60
119025	40	15	130	50	120796	60	25	150	70
119026	40	16	130	50	120797	60	32	150	80
119027	40	20	130	60	120798	60	40	150	100
119028	40	25	130	70	120799	80	32	180	80
119029	50	10	140	40	120800	80	40	180	100
119030	50	12	140	40	120801	80	50	180	120
119031	50	15	140	50	120802	80	60	180	140

Aufnahmhülsen mit weiteren Maßen auf Anfrage  
*Adaptor Sleeve with other dimension on request*

Aufnahmehülse geschlitzt  
*Adaptor Sleeve split*

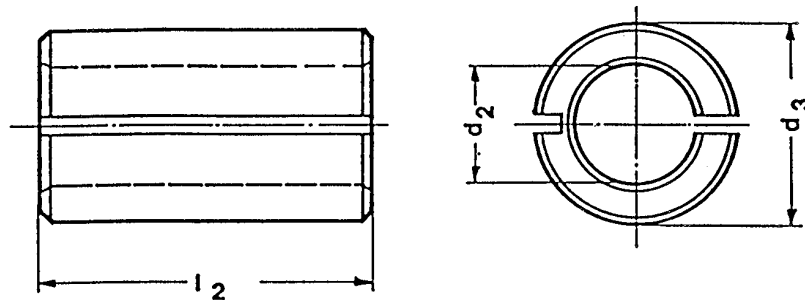

Ident-Nr. <i>Ident-No.</i>	d <sub>3</sub>	d <sub>2</sub>	l <sub>2</sub>	Ident-Nr. <i>Ident-No.</i>	d <sub>3</sub>	d <sub>2</sub>	l <sub>2</sub>
119114	32	8	65	120803	40	20	75
119115	32	10	65	120804	40	25	75
119116	32	12	65	120805	40	25,4	75
119117	32	12,7	65	120806	40	30	75
119118	32	14	65	120807	40	32	75
119119	32	15	65	120808	50	10	85
119120	32	16	65	120809	50	12	85
119121	32	18	65	120810	50	16	85
119122	32	19,05	65	120811	50	20	85
119123	32	20	65	120812	50	25	85
119124	32	25	65	120813	50	30	85
119125	32	25,4	65	120814	50	32	85
119126	40	8	75	120815	50	40	85
119127	40	10	75	120816	60	12	95
119128	40	12	75	120817	60	16	95
119129	40	12,7	75	120818	60	20	95
119130	40	14	75	120819	60	25	95
119131	40	15	75	120820	60	30	95
119132	40	16	75	120821	60	32	95
119133	40	18	75	120822	60	40	95
119134	40	19,05	75	120823	60	50	95

Aufnahmehülsen mit weiteren Maßen auf Anfrage  
*Adaptor Sleeve with other dimension on request*

Bohrhalter  
Boring holder

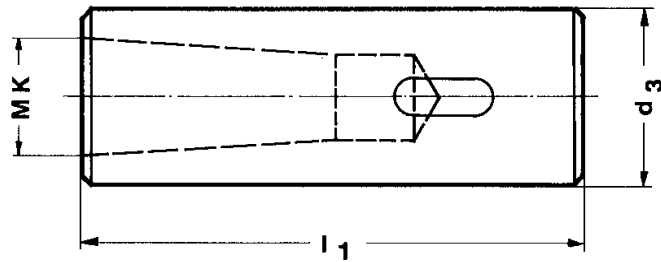

Ident-Nr. <i>Ident-No.</i>	d <sub>3</sub>	MK	l <sub>1</sub>	Ident-Nr. <i>Ident-No.</i>	d <sub>3</sub>	MK	l <sub>1</sub>
119135	32	1	92	120824	60	3	148
119136	32	2	92	120825	60	4	148
119137	32	3	92	120826	60	5	148
119138	40	1	92	120827	60	3	180
119139	40	2	92	120828	60	4	180
119140	40	3	92	120829	60	5	180
119141	40	4	115	120830	80	4	180
119142	50	2	115	120831	80	5	180
119143	50	3	115	120832	10	4	180
119144	50	4	115	120833	100	5	180

Bohrhalter mit weiteren Maßen auf Anfrage  
Boring holder with other dimension on request

Spannzangenfutter mit Zylinderschaft  
*Collet Chuck with cylindrical shaft*

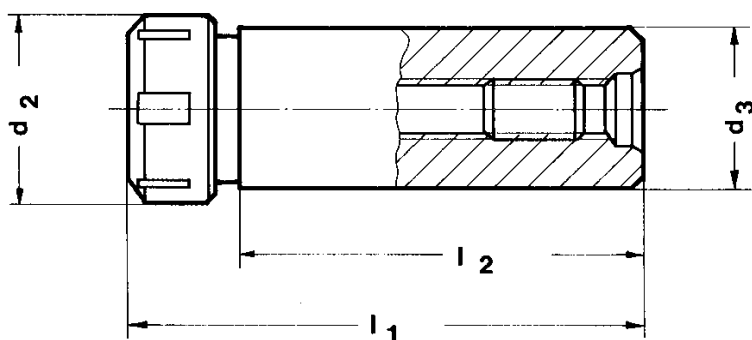

Spannbereich <i>Capacity</i>		Ident-Nr. <i>Ident-No.</i>	d <sub>2</sub>	d <sub>3</sub>	l <sub>1</sub>	l <sub>2</sub>	Spannzangen <i>collets</i>	Spannschlüssel <i>Key</i>
Satz <i>Set</i>	Zange <i>Collet</i>							
1 - 16	1	119145	42	32	120	80	250 430 E	225
1 - 16	1	119146	42	40	120	88	250 430 E	225
2 - 20	1	119147	50	32	142	90	320 470 E	232
2 - 20	1	119148	50	40	142	90	320 470 E	232
3 - 26	1	119608	63	40	160	100	400 472 E	240
3 - 26	1	119149	63	50	160	100	400 472 E	240

Bohrhalter mit weiteren Maßen auf Anfrage  
*Adaptor Sleeve with other dimension on request*

Reduzierhülsen DIN 2185  
Reducer Sleeve DIN 2185

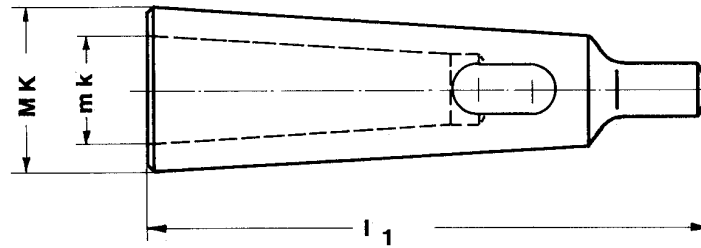

Nr. <i>No.</i>	Ident-Nr. <i>Ident-No.</i>	MK	d <sub>1</sub>	d <sub>3</sub>	Nr.	Ident-Nr. <i>Ident-No.</i>	MK	d <sub>1</sub>	d <sub>3</sub>
3002	119156	2	1	92	3005	120851	4	1	124
3003	119157	3	1	99	3006	120852	4	2	124
3004	119158	3	2	112	3007	120853	4	3	140