

Data sheet

Fan Systems

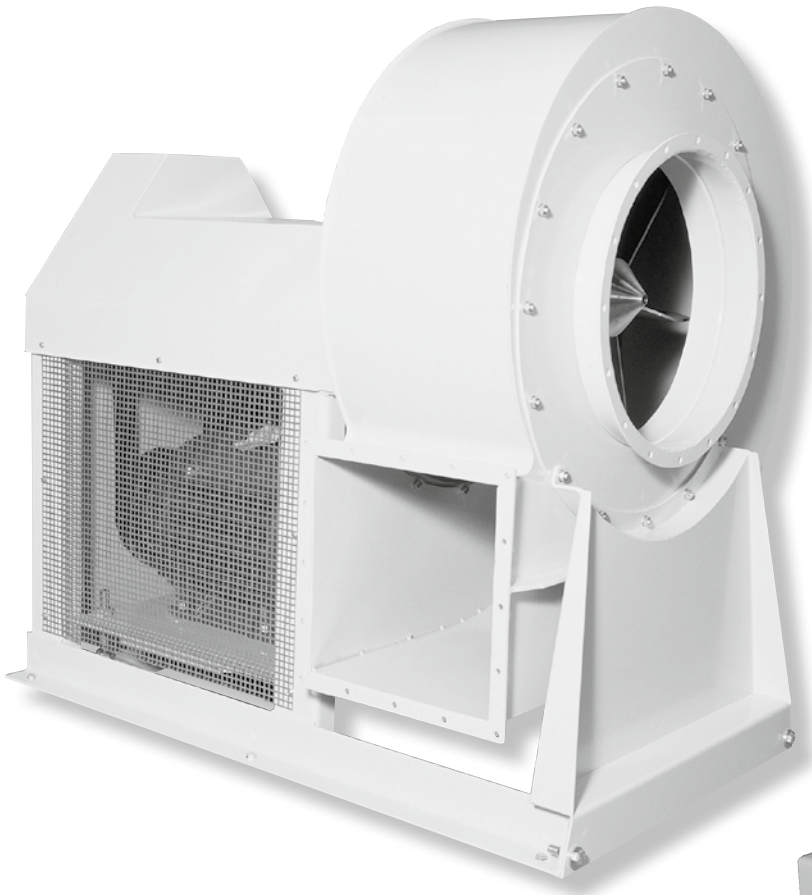

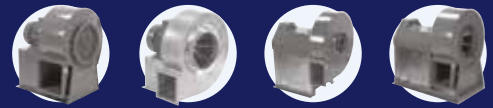

Table of contents

Section 00. General

Table of contents	Page 02
Fan types	Page 03
How to read fan graphs.....	Page 06

Section 01. Fan types MTD 20 – MTD 40

Fan types MTD 20 - MTD 40 general	Page 07
Fan type MTD 20.....	Page 08
Fan type MTD 22.....	Page 09
Fan type MTD 25.....	Page 10
Fan type MTD 30.....	Page 11
Fan type MTD 35.....	Page 12
Fan type MTD 40.....	Page 13

Section 02. Fan types MTK 40- MTK 75

Fan types MTK 40 - MTK 75 general	Page 14
Fan type MTK 40.....	Page 15
Fan type MTK 45.....	Page 16
Fan type MTK 55.....	Page 17
Fan type MTK 75.....	Page 18

Section 03. Fan type BTD/BPD/BTK/BPK

Fan type BTD/BPD/BTK/BPK general	Page 19
Fan type BTD/BPD/BTK/BPK 200.....	Page 20 - 21
Fan type BTD/BPD/BTK/BPK 300.....	Page 22 - 23
Fan type BTD/BPD/BTK/BPK 400.....	Page 24 - 25
Fan type BTD/BPD/BTK/BPK 500.....	Page 26 - 27

Section 04. Fan types MCD 30 - MCD 50

Fan types MCD 30 - 50 general	Page 28
Fan type MCD 30.....	Page 29
Fan type MCD 40.....	Page 30
Fan type MCD 50.....	Page 31

Section 05. Fan types MCK 40 - MCK 100

Fan types MCK 40 - MCK 100 general	Page 32
Fan type MCK 40.....	Page 33
Fan type MCK 50.....	Page 34
Fan type MCK 60.....	Page 35
Fan type MCK 70.....	Page 36
Fan type MCK 80.....	Page 37
Fan type MCK 90.....	Page 38
Fan type MCK 100.....	Page 39

Section 06. Accessories

Acoustic booths type AB.....	Page 40 - 41
------------------------------	--------------



Fan types

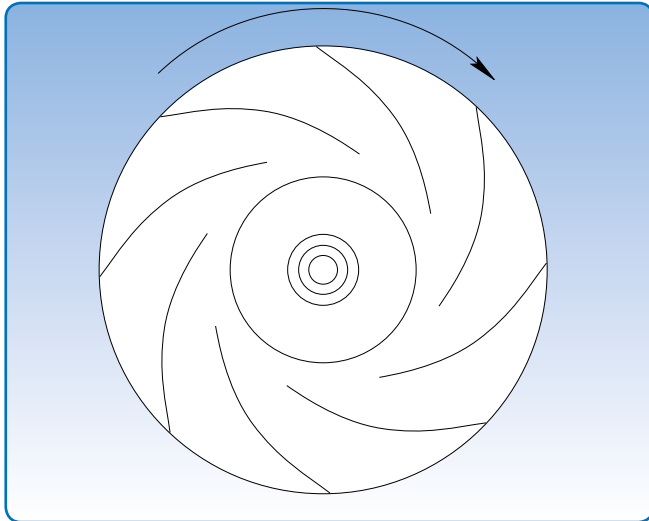

Radial fan with P-impeller

There are many types of fan impeller, each of which is designed for a given task:

- Radial fan with P-impeller
- Radial fan with T-impeller

Radial fan with P-impeller

Has flat backward-inclined blades and is designed for clean air transport. This type has the following properties:

- High efficiency
- Robust construction
- Only small variations in volume flow if resistance fluctuates.

Radial fan with T-impeller

Has backward-inclined blades and is designed for transport of a range of materials. This type has the following properties:

- Medium and high-pressure versions
- Robust construction
- High degree of self-cleaning
- Can handle large material volumes
- Special version available for transport of plastic and paper
- All fans are ATEX-certified in accordance with Directive 94/9 EF.

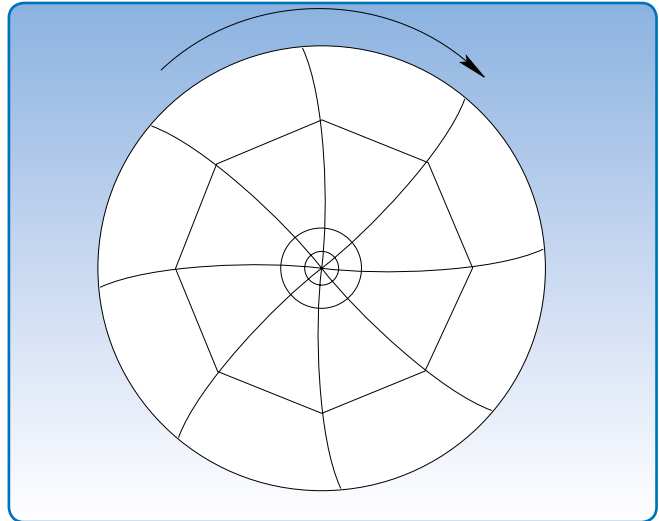

Radial fan with T-impeller

Temperatures

The graphs indicate 20°C. Fans can be used for temperatures up to 60°C without physical modification.

At temperatures other than 20°C, the air density is changed. This means it may be necessary to adjust the min^{-1} . At temperatures over 20°C the fan will generally be giving reduced effect in relation to the rise in temperature.

For high temperatures, the following should be taken into consideration: bearings and lubricant - whether the fan should be fitted with cooling wings - whether the motor should be supplied with extra cooling (particularly important for frequency regulation). For temperatures in excess of 60°C, extra cooling is required.

Fan types

Motors and fans are usually supplied as a unit. JKF has designed its fans for optimal performance, and it is vital to select the right one for any given task. The speed at which the fan is to run can be seen from the graph for that fan. The power input required depends on resistance in the system.

Blowers are delivered as standard in position RV (LG 270 according to Eurovent)



Fan types

Type MTD

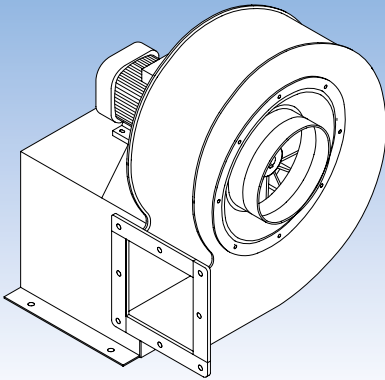

- Transport fan
- Direct drive
- Air volume from 750 to 11,000 m³/h
- Pressure: 110 – 440 mm WG

Page 7-13

Type MTK

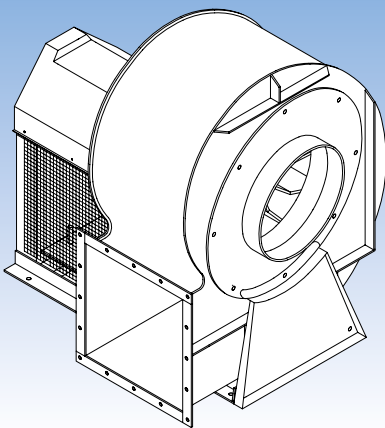

- Transport fan
- Indirect drive
- Air volume from 2,800 to 40,000 m³/h
- Pressure: 60 – 600 mm WG

Page 14-18

Type BTD/BTK - BPD/BPK

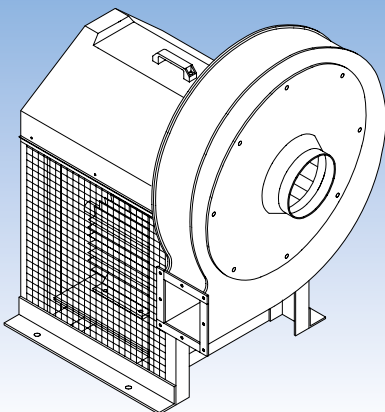

- Transport fan
- Indirect drive
- Air volume from 2,000 to 13,000 m³/h
- Pressure: 250 – 1,000 mm WG

Page 19-27



Fan types

Type MCD

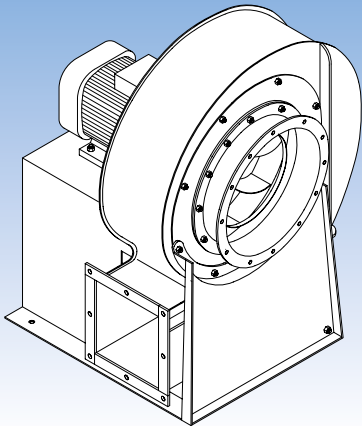

- Clean air fan
- Direct drive
- Air volume from 2,000 to 88,000 m³/h
- Pressure: 120 – 600 mm WG

Page 28-31

Type MCK

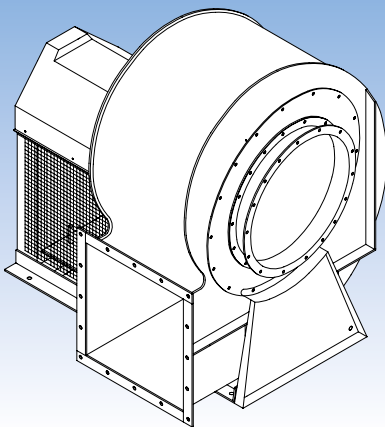

- Clean air fan
- Indirect drive
- Air volume from 2,500 to 115,000 m³/h
- Pressure: 80 – 600 mm WG

Page 32-39



How to read fan graphs

In practice it is highly likely that the operational point for a fan will not appear on the graphs referring to useful effect, but between them.

Determination of values for the operational point selected can be calculated using the following formulas:

Total useful effect

$$\eta_T = \frac{p \times Q \times 9,81}{1000 \times P}$$

p = Total pressure read from graph in mm WG

Q = Air volume read from graph in m³/h

P = Power input to electric motor in kW

When calculating useful effect

When only working with power input to the impeller, the following formulas can be used:

For *direct drive fans* the useful effect is

$$\eta_D = \eta_T + 10\%$$

For *indirect drive fans* the useful effect is

$$\eta_{ID} = \eta_T + 10\% + 6\%$$

For noise calculation

The following formulas can be used along with sound measurement apparatus:

min⁻¹ adjustment:

$$L_2 = L_1 + 60 \times \log \frac{n_2}{n_1}$$

L_1 = Noise level at min⁻¹ n_1

n_2 = New min⁻¹

Noise level at various distances:

$$L_{PA} = L_{WA} - (20 \times \log R) + (10 \times \log Q) - 11 \text{ dB(A)}$$

L_{WA} = Noise effect

R = Distance between noise source and receiver

Q = Direction factor

$Q = 2$ (hemispherical spread)

$Q = 4$ (quartspherical spread)

$Q = 8$ (octaspherical spread)

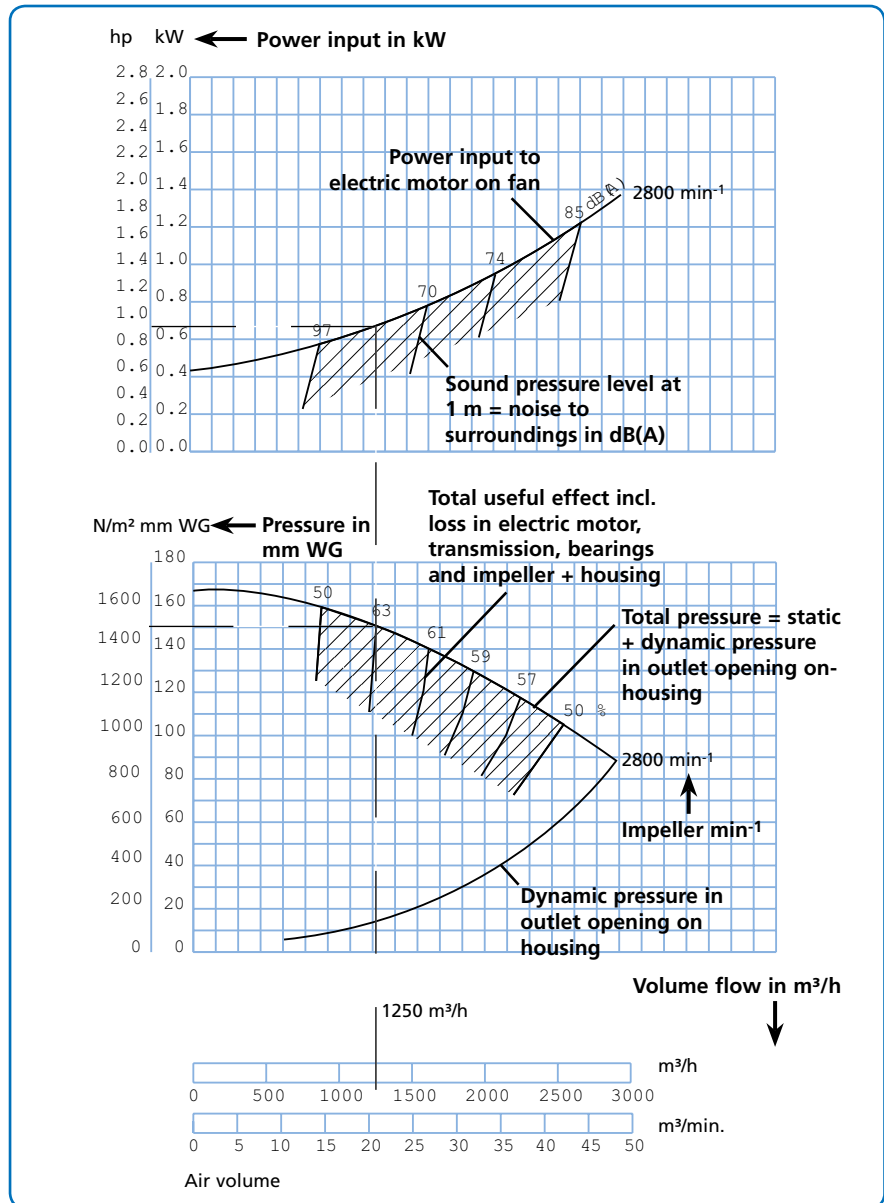

Example at 1250 m³/h

Read-off from graph for useful effect and pressure will show 150 mm WG and useful effect of 63%. The power input graph will show a read-off of 0.7 kW at 1250 m³/h.

Every effort should be made to set a fan up to achieve the best useful effect possible.



Fan types MTD 20 - MTD 40

The direct drive centrifugal fan types MTD 20 - MTD 40 are designed for material handling.

Equipped with self-cleaning impellers with backward-inclined blades and aerodynamic intake. The impellers are statically and dynamically balanced.

Max. operating temperature: 60°C

Number of blades are reduced by 2 for paper impeller.

Available in anti-spark version with stainless steel inlet and explosion-proof (Eex) motor.

Dimensions (D) for the inlet are external. Supplied smooth.

Specific dimensions for the outlet flanges can be found under "Flanges".

The technical data for each type appears on the following pages.

The blowers are as default delivered in position RV (LG270 according to Eurovent).

Steel plate dimensions in mm

Type	MTD 20 - MTD 30	MTD 35 - MTD 40
Impeller - standard	4	5
Impeller - reinforced	8	8
Fan housing - standard	3	3
Fan housing - reinforced	6	8

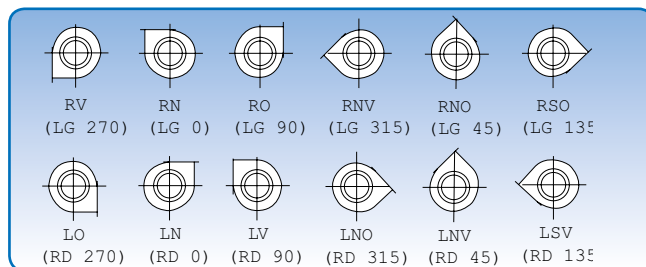

6 positions. The position illustrations are viewed from the inlet side.

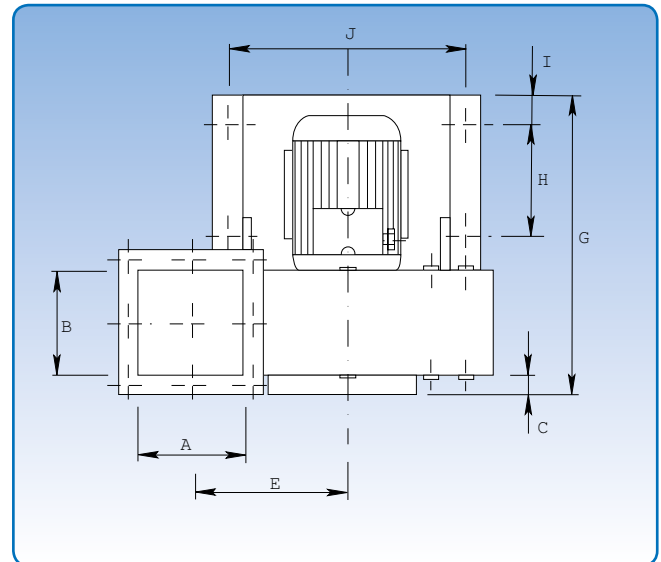
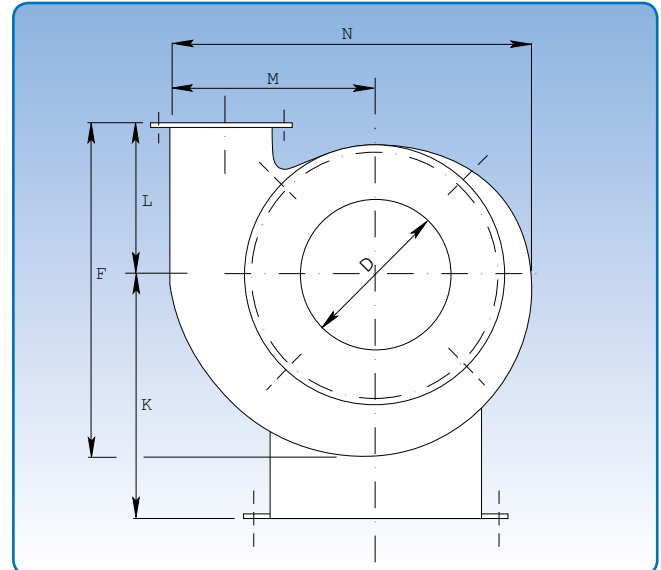

Type	Dimensions														Weight without motor kg
	A mm	B mm	C mm	D mm	E mm	F mm	G mm	H mm	I mm	J mm	K mm	L mm	M mm	N mm	
MTD 20	140	140	33	200	207	448	400	141	40	317	325	198	284	500	27
MTD 22	166	166	29	225	220	500	475	192	40	326	340	224	310	552	34
MTD 25	186	186	30	250	248	582	530	210	50	356	384	273	348	618	45
MTD 30	206	206	36	300	267	631	577	230	50	356	415	293	377	676	50
MTD 35	225	225	45	350	320	670	735	360	50	390	515	293	438	770	73
MTD 40	251	251	55	400	330	740	795	400	50	488	500	326	462	824	88

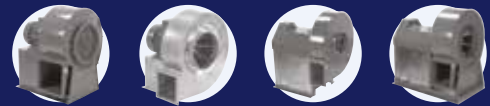

Fan type MTD 20

Technical data

Motor: IP 55

Supplied with the following motors:

kW	hp	amp.	Weight of motor kg
1,1	1,5	4,3	10

Max. min⁻¹:

Standard impeller: 3.200 min⁻¹
 Reinforced impeller: 2.840 min⁻¹

Operating range:

Air volume: 750 - 1.800 m³/h
 Pressure: 110 - 155 mmWG

Power supply:

230 V - 50 Hz.

Construction:

B3 - motor mounted on foot.

Variants:

Fan can be powered by flange motor
 - type B5/B14.

Impeller:

No. of blades, standard: 8 pcs.
 Diameter: ø295 mm
 Height: 114 mm

The blue curve applies for 6-bladed impeller.

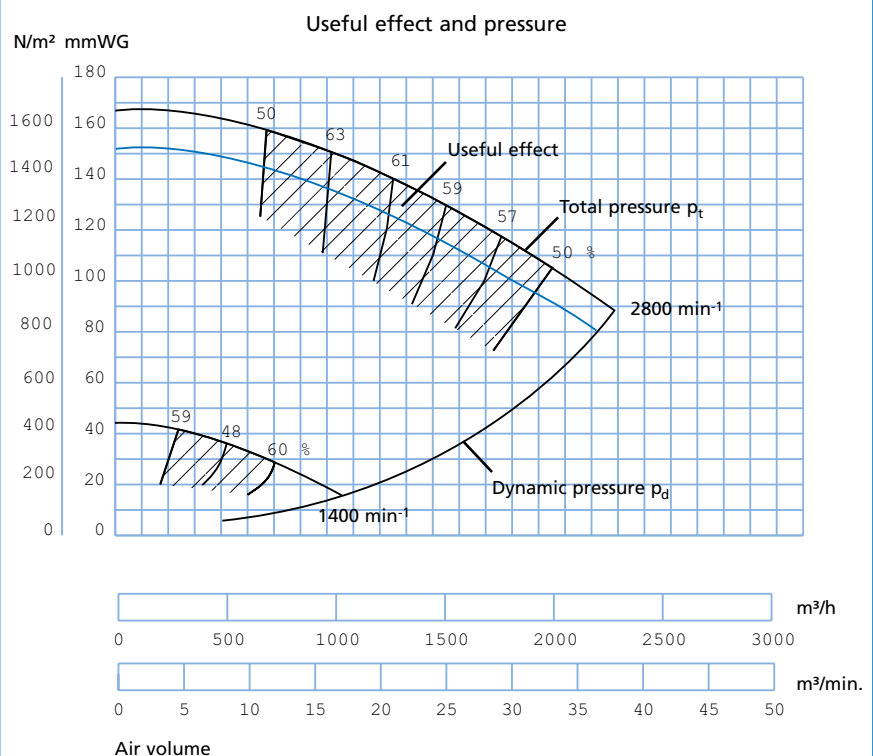
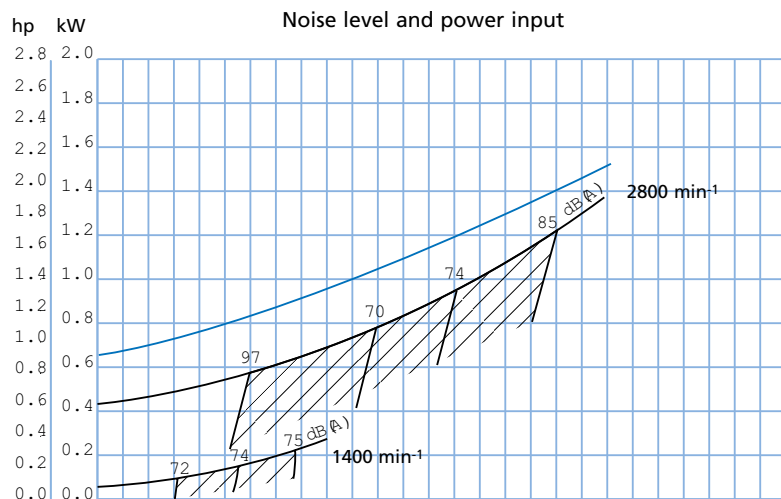

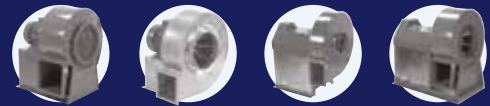

Fan type MTD 22

Technical data

Motor: IP 55

Supplied with the following motors:

kW	hp	amp.	Weight of motor kg
2,2	3,0	8,0	14

Max. min⁻¹:

Standard impeller: 3.200 min⁻¹
 Reinforced impeller: 2.865 min⁻¹

Operating range:

Air volume: 1.000 - 3.100 m³/h
 Pressure: 130 - 200 mmWG

Power supply:

230 V - 50 Hz.

Construction:

B3 - motor mounted on foot.

Variants:

Fan can be powered by flange motor
 - type B5/B14.

Impeller:

No. of blades, standard: 8 pcs.
 Diameter: ø300 mm
 Height: 139 mm

The blue curve applies for 6-bladed impeller.

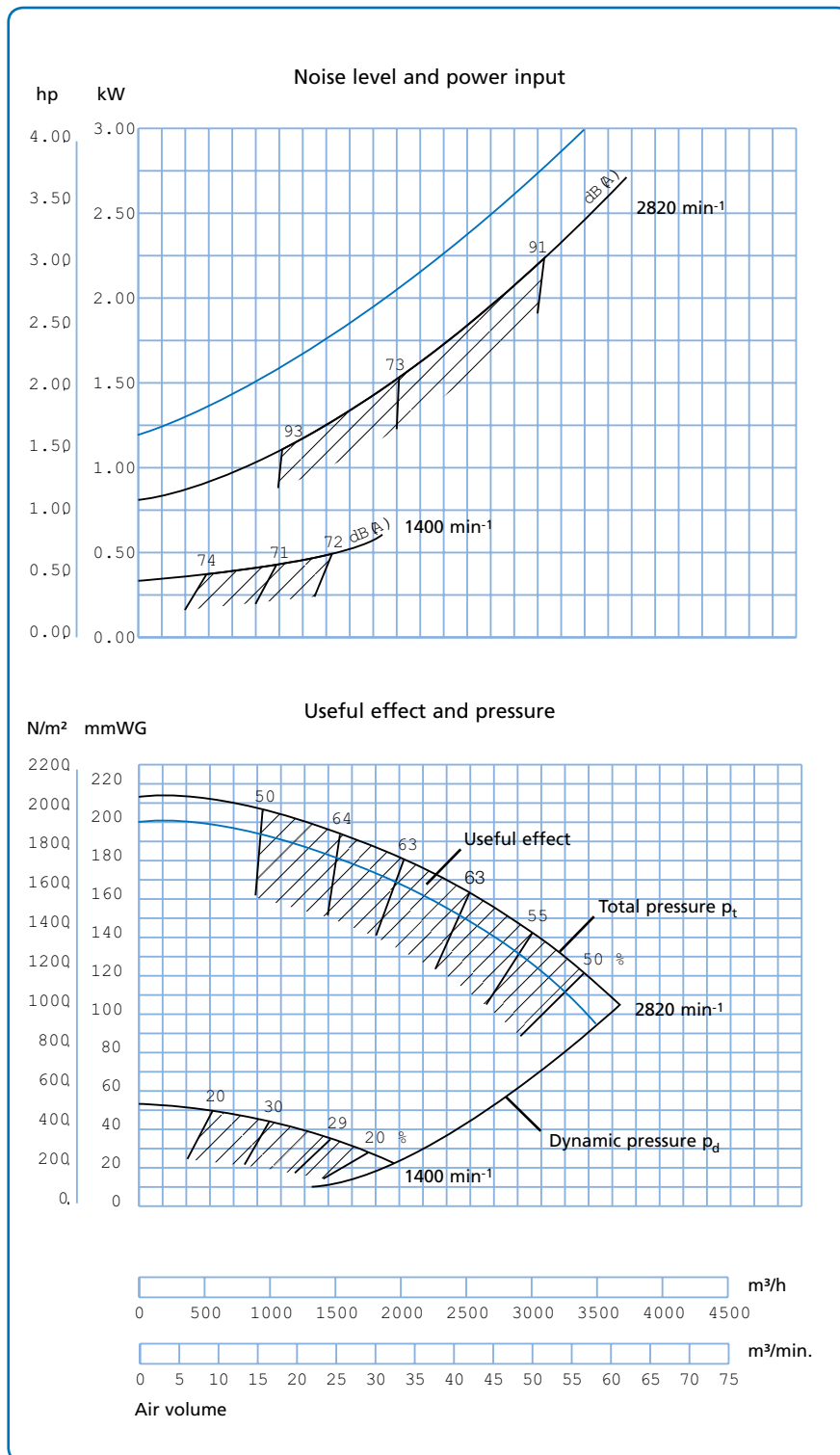

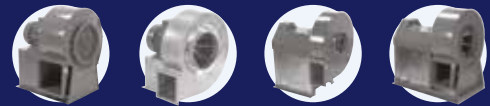

Fan type MTD 25

Technical data

Motor: IP 55

Supplied with the following motors:

kW	hp	amp.	Weight of motor kg
4,0	5,5	7,7	31

Max. min⁻¹:

Standard impeller: 3.200 min⁻¹
 Reinforced impeller: 2.865 min⁻¹

Operating range:

Air volume: 1.500 - 4.500 m³/h
 Pressure: 160 - 240 mmWG

Power supply:

400 V - 50 Hz.

Construction:

B3 - motor mounted on foot.

Variants:

Fan can be powered by flange motor
 - type B5/B14.

Impeller:

No. of blades, standard: 8 pcs.
 Diameter: ø360 mm
 Height: 143 mm

The blue curve applies for 6-bladed impeller.

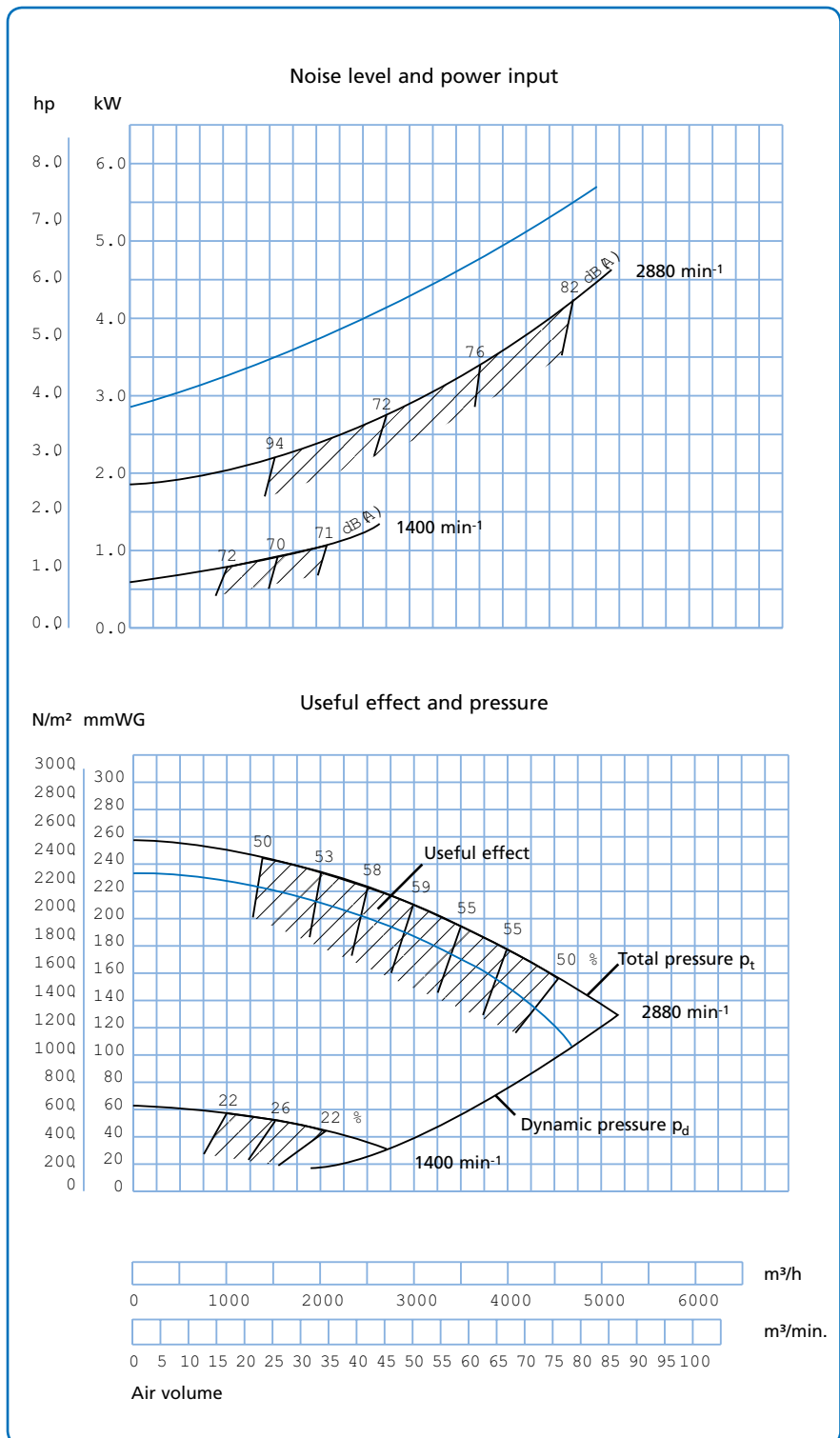



Fan type MTD 30

Technical data

Motor: IP 55

Supplied with the following motors:

kW	hp	amp.	Weight of motor kg
5,5	7,5	11,1	43
7,5	10,0	14,7	49

Max. min⁻¹:

Standard impeller: 3.200 min⁻¹
 Reinforced impeller: 2.895 min⁻¹

Operating range:

Air volume: 2.500 - 6.500 m³/h
 Pressure: 200 - 290 mmWG

Power supply:

400 V - 50 Hz.

Construction:

B3 - motor mounted on foot.

Variants:

Fan can be powered by flange motor
 - type B5/B14.

Impeller:

No. of blades, standard: 8 pcs.
 Diameter: ø410 mm
 Height: 154 mm

The blue curve applies for 6-bladed impeller.

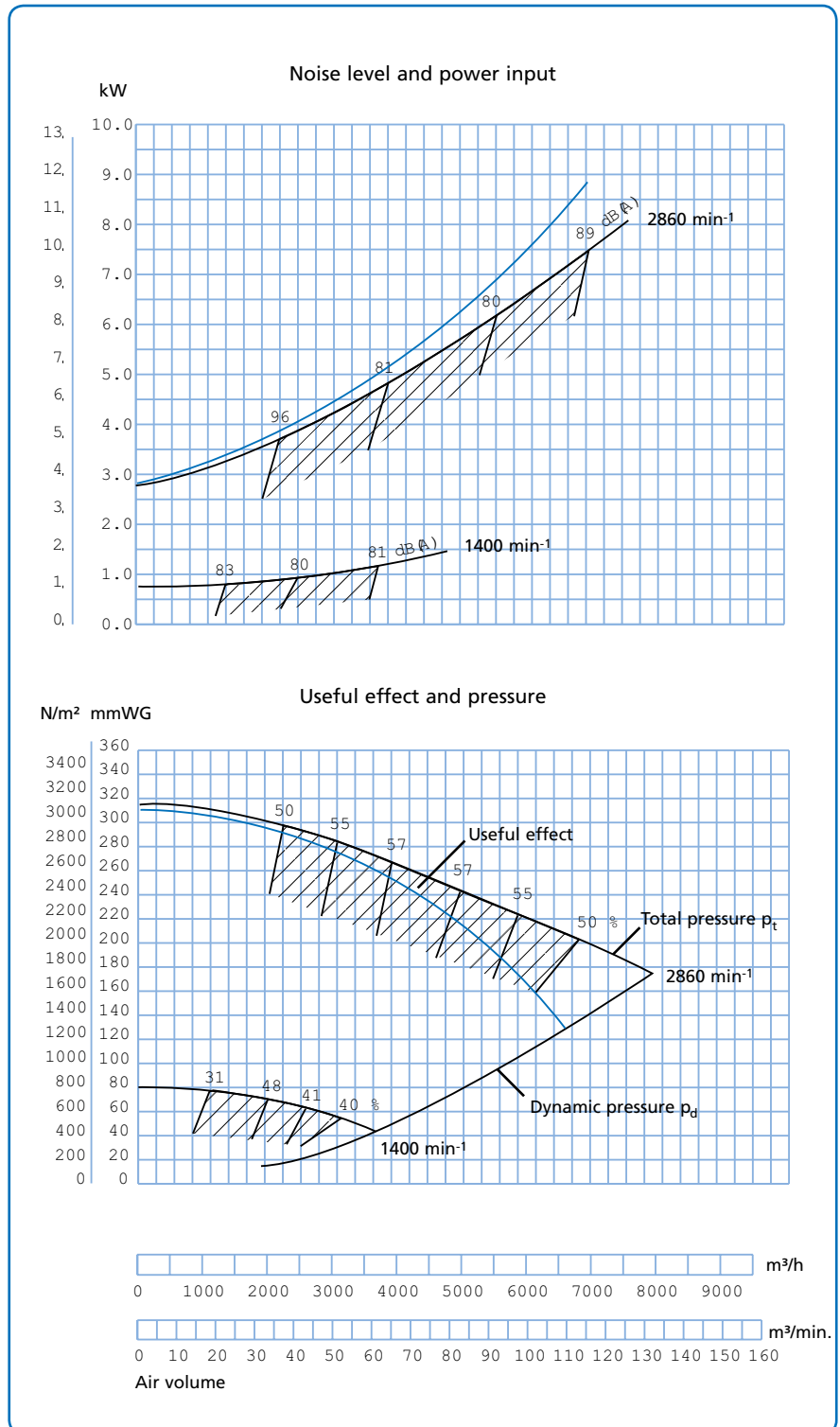

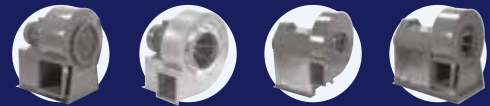

Fan type MTD 35

Technical data

Motor: IP 55

Supplied with the following motors:

kW	hp	amp.	Weight of motor kg
11,0	15,0	21,2	69
15,0	20,0	28,2	83

Max. min⁻¹:

Standard impeller: 3.200 min⁻¹
 Reinforced impeller: 2.915 min⁻¹

Operating range:

Air volume: 3.000 - 8.500 m³/h
 Pressure: 260 - 375 mmWG

Power supply:

400 V - 50 Hz.

Construction:

B3 - motor mounted on foot.

Variants:

Fan can be powered by flange motor
 - type B5/B14.

Impeller:

No. of blades, standard: 8 pcs.
 Diameter: ø450 mm
 Height: 185 mm

The blue curve applies for 6-bladed impeller.

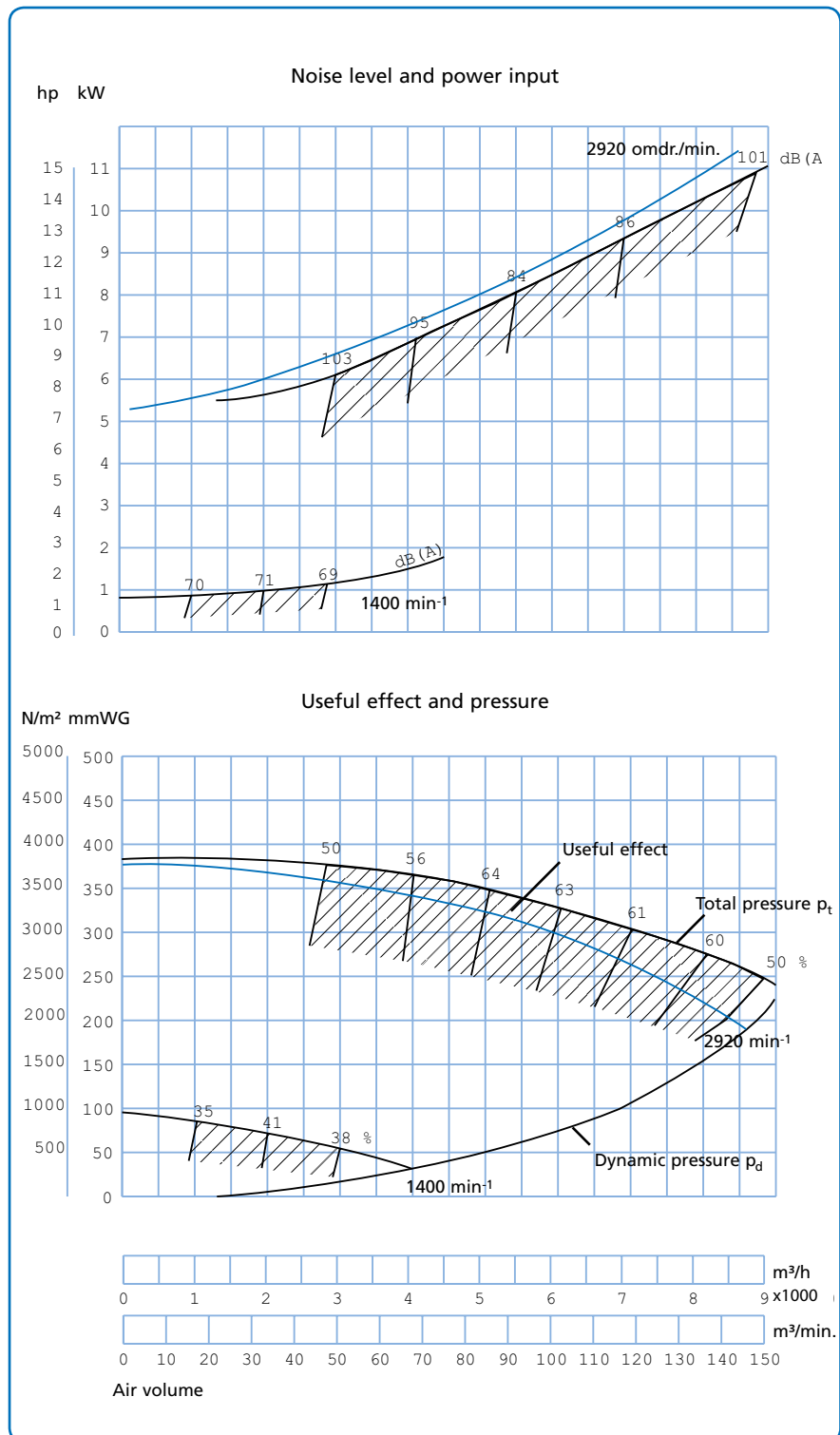



Fan type MTD 40

Technical data

Motor: IP 55

Supplied with the following motors:

kW	hp	amp.	Weight of motor kg
18,5	25,0	34,4	87
22,0	30,0	40,0	165

Max. min⁻¹:

Standard impeller: 3.200 min⁻¹

Reinforced impeller: 2.930 min⁻¹

Operating range:

Air volume: 5.000 - 11.000 m³/h

Pressure: 340 - 440 mmWG

Power supply:

400 V - 50 Hz.

Construction:

B3 - motor mounted on foot.

Variants:

Fan can be powered by flange motor

- type B5/B14.

Impeller:

No. of blades, standard: 8 pcs.

Diameter: ϕ 500 mm

Height: 185 mm

The blue curve applies for 6-bladed impeller.

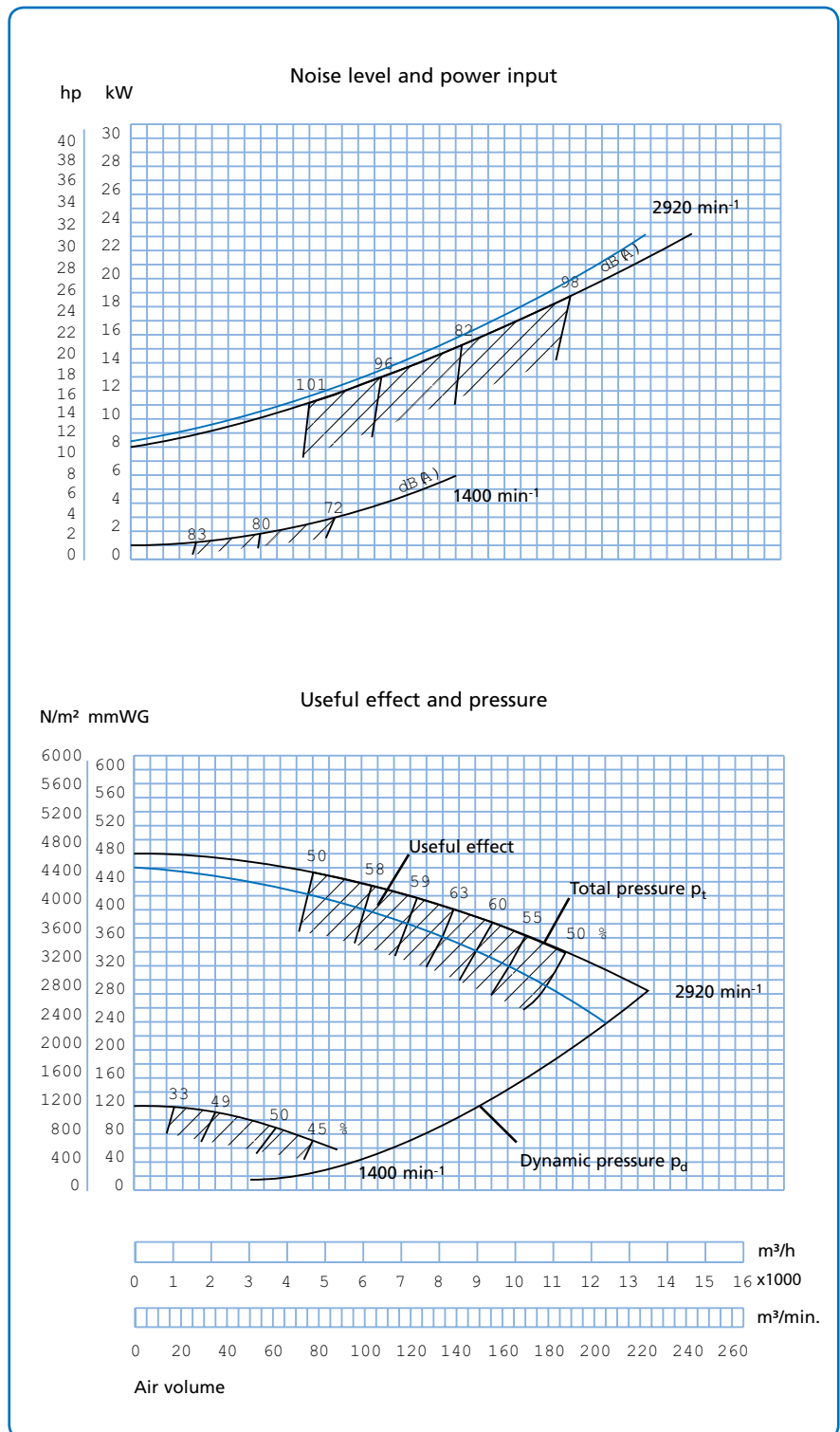



Fan types MTK 40 - MTK 75

The indirect drive centrifugal fan types MTK 40 - MTK 75 are designed for material handling.

Equipped with self-cleaning impellers with backward-inclined blades and aerodynamic intake. The impellers are statically and dynamically balanced.

The pulleys are shaft-mounted with taperlock bushing, allowing easy replacement for changed fan speed.

Max. operating temperature: 60°C

With cooling wings: Up to 200°C

Number of blades are reduced by 2 for paper impeller.

Available in anti-spark version with stainless steel inlet and explosion-proof (Ex) motor.

Dimensions (D) for the inlet are external. Supplied smooth.

Belt drive is anti-static.

Specific dimensions for the outlet flanges can be found under "Flanges".

The technical data for each type appears on the following pages.

The blowers are as default delivered in position RV (LG270 according to Eurovent).

Steel plate dimensions in mm

Type	MTK 40/45	MTK 55	MTK 75
Impeller - standard	5		6
Impeller - reinforced	8	8	8
Fan housing - standard	3		4
Fan housing - reinforced	8		8

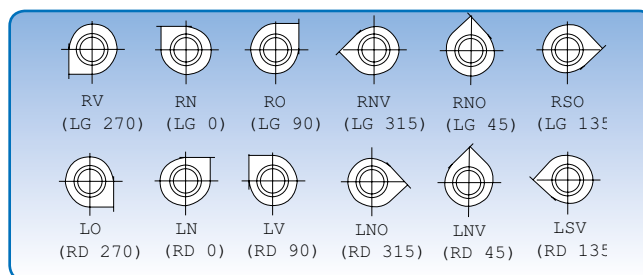
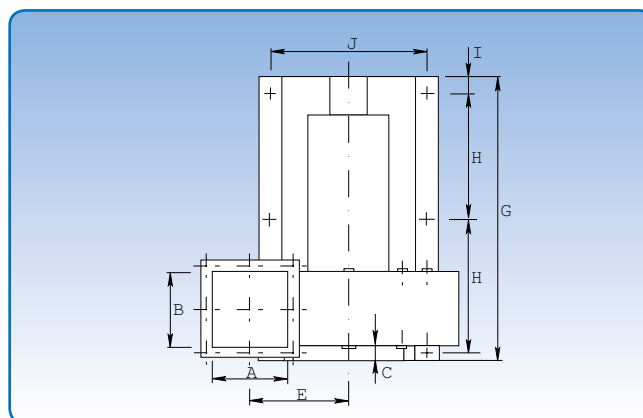
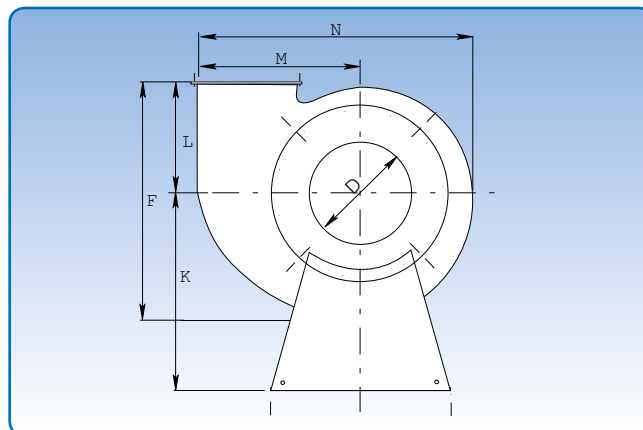

6 positions. The position illustrations are viewed from the inlet side.

Type	Dimensions														Weight without motor kg
	A mm	B mm	C mm	D mm	E mm	F mm	G mm	H mm	I mm	J mm	K mm	L mm	M mm	N mm	
MTK 40	250	250	55	400	330	740	1110	494	55	550	650	326	462	824	200
MTK 45	339	339	55	450	395	885	1207	528	55	672	720	375	570	1013	300
MTK 55	418	418	60	550	500	1095	1540	700	59	825	955	468	715	1250	532
MTK 75	700	550	60	750	442	1310	1875	855	70	850	1125	600	800	1410	597



Fan type MTK 40

Technical data

Motor: IP 55

Supplied with the following motors:

kW	hp	amp.	Weight of motor kg
11,0	15,0	21,2	69
15,0	20,0	28,2	83

Max. min⁻¹:

Standard impeller: 3,435 min⁻¹

Reinforced impeller: 2,600 min⁻¹

Operating range:

Air volume: 5,000 – 11,000 m³/h

Pressure: 140 – 540 mm WG

Power supply:

400 V - 50 Hz.

Construction:

B3 - motor mounted on foot.

Impeller:

No. of blades, standard: 8 pcs.

Diameter: ø500 mm

Height: 189 mm

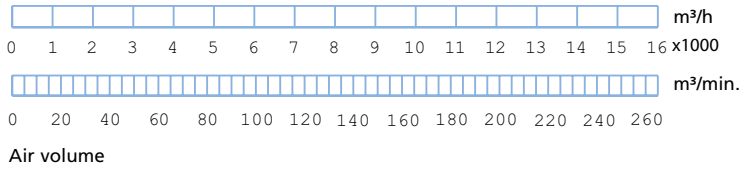
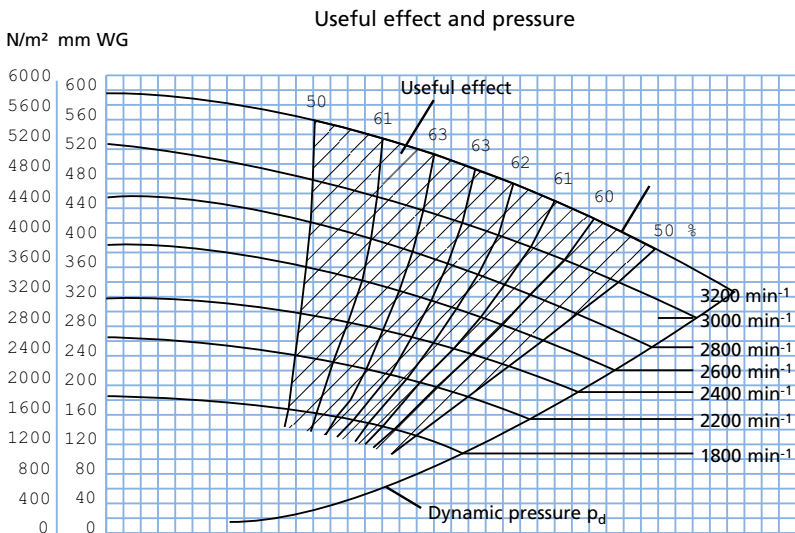
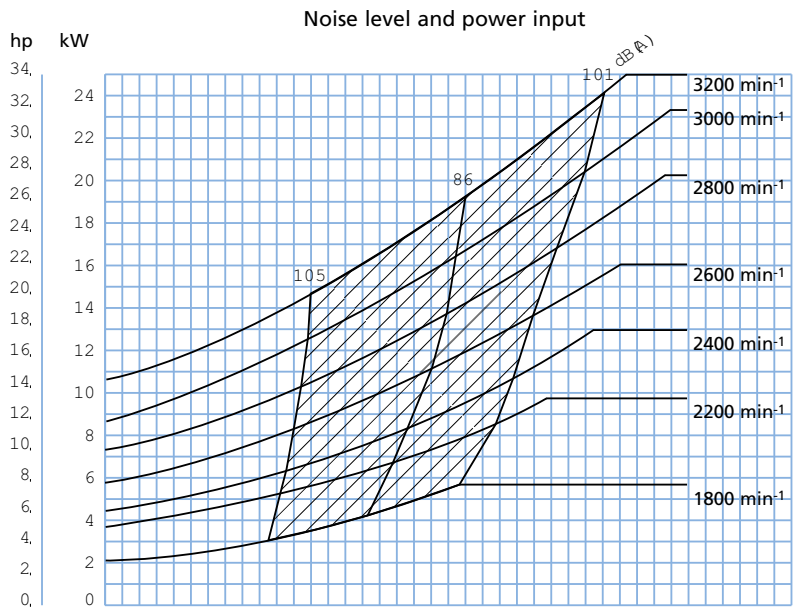



Fan type MTK 45

Technical data

Motor: IP 55

Supplied with the following motors:

kW	hp	amp.	Weight of motor kg
18,5	25,0	34,4	87
22,0	30,0	40,0	165
30,0	40,0	52,5	240

Max. min⁻¹:

Standard impeller: 2.450 min⁻¹

Reinforced impeller: 1.850 min⁻¹

Operating range:

Air volume: 6.000 - 20.000 m³/h

Pressure: 180 - 520 mmWG

Power supply:

400 V - 50 Hz.

Construction:

B3 - motor mounted on foot.

Impeller:

No. of blades, standard: 8 pcs.

Diameter: ø650 mm

Height: 259 mm

The blue curve applies for 6-bladed impeller and at 1950 min⁻¹.

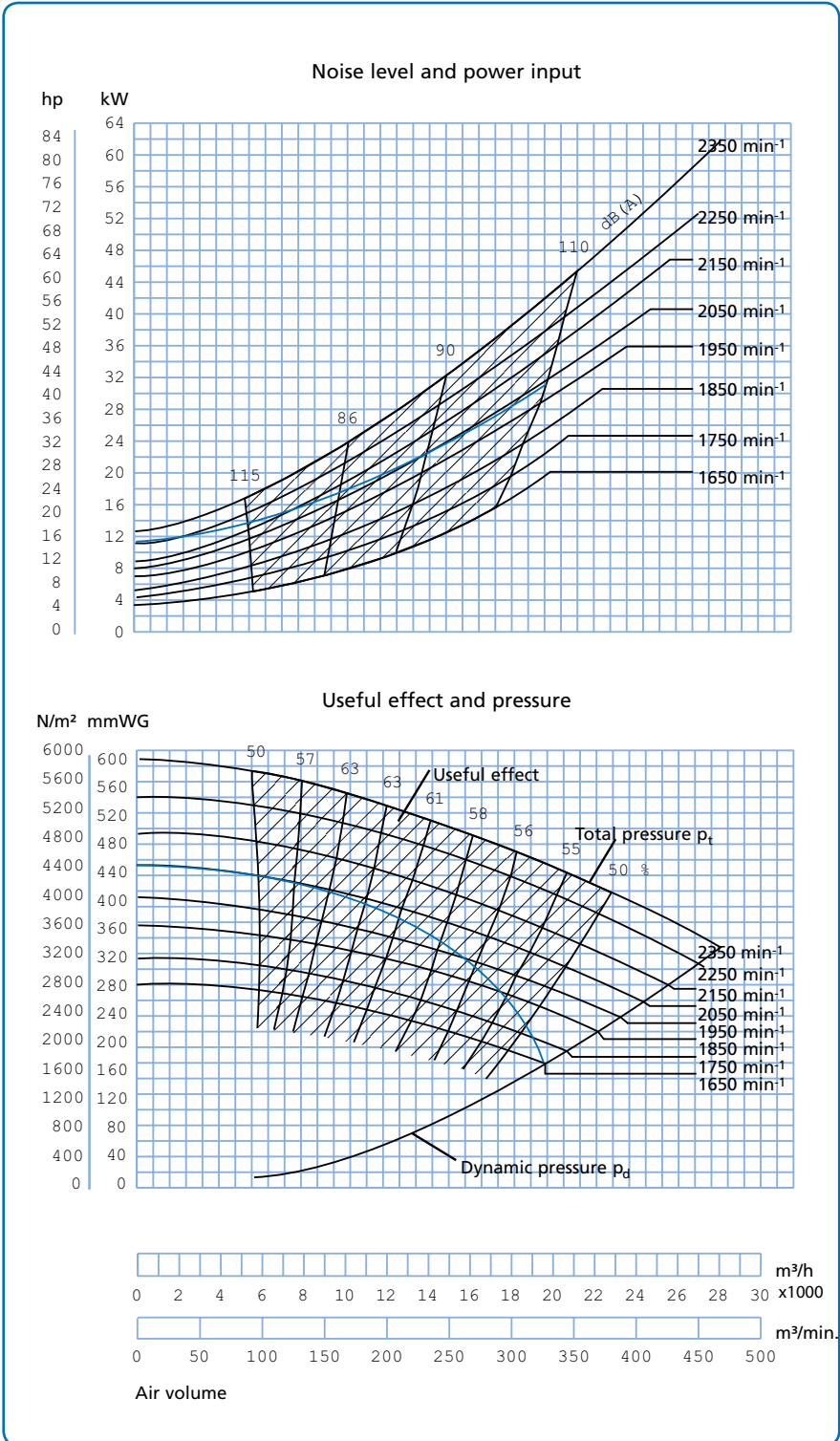

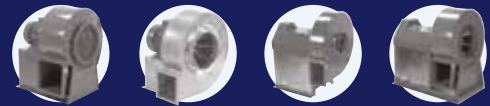

Fan type MTK 55

Technical data

Motor: IP 55

Supplied with the following motors:

kW	hp	amp.	Weight of motor kg
30,0	40,0	53	230
37,0	50,0	67	300
45,0	60,0	80	330
55,0	75,0	97	435

Max. min⁻¹:

Standard impeller: 2.050 min⁻¹

Reinforced impeller: 2.050 min⁻¹

Operating range:

Air volume: 8.000 - 29.000 m³/h

Pressure: 160 - 600 mmWG

Power supply:

400 V - 50 Hz.

Construction:

B3 - motor mounted on foot.

Impeller:

No. of blades, standard: 8 pcs.

Diameter: ø800 mm

Height: 320 mm

The blue curve applies for 6-bladed impeller and at 1850 min⁻¹.

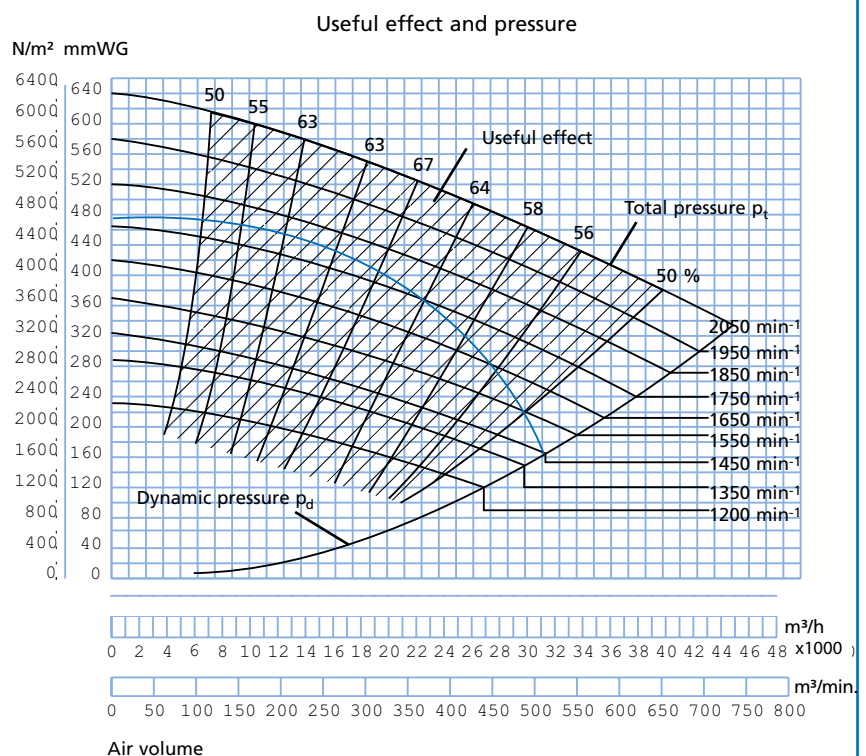
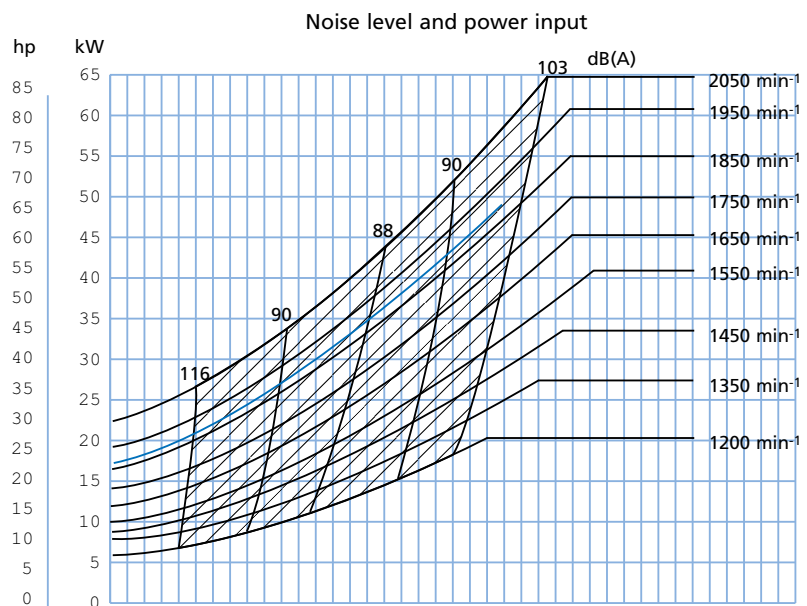



Fan type MTK 75

Technical data

Motor: IP 55

Supplied with the following motors:

kW	hp	amp.	Weight of motor kg
55,0	75,0	97,0	435
75,0	103,0	133,0	610

Max. min⁻¹:

Standard impeller: 2,050 min⁻¹

Reinforced impeller: 1,450 min⁻¹

Operating range:

Air volume: 25,000 – 40,000 m³/h

Pressure: 200 – 370 mm WG

Power supply:

400 V - 50 Hz.

Construction:

B3 - motor mounted on foot.

Impeller:

No. of blades, standard: 8 pcs.

Diameter: ø890 mm

Height: 430 mm

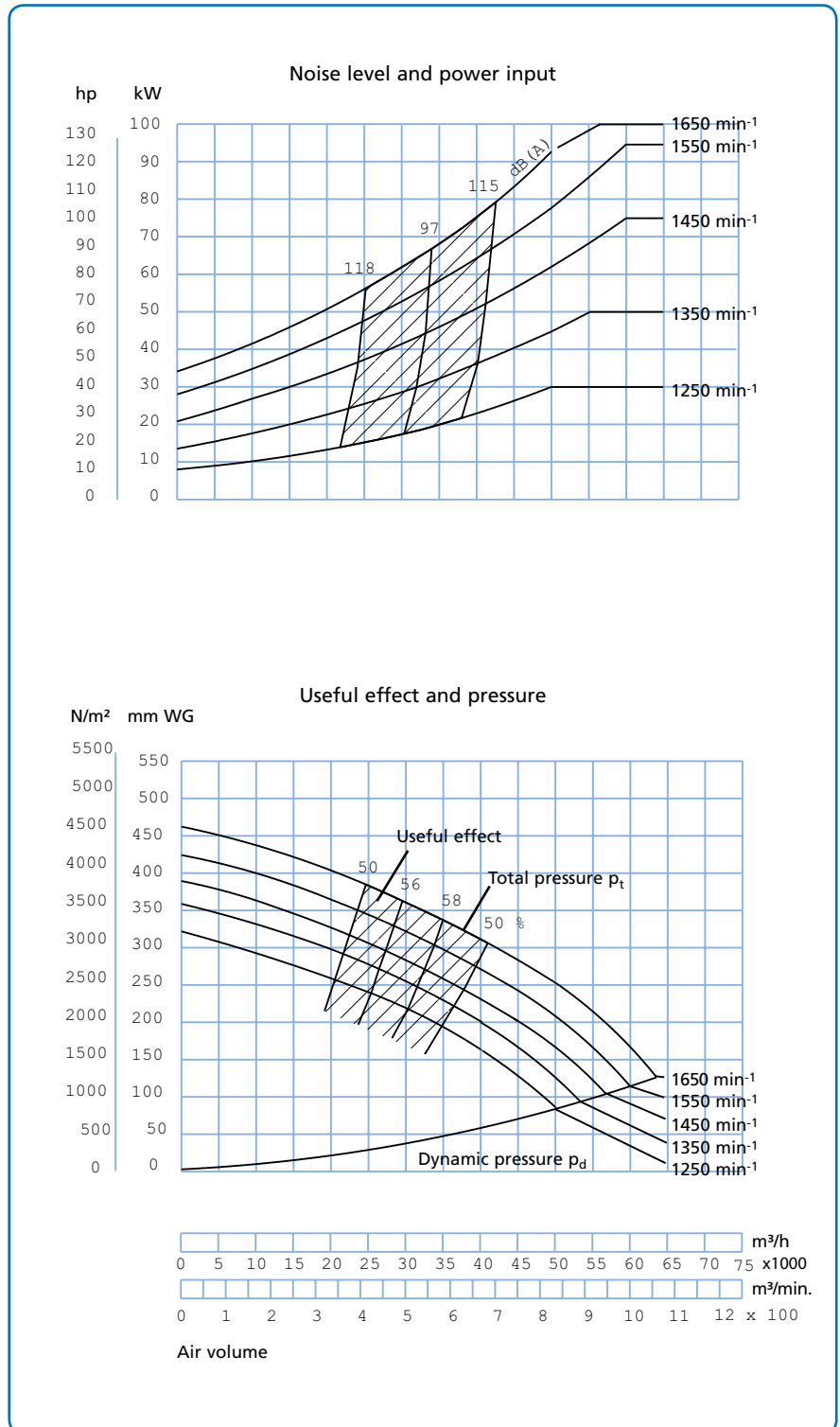

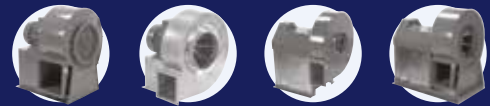

Fan type BTD/BPD/BTK/BPK 200 - 500

The indirect driven centrifugal fan types BTK/BPK 200 - 500 and direct driven fan types BTD/BPD 200 - 500 is designed for concentrated material handling over long distances.

The impellers are available in 2 versions, an open T-impeller for coarse-grained or rather long material types and a closed P-impeller for dust particles (< 2 mm).

The impeller for paper is always made as open T-impeller with 6 blades.

T-impeller is available in wear-resistant material HARDOX.

The impeller is statically and dynamically balanced.

The fan is available in anti-spark version with stainless steel inlet and explosion-proof (Eex) motor.

The pulleys are fitted with taperlock. This means that they can be easily re-placed if the number of revolutions has to be changed.

Max. operating temperature: 60°C

With cooling wings: Up to 200°C (only K-models)

BTD/BPD/ BTK/BPK 200 - 300 and with flange on BTD/BPD/ BTK/ BPK 400 - 500.

Specific dimensions for the outlet flanges can be found under “Flanges”.

The technical data for each type appears on the following pages.

Effects measured according to ISO 5801.

The blowers are as default delivered in position RV (LG270 according to Eurovent).

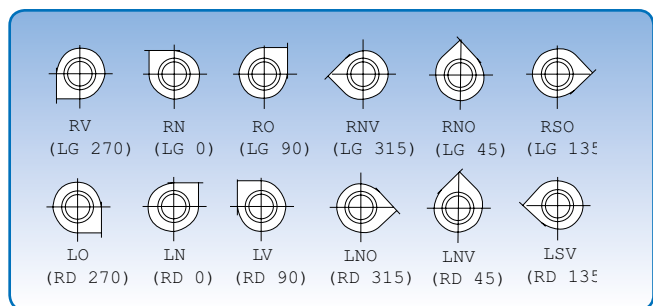

6 positions. The position illustrations are viewed from the inlet side.

Dimensions (D) for the inlet are external, and is supplied smooth on

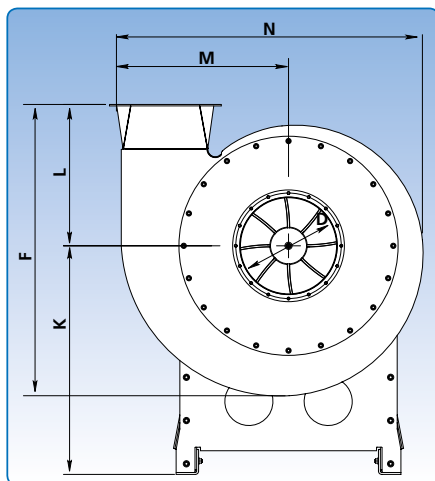

T-DIK

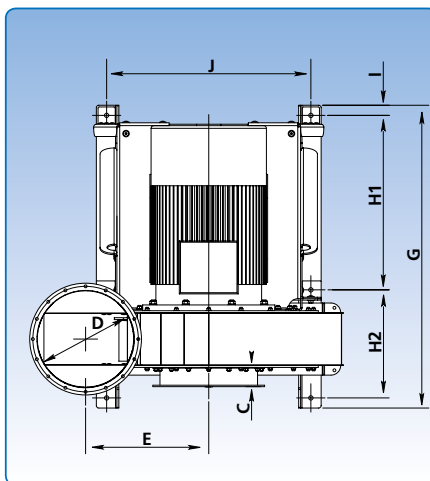

T-D

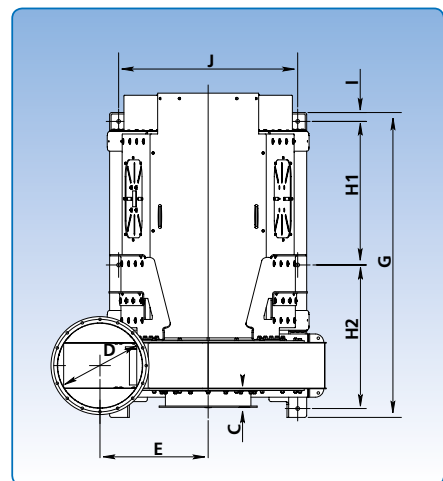

T-K

Type	Dimensions													Weight without motor kg
	C mm	D mm	E mm	F mm	G mm	H1 mm	H2 mm	I mm	J mm	K mm	L mm	M mm	N mm	
BTK/BPK 200	100	200	352	896	1099	506	506	42	671	720	496	454	834	257
BTK/BPK 300	75	300	380	1076	1255	584	584	42	786	860	591	533	971	371
BTK/BPK 400	106	400	514	1212	1436	676	676	42	850	1008	588	716	1273	627
BTK/BPK 500	215	500	522	1361	1668	792	792	42	932	1193	693	774	1366	677
BTD/BPD 200	100	200	352	896	934	305	545	38	671	720	496	454	834	219
BTD/BPD 300	75	300	380	1076	1110	366	660	38	760	860	591	533	971	328
BTD/BPD 400	106	400	514	1212	1208	398	726	37	850	1008	588	716	1273	529
BTD/BPD 500	215	500	522	1361	1535	450	1001	37	850	1193	693	774	1366	646



Fan type BTK 200 and BTD 200

Technical data

Motor: IP 55

Fan BTK 200

Supplied with the following motors:

kW	amp.	Weight of motor kg
15,0	27,5	83
18,5	34,4	87
22,0	40,0	165

Fan BTD 200

Supplied with the following motors:

kW	amp.	Weight of motor kg
15,0	27,5	83
18,5	34,4	87
22,0	39,0	180

Max. min⁻¹:

Standard impeller: 2.940 min.⁻¹

Reinforced impeller: 2.850 min.⁻¹

Operating range T-impeller:

Air volume: 800 - 5.200 m³/h

Pressure: 2.150 - 7.850 Pa

Power supply:

3 x 400 V - 50 Hz.

Construction BTK 200:

B3 - motor mounted on foot.

Construction BTD 200:

B35 - motor mounted with food and flange.

T-impeller:

No. of blades, standard: 8 pcs.

Diameter: ø650 mm

Height: 120 mm

Noise level and power input T-impeller

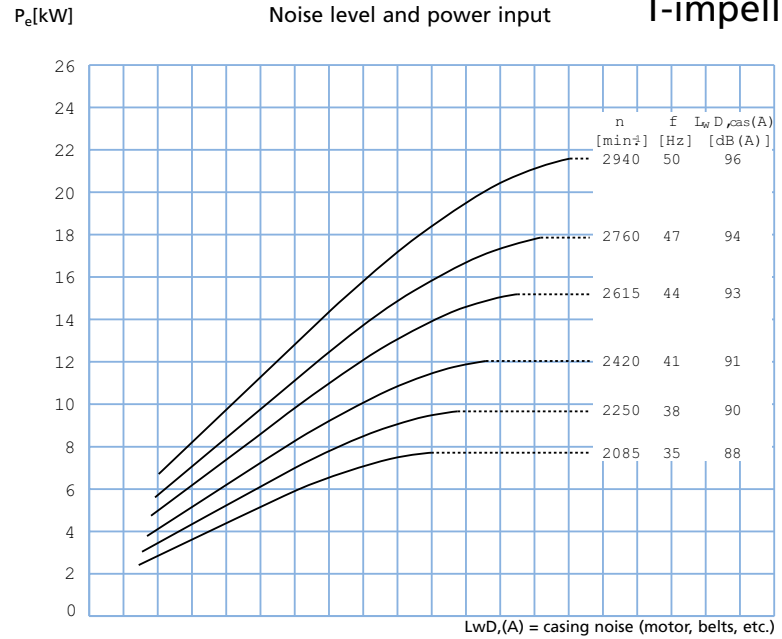

Useful effect and pressure

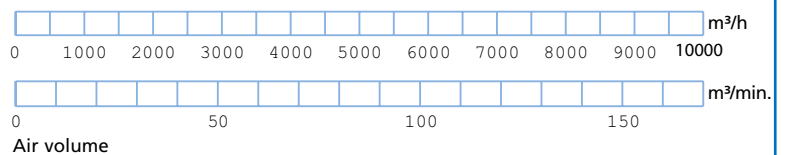
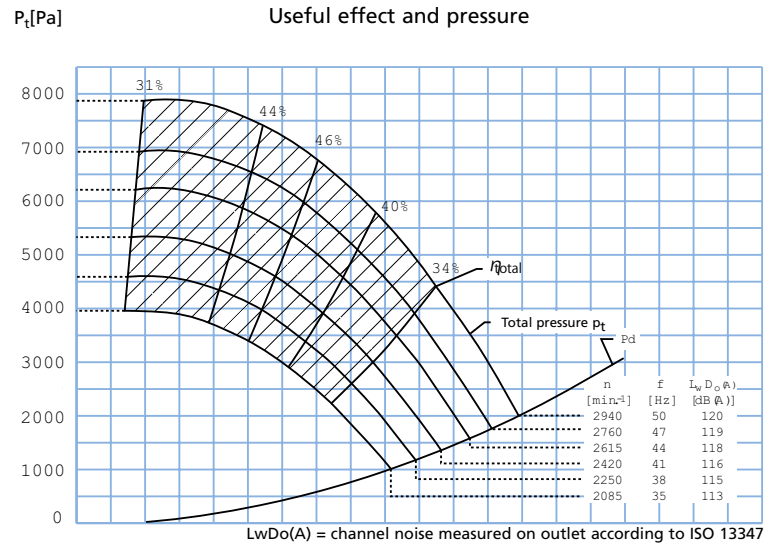



Fan type BPK 200 and BPD 200

Technical data

Motor: IP 55

Fan BPK 200

Supplied with the following motors::

kW	amp.	Weight of motor kg
15,0	27,5	83
18,5	34,4	87
22,0	40,0	165

Fan BPD 200

Supplied with the following motors:

kW	amp.	Weight of motor kg
15,0	27,5	83
18,5	34,4	87
22,0	39,0	180

Max. min⁻¹:

Impeller: 2.940 min.⁻¹

Operating range P-impeller:

Air volume: 1.000 - 6.500 m³/h

Pressure: 1.850 - 8.350 Pa

Power supply:

3 x 400 V - 50 Hz.

Construction BPK 200:

B3 - motor mounted on foot.

Construction BPD 200:

B35 - motor mounted with food and flange.

P-impeller:

No. of blades, standard: 8 pcs.

Diameter: ø654 mm

Height: 131 mm

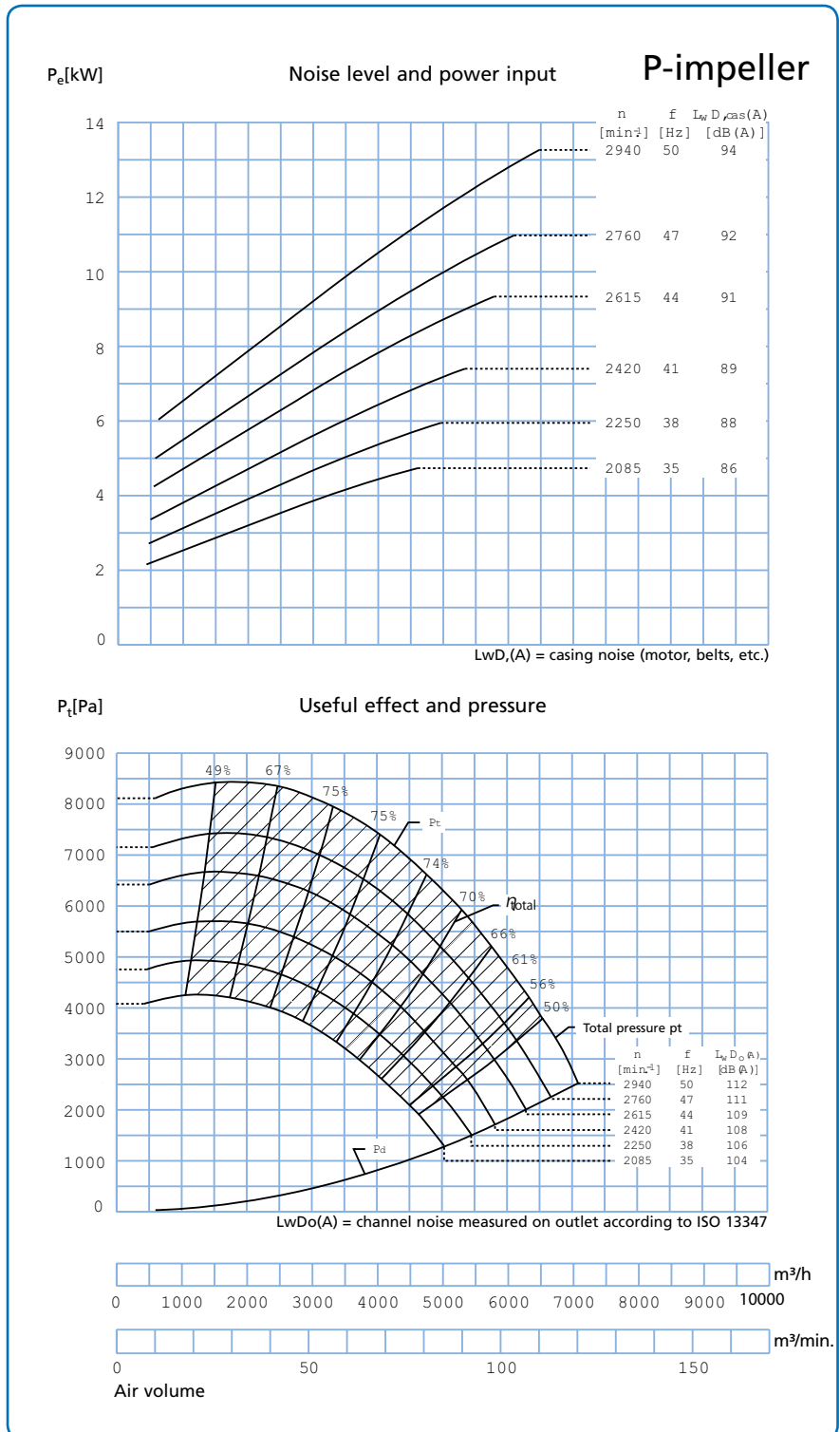



Fan type BTK 300 and BTD 300

Technical data

Motor: IP 55

FanBTK 300

Supplied with the following motors:

kW	amp.	Weight of motor kg
22,0	39,0	180
30,0	52,3	246
37,0	64,5	256
45,0	78,0	328

Fan BTD 300

Supplied with the following motors:

kW	amp.	Weight of motor kg
30,0	52,3	246
37,0	64,5	256
45,0	78,0	328

Max. min⁻¹:

Standard impeller: 2.940 min.⁻¹
 Reinforces impeller: 2.400 min.⁻¹

Operating range T-impeller:

Air volume: 2.000 - 11.000 m³/h
 Pressure: 3.500 - 10.800 Pa

Power supply:

3 x 400 V - 50 Hz.

Construction BTK 300:

B3 - motor mounted on foot.

Construction BTD 300:

B35 - motor mounted with food and flange.

T-impeller:

No. of blades, standard: 8 pcs.

Diameter: ϕ 735 mm

Height: 130 mm

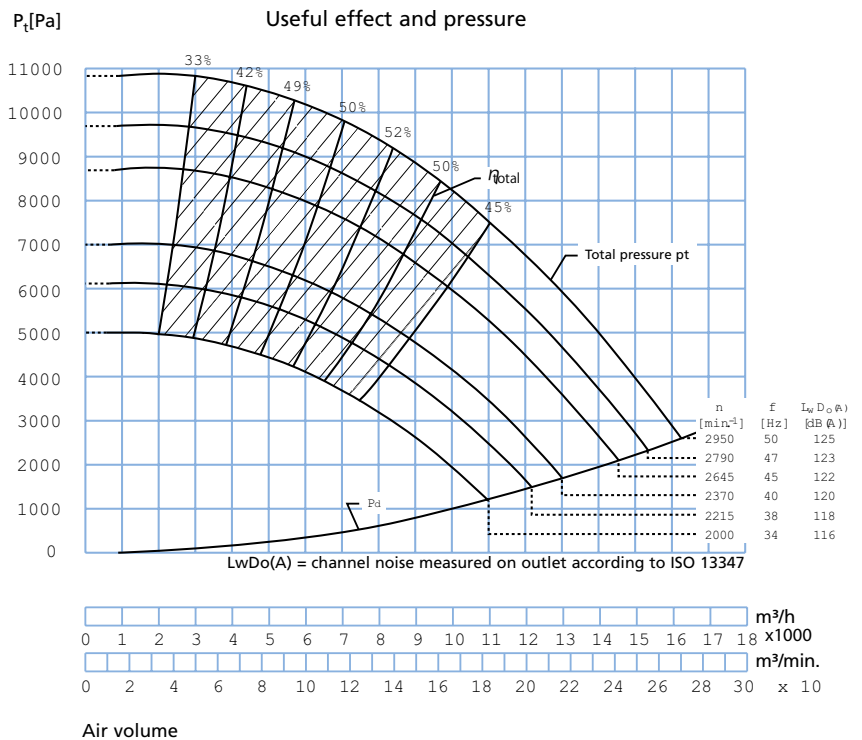
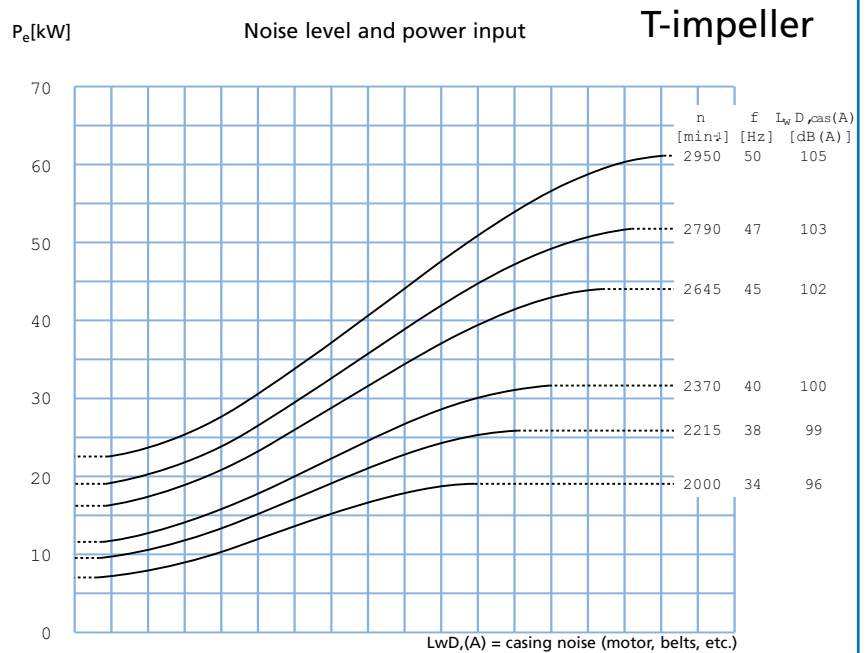

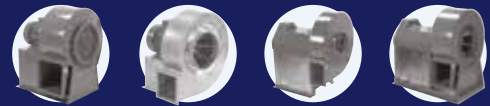

Fan type BPK 300 and BPD 300

Technical data

Motor: IP 55

Fan BPK 300

Supplied with the following motors:

kW	amp.	Weight of motor kg
22,0	39,0	180
30,0	52,3	246
37,0	64,5	256
45,0	78,0	328

Fan BPD 300

Supplied with the following motors:

kW	amp.	Weight of motor kg
30,0	52,3	246
37,0	64,5	256
45,0	78,0	328

Max. min⁻¹:

Impeller: 2.950 min.⁻¹

Operating range P-impeller:

Air volume: 2.000 - 14.000 m³/h

Pressure: 2.500 - 10.800 Pa

Power supply:

3 x 400 V - 50 Hz.

Construction BPK 300:

B3 - motor mounted on foot.

Construction BPD 300:

B35 - motor mounted with food and flange.

P-impeller:

No. of blades, standard: 8 pcs.

Diameter: ø740 mm

Height: 177 mm

Noise level and power input P-impeller

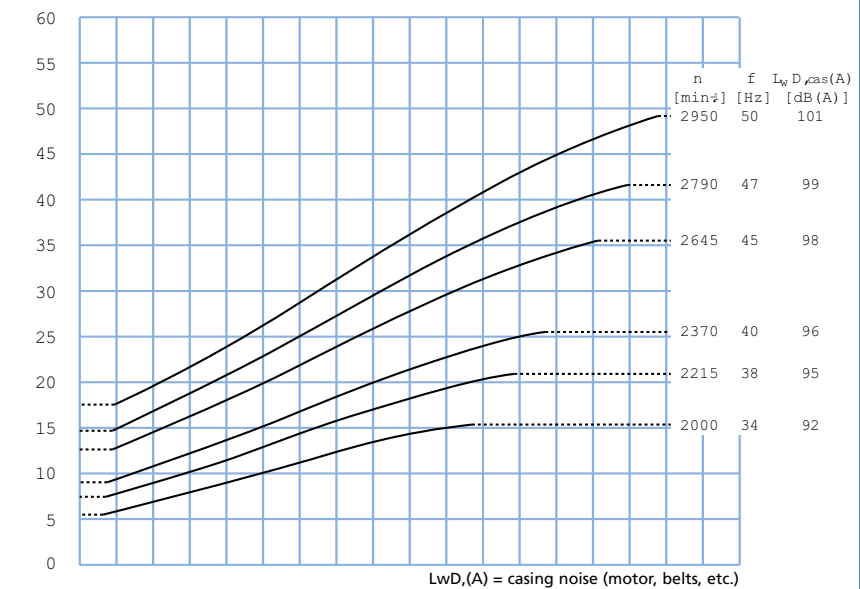

Useful effect and pressure

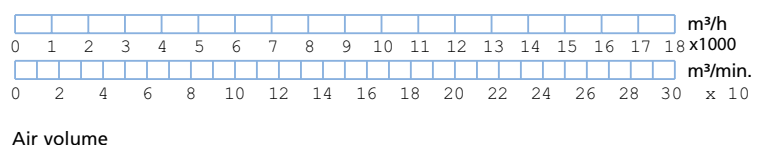
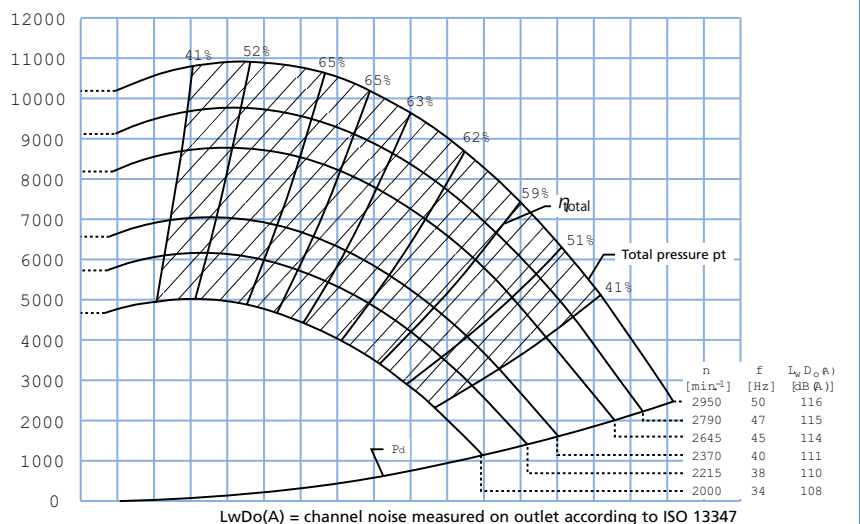

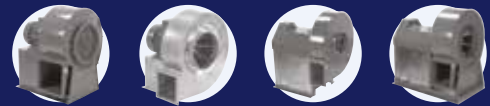

Fan type BTK 400 and BTD 400

Technical data

Motor: IP 55

Fan BTK 400

Supplied with the following motors:

kW	amp.	Weight of motor kg
37,0	65,9	305
45,0	78,0	328
55,0	95,4	452
75,0	129,0	592

Fan BTD 400

Supplied with the following motors:

kW	amp.	Weight of motor kg
55,0	95,4	452
75,0	129,0	592

Max. min⁻¹:

Impeller: 2.955 min.⁻¹

Operating range T-impeller:

Air volume: 2.500 - 17.000 m³/h

Pressure: 3.500 - 11.700 Pa

Power supply:

3 x 400 V - 50 Hz.

Construction BTK 400:

B3 - motor mounted on foot.

Construction BTD 400:

B35 - motor mounted with food and flange.

T-impeller:

No. of blades, standard: 8 pcs.

Diameter: ø786 mm

Height: 199 mm

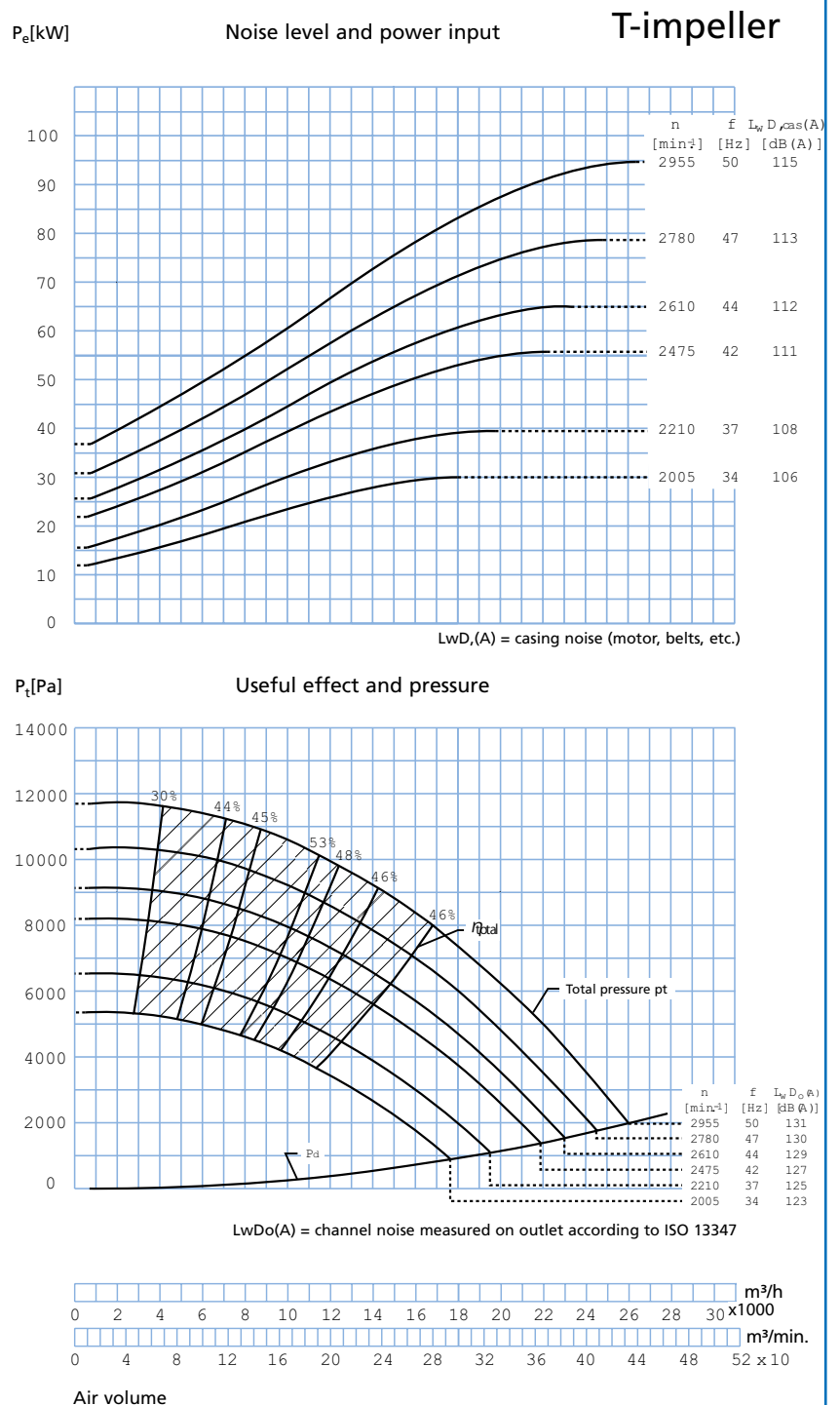

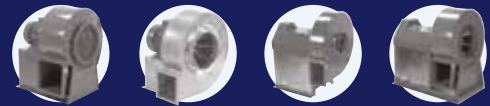

Fan type BPK 400 and BPD 400

Technical data

Motor: IP 55

Fan BPK 400

Supplied with the following motors:

kW	amp.	Weight of motor kg
37,0	65,9	305
45,0	78,0	328
55,0	95,4	452
75,0	129,0	592

Fan BPD 400

Supplied with the following motors:

kW	amp.	Weight of motor kg
55,0	95,4	452
75,0	127,0	592

Max. min⁻¹:

Impeller: 2.955 min.⁻¹

Operating range P-impeller::

Air volume: 4.000 - 23.000 m³/h

Pressure: 2.200 - 11.000 Pa

Power supply:

3 x 400 V - 50 Hz.

Construction BPK 400:

B3 - motor mounted on foot.

Construction BPD 400:

B35 - motor mounted with food and flange.

P-impeller:

No. of blades, standard: 8 pcs.

Diameter: ø769 mm

Height: 240 mm

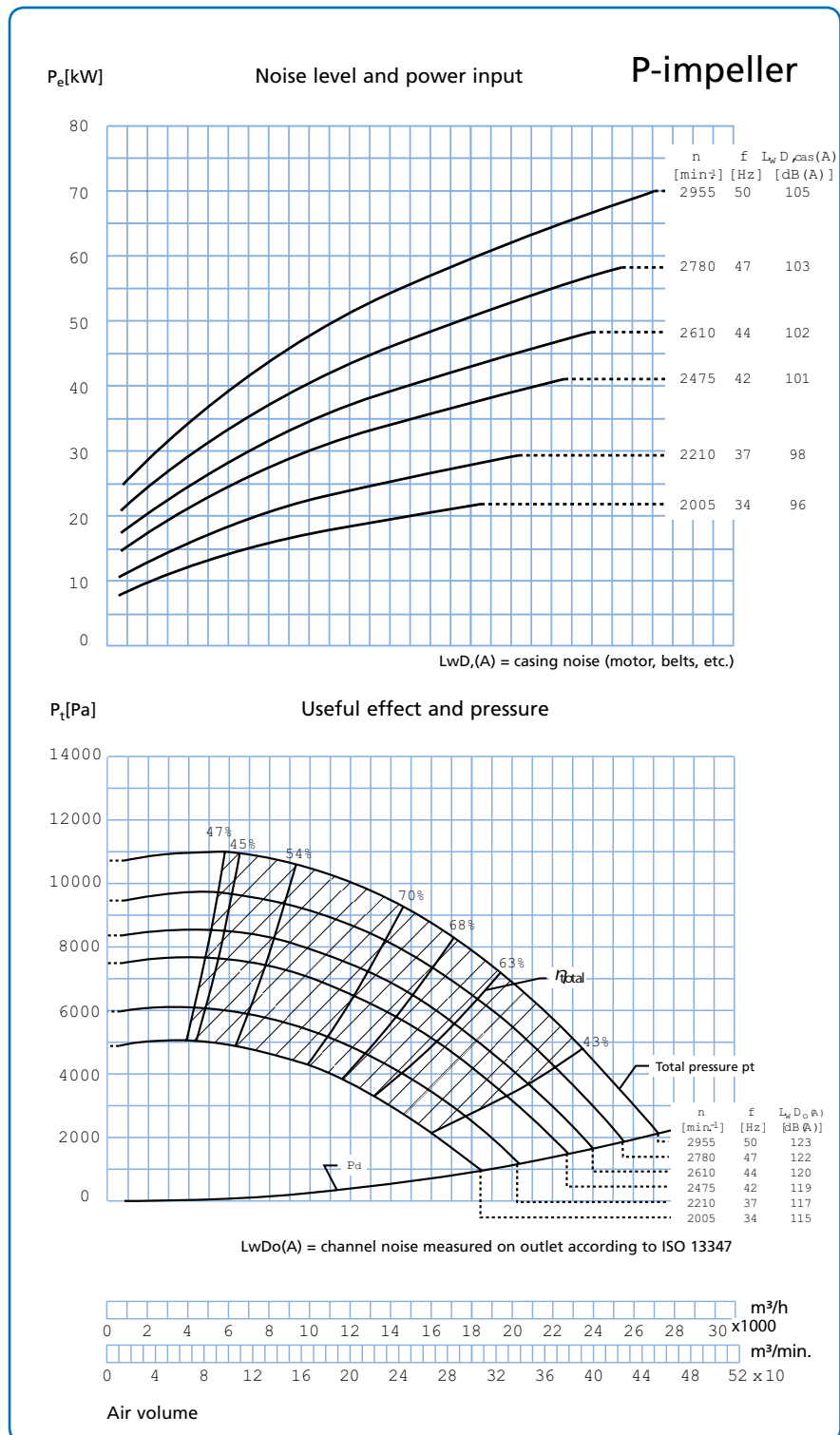



Fan type BTK 500 and BTD 500

Technical data

Motor: IP 55

Fan BTK 500

Supplied with the following motors::

kW	amp.	Weight of motor kg
75,0	129,0	592
90,0	155,0	672
110,0	189,0	980

Fan BTD 500

Supplied with the following motors::

kW	amp.	Weight of motor kg
75,0	129,0	592
90,0	155,0	672
110,0	185,0	950

Max. min⁻¹:

Impeller: 2.955 min.⁻¹

Operating range T-impeller:

Air volume: 3.000 - 25.000 m³/h

Pressure: 3.700 - 12.800 Pa

Power supply:

3 x 400 V - 50 Hz.

Construction BTK 500:

B3 - motor mounted on foot.

Construction BTD 500:

B35 - motor mounted with food and flange.

T-impeller:

No. of blades, standard: 8 pcs.

Diameter: ø805 mm

Height: 250 mm

Pe[kW] Noise level and power input **T-impeller**

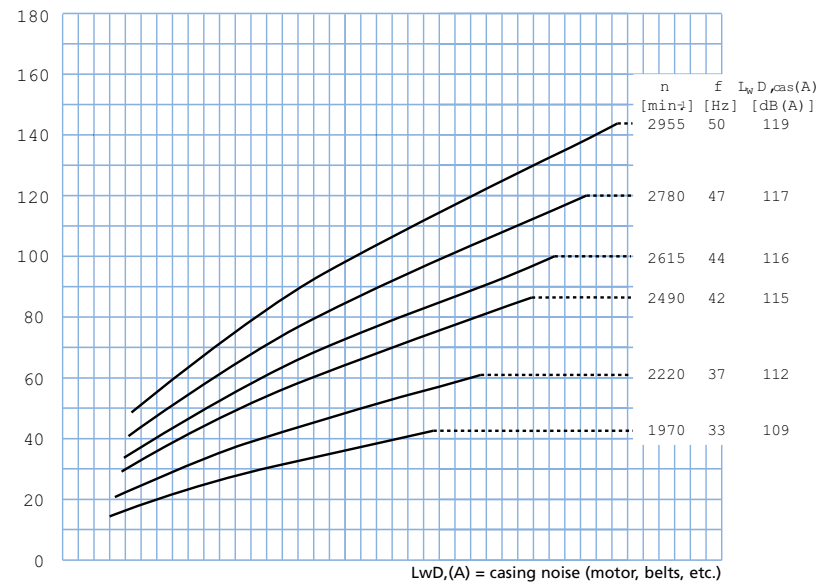

Pt[Pa] Useful effect and pressure

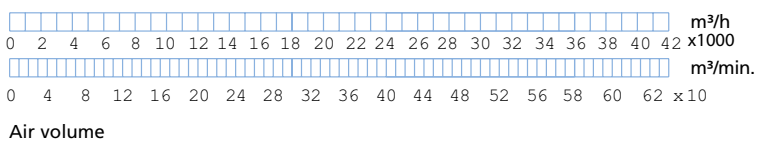
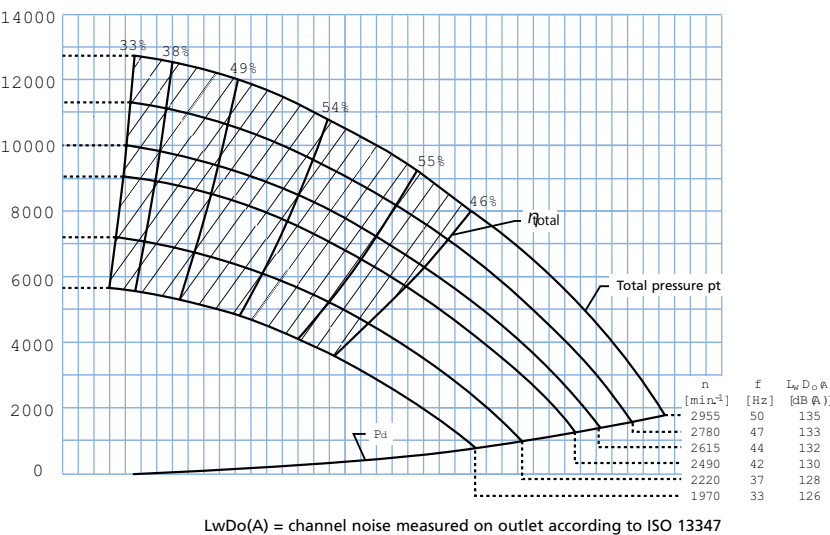



Fan type BPK 500 and BPD 500

Technical data

Motor: IP 55

Fan BPK 500

Supplied with the following motors:

kW	amp.	Weight of motor kg
75	129	592
90	155	672
110	189	980

Fan BPD 500

Supplied with the following motors:

kW	amp.	Weight of motor kg
75	129	592
90	155	672
110	185	950

Max. min⁻¹:

Impeller: 2.955 min.⁻¹

Operating range P-impeller:

Air volume: 5.000 - 37.000 m³/h

Pressure: 1.000 - 11.700 Pa

Power supply:

3 x 400 V - 50 Hz.

Construction BPK 500:

B3 - motor mounted on foot.

Construction BPD 500:

B35 - motor mounted with food and flange.

P-impeller:

No. of blades, standard: 8 pcs.

Diameter: ø805 mm

Height : 285 mm

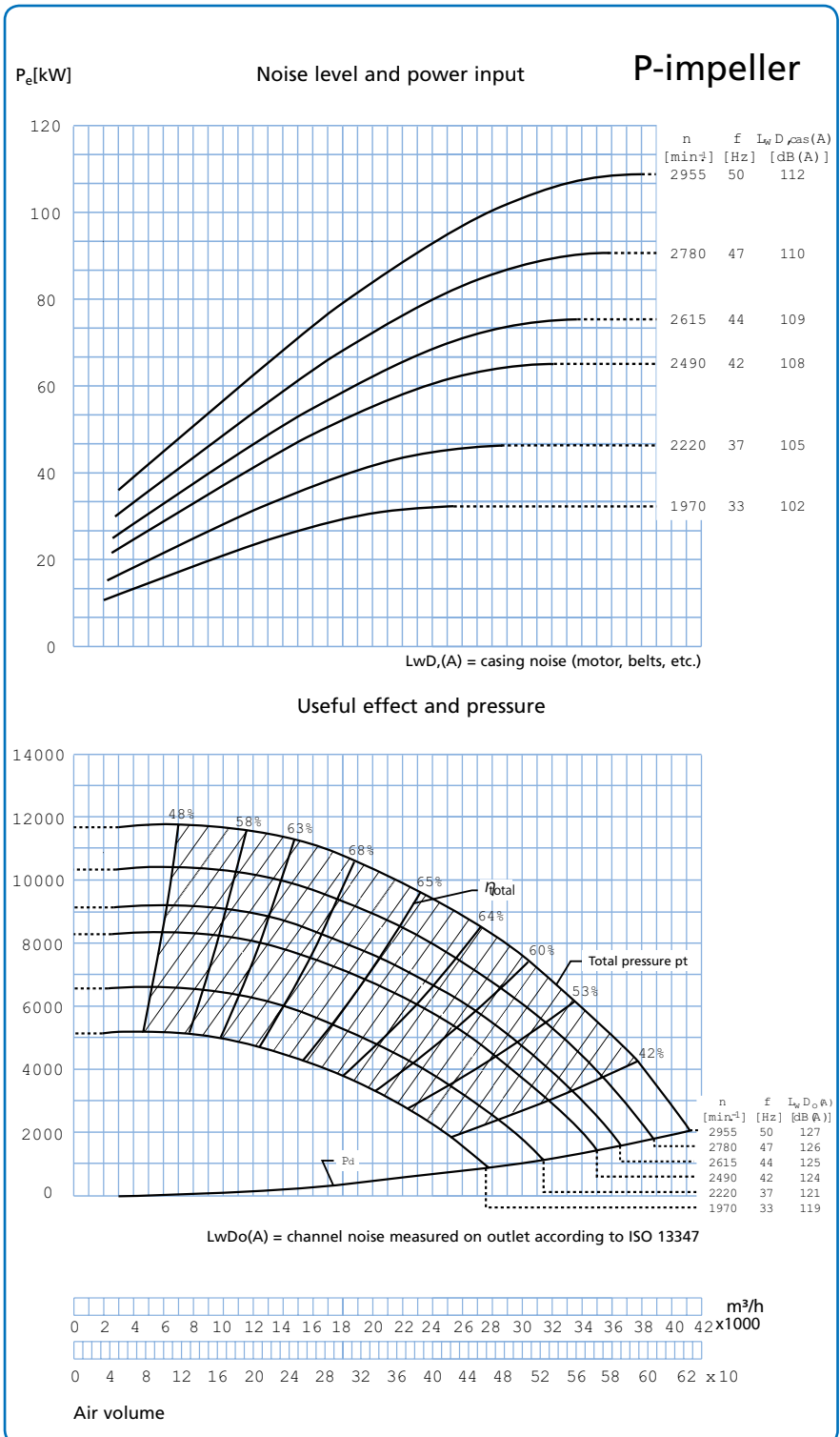

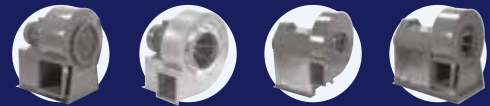

Fan types

MCD 30 – MCD 40 – MCD 50

The direct drive centrifugal fan types MCD 30, MCD 40 and MCD 50 are designed for transport of clean air.

Equipped with backward-inclined blades and aerodynamic intake.

The impellers are statically and dynamically balanced according to ISO 10816-3.

Normally, a frequency transformer is used to control the min^{-1} and the air volume of the fan.

Max. operating temperature: 60°C

The inlet (D) is supplied with flange as standard.

Specific dimensions for the outlet and inlet flanges can be found under “Flanges”.

Available in anti-spark version with stainless steel inlet and explosion proof (Ex) motor.

The technical data for each type appears on the following pages.

The blowers are as default delivered in position RV (LG270 according to Eurovent).

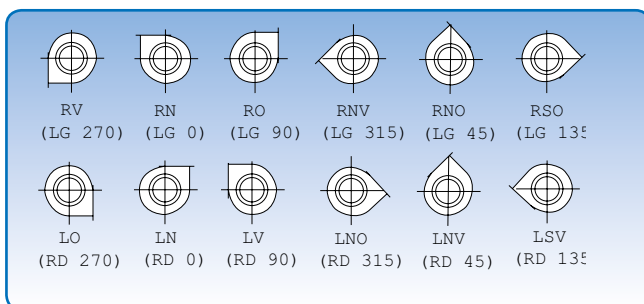
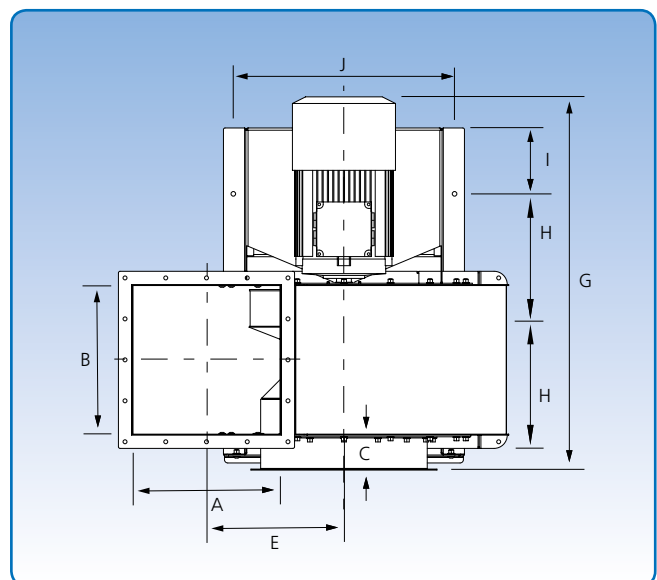
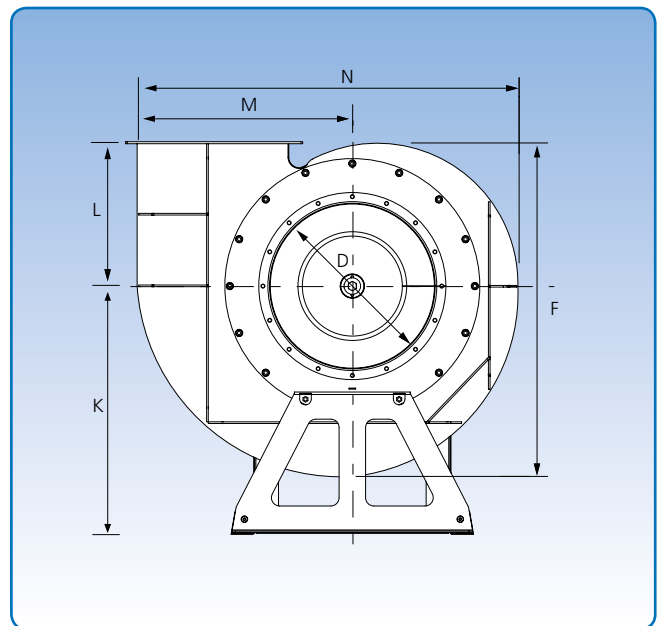

6 positions. The position illustrations are viewed from the inlet side.

Dimensions															Weight without motor kg
Type	A mm	B mm	C mm	D mm	E mm	F mm	G mm	H mm	I mm	J mm	K mm	L mm	M mm	N mm	
MCD 30	250	250	106	300	318	645	733	275	51	430	550	276	450	768	37
MCD 40	350	350	106	400	368	779	903	370	49	550	650	326	550	1098	119
MCD 50	450	450	106	500	416	1012	1128	370	199	672	750	436	643	1146	206



Fan type MCD 30

Technical data

Motor: IP 55

Supplied with the following motors:

50 Hz	60 Hz	amp.	Weight of motor kg
4,0 kW	4,8 kW	7,8	45
2880 min ⁻¹	3456 min ⁻¹		

Max. min⁻¹:

Impeller: 3,575 min⁻¹

Operating range:

Air volume: 2,000 – 6,000 m³/h

Pressure: 120 – 330 mm WG

Power supply:

230/400 V

Construction:

B3 – motor mounted on foot.

Variants:

Fan can be powered by flange motor –

Type B5/B14

Impeller:

No. of blades, standard: 6 pcs.

Diameter: ø424 mm

Height: 171 mm

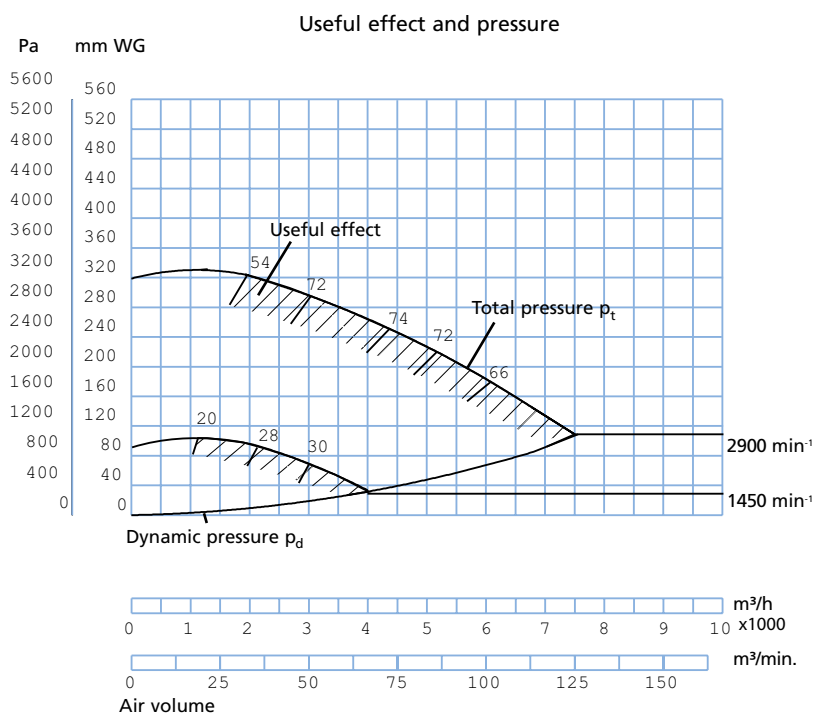
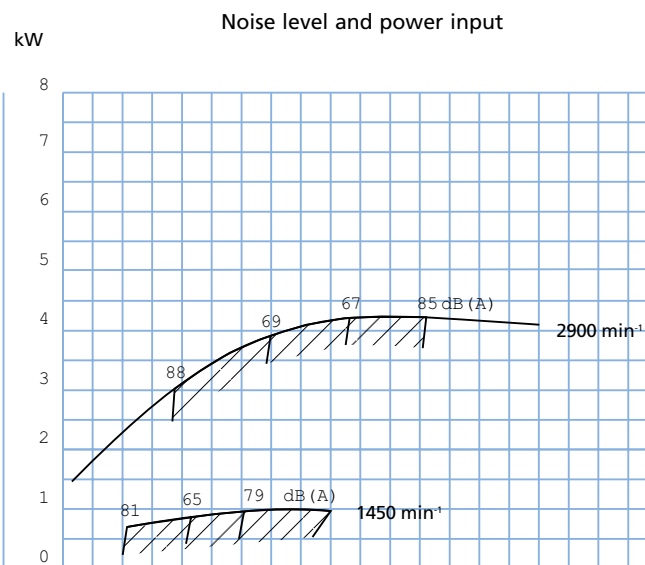

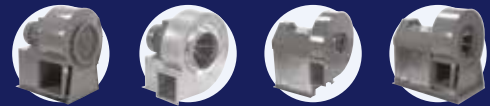

Fan type MCD 40

Technical data

Motor: IP 55

Supplied with the following motors:

50 Hz	60 Hz	amp.	Weight of motor kg
11 kW	13,2 kW	20,2	102
2940 min ⁻¹	3528 min ⁻¹		

Max. min⁻¹:

Impeller: 3,575 min⁻¹

Operating range:

Air volume: 2,500 – 14,000 m³/h

Pressure: 120 – 460 mm WG

Power supply:

400/690 V

Construction:

B3 – motor mounted on foot.

Impeller:

No. of blades, standard: 6 pcs.

Diameter: ø515 mm

Height: 196 mm

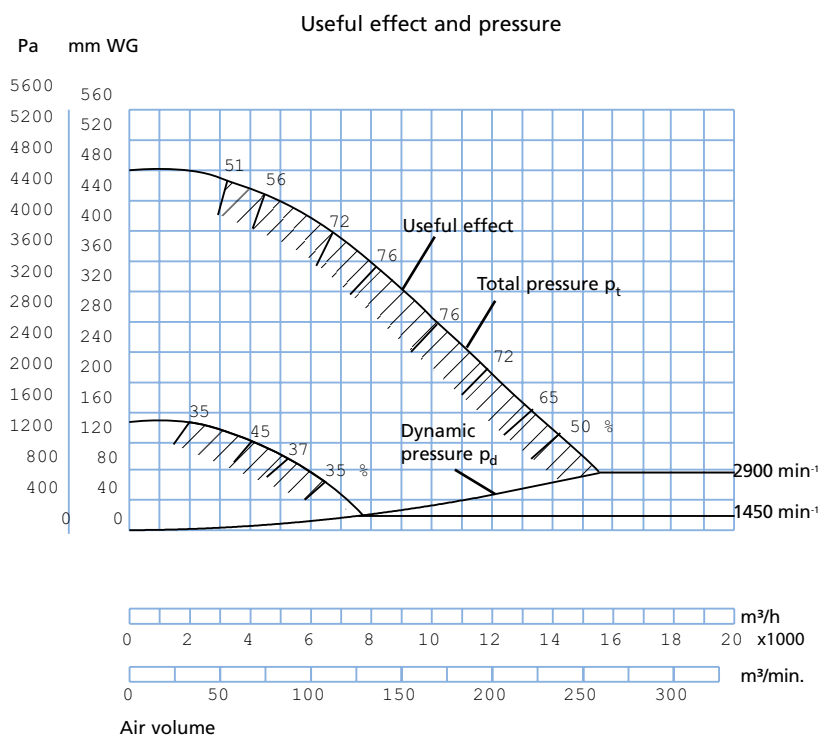
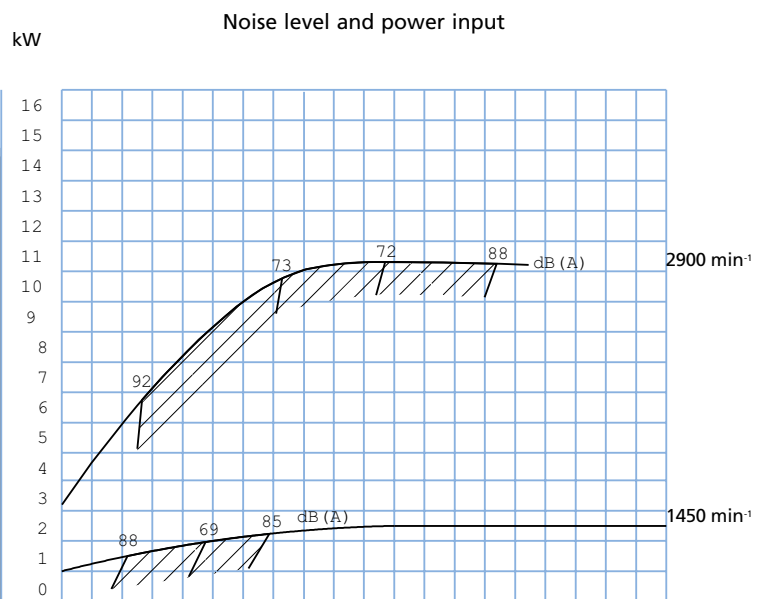

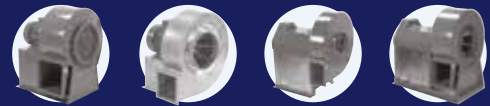

Fan type MCD 50

Technical data

Motor: IP 55

Supplied with the following motors:

50 Hz	60 Hz	amp.	Weight of motor kg
18,5 kW	22,2 kW	33,0	136
22,0 kW	26,4 kW	39,2	158
2940 min ⁻¹	3528 min ⁻¹		

Max. min⁻¹:

Impeller: 3,575 min⁻¹

Operating range:

Air volume: 2,500 – 22,000 m³/h

Pressure: 160 – 590 mm WG

Power supply:

400/690 V

Construction:

B3 – motor mounted on foot.

Impeller:

No. of blades, standard: 8 pcs.

Diameter: ø574/608 mm

Height: 227/224 mm

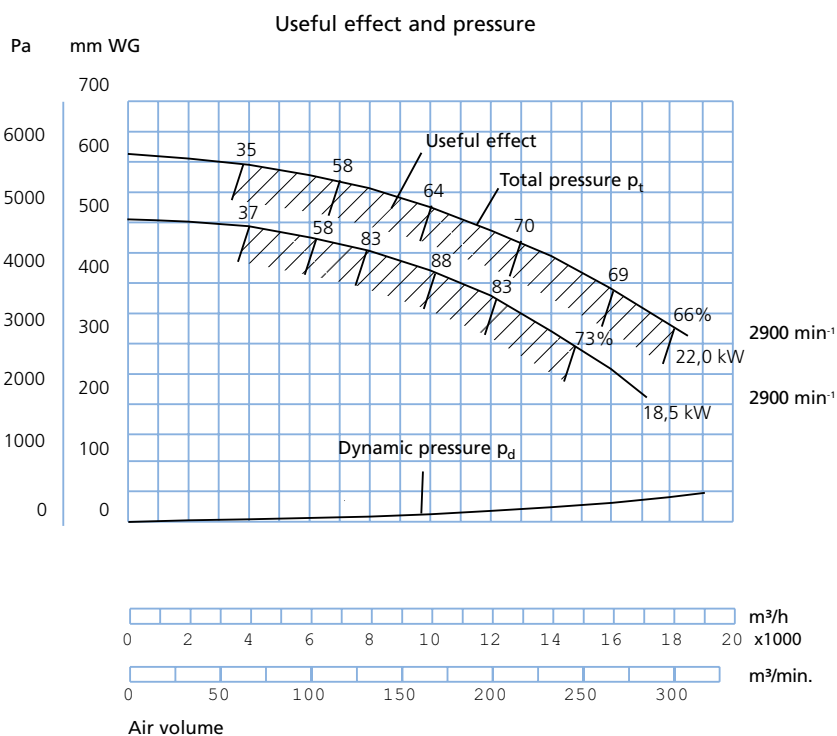
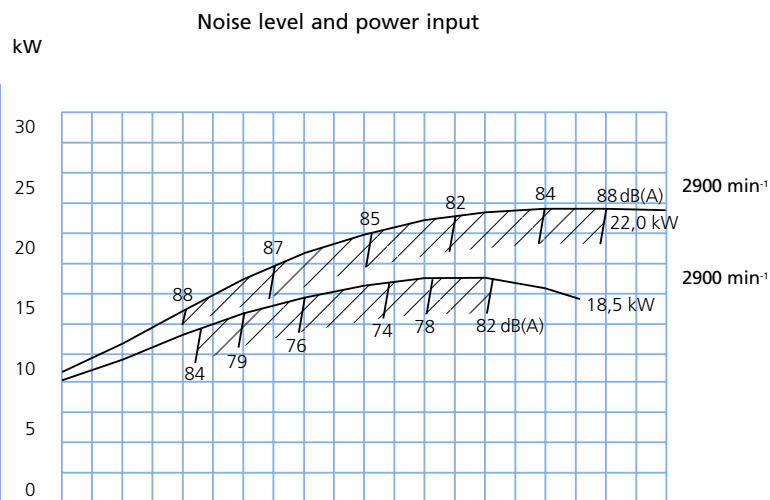



Fan types MCK 40 - MCK 100

The indirect drive centrifugal fan types MCK 40 - MCK 100 are designed for transport of clean air.

Equipped with self-cleaning impellers with backward-inclined blades and aerodynamic intake. The impellers are statically and dynamically balanced.

The pulleys are shaft-mounted with taperlock bushing, allowing easy replacement for changed fan speed.

Max. operating temperature: 60°C

With cooling wings: Up to 200°C

Available in anti-spark version with stainless steel inlet and explosion-proof (Eex) motor.

Dimensions (D) for the inlet are external. Supplied with flange as standard.

Belt drive is anti-static.

Specific dimensions for outlet and inlet flanges can be found under "Flanges".

The technical data for each type appears on the following pages.

The blowers are as default delivered in position RV (LG270 according to Eurovent).

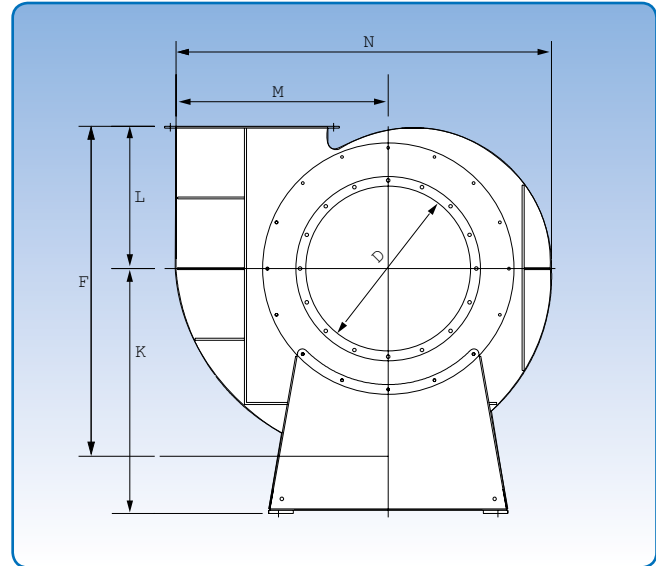

Steel plate dimensions in mm

Type	MCK 40/MCK 60	MCK 70/MCK 90	MCK 100
Impeller - standard	3	4	5
Fan housing - standard	3	3	3

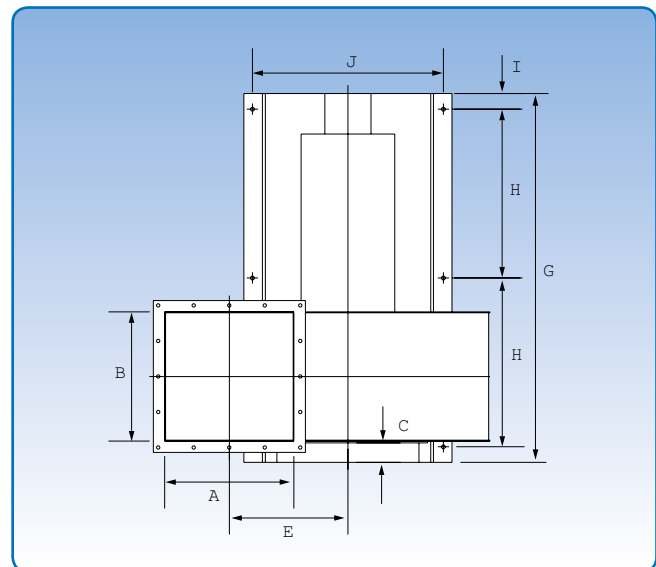
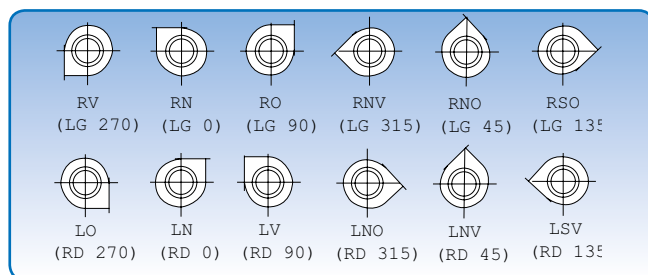

6 positions. The position illustrations are viewed from the inlet side.

Type	Dimensions														Weight without motor kg
	A mm	B mm	C mm	D mm	E mm	F mm	G mm	H mm	I mm	J mm	K mm	L mm	M mm	N mm	
MCK 40	350	350	75	400	368	775	1128	494	55	550	650	325	550	925	226
MCK 50	455	455	75	500	418	1000	1328	587	55	672	750	436	650	1150	343
MCK 60	505	505	75	600	543	1186	1563	700	59	825	955	486	800	1400	554
MCK 70	605	605	75	700	593	1360	1895	855	70	850	1125	566	900	1570	703
MCK 80	705	705	75	800	643	1490	1995	905	70	850	1125	625	1000	1727	788
MCK 90	805	805	75	900	723	1670	2310	1030	100	1070	1325	700	1130	1940	1189
MCK 100	905	905	75	1000	793	1865	2410	1080	100	1070	1425	770	1250	2175	1295

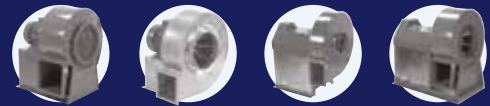

Fan type MCK 40

Technical data

Motor: IP 55

Supplied with the following motors:

kW	hp	amp.	Weight of motor kg
7,5	10,0	14,7	49
11,0	15,0	21,2	69
15,0	20,0	28,2	83
18,5	25,0	34,4	87

Max. min⁻¹:

Standard impeller: 3,435 min⁻¹

Operating range:

Air volume: 4,500 - 17,000 m³/h

Pressure: 100 - 450 mmWG

Power supply:

400 V - 50 Hz.

Construction:

B3 – motor mounted on foot.

Impeller:

No. of blades, standard: 6 pcs.

Diameter: ø515 mm

Højde: 196 mm

Noise level and power input

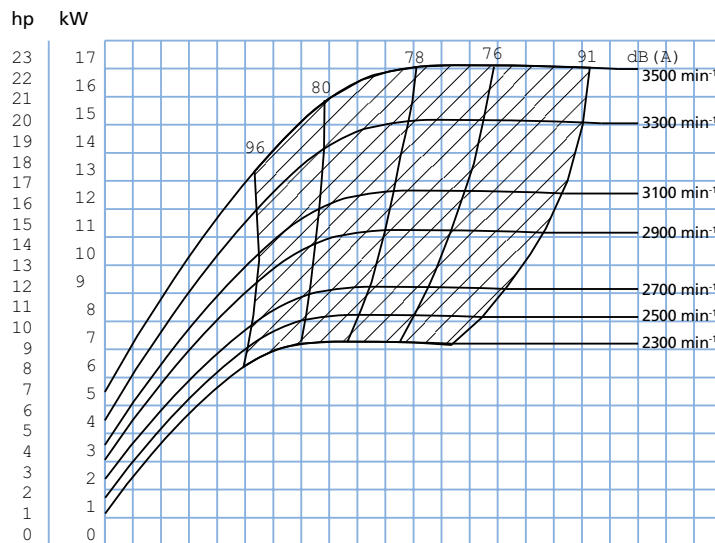

Useful effect and pressure

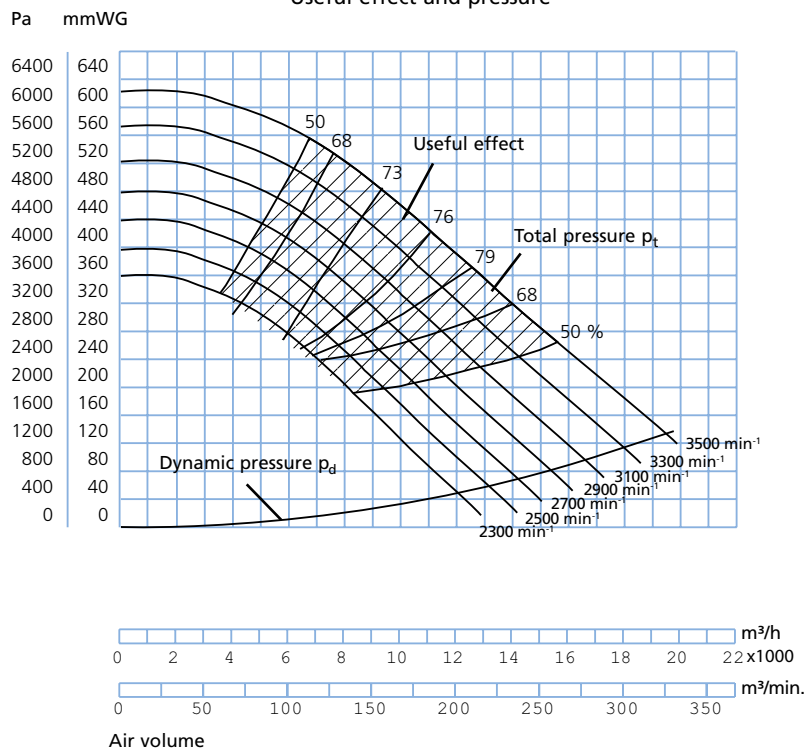

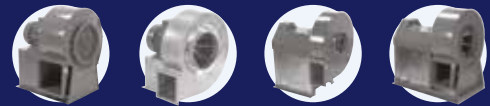

Fan type MCK 50

Technical data

Motor: IP 55

Supplied with the following motors:

kW	hp	amp.	Weight of motor kg
11,0	15,0	21,2	69
15,0	20,0	28,2	83
18,5	25,0	34,4	87
22,0	30,0	40,0	165
30,0	40,0	52,5	240

Max. min⁻¹:

Standard impeller: 2,450 min⁻¹

Operating range:

Air volume: 6,000 – 28,000 m³/h

Pressure: 120 – 520 mm WG

Power supply:

400 V - 50 Hz.

Construction:

B3 - motor mounted on foot.

Impeller:

No. of blades, standard: 8 pcs.

Diameter: ø705 mm

Height: 243 mm

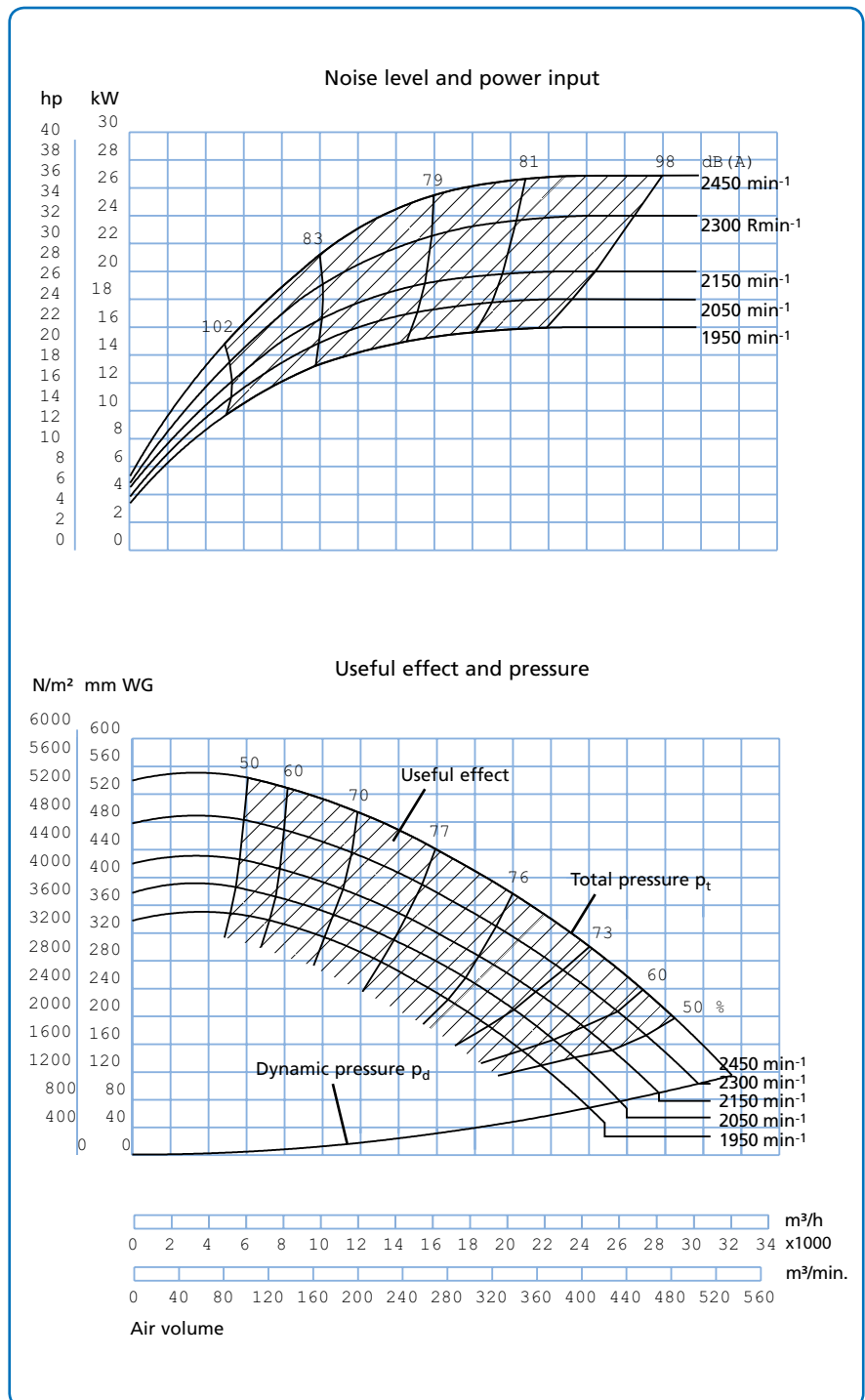



Fan type MCK 60

Technical data

Motor: IP 55

Supplied with the following motors:

kW	hp	amp.	Weight of motor kg
22,0	30,0	40,0	165
30,0	40,0	52,5	240
37,0	50,0	67,0	300
45,0	62,0	80,0	330

Max. min⁻¹:

Standard impeller: 2,350 min⁻¹

Operating range:

Air volume: 9,000 – 39,000 m³/h

Pressure: 160 – 600 mm WG

Power supply:

400 V - 50 Hz.

Construction:

B3 - motor mounted on foot.

Impeller:

No. of blades, standard: 8 pcs.

Diameter: ø805 mm

Height: 285 mm

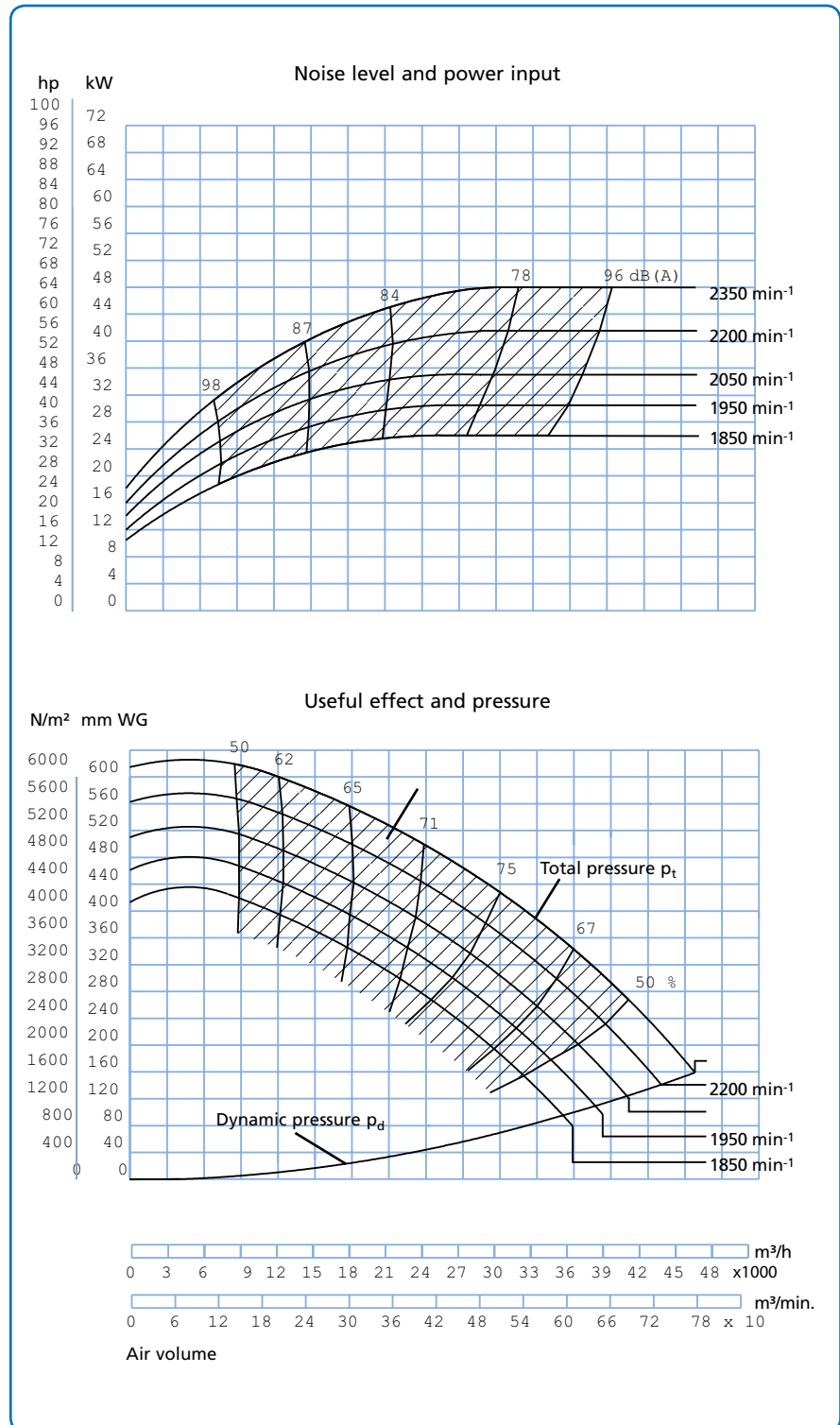



Fan type MCK 70

Technical data

Motor: IP 55

Supplied with the following motors:

kW	hp	amp.	Weight of motor kg
30,0	41,0	53,0	230
37,0	50,0	67,0	300
45,0	62,0	80,0	330
55,0	75,0	97,0	435
75,5	103,0	133,0	610

Max. min⁻¹:

Standard impeller: 2,050 min⁻¹

Operating range:

Air volume: 12,000 – 54,000 m³/h

Pressure: 150 – 600 mm WG

Power supply:

400 V - 50 Hz.

Construction:

B3 - motor mounted on foot.

Impeller:

No. of blades, standard: 8 pcs.

Diameter: ø905 mm

Height: 315 mm

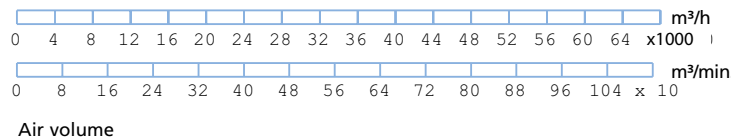
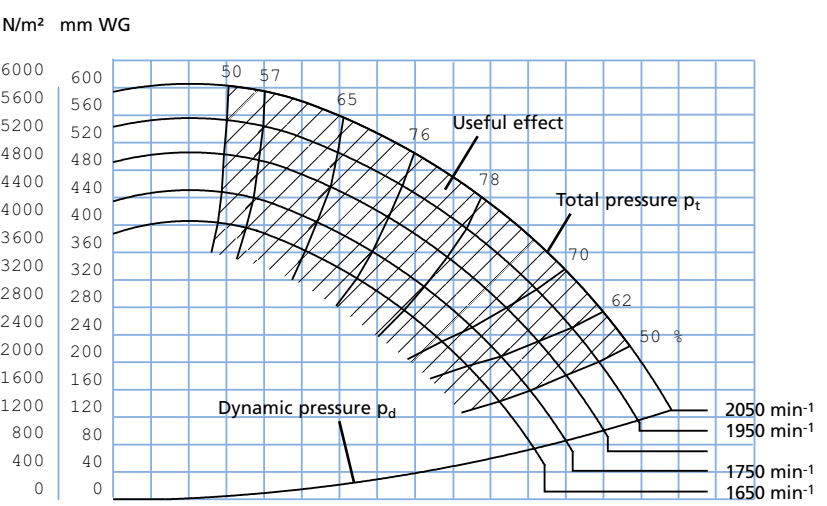
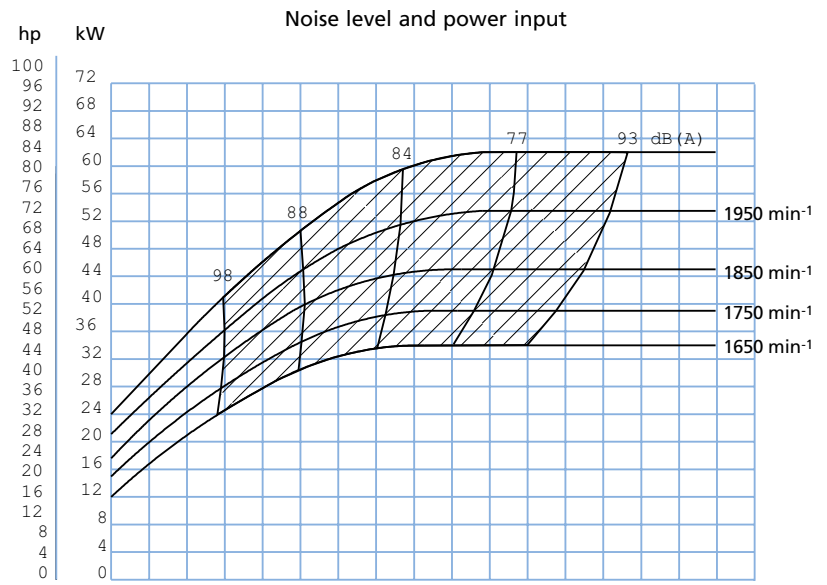



Fan type MCK 80

Technical data

Motor: IP 55

Supplied with the following motors:

kW	hp	amp.	Weight of motor kg
37,0	50,0	67,0	300
45,0	62,0	80,0	330
55,0	75,0	97,0	435
75,5	103,0	133,0	610
90,0	123,0	159,0	660

Max. min⁻¹:

Standard impeller: 1,850 min⁻¹

Operating range:

Air volume: 16,000 – 64,000 m³/h

Pressure: 160 – 560 mm WG

Power supply:

400 V - 50 Hz.

Construction:

B3 - motor mounted on foot.

Impeller:

No. of blades, standard: 8 pcs.

Diameter: \varnothing 1007 mm

Height: 357 mm

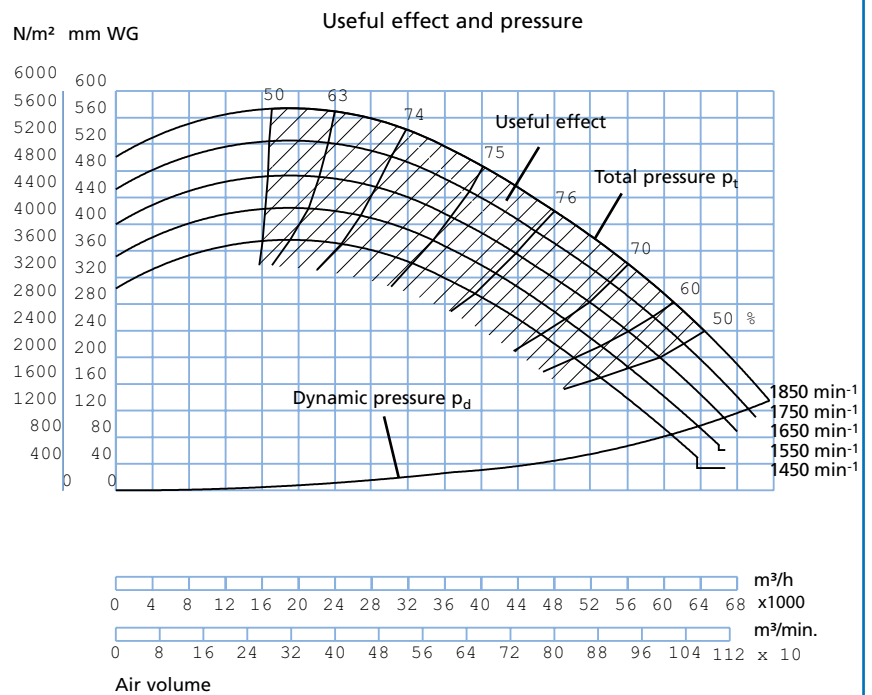
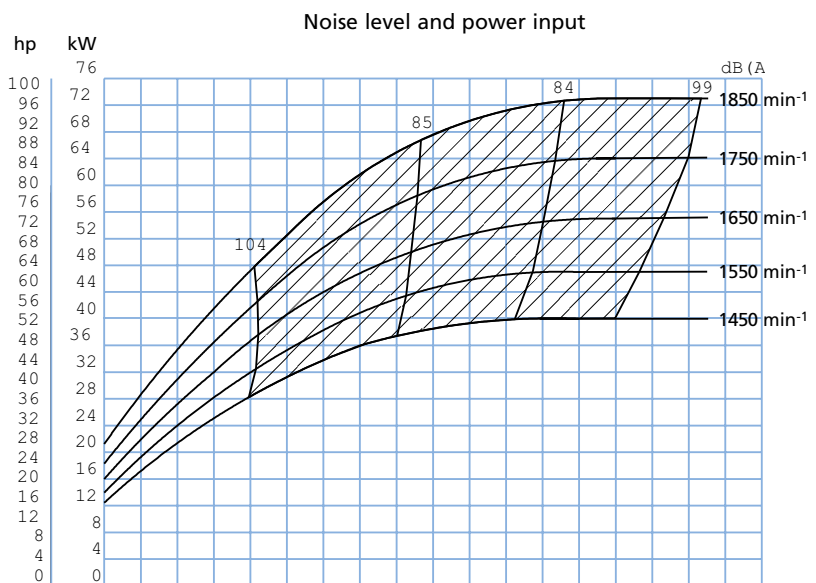

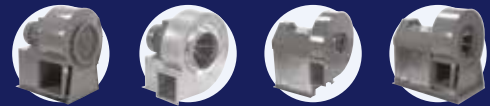

Fan type MCK 90

Technical data

Motor: IP 55

Supplied with the following motors:

kW	hp	amp.	Weight of motor kg
45,0	62,0	80,0	330
55,0	75,0	97,0	435
75,5	103,0	133,0	610
90,0	123,0	159,0	660
110,0	151,0	195,0	830

Max. min⁻¹:

Standard impeller: 1,650 min⁻¹

Operating range:

Air volume: 25,000 – 80,000 m³/h

Pressure: 150 – 560 mm WG

Power supply:

400 V - 50 Hz.

Construction:

B3 - motor mounted on foot.

Impeller:

No. of blades, standard: 8 pcs.

Diameter: ø1127 mm

Height: 417 mm

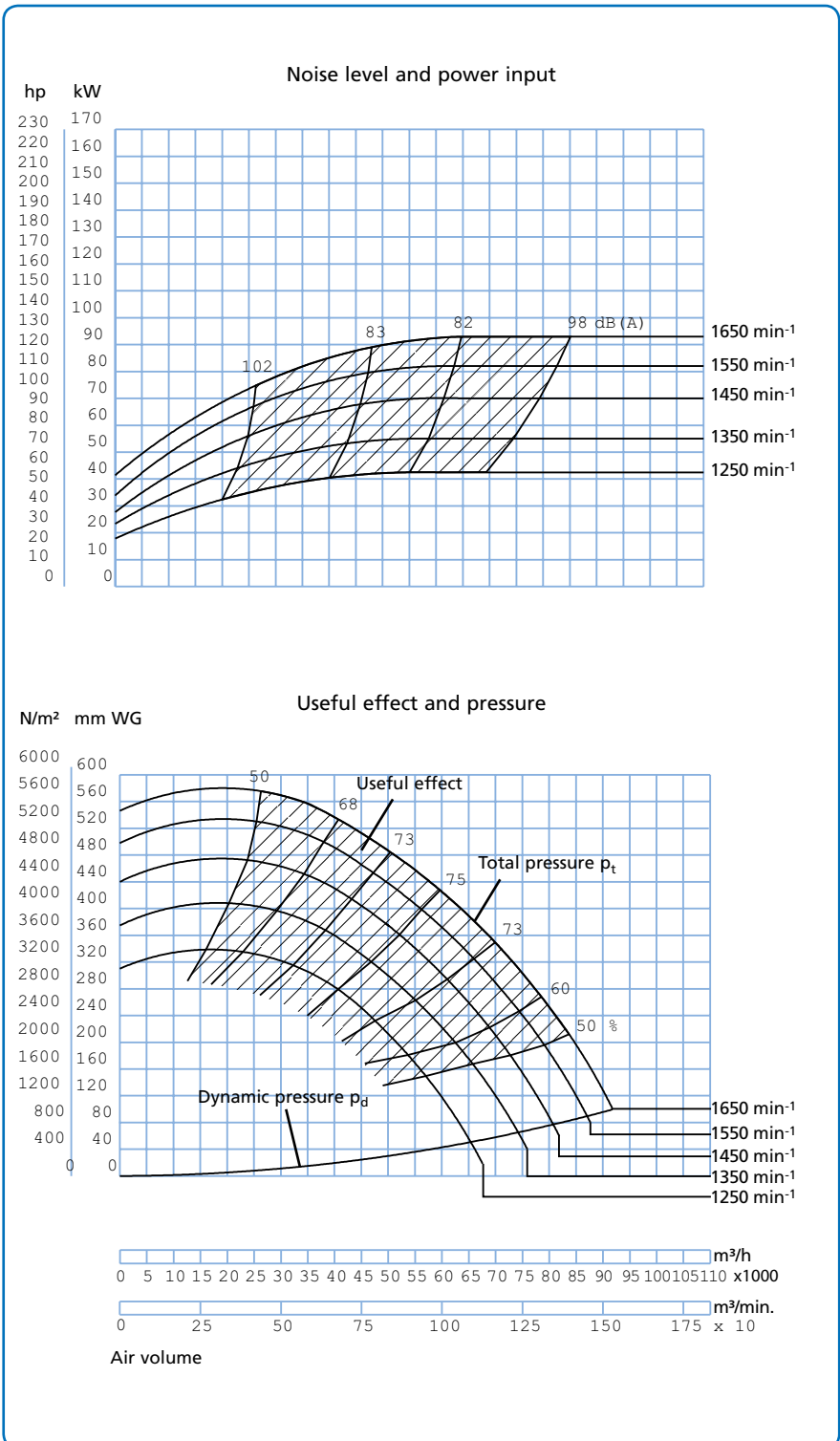

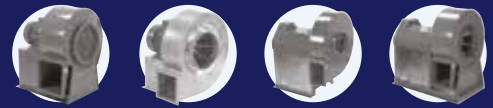

Fan type MCK 100

Technical data

Motor: IP 55

Supplied with the following motors:

kW	hp	amp.	Weight of motor kg
55,0	75,0	97,0	435
75,5	103,0	133,0	610
90,0	123,0	159,0	660
110,0	151,0	195,0	830
132,0	180,0	232,0	910

Max. min⁻¹:

Standard impeller: 1,550 min⁻¹

Operating range:

Air volume: 25,000 – 115,000 m³/h

Pressure: 140 – 600 mm WG

Power supply:

400 V - 50 Hz.

Construction:

B3 - motor mounted on foot.

Impeller:

No. of blades, standard: 8 pcs.

Diameter: ø1257 mm

Height: 484 mm

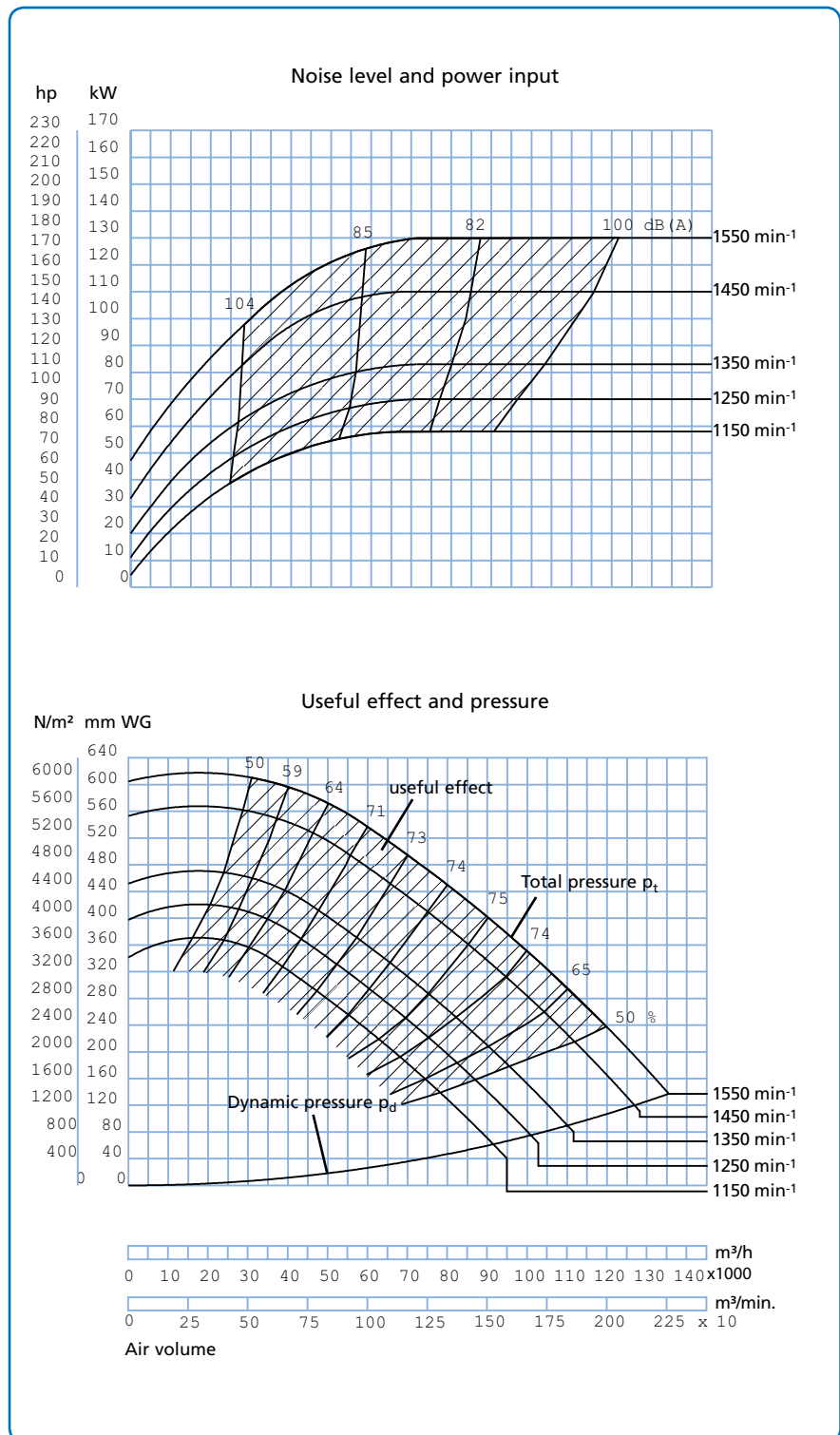



Acoustic booths type AB

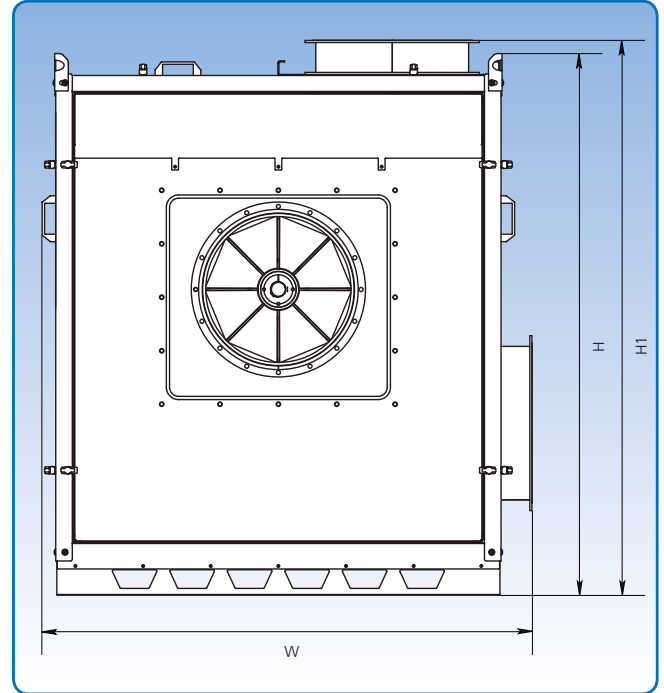
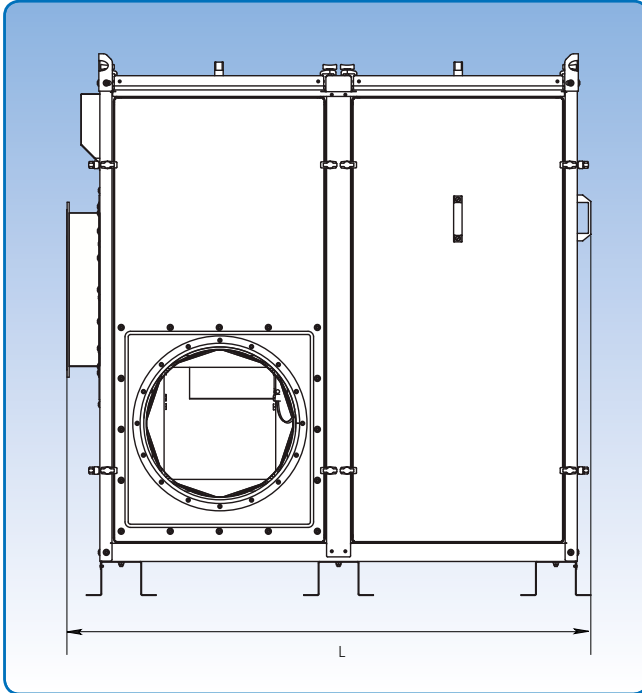

For dimensional specifications, see below.

The type AB acoustic booths are used for noise reduction. The acoustic booths are supplied with fitted fan or in kit form. The acoustic booth is as standard supplied with rotatable flange fitted on in- and outlet. This provides easy connection to the remaining ducting. Acoustic booths are supplied with same dimension of inlet and outlet flange as the fan.

Acoustic booths are assembled by means of clamps that hold the big panels to the steel frame.

At service/inspection you can then quickly remove the sides and have easy access to the fan. The panels are provided with handle for easy handling. The panels tighten with rubber strip against the frame. Noise and vibrations are in this way reduced. Acoustic booths are made from galvanized sheet (Z275).

The damping material is an environment friendly material, made from recycling material from polyethylene production, covered with foil and fire resistant material.

The acoustic booth is as standard supplied with cooling fan fitted in bottom, for optimum cooling.

Extras

The acoustic booths are supplied with light fixture to the ceiling lights, thermostat control for cooling fan and connection box for assembly of cables as extras.

Type	Dimensions			Weight kg
	L mm	W mm	H(H1) mm	
AB-20	990	1133	1265 (1305)	139
AB-30	1410	1315	1460 (1499)	198
AB-40	1549	1453	1595 (1633)	252
AB-50	2140	1823	2247	501
AB-60	2500	2071	2477	644
AB-70	2871	2262	2549	871
AB-80	3075	2615	2884	970
AB-85	3075	2615	3135	1013

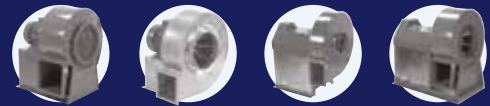

Acoustic booths type AB

Technical data

Cooling fan is fitted in a sound absorbent box with washable intake filter.

Cooling fan type 4656 Z:

Power supply 230 V, 50/60 Hz

at 230 V, 18 W, 0,1 A

For use with max. 5,5 kW electric motor

For use with type AB-20 and AB-30 acoustic booth

Cooling fan type W 2 E 200 HH 38-05:

Power supply 230 V, 50/60 Hz or 230/400 V, 50/60 Hz

at 230 V, 80 W, 0,35 A

For use with 7,5 – 22 kW electric motor

For use with type AB-30 – AB-50 acoustic booth

Cooling fan type W 2 E 250 HL 06-01:

Power supply 230 V, 50/60 Hz or 230/400 V, 50/60 Hz

at 230 V, 127 W, 0,83 A

For use with 30 – 90 kW electric motor

For use with type AB-50 – AB-85 acoustic booth

Noise reduction

The diagram shows the noise-suppression values for fans in acoustic booth.

Individual reports for each combination of fan and acoustic booth can be provided.

Noise measurement made by DELTA.

Fan	Position		
	RV, LO	RN, LN	RO, LV
MTD 20	AB-20	AB-20	AB-20
MTD 22	AB-20	AB-20	AB-20
MTD 25	AB-20	AB-20	AB-20
MTD 30	AB-20	AB-20	AB-20
MTD 35	AB-30	AB-30	AB-30
MTD 40	AB-30	AB-30	AB-30
MTK 40	AB-40	AB-40	AB-40
MTK 45	AB-40	AB-40	AB-50*
MTK 55	AB-50	AB-50	AB-50
MTK 75	AB-60	AB-60	AB-60
BTD/BTK/BPD/BPK 200	AB-40	AB-40	AB-40
BTD/BTK/BPD/BPK 300	AB-50	AB-50	AB-50
BTD/BTK/BPD/BPK 400	AB-50	AB-50	AB-50
BTD/BTK/BPD/BPK 500	AB-60	AB-60	AB-60
MCD 30	AB-30	AB-30	AB-30
MCD 40	AB-30	AB-30	AB-40*
MCD 50	AB-50	AB-50	AB-50
MCK 40	AB-40	AB-40	AB-40
MCK 50	AB-50	AB-50	AB-50
MCK 60	AB-50	AB-50	AB-50
MCK 70	AB-60	AB-60	AB-60

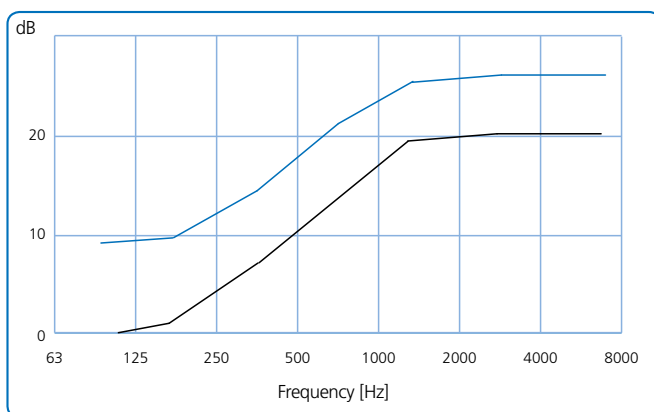

Black diagram shows general damping values for fans in acoustic booth. Blue diagram shows equivalent damping values, when structure borne noise from fan and acoustic booth is not transmitted.

Choice of acoustic booth:

L after fan description indicates long version with guide vane.

* The fan can with alternative position, be installed in a smaller acoustic booth.

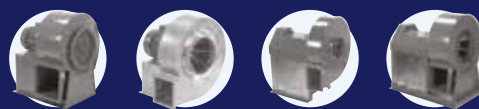

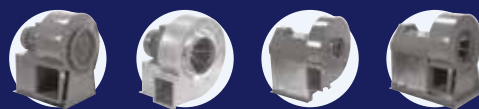

Kongskilde industries A/S
Tel. +45 33 68 37 00
mail@kongskilde.com
www.kongskilde.com

