



# CONCRETE CRUSHER

# CC430

25 - 30 % higher productivity rate compared to CC420

## Compact and powerful!

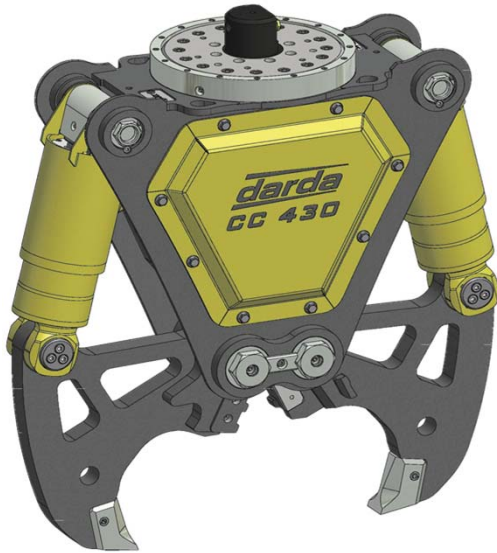

### Technical Data

Dimensions		
Length x width x height <sup>1</sup>	896 x 843 x 330 mm	35 x 33 x 13 in
Opening width	431 mm	17 in
Weight		
Total weight <sup>1</sup>	240 kg	530 lbs
Device carrier weight	2.5 - 4.8 t	5510 - 10580 lbs
Hydraulic connection		
Pressure max.	500 bar	7300 psi
Oil flow max.	100 l/min	27 gal/min
Performance		
Crushing force A max.	382 kN (38 t)	85900 lb
Crushing force B max.	509.2 kN (51.9 t)	114400 lb
Crushing force C max.	675.3 kN (68.8 t)	151700 lb
Cutting capacity max.	1x Ø30 mm	1x Ø1 1/8 in

<sup>1</sup> Value without support plate

Mounting plates of different carriers on request



Crusher with standard tips

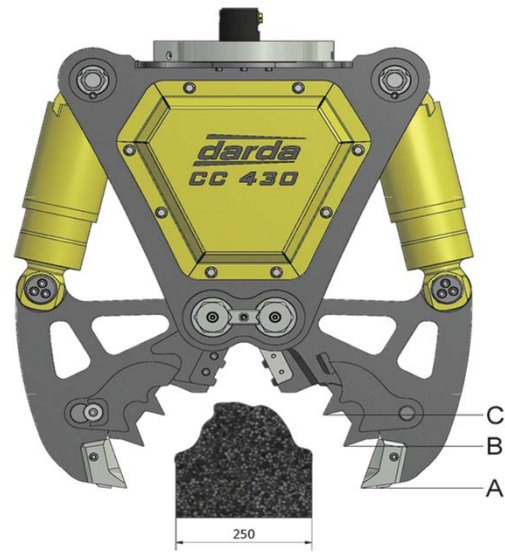

Crusher with additional teeth



*We've got the power.*

Darda GmbH  
 Im Tal 1, D-78176 Blumberg  
 Fon + 49 (0) 77 02 / 43 91 - 0  
 Fax + 49 (0) 77 02 / 43 91 - 12  
 info@darda.de  
 www.darda.de

Our distributor:

