

Standard Equipment

- Bowls
- Drive Units
- Control Boxes
- Accessories

Vibratory Bowl Feeders

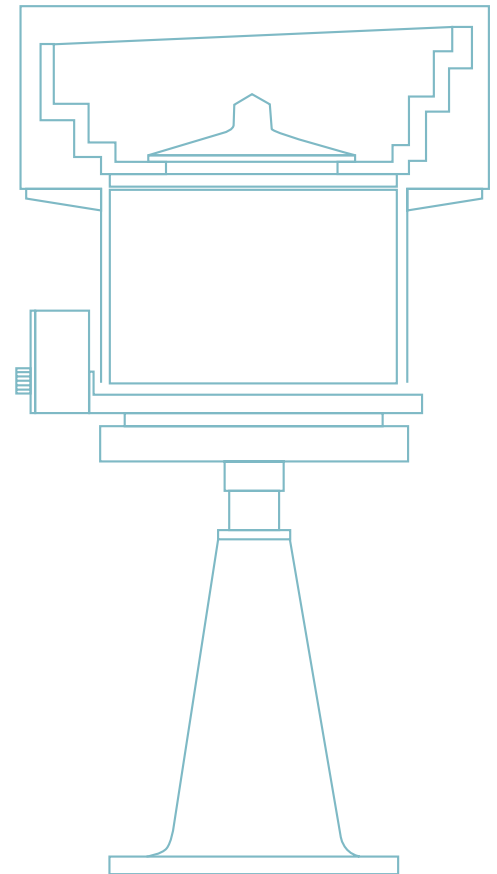

RNA – Feeding Technology



RNA – The Company

With many years experience in the parts handling industry and nearly 2000 complete feed systems supplied annually, RNA have earned a reputation for the most robust and reliable equipment on the market. Our commitment to research and development maintains our position at the leading edge of feeding technology.

We provide an extensive range of the most efficient drive units, controllers and accessories for either standard or special requirements. All equipment is manufactured to the highest standards of quality upon which we have built our reputation.

We offer a first class service and for standard equipment, immediate delivery from stock. Our product range is manufactured to meet the highest demands of the food and pharmaceutical industries and also includes equipment manufactured to UL and CSA standards.

Quality has always been of central importance to RNA, with each employee committed to make their own personal contribution to the achieve-

ment of quality standards and customer satisfaction. We know that long term success in business can only be achieved by providing high quality equipment, which fulfils the customers requirements.



The Catalogue

This catalogue represents our complete range of standard equipment.

It includes drive units, bowls, bowl centres, control boxes and additional accessories including stands, base plates, sound covers and sensors. Special requirements are available upon request.

We also manufacture tooling to orientate components, which together with our standard equipment, provides a system ready to integrate with a customer's machine.

If you require bespoke tooling, please complete the enquiry form on page 23 of this catalogue. Send this together with your specification and bulk components and we will be happy to provide you with a detailed quotation.

This catalogue has been designed to provide technical details on many of our standard products.

Please refer to the guidance notes on the following pages.

For those who are familiar with our brochure, you will find a summary table showing all equipment and the construction sizes on page 23-1. Further technical information can be found on our web sites www.rna-uk.com and www.rna.de

Contents

Subject	see page
RNA – The company	2
Equipment catalogue	3
How to use the catalogue	4
1 Bowls	6
2 Bowl centres	13
3 Drive units	14
4 Control boxes	16
Bowl coatings	18
5 Base plates	19
Sensors	20
6 Stands and	
7 top plates	21
8 Soundproof covers	22
Enquiry form	23
Product overview and reference codes	23-1

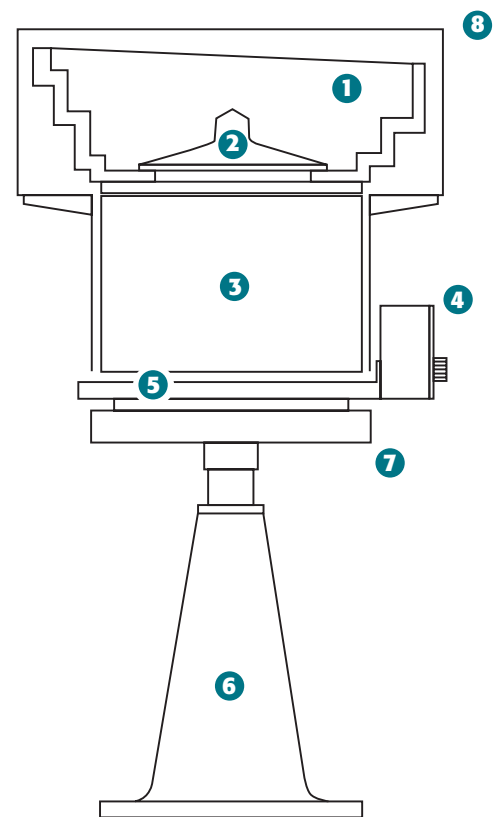

More product catalogues from the RNA range of equipment

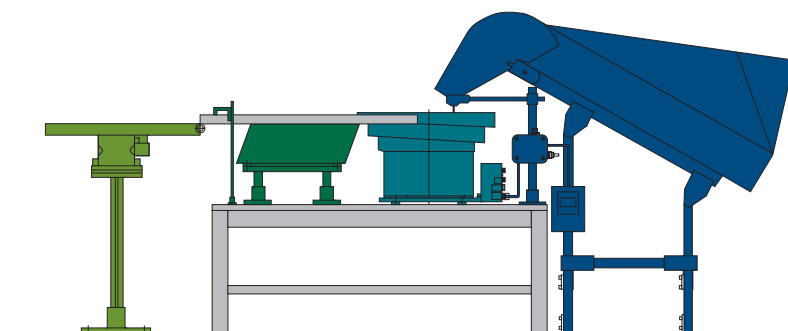

Colouring of catalogues:

- Bulk hopper
- Linear feeder
- Conveyor



How to use this catalogue

We suggest the following sequence:

1. Selection of bowl type
(cylindrical, conical, stepped)
according to the table given below.



Bowl

Cylindrical bowl

Suitable for

Continuous transport of components and for handling small parts

Page

Page 6



Conical bowl

Heavy sharp-edged components
Larger Loads
Automatic pre-separating

Page 8

Type RG

Ideal for the food and pharmaceutical industry

Page 8



Stepped bowl

Larger loads and larger components
see also conical bowls

Page 10

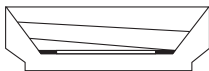

Polyamide bowls
(conical or stepped)

Small components with simple geometry and where mass production of feeders is required

Page 12

Technical data is subject to change. All measurements are stated in mm.

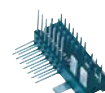

2. Dependant upon the application, you can define the bowl size by choosing the track width measurement (B).

Each bowl has a dedicated drive unit. For ease of machine assembly we recommend the use of a base plate.

Please use the code for enquiries and orders. (For codes refer to page 23-1)

Type	TAG-Z 200(324)-20-105	TAG-N 25	TAG-Z 200-10-80	TAG-N 250-32-145	TAG-ZA 250-32-165
Capacity [l]*	1	1	0.5	2	2
Material	Aluminium	Aluminium	Aluminium	Aluminium	Aluminium
A = Discharge height	75	78	93	112	132
B = Width of track	20	20	32	32	32
C = Discharge radius	166	168	206	206	206
H = Bowl height	330	330	400	400	400
H = Discharge height	80	97	101	124	145
S = Track pitch	20	32	34	42	42+15**
Bowl weight	0.8	2.6	1.65	3.4	6.9
Fixing	central	central	radial	radial	central
Bottom (see page 13)	cast	cast	required	required	cast
Suitable drive unit	SRC-N 200	SRC-B 200	SRC-N 200	SRC-N 250	SRC-N 250
(see also page 14)					
Z = Total discharge height	252	263	323	357	357
Suitable base plate	SRG-N 200	SRG-N 200	SRG-N 200	SRG-N 250	SRG-N 250
(see also page 19)					

3. Please state the feed direction for orders of bowls and drive units.

- 1) Left handed: anti-clockwise
- 2) Right handed: clockwise

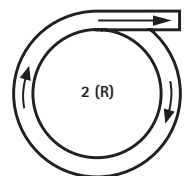
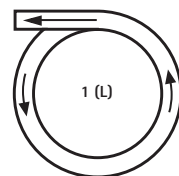

Cylindrical Bowls

These bowls provide a constant feed of components. They are ideal for small components, but have restricted capacity for some applications.

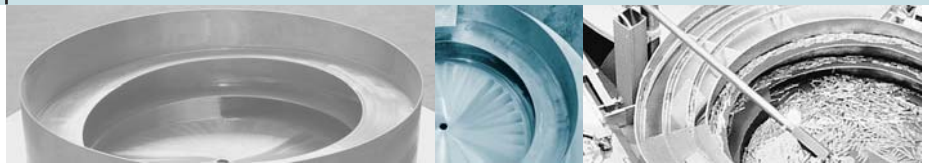

Type	ZAD-Z 63-4-18	ZAD-Z 100-6-50	ZSD-Z 160-12-70	ZSB-Z 160-12-70	ZSB-Z 200-12-80	ZSB-N 250-30-110
Capacity [l]*	0.05	0.2	0.5	0.5	0.8	1.6
Material	Aluminium	Aluminium	Steel	Stainless Steel	Stainless Steel	Stainless Steel
A = Discharge height	17	35	64	64	65	100
B = Width of track	5	6	12	12	12	30
D = Bowl diameter	70	100	168	168	181	288
H = Height of bowl	18	40	70	70	80	110
S = Track pitch	8	12	22	22	22	35
Bowl weight	0.09	0.3	1.4	1.1	1.35	4.2
Fixing	central	central	central	central	central	radial
Bottom (see page 13)	integral	integral	integral	fully welded	fully welded	required
Suitable drive unit	SRC-N 63	SRC-N 100	SRC-N 160	SRC-N 160	SRC-N 200	SRC-N 250
(see also page 14)						
Z = Total discharge height	82	117	220	220	253	345
Suitable base plate	-	-	SRG-N 160	SRG-N 160	SRG-N 200	SRG-N 250
(see also page 19)						

* Larger capacities available, dependent on application and components

** Each track pitch increased by 3 mm



Cylindrical Bowls

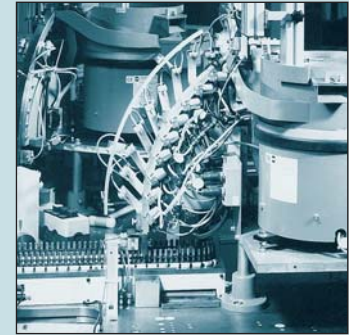
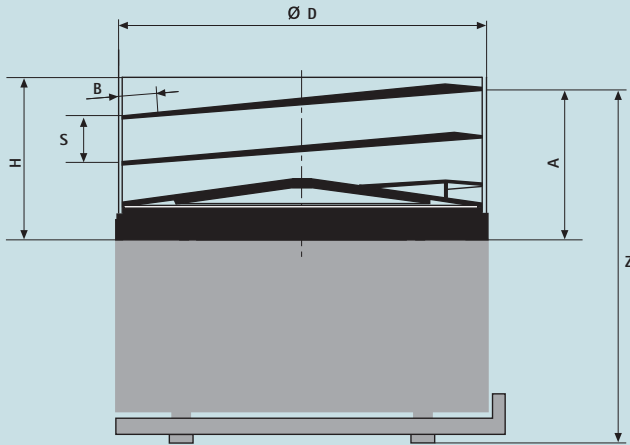

Please advise feed direction when ordering (see also page 5).

ZSB-ZA 250-30-125	ZSB-N 400-30-160	ZSB-BA 400-30-175	ZSB-Z2A 400-30-190	ZSB-N 630-50-180	ZSB-BA 630-50-195	ZSB-B 800-80-220
1.6	7	7	7	20	20	20
Stainless Steel	Stainless Steel	Stainless Steel	Stainless Steel	Stainless Steel	Stainless Steel	Stainless Steel
120	141	155	172	156	167	195
30	30	30	30	50	50	80
288	440	440	440	670	670	820
125	160	175	191	180	195	220
33**	50	50	50	70	70	70
6.4	8.4	10.6	16.3	16.2	18.7	36.8
central	radial	radial	central	radial	radial	radial
fully welded	required	fully welded	fully welded	required	fully welded	fully welded
SRC-N 250	SRC-N 400 SRHL 400	SRC-N 400 SRHL 400	SRC-N 400 SRHL 400	SRC-N 630	SRC-N 630	SRC-N 800
365	401(SRC-N) 422(SRHL)	415(SRC-N) 436(SRHL)	432(SRC-N) 453(SRHL)	415	426	510
SRG-N 250	SRG-N 400	SRG-N 400	SRG-N 400	SRG-N 630	SRG-N 630	-

The measurements mentioned above are valid for standard equipment only without tooled devices.
Subject to manufacturing tolerances.

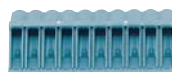

Conical Bowls

A conical bowl provides a higher capacity and with an increase in radius, assists with the pre-singulation of components.

Where necessary, the standard track width, track pitch and the amount of tracks can be adapted to suit the application.

Type RG makes pre-orientation possible through a sloping track position which prevents parts jamming between the pitch of the tracks.

The closed track type is particularly suitable for pharmaceutical applications.

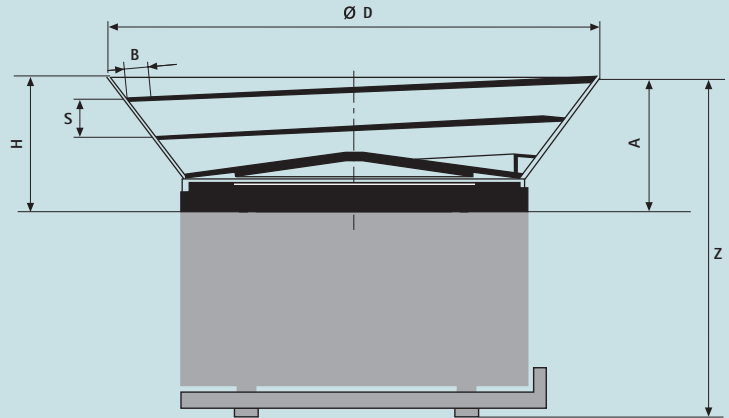

Type	KAD-Z 63-4-30	KAD-Z 100-4-40	KSB-Z 200-18-55	KSB-N 250-20-90	KSB-ZA 250-20-105
RG Range			KSB-Z 200-5RG-60		
Capacity [l]*	0.04	0.15	0.5	2	2
Material	Aluminium	Aluminium	Stainless Steel	Stainless Steel	Stainless Steel
A = Track discharge height	25	35	47	77	111
RG Range			50		
B = Track width	4	4	18	20	20
RG Range			5		
D = Bowl diameter	69	99	265	403	415
RG Range			277		
H = Bowl height	30	40	55	90	115
RG Range			60		
S = Track pitch	6.5	11	25	32	32
RG Range			28		
Bowl weight	0.11	0.34	1.46 1.7	3.85	8.2
Fixing	central	central	central	radial	central
Bottom (see page 13)	integral	integral	welded	required	welded
Suitable drive unit	SRC-N 63	SRC-N 100	SRC-N 200	SRC-N 250	SRC-N 250
(see also page 14)					
Z = Total discharge height	90	117	235	322	356
RG Range			238		
Suitable base plate	-	-	SRG-N 200	SRG-N 250	SRG-N 250
(see also page 19)					

* Larger capacities available, dependent on application and components



Conical Bowls

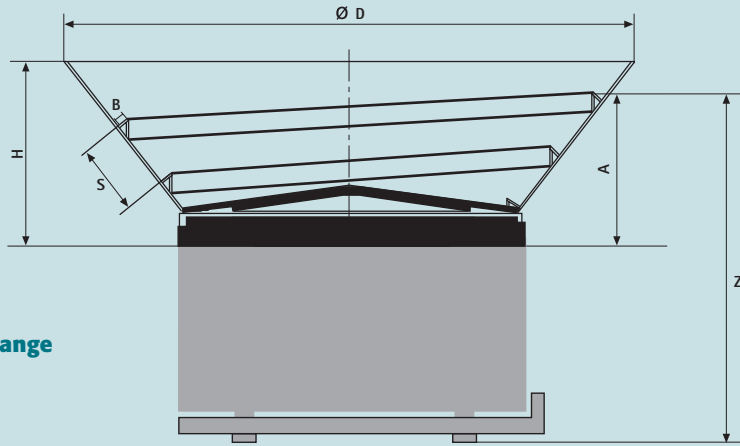

RG Range



Please advise feed direction when ordering (see also page 5).

KSB-ZA 250-20-150	KSB-N 400-50-160	KSB-BA 400-50-175	KSB-Z2A 400-50-190	KSB-N 630-50-180	KSB-BA 630-50-190	KSB-B 800-80-170
KSB-ZA 250-8RG-150		KSB-BA 400-15RG-220	KSB-Z2A 400-15RG-235		KSB-BA 630-15RG-250	
2	10	10	10	20	20	25
Stainless Steel	Stainless Steel	Stainless Steel	Stainless Steel	Stainless Steel	Stainless Steel	Stainless Steel
135	153	166	180	172	167	148
138		169	185		149	
20	50	50	50	50	50	80
8		15	15		15	
476	670	670	670	898	898	1200
478		745	745		980	
150	160	175	190	180	190	170
-		220	235		250	
32	68	68	68	70	70	64
40		71	71		81	
9.2	12.9	13.6	19.4	19	21.5	35
10.8		16	23.2		27	
central	radial	radial	central	radial	radial	radial
welded	required	welded	welded	required	welded	welded
SRC-N 250	SRC-N 400	SRC-N 400	SRC-N 400	SRC-N 630	SRC-N 630	SRC-N 800
	SRHL 400	SRHL 400	SRHL 400			
380	413(SRC-N) 434(SRHL)	426(SRC-N) 429(SRHL)	440(SRC-N) 445(SRHL)	431	426	463
383		447(SRC-N) 450(SRHL)			408	
SRG-N 250	SRG-N 400	SRG-N 400	SRG-N 400	SRG-N 630	SRG-N 630	-

The measurements mentioned above are valid for standard equipment only without tooled devices. Subject to manufacturing tolerances.



Stepped Bowl

Stepped bowls have a larger feeding track width and are particularly suited to pre-orientation of components. The capacity is larger than that of a cylindrical bowl. A further advantage is that the components do not jam in the tracks. All stepped bowls are cast aluminium, which need to be coated (see also page 18 Coating).



Type	TAG-Z 200-10-80	TAG-Z 200(324)-20-105	TAG-N 250-20-105	TAG-N 250-32-130	TAG-N 250-32-145	TAG-ZA 250-32-165
Capacity [l]*	0.5	1	1	2	2	2
Material	Aluminium	Aluminium	Aluminium	Aluminium	Aluminium	Aluminium
A = Discharge height	64	75	78	93	112	132
B = Width of track	10	20	20	32	32	32
C = Discharge radius	115	166	168	206	206	206
D = Bowl diameter	228	330	330	400	400	400
H = Bowl height	80	97	101	124	145	165
S = Track pitch	20	32	34	42	42+15**	42+15**
Bowl weight	0.8	2.6	1.65	2.9	3.4	6.9
Fixing	central	central	radial	radial	radial	central
Bottom (see page 13)	cast	cast	required	required	required	cast
Suitable drive unit	SRC-N 200	SRC-B 200	SRC-N 250	SRC-N 250	SRC-N 250	SRC-N 250
(see also page 14)						
Z = Total discharge height	252	263	323	338	357	377
Suitable base plate	SRG-N 200	SRG-N 200	SRG-N 250	SRG-N 250	SRG-N 250	SRG-N 250
(see also page 19)						

* Larger capacities available, dependent on application and components

** Additional gradient on last 180 degrees





Stepped Bowl

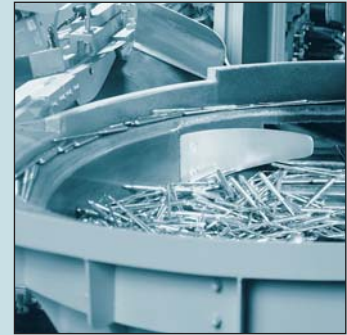
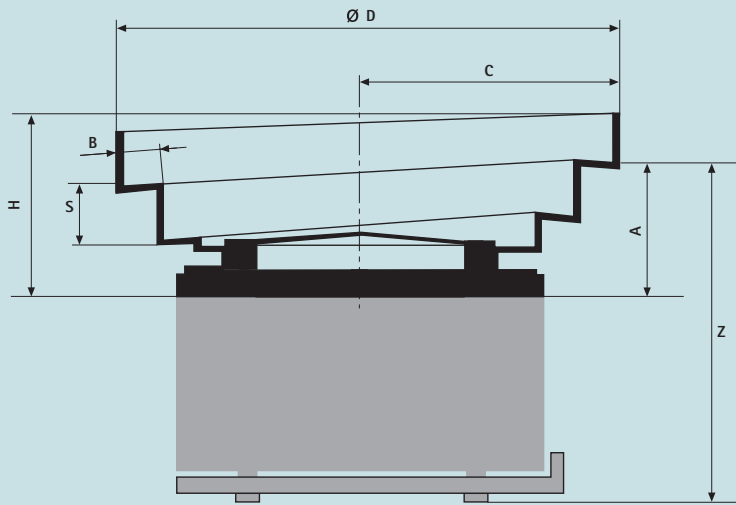

Please advise feed direction when ordering (see also page 5).

TAG-ZA 250(541)-32-180	TAG-N 400-32-165	TAG-N 400-50-190	TAG-N 400-50-215	TAG-ZA 400-50-240	TAG-N 630-50-220	TAG-N 630-65-230
7	7	10	10	10	25	25
Aluminium	Aluminium	Aluminium	Aluminium	Aluminium	Aluminium	Aluminium
140	120	135	161	187	157	157
32	32	50	50	50	50	65
275	275	335	335	335	440	440
545	545	645	645	650	830	830
180	175	190	215	240	220	230
50+15**	50+15**	68	68+23**	68+23**	76	95
8.2	5	9	11.7	14.7	18	18
central	radial	radial	radial	central	radial	radial
cast	required	required	required	cast	required	required
SRC-B 250	SRC-N 400	SRC-N 400	SRC-N 400	SRC-N 400	SRC-N 630	SRC-N 630
385	380	395	421	447	416	416
SRG-N 250	SRG-N 400	SRG-N 400	SRG-N 400	SRG-N 400	SRG-N 630	SRG-N 630

The measurements mentioned above are valid for standard equipment only without tooled devices. Subject to manufacturing tolerances.



Polyamide Bowls

Polyamide bowls have low friction and can be specially machined to customer's specifications and are easily reproduced. They also have a low noise level.

Stepped polyamide bowls (TKF) and conical polyamide bowls (KKF) are available.

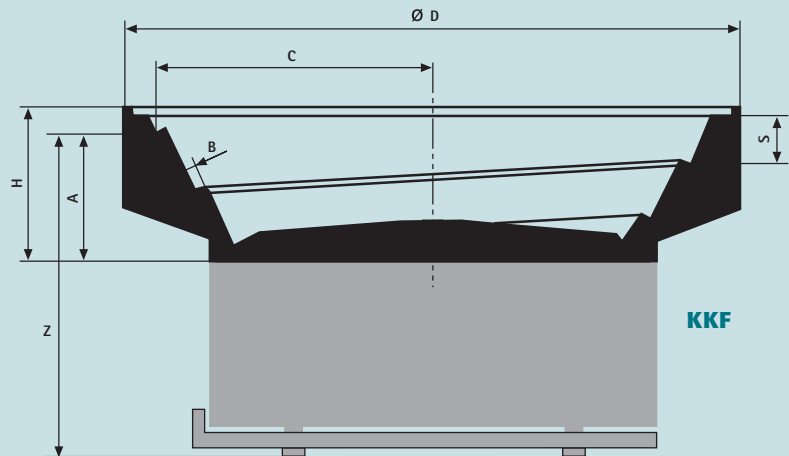

Please advise feed direction when ordering (see also page 5).

Type	KKF-Z 100-X-40	KKF-Z 200-X-60	KKF-ZA 250-X-120	TKF-Z 100-X-40	TKF-Z 200-X-60	TKF-ZA 250-X-120
Capacity [l]*	0.15	0.5	2.4	0.15	0.5	2.4
Material	PA 6-G	PA 6-G	PA 6-G	PA 6-G	PA 6-G	PA 6-G
A = Discharge height **	28-32	47-50	102-106	28-32	47-50	105-109
B = Width of track	2-10	2-10	2-10	2-10	2-10	2-10
C = Discharge radius **	38-45	97-100	175-185	38-45	96-105	175-185
D = Bowl diameter	120	220	400	120	220	400
H = Bowl height	40	60	120	40	60	120
S = Track pitch	12	20	28	12	20	36
Fixing	central	central	central	central	central	central
Suitable drive unit	SRC-N 100	SRC-N 200	SRC-N 250	SRC-N 100	SRC-N 200	SRC-N 250
(see also page 14)						
Z = Total discharge height	110-120	210-220	320-325	110-120	210-220	320-325
Suitable base plate	-	SRG-N 200	SRG-N 250	-	SRG-N 200	SRG-N 250
(see also page 19)						

* Larger capacities available, dependent on application and components

** Varied according to track width

Special sizes on request



The measurements mentioned above are valid for standard equipment only without tooling devices.
Subject to manufacturing tolerances.



Centres

If there is an aperture in the bottom of the bowl, either a rotating or fixed centre is required.

Material type:

PA = Polyamide

AL = Aluminium

VA = Stainless steel

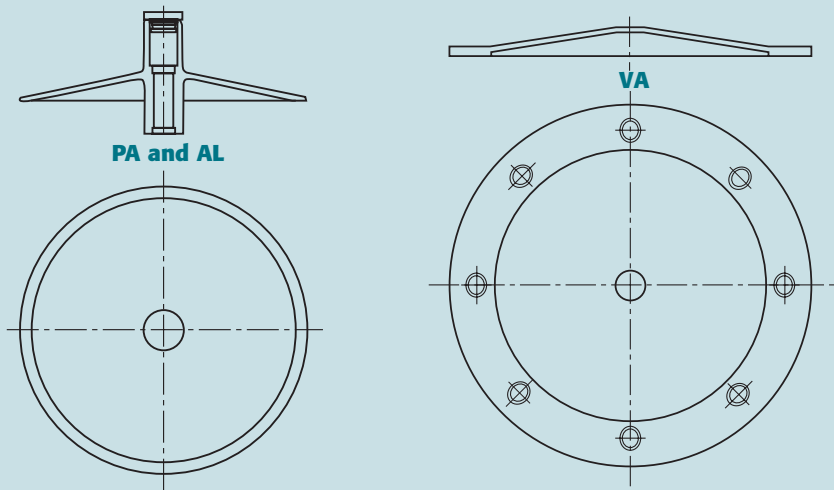

Rotating centres (SRL) are used in the following circumstances:

1. To relieve pressure on the bowl drive unit
2. Keeping vibration of components to a minimum
3. To reduce noise levels

Please note:

Certain products can get trapped between the rotating centre and base of the bowl and small quantities of parts may be left within the feeder. For heavy parts we recommend the use of an aluminium rotating centre (SRL AL).

Loose/rotating centres (non vibrating)

Size	SRL-N 250		SRL-N 400		SRL-N 630
Material	PA	AL	PA	AL	AL

Fixed centres (SRF) provide the following advantages:

1. There are no gaps to trap parts
2. The centre will not allow dust or debris into the drive unit
3. The bowl can be purged of components

Fixed centres (vibrating)

Size	SRF-N 250			SRF-N 400			SRF-N 630	
Material	PA	AL	VA	PA	AL	VA	AL	VA

Selection of basic material

Rotating Centre (stainless steel, only for fixed centres)

Suitable when a hopper feeds components into the same position on the centre at the bottom of the bowl. Will provide more durability.

Polyamide or aluminium centres (PA or AL)

The choice of the material is dependent upon the weight and condition of components.



Drive Units

RNA drive units offer reliability and endurance. The use of high performance magnets give a continuous high feed rate regardless of the number of parts in the bowl. RNA drive units are renowned for their durability, smooth feed characteristics and low noise levels.



SRC-N 63-2 SRC-N 100-2

Electrical Equipment

Supply Voltage 200V 50 Hz

Protection class IP54

Output vibrating frequency: -1=50 Hz/3000 min⁻¹
-2=100 Hz/6000 min⁻¹

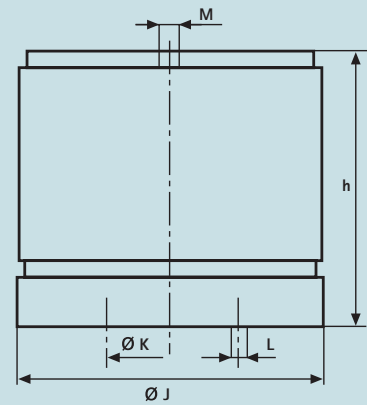

Application area for 50 Hz vibration frequency (-1 design)

- for heavy additional mass at the bowl (f.e. extensive orienting devices)
- for minor noise emission
- drive unit will be more damageable by heavy loading (filling weight) as by -2 design

Application area for 100 Hz vibration frequency (-2 design)

- if "fine" orienting devices are needed for small sort criterions of the work pieces
- better for critical cutting site passage (small vibrating cast of the work pieces)

Type	SRC-N 63-2	SRC-N 100-2	SRC-N 160-2	SRC-N 200-2	SRC-B 200-2**
h = Drive unit height/ Top casting	65	82	133	165	165
J = Drive unit diameter	60	90	157	180	180
K = Pitch between mountings/ no. of bores	40/2	70/3	120/3	130/3	130/3
L = Thread dimensions	M4	M4	M6	M6	M6
M = Bowl fixing	M5	M5	M8	M8	M8
N = Shoulder diameter	-	-	150	161	161
G = Bolt circle	-	-	-	-	-
Drive unit weight [kg]	0.8	1.8	7	11	11
Rating in amps [A]	0.04	0.055	0.55	1.2	1.2
Length of connection cable* [m]	1.4	1.4	1.4	1.4	1.4

Adapter plates for strange bowls see page 23-1

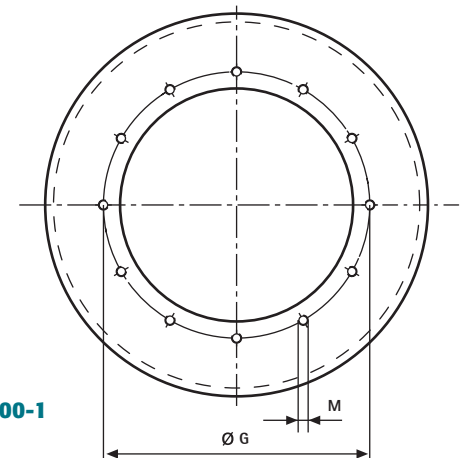
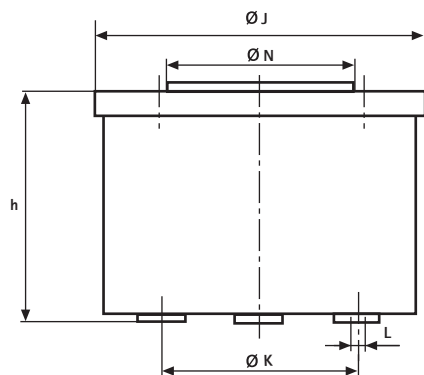

SRC-N 250-2 • SRC-B 250-2 • SRC-N 400-2 • SRC-N 400-1

SRHL 400-1 • SRHL 400-2 • SRC-N 630-1



Drive Units



SRC-N 160-2
 SRC-N 200-2
 SRC-B 200-2

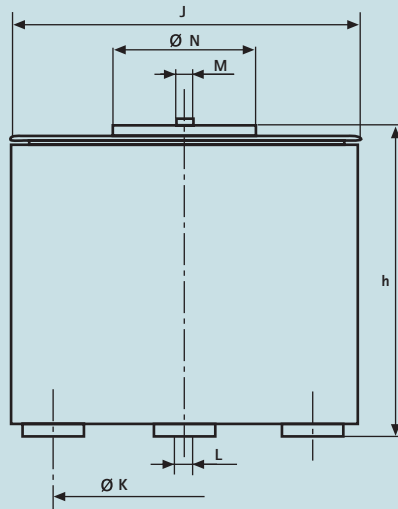

Standard nominal tension 200 V/50 Hz. Also available in special nominal tensions 110 V/220 V and frequencies 50 Hz/60 Hz.

SRHL The bowl feeder type SRHL 400 is a very efficient drive unit and is recommended for use with heavy tooling and high feed requirements.

SRC-N 250-2	SRC-B 250-2**	SRC-N 400-1	SRHL 400-1	SRC-N 630-1	SRC-N 800-1
215	215	228	255	225	315
290	290	440	470	660	826
220/3	220/3	350/3	350/3	560/3	735
M8	M8	M10	M10	M10	M10
M6 8 x 45°	M6 8 x 45°	M6 12 x 30°	M6 12 x 30°	M6 12 x 30°	-
165	165	300	300	500	-
186	186	320	320	525	-
40	40	103	140	168	270
2.6	2.6	3.75(...-1) 4.05(...-2)	5.7(...-1) 5.3(...-2)	5	8.5
0.5	0.5	0.5	0.5	0.5	1.4

* Longer connection cables are available upon request • ** Extra springs for larger capacity

Standard paint finish: RAL 6011 • Special paint finish on request

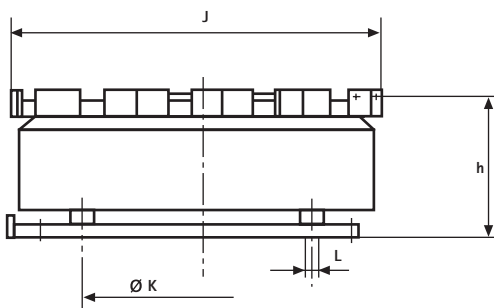

SRC-N 800-1

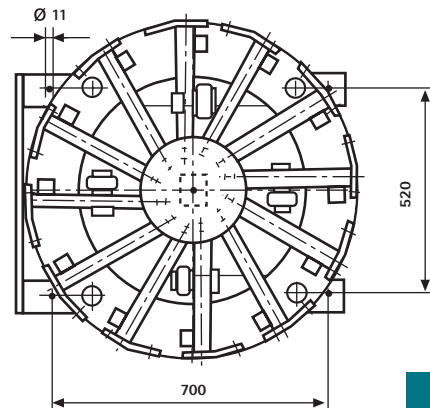

Please advise feed direction when ordering (see also page 5)



Control Boxes

RNA provides state of the art controllers for all vibratory drive units. These range from low cost units to self calibrating, high-tech controllers using microprocessor technology to control external sensors and provide communication signals. These are specially designed to meet the requirements of the bowl feeder industry. All controllers are CE approved.

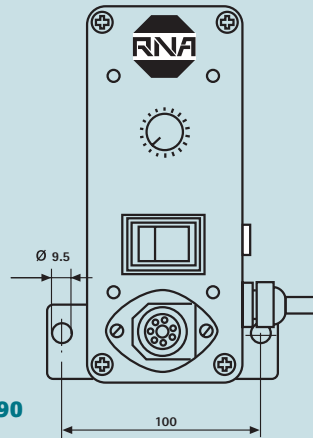

ESG 90

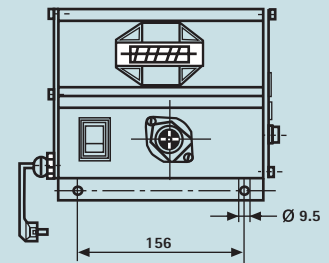
ESG-2000 • ESK-2000 • ESK-2001
ESR-2000

Boxes

Type	ESG 90	ESG-2000	ESK-2000	ESK-2001
Mains voltage	230 V AC, 50/60 Hz, +20/-15% 110 V AC, 50/60 Hz, +10/-10%	230 V AC, 50/60 Hz, +20/-15% 110 V AC, 50/60 Hz, +10/-10%	230 V AC, 50/60 Hz, +20/-15% 110 V AC, 50/60 Hz, +10/-10%	230 V AC, 50/60 Hz, +20/-15% 110 V AC, 50/60 Hz, +10/-10%
Output voltage	0 ... 208 V _{eff} / 230 V AC 20 ... 105 V _{eff} / 110 V AC	0 ... 208 V _{eff} / 230 V AC, 0 ... 98 V _{eff} / 110 V AC	0 ... 208 V _{eff} / 230 V AC, 0 ... 98 V _{eff} / 110 V AC	0 ... 208 V _{eff} / 230 V AC, 0 ... 98 V _{eff} / 110 V AC
Control method	Phase angle control	Phase angle control	Phase angle control	Phase angle control
Load current max. channel 1+2	–	–	–	10 A _{eff} / 4 A _{eff}
Load current max.	6 A _{eff}	10 A _{eff}	10 A _{eff}	10 A _{eff}
Load current min.	80 mA	80 mA	80 mA	80 mA
Internal fuse	microfuse 5x20, 6,3 A slow	F 1 = 10 A	F 1 = 10 A	F 1 = 10 A / F 2 = 4 A
Soft start/stop time	Soft start only	0 ... 5 sec. independently adjustable	0 ... 5 sec. independently adjustable	0 ... 5 sec. independently adjustable
External speed control	–	–	0 ... 10 V DC	0 ... 10 V DC
Sensor inputs	–	–	2	2
Remote control input	contact or 24 V DC	24 V DC (10-24 V DC)	24 V DC (10-24 V DC)	24 V DC (10-24 V DC)
Sensor power supply	–	–	24 V DC, max. 60 mA (per sensor)	24 V DC, max. 60 mA (per sensor)
Sensor delay On	–	–	0 ... 60 sec.	0 ... 60 sec.
Sensor delay Off	–	–	0 ... 60 sec.	0 ... 60 sec.
Outputs	–	2 Optocouplers	2 Relay / 2 Optocouplers	2 Relay / 2 Optocouplers
Status output (optocouplers)	–	max. 30 V DC 10 mA	max. 30 V DC 10 mA	max. 30 V DC 10 mA
Relay output contacts	–	–	max. 6 A 250 V AC	max. 6 A 250 V AC
Operating temperature	0 ... 50 °C	0 ... 50 °C	0 ... 50 °C	0 ... 50 °C
Protection class	IP 54	IP 54	IP 54	IP 54
Dimensions W x H x D	80 x 190 x 140	192 x 180 x 132	192 x 180 x 132	192 x 180 x 132



Control Boxes

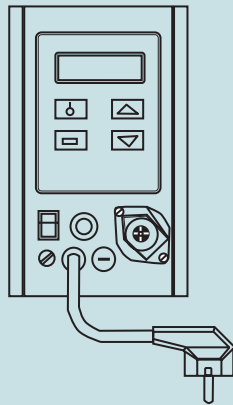

ESR 25/5A • ESR 28/8A

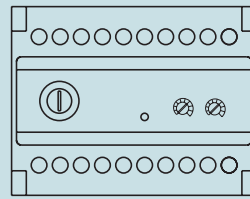

ESM 906

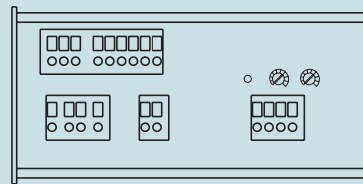

ESM 910



Plug-in types

Modular for integration in switch cabinets

ESR 2000	ESR 25/5A*	ESR 28/8A	XSG 90	ESM 906	ESM 910
230 V AC, 50/60 Hz, convertible to 110 V AC 50/60 Hz	230 V AC 50/60 Hz convertible to 110 V AC 50/60 Hz	230 V AC 50/60 Hz convertible to 110 V AC 50/60 Hz	230 V +- 10%, 50/60 Hz	230 V AC, 50/60 Hz +6% / -10% 110 V AC, 50/60 Hz +6% / -10%	230 V AC, 50/60 Hz +6% / -10% 110 V AC, 50/60 Hz +6% / -10%
0 ... 208 V _{eff} / 230 V AC 20 ... 105 V _{eff} / 110 V AC	0 ... 210 V _{eff} / 230 V AC 20 ... 105 V _{eff} / 110 V AC	0 ... 210 V _{eff} / 230 V AC 20 ... 105 V _{eff} / 110 V AC	30 ... 204 V AC	0 ... 220 V _{eff} / 230 V AC 0 ... 105 V _{eff} / 110 V AC	0 ... 220 V _{eff} / 230 V AC 0 ... 105 V _{eff} / 110 V AC
Variable frequency PWM	Variable frequency PWM	Variable frequency PWM	Phase angle control	Phase angle control	Phase angle control
-	-	-	-	-	-
6 A _{eff}	5.5 A _{eff}	8.5 A _{eff}	10 A _{eff}	6 A _{eff}	10 A _{eff}
80 mA	60 mA	60 mA	80 mA	-	-
F 1 = 10 A	mains fuse: 5x20 mm, 4 A slow, 12 13 72		5 x 20, 10 A	-	-
0 ... 5 sec. independently adjustable	Input: 0,05 - 10 sec. / Output:	0,005 - 10 sec.	0,05 - 10 sec.	Fixed pre-set soft start	
0 ... 10 V DC	-	-	-	0 ... 10 V or Poti 10 / k Ω	
2	1	1	-	-	-
24 V DC (10-24 V DC)	extend. with add. print	-	Optocouplers 10 ... 24 V DC	Potential free contact / 12 ... 24 V DC, Ri 10 k Ω	
each 24 V DEC, max. 60 mA	each 24 V DEC, max. 60 mA	each 24 V DEC, max. 60 mA	-	0 - 20 mA / 0 ... 10 V or Poti 10 / k Ω	
0 ... 60 sec.	Sensor signal delays: 0.000 bis 10 sec.		-	-	-
0 ... 60 sec.	Sensor signal delays : 0.000 bis 10 sec.		-	-	-
as max. 6 A 250V AC, 2 optocouplers max. 30 V DC	-	-	-	2/0 PTO couplers	-
max. 30 V DC 10 mA	24 V, 50 mA	24 V, 50 mA	Status outputs 30 V 0,1 A	30 V 0.1 A DC	30 V 0.1 A DC
max. 6 A 250 V AC	-	-	-	-	-
0 ... 50 °C	0 ... 40 °C	0 ... 40 °C	0 ... 50 °C	0 ... 45 °C	0 ... 45 °C
IP 54	IP 54	IP 54	IP 20	IP 20	IP 20
192 x 180 x 132	140 x 220 x 160	140 x 220 x 160	Plug in eurocard type 8 TE	104 x 177 x 112	150 x 74 x 109

* Also available with reduced output current 0,6 A and 1,8 A, suitable for small drive units.



Coating

Coating minimises wear and tear, reduces noise and damage to components. Coatings can be selected according to the application.



Coating material	Characteristics	Application
Polyurethane spray coating colour: beige	- smooth surface	rubber and plastic parts
Polyurethane lining, 1 mm thickness colour: black	- high durability, good sound reduction and can be applied either side i.e. smooth or rough side can be used as track surface. Rough surface is suitable for wet parts	dry and clean metal parts and heavy plastic parts
Polyurethane lining, 2 mm thickness colour: black	as above plus: - very hard wearing, - abrasion resistant, - shock proof and very good sound suppression	as above plus: heavy sharp metal, glass and abrasive parts e.g. screws, forged and pressed parts
Polyurethane lining ribbed, colour: black	- allows oil dispersal through ribs	oily, wet and sticky parts (pressings and stampings)
Habasit lining (HAM-5P), colour: green suitable for food, colour: white	- high feed rates for wet/oily parts - reduces static on plastic parts side wall coated with polyurethane foil (1 mm)	Parts with smooth surfaces, light plastic parts and light oily parts (pull-in oil, separating agent)
Brush coating	- feeding of oily parts, gentle/careful feeding, noise reduction	blank screws, heavy metal parts, parts with delicate surfaces
Flock lining, textile surface	- gentle parts feeding - improved feed rates	light parts with delicate surfaces prone to marking





Base Plates

Base plates enable easy mounting of the drive unit to the machine bed. Fixing locations are provided for RNA control boxes. When using a top plate type UP, UL and UK, base plates are necessary (see page 21, Stands and Top Plates).

SRG-N 160
SRG-N 200

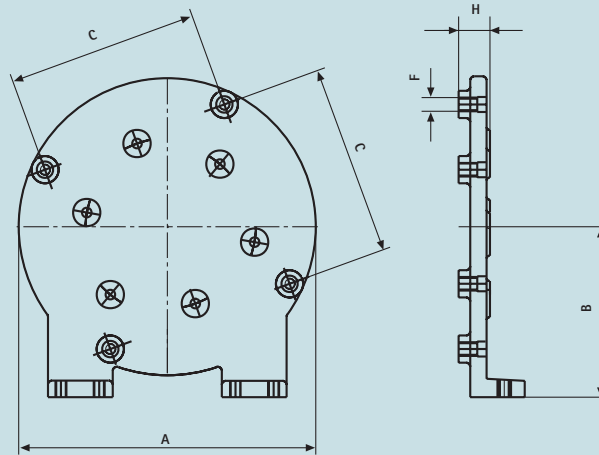

Type	SRG-N 160	SRG-N 200	SRG-N 250	SRG-N 400	SRG-N 630
A = Plate diameter	218	218	332	485	720
B = Position of control box mounting	125	125	172	253	375
C = Fixing hole centres	140	140	220	325	488
F = Thread size	M8/Km6	M8/Km6	M10/Km8	M10	M10
H = Plate height	23	23	30	32	34

Base plates are aluminium and black powder coated

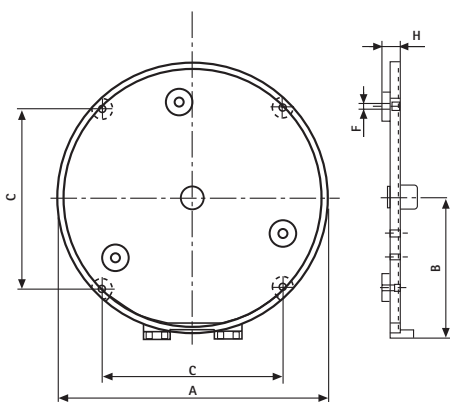

SRG-N 250
SRG-N 400

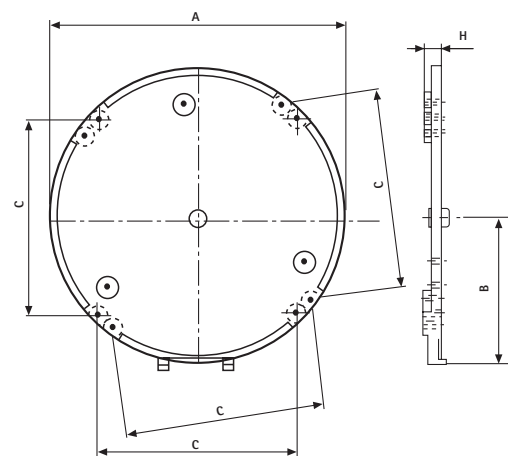

SRG-N 630



Sensors

Thru-beam sensors are used for minimum/maximum level control on a linear track.

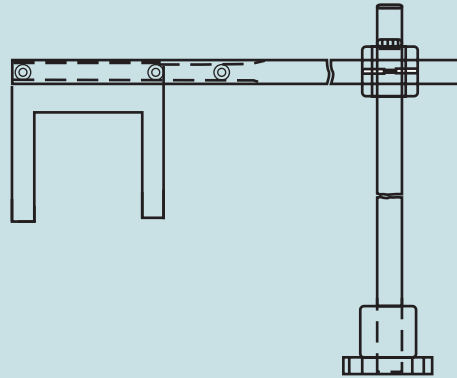

Type	EGF 50 untimed	EGF 80 timed	EGF 120 timed
Sensor width	50	80	120
Supply voltage	10 ... 30 V	10 ... 35 V DC	10 ... 35 V DC
Output	pnp	pnp/npn	pnp/npn
Load current	200 mA, short circuit proof	200 mA, short circuit proof	200 mA, short circuit proof
Internal power consumption	< 35 mA	< 30 mA	< 45 mA
Voltage drop	< 2.8 V	< 2.8 V	< 2.0 V
Operating frequency	10 kHz	4 kHz	1 kHz
Resolution, smallest detectable part	average 1.5 mm	average 0.5 mm	average 2.0 mm
Switch hysteresis	< 0.3 mm	< 0.25 mm	< 0.2 mm
Repeatability	0.02 mm	0.06 mm	0.08 mm
Ambient temperature	-10 ... + 60 °C	-10 ... + 60 °C	-10 ... + 60 °C
Insensitivity to parasitic light	1 kLux	80 kLux	10 kLux
Insulation voltage endurance	500 V	500 V	500 V
Protection class	IP 67	IP 67	IP 67
Housing material	Aluminium black anodised	Zinc black chromised	Zinc black chromised

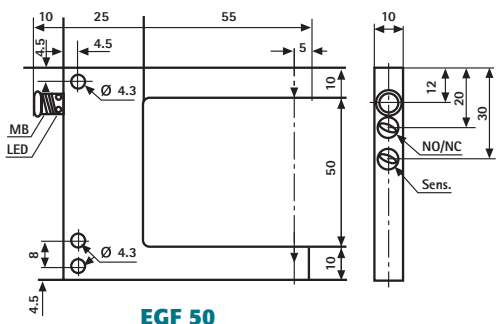

EGF 50

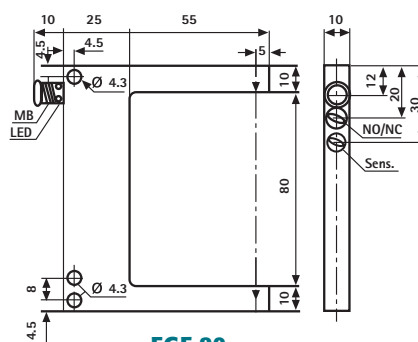

EGF 80

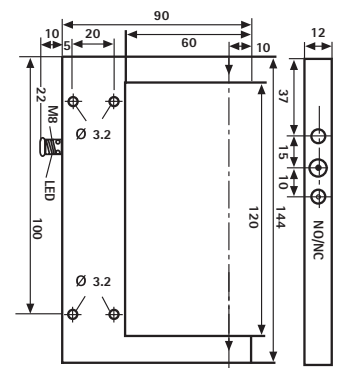

EGF 120



Feeder Stand and Top Plates

RNA feeder stands and top plates provide a wide range of adjustment to allow precise alignment in 3 axes. Top plates are pre-drilled to accept the relevant RNA drive units.

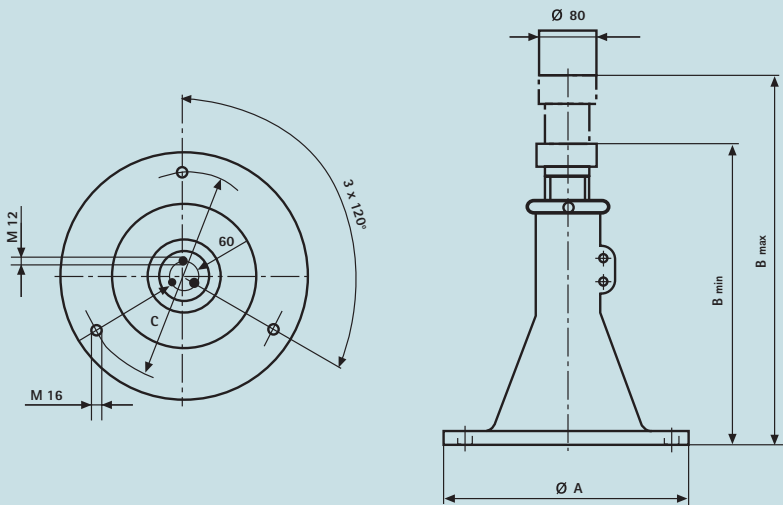

Feeder stands consist of a cast iron pedestal, painted RAL 6011 and fitted with an adjustable threaded column.

Type	UG 400-535	UG 400-735	UG 400-935	UG 630-535	UG 630-735	UG 630-935
A	400	400	400	630	630	630
B minimum	535	735	935	535	735	935
B maximum	790	990	1190	790	990	1190
C	340	340	340	560	560	560

Top plate type UP

Type	UP-120*	UP-250	UP-400	UP-630
A	120	250	380	550
B	20	21	21	21
C	100	220	325	488

* For use with special baseplates

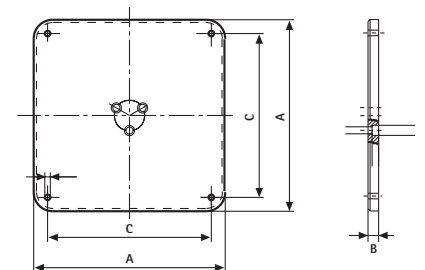

Top plate type UL, adjustable only in one direction

Type	UL-250	UL-400	UL-630
A	250	380	550
B	44	44	44
C	220	325	488
Total traverse path X	54	83.5	82

Top plate – type UK, adjustable in both directions

Type	UK-250	UK-400	UK-630
A	250	380	550
B	64	64	64
C	220	325	488
Total traverse path X	83.5	83	83.5
Total traverse path Y	70	83	82

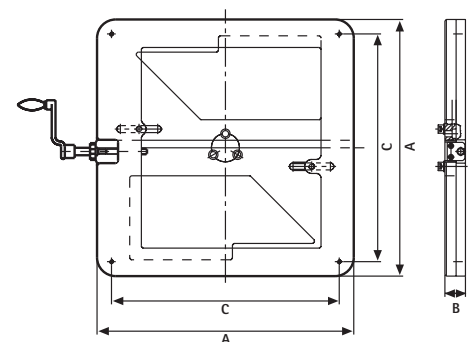

Sound Cover

Reduces noise and protects against dust and contamination.

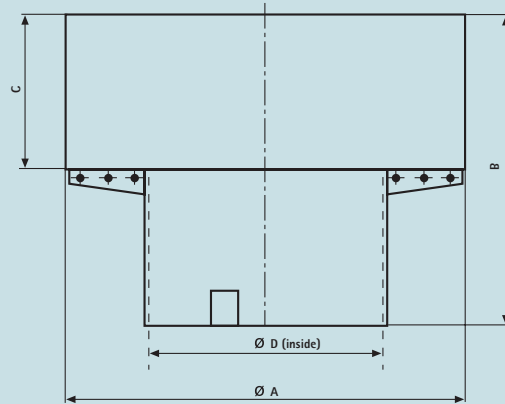













Type	HK-S 250	HK-S 400	HK-S 630
A* = Total diameter	550	880	1100
B* = Total body height	435	525	565
C* = Upper body height	230	310	350
D = Inner diameter	333	488	723

* Measurements of A, B, C are variable

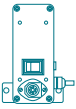
Sound Cover Type HK-S

- Suitable for bowl feeder from SRC-N 250 to SRC-N 630 with base plate type SRG
- Stainless steel with acoustic material
- RAL 6011 (outside), structure painted green, special paints available on request
- Lid made from polycarbonate for sizes 400 and above, a hinged lid is available as an option



Equipment		63	100	160	200
	Drive units	SRC-N 63-2	SRC-N 100-2	SRC-N 160-2	SRC-N 200-2 SRC-B 200-2
	Cylindrical bowls	ZAD-Z 63-4-18	ZAD-Z 100-6-50	ZSD-Z 160-12-70 ZSB-Z 160-12-70	ZSB-Z 200-12-80
	Conical bowls	KAD-Z 63-4-30	KAD-Z 100-4-40		KSB-Z 200-18-55 KSB-ZA 200-5RG-150
	Stepped bowls				TAG-Z 200-10-80 TAG-Z 200(324)-20-105
	Synthetic bowls	on request	KKF-Z-X-40 TKF-Z 100-X-40	on request	KKF-Z 200-X-60 TKF-X-200-X-60
	Adapter plates				
	Fixed bowl centre				
	Rotating bowl centre				
	Control box compatability	ESG 90 ESG 2000 ESK 2000 ESG 2001 ESK 2001	ESG 90 ESG 2000 ESK 2000 ESG 2001 ESK 2001	ESG 90 ESG 2000 ESK 2000 ESG 2001 ESK 2001	ESG 90 ESG 2000 ESK 2000 ESG 2001 ESK 2001
	Control box compatability frequency controller	ESR 2000 ESR 25	ESR 2000 ESR 25	ESR 2000 ESR 25	ESR 2000 ESR 25
	Control box (din rail mounted type)	ESM 906	ESM 906	ESM 906	ESM 906
	Control box (card type)	XSG 90	XSG 90	XSG 90	XSG 90
	Baseplate			SRG 160	SRG 200
	Sound cover				
	Feeder stand together with threaded column				
	Top plate for feeder stand				
	X movement slide for feeder stand				
	X/Y movement slide for feeder stand				



250	400	630	800
SRC-N 250-2 SRC-B 250-2	SRC-N 400-2 SRHL 400-1 SRC-N 400-1 SRHL 400-2	SRC-N 630-1	SRC-N 800-1
ZSB-N 250-30-110 ZSB-ZA 250-30-125	ZSB-N 400-30-160 ZSB-BA 400-30-175 ZSB-Z2A 400-30-190	ZSB-N 630-50-180 ZSB-BA 630-50-195	ZSB-B 800-80-220
KSB-N 250-20-90 KSB-ZA 250-20-105 KSB-ZA 250-20-150 KSB-ZA 250-8RG-150	KSB-N 400-50-160 KSB-BA 400-50-175 KSB-BA 400-15RG-220 KSB-Z2A 400-50-190 KSB-Z2A 400-15RG-235	KSB-N 630-50-180 KSB-BA 630-50-190 KSB-BA 630-15RG-250	KSB-N 800-80-170
TAG-N 250-20-105 TAG-N 250-32-130 TAG-N 250-32-145 TAG-ZA 250-32-165 TAG-ZA 250(541)-32-180	TAG-N 400-32-175 TAG-N 400-50-190 TAG-N 400-50-215 TAG-ZA 400-50-240	TAG-N 630-50-220 TAG-N 630-65-230	
KKF-ZA 250-X-120 TKF-ZA 250-X-120	on request		
AAG-Z 250	AAG-R 400 AAG-Z 400 AAG-Z 400(Z)	AAG-R 630	
SRF-N 250(PA) SRF-N 250(AL) SRF-N 250(VA)	SRF-N 400(PA) SRF-N 400(AL) SRF-N 400(VA)	SRF-N 630(AL) SRF-N 630(VA)	
SRL-N 250(PA) SRL-N 250(AL)	SRL-N 400(PA) SRL-N 400(AL)	SRL-N 630(AL)	
ESG 90 ESG 2000 ESK 2000 ESG 2001 ESK 2001	ESG 90 ESG 2000 ESK 2000 ESG 2001 ESK 2001	ESG 90 ESG 2000 ESK 2000 ESG 2001 ESK 2001	ESG 2000 ESK 2000 ESG 2001 ESK 2001
ESR 2000 ESR 25	ESR 2000 ESR 25	ESR 2000 ESR 25/28	ESR 28
ESM 906 XSG 90	ESM 906 XSG 90	ESM 910 XSG 90	ESM 910 XSG 90
SRG 250 HK-S 250	SRG 400 HK-S 400	SRG 630 HK-S 630	
UG 400-535 UG 400-935	UG 630-535 UG 400-735 UG 630-935	UG 630-535 UG 630-735 UG 630-935	UG 630-735
UP 250 UL 250 UK 250	UP 400 UL 400 UK 400	UP 630 UL 630 UK 630	

Overview of RNA Equipment – Bowl Feeders



RNA-Code for Bowls

K S B - Z A - 250 - 8 (R G) - 150

Bowl type
Z = cylindrical
K = conical
T = stepped

Material
A = Aluminium
S = Stainless steel
K = Polyamide

Manufacture
B = sheet metal
D = turned
F = machined
G = cast

Centres-/different fixings
N = ("NIL") additional centres required
Z = welded bottom with centre fixing
B = welded bottom only
A = inc. adapter plate
2A = additional adapter plate for centre fixing

Drive unit
X = variable

Track width (mm)
X = variable

Track type
R = rectangular
G = closed

Bowl height (mm) from the screwing on point



Enquiry form

Fax to:
RNA Automation LTD

Fax No. ++44 (121) 749 6217

or post it to:
RNA Automation LTD
Hayward Industrial Park Tameside Drive
Castle Bromwich, Birmingham, B35 7AG

Or fax to:

RNA Automated Systems Inc.

Fax No. ++1 (509) 304 9951

or post it to:
RNA Automated Systems Inc.
1349 Sandhill Drive Unit 101
Ancaster, Ontario
Canada, L9G 4V5

Sender:

Company

Contact name

Street

Postcode, City, Country

Telephone

Fax

E-Mail

Internet

Your enquiry:

Component

Dimension

Weight

Material

Speed (component/min)

Capacity

Further information

Drawing/Sketch



Rhein-Nadel Automation GmbH

Reichsweg 19-42
D-52068 Aachen
Tel.: ++49 (241) 5109-0
Tel. Vertrieb:
++49 (241) 5109-159
Fax: ++49 (241) 5109-219
E-Mail: vertrieb@rna.de
www.rna.de

HSH Handling Systems AG

Wangenstr. 96
CH-3360 Herzogenbuchsee
Tel.: ++41 (62) 956 10-00
Fax: ++41 (62) 956 10-10
E-Mail: info@handling-systems.ch
www.rna.de

RNA Automation LTD

Hayward Industrial Park
Tameside Drive,
Castle Bromwich
Birmingham, B35 /AG
Tel.: ++44 (121) 749-2566
Fax: ++44 (121) 749-6217
E-Mail: rna@rna-uk.com
www.rna-uk.com

Vibrant. S.A.

Pol. Ind. Famades c/Energia,
Parc 27,
E-08940 Cornellà de Llobregat
(Barcelona)
Tel.: ++34 (93) 377-7300
Fax: ++34 (93) 377-6752
E-Mail: info@vibrant-rna.com
www.vibrant-rna.com

RNA Automated Systems Inc.

1349 Sandhill Drive Unit 101
Ancaster, Ontario, Canada L9G 4V5
Tel.: +1 (905) 304-9950
Fax: +1 (905) 304-9951
E-Mail: sales@rna-can.com
www.rna-can.com

Update: April 2005

DW 2949

