

Packaging Industry

# SPEEDPACKER

## SPEEDFORMER KMD Series



The SPEEDPACKER is a standard automation module for the SPEEDFORMER **KMD** Series.

Benefit from buffer time and ergonomic packing height for multiple machine operation by one person.

Increase your production efficiency.

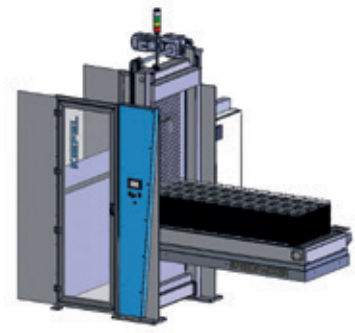
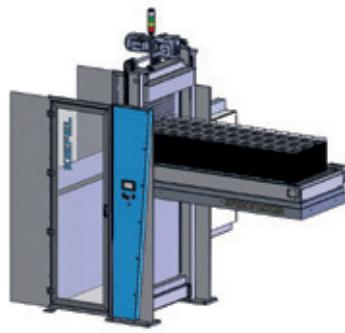
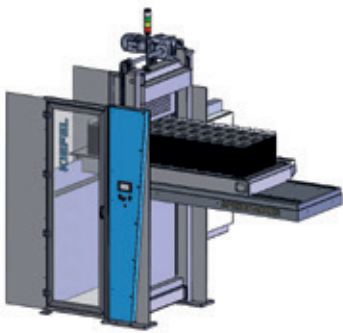

**Automated shuttle transfer**

- Flexible for new and existing steel rule thermoforming machines

**More effective packing**

- Product buffering for maximum efficiency

**Ergonomic packing height**

- Easy product removal

Standard automation  
for **KMD** series  
**SPEEDPACKER**

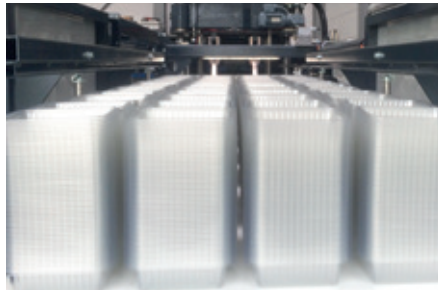

Build up product stacks – maximize buffer time

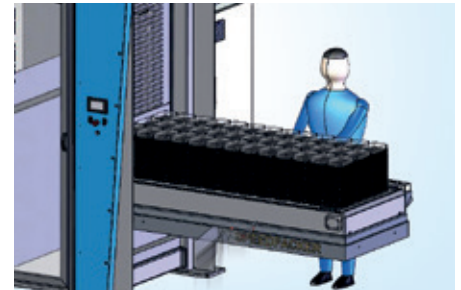

Same packing point

**Turnkey Solution**

- For existing KMDs: Easy integration/upgrade of SPEEDPACKER
- New KMDs: Already includes enhanced interface for SPEEDPACKER

**Highlights**

- Reduce labour- and associated costs
- Ergonomic packing height at same packing point
- Safer work environment (no platforms)
- Flexible for existing and new steel rule thermoforming machines – from other brands too

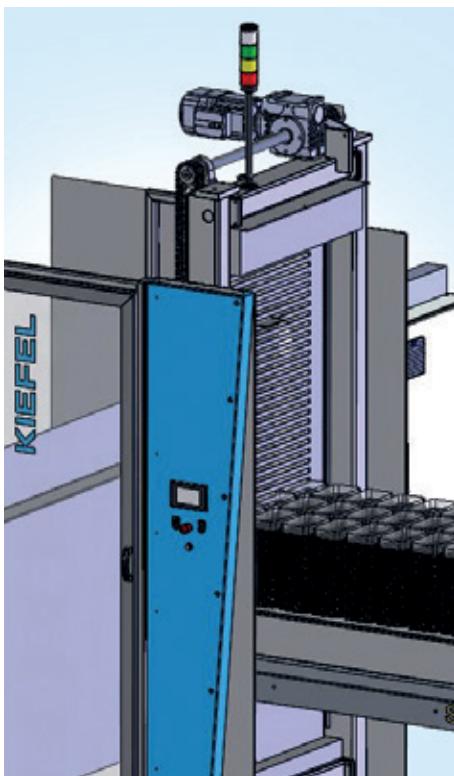

Easy to operate

Technical data	SPEEDPACKER
Product reception/ packing height	700 – 1,000 mm
Buffer dimension	approx. 2,000 x 780 mm
Conveyor belt speed	adjustable
Overall dimensions	approx. 3,500 x 1,900 x 3,000 mm