



Serie  
**CS**



TREVI BENNE S.p.A.  
Via A. Volta, 5  
36025 Noventa Vic.na  
Vicenza (VI) - Italy  
Tel. +39 0444 760773  
Fax +39 0444 861182  
[www.trevibenne.it](http://www.trevibenne.it)  
[info@trevibenne.it](mailto:info@trevibenne.it)

# Serie **MARILYN**

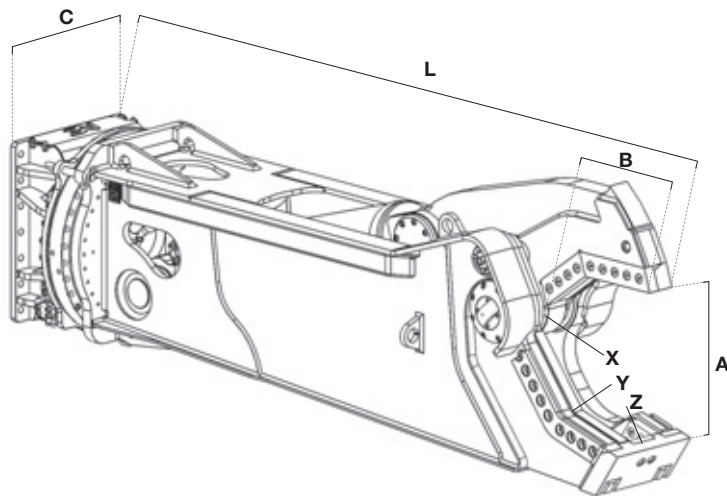

		CS 05R	CS 07R	CS 20RS	CS 30RS	CS 40RS	CS 55RS	CS 70RS	CS 90RS
(1)	t.	2,5 : 4	4 : 7	10 : 16	17 : 22	25 : 30	30 : 40	45 : 55	70 : 90
(2)	t.	5 : 8	8 : 12	18 : 25	30 : 38	40 : 50	55 : 70	75 : 100	120 : 150
*	kg.	450	750	1650	2800	3900	5650	7180	9250
A	mm.	340	405	535	615	680	780	845	920
B	mm.	320	355	445	545	600	690	710	780
C	mm.	460	460	715	715	865	1000	1100	1200
L	mm.	1725	2050	2660	3110	3420	3905	4190	4400
	t.	35	50	70	125	145	160	205	285
X	t.	125	210	270	550	600	715	875	1190
Y	t.	50	90	125	230	270	290	375	535
Z	t.	25	50	70	125	145	160	205	295
	bar	250	310	310	340	340	340	340	340
	l/min.	80 / 150	100 / 150	180 / 250	200 / 300	300 / 400	400 / 500	450 / 600	500 / 800
MAX	bar	120	120	140	140	140	140	140	140
MAX	l/min.	10	10	10	10	10	30	30	50
Drenaggio / Tank		/	/	/	/	/	1/4" gas	1/4" gas	1/4" gas
		3/4" gas	3/4" gas	1" gas	1" gas	1" gas	1" 1/4 gas	1" 1/4 gas	1" 1/2 gas
		3/8" gas	3/8" gas	3/8" gas	3/8" gas	3/8" gas	1/2" gas	1/2" gas	1/2" gas

(\*) I PESI SOPRA DESCRITTI NON INCLUDONO LA SELLA ATTACCO. CARATTERISTICHE DI PRODOTTO E SPECIFICHE POSSONO VARIARE SENZA OBBLIGO DI PREAVVISO.

(\*) THE ABOVE MENTIONED WEIGHTS DO NOT INCLUDE THE EXCAVATOR ATTACHMENT. SPECIFICATIONS ARE SUBJECT TO CHANGE WITHOUT NOTICE.

(\*) LOS PESOS INDICADOS NO COMPRENDEN EL ENGANCHE EXCAVADORA. LAS CARACTERÍSTICAS DEL PRODUCTO Y LAS ESPECIFICACIONES PUEDEN VARIAR SIN OBLIGACIÓN DE PREAVISO.

(\*) LES POIDS INDICÉS NE COMPRENNENT PASS L'ATTACHE POUR LA PELLE. LES CARACTÉRISTIQUES ET LES SPÉCIFICATIONS DES PRODUITS PEUVENT ÊTRE MODIFIÉES SANS PRÉVIS.

(1) MONTAGGIO CESOIA AL POSTO BRACCIO. EXCAVATOR WEIGHT BOOM MOUNTED. MONTAJE CIZALLA EN EL BRAZO DE LA EXCAVADORA. POIDS DE LA PELLE MONTAGE PLACE DU BRAS.

(2) MONTAGGIO CESOIA AL POSTO BENNA. EXCAVATOR WEIGHT STICK MOUNTED. MONTAJE CIZALLA EN EL BALANCIN DE LA EXCAVADORA. POIDS DE LA PELLE MONTAGE PLACE DE LA GODET.