

Adaptadores de Ripper

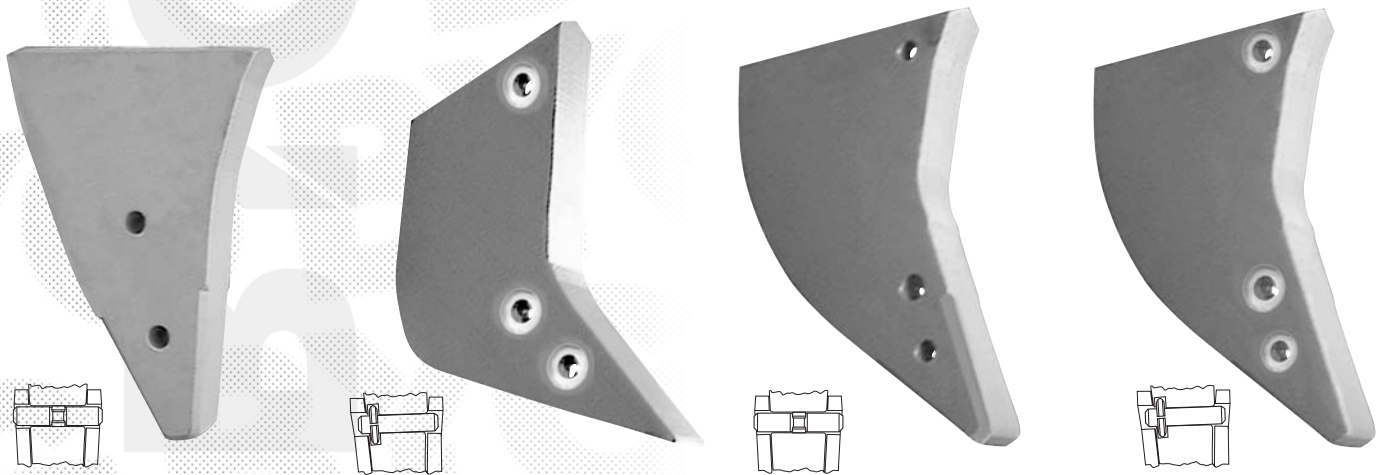

Montaje con arandela central

Montaje con pasador y arandela

Montaje con arandela central

Montaje con pasador y arandela

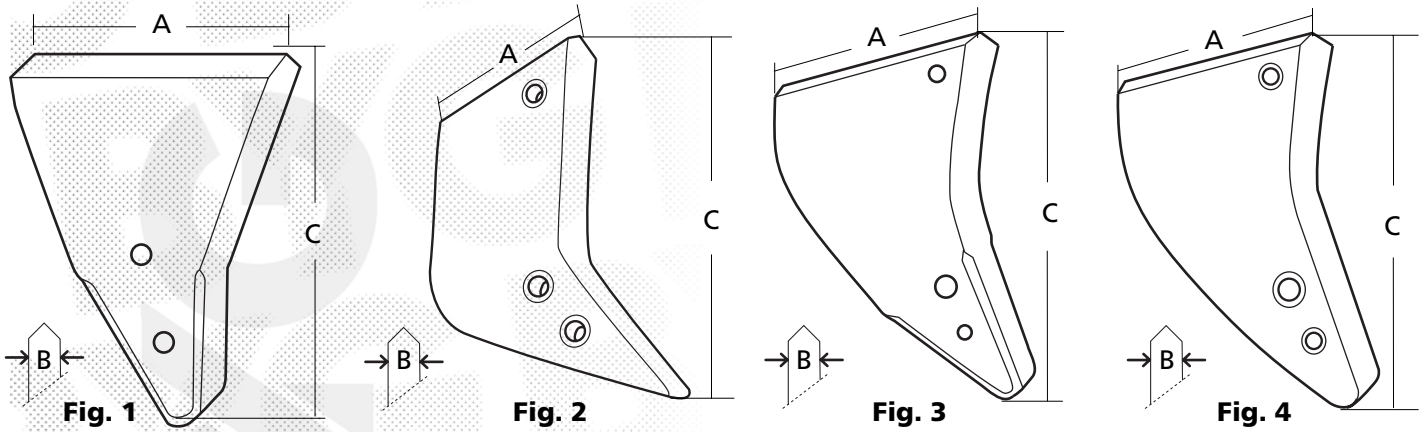

	mm.			Fig 1	Fig 2	Fig 3	Fig 4									
	A	B	C													
D4, 941, 951, 955, 963, 12, 14, 130, 140, 143H, 160H	-	-	-	-	-	-	-	-	-	-	-	4T-4302 9W-7309 6Y-0309	-	-	⇒	
16, 973, 977, D5, D6, D7, 983	-	-	-	-	-	-	-	-	-	-	-	4T-4352 6Y-0359	-	-	⇒	
D7, D8, D9	240 9,45"	75 2,95"	500 19,69"	-	7J-2588	-	-	7J-9600	-	6J-8811	-	7J-3309 7J-3310 7J-3312	6J-8811	-	7J-2514 7J-2515 7J-2459	⇒
D8K, D8L, D8N, D9H, D9N	360 14,17"	75 2,95"	600 23,62"	-	-	7J-1791	-	7J-9600	-	6J-8811	-	9W-2451 9W-2452 9W-2452 ST 8E-5570 114-0453 4T-5451 4T-5452 8E-5571	7J-9600	-	7J-1792 8E-5341 7J-1793 4T-8989 7J-1795 4T-0134 107-3485 4T-8990 107-3486 8E-5347 8E-5346 8E-5340 4T-0135 7J-1794 4T-0134 8E-5345 4T-0136 9W-6167 8E-5342 4T-8988 8E-5340 4T-8990	⇒
D9L, D10, D10N, D11, D11N	430 16,93"	90 3,54"	600 23,62"	1U-3630	-	-	-	-	-	3G-0500	-	4T-4501 4T-4502 4T-4502 ST 4T-4503 4T-5501 4T-5502 8E-5572 4T-5503	3G-0500	-	3G-2088 3G-6507 9W-4427 1V-4592 9J-5954 1U-4873 6Y-6138 6Y-5616 6Y-6144 8E-8412 6Y-6141 8E-8413 8E-8414 9W-8366 8E-8416 6Y-6147 8E-8415 8E-8411 6Y-4679 8E-8417	⇒
D11, D11N	500 19,69"	110 4,33"	800 31,50"	-	-	103-8115	-	6Y-3909 4T-4707	-	6Y-3909 4T-4707	-	9W-4551 9W-4552 6Y-3552	-	6Y-3909 4T-4707	7T-6020 9W-0259 8E-0467 8E-1466	⇒
	800 31,50"	-	-	-	6Y-9473 6Y-9473 EXT	-	9W-1821	-	9W-1821	-	-	9W-1821	-	-	-	
	1200 47,24"	-	-	-	104-9279 104-9279 EXT	-	8E-2229 8E-2230	-	8E-2229 8E-2230	-	-	8E-2229 8E-2230	-	-	-	

Narices de Ripper

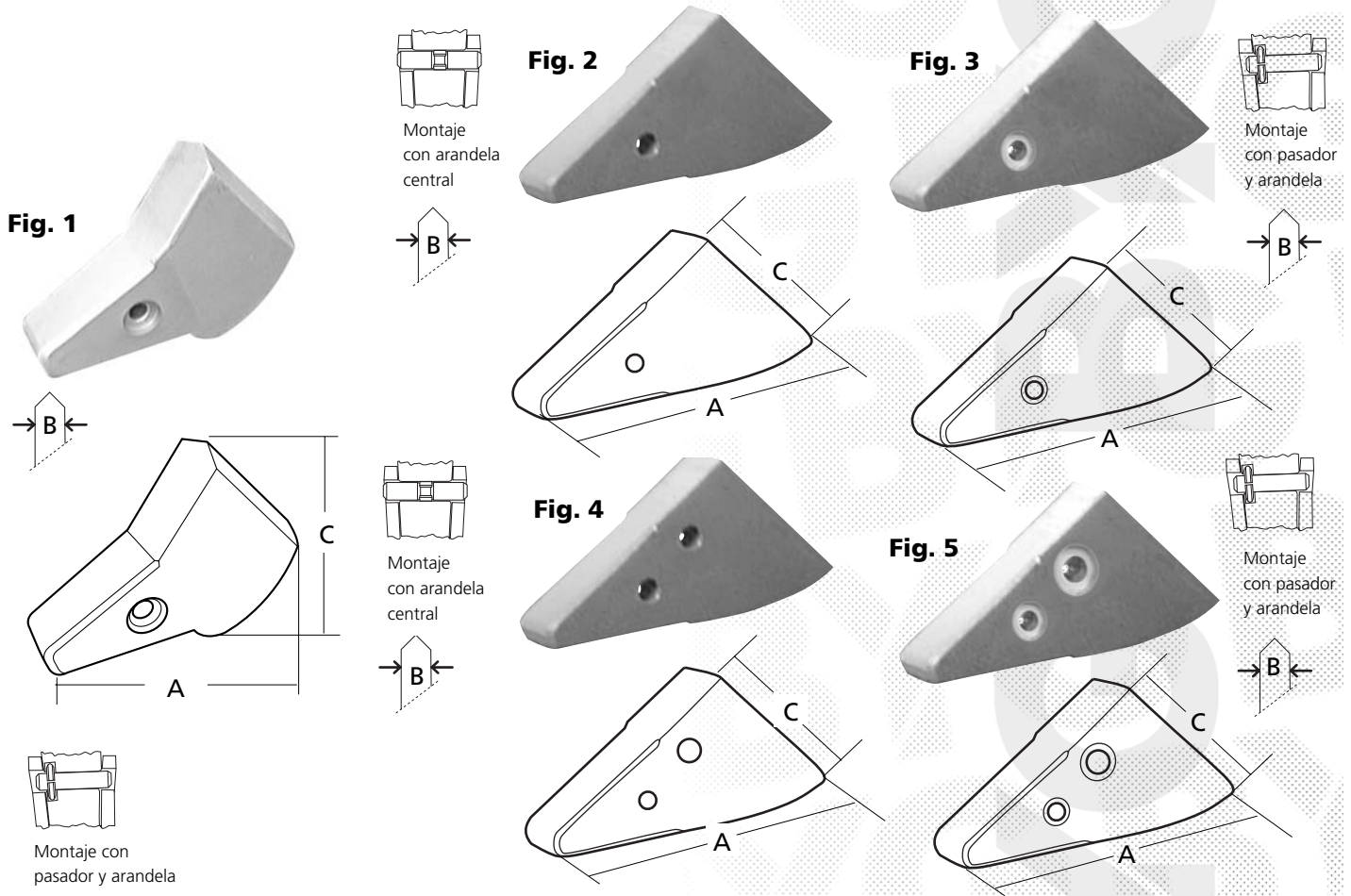

mm.	Fig 1	Fig 2	Fig 3	Fig 4	Fig 5	Pin and Washer		Pin		Washer		Mounting Method			
A B C															
200 60 150 7,87" 2,36" 5,91"	8E-7300	-	-	-	-	-	-	4T-4302 9W-7309 6Y-0309	-	9J-6583 1U-2405	-	-	-	D4, 941, 951, 955, 963, 12, 14, 130, 140, 143H, 160H	
200 75 250 7,87" 2,95" 9,84"	8E-7350	-	-	-	-	-	-	4T-4352 6Y-0359	-	8E-6358 1U-2405	-	-	-	16, 973, 977,D5, D6, D7, 983	
- - -	-	-	-	-	-	-	-	7J-3309 7J-3310 7J-3312	-	-	-	-	-	D7, D8, D9	
230 75 320 9,06" 2,95" 12,60"	-	-	-	4T-9776	-	6J-8811	-	9W-2451 9W-2452 9W-2452 ST 8E-5570 114-0453 4T-5451 4T-5452 8E-5571	7J-9600	-	7J-1792 7J-1793 7J-1795 107-3485 107-3486 8E-5346 4T-0135 4T-0136 8E-5342 8E-5340 8E-5341 4T-8989 4T-0134 4T-8990 8E-5347 7J-1794 8E-5345 9W-6167 4T-8988 8E-5340 4T-8990	-	-	D8K, D8L, D8N, D9H, D9N	
230 75 320 9,06" 2,95" 12,60"	-	-	-	-	-	-	6Y-3394 8E-4743	4T-5451 4T-5452 8E-5571	-	6Y-3394 8E-4743	-	-	-	-	
220 90 260 8,66" 3,54" 10,24"	-	4T-5819	-	-	-	-	-	4T-4501 4T-4502 4T-4502 ST	3G-0500	-	3G-2088 9W-4427 9J-5954 3G-5707	3G-6507 1V-4592 1U-4873 6Y-6138	-	D9L, D10, D10N, D11, D11N	
220 90 260 8,66" 3,54" 10,24"	-	-	103-8114	-	-	-	-	4T-4503 4T-5501 4T-5502 8E-5572 4T-5503	-	6Y-3909 4T-4707	-	6Y-6138 6Y-6144 6Y-6141 8E-8413 8E-8414 8E-8416 8E-8415 6Y-4679	6Y-5616 8E-8412 8E-8413 9W-8366 6Y-6147 8E-8411 8E-8417	-	-
260 90 350 10,24" 3,54" 13,78"	-	-	-	9W-9695P	-	3G-0500	-	4T-5503	3G-0500	-	-	-	-	-	
260 90 350 10,24" 3,54" 13,78"	-	-	-	-	107-3361	-	6Y-3909 4T-4707	-	-	6Y-3909 4T-4707	-	-	-	-	
- - -	-	-	-	-	-	-	-	9W-4551 9W-4552 6Y-3552	-	-	-	-	-	D11, D11N	
- - -	-	-	-	-	-	-	-	-	-	-	-	-	-	-	

Dientes de Ripper



Fig. 1

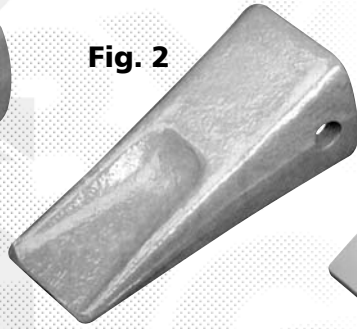
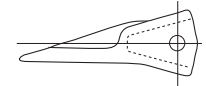

Fig. 2



Fig. 3



penetración:
buena penetración

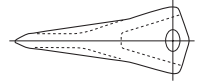

Diente simétrico:
más material
de desgaste

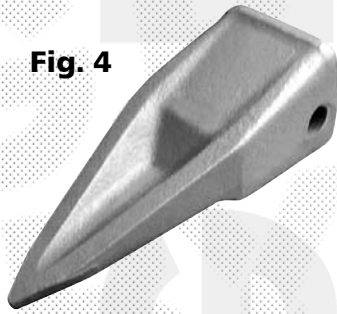
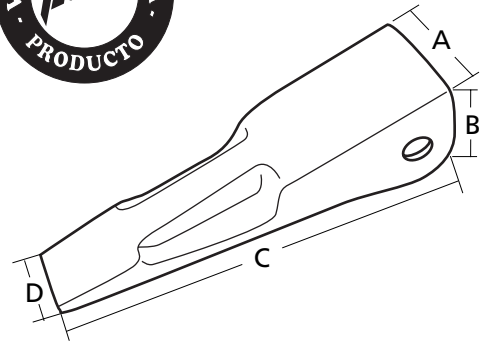

Fig. 4



Fig. 5



mm.						Fig	Forma											
A	B	C	D															
56	61	146	26	1,00	1U-3209	1	Largo	•	-	8E-6208	8E-6209	-	-	-	-	-	-	
2,20"	2,40"	5,75"	1,02"	2,20														
-	-	-	-	-	9W-8209	4	Afilado	•	-	8E-6208	8E-6209	-	D3	-	-	-	R200	
61	64	145	-	1,40	1U-3202	2	Largo	•	-	8E-6208	8E-6209	-	-	-	-	-	-	
2,40"	2,52"	5,71"	-	3,09														
76	88	193	32	2,40	9J-4259	1	Largo	•	-	8E-6208	8E-6209	-	-	-	-	-	-	
2,99"	3,46"	7,60"	1,26"	5,29														
65	73	164	65	2,29	1U-3251	2	Corto	•	-	8E-6208	8E-6209	-	943, 953	-	-	-	R250	
2,56"	2,87"	6,46"	2,56"	5,05														
76	89	215	-	2,60	1U-3252 TL	4	Afilado	•	-	8E-6208	8E-6209	-	-	-	-	-	-	
2,99"	3,50"	8,46"	-	5,73														
80	105	270	55	5,40	4T-4302	3	Largo	•	-	8J-1433	9J-6583	1U-2405	-	-	-	-	-	
3,15"	4,13"	10,63"	2,17"	11,90														
73	107	270	72	5,50	7K-0037	5	Corto	•	-	-	-	5K-1426	4K-0043	-	-	-	D4, 963, 14, 12	
2,87"	4,21"	10,63"	2,83"	12,13														
86	105	241	-	4,40	1U-3302 TL	4	Afilado	•	8J-1433	9J-6583	1U-2405	-	-	-	-	-	-	R300
3,39"	4,13"	9,49"	-	9,70														
-	-	-	-	-	168-1309	10	ARM	•	8J-1433	9J-6583	1U-2405	-	-	-	-	-	-	
82	101	287	48	5,40	6Y-0309	6	Largo	•	8J-1433	9J-6583	1U-2405	-	-	-	-	-	-	
3,23"	3,98"	11,30"	1,89"	11,90														
90	130	364	50	11,12	6Y-0352	3	Largo	•	7J-9600	8E-6358	1U-2405	-	-	-	-	-	-	
3,54"	5,12"	14,33"	1,97"	24,51														
108	138	385	-	11,12	6Y-0352 TL	4	Afilado	•	7J-9600	8E-6358	1U-2405	-	-	-	-	-	D5, D6, 973, 16, 977, D7	
4,25"	5,43"	15,16"	-	24,51														
105	133	360	50	11,50	6Y-0359	6	Largo	•	7J-9600	8E-6358	1U-2405	-	-	-	-	-	-	
4,13"	5,24"	14,17"	1,97"	25,35														
81	132	340	80	8,00	7K-0038	5	ARM	•	-	-	-	5K-1425	4K-0032	-	-	-	-	
3,19"	5,20"	13,39"	3,15"	17,64														
-	-	-	-	-	159-0355	10	Abrasivo	•	7J-9600	8E-6358	1U-2405	-	-	-	-	-	-	
115	137	302	110	11,60	7J-3309	7	Abrasivo	•	7J-9600	6Y-3394	8E-4743	-	-	-	-	-	-	
4,53"	5,39"	11,89"	4,33"	25,57														
115	137	325	88	11,68	7J-3310	7	Intermedio	•	7J-9600	6Y-3394	8E-4743	-	-	-	-	-	D7, D8	
4,53"	5,39"	12,80"	3,46"	25,75														
106	127	360	68	14,50	7J-3312	7	Largo	•	7J-9600	6Y-3394	8E-4743	-	-	-	-	-	-	
4,17"	5,00"	14,17"	2,68"	31,97														

Dientes de Ripper

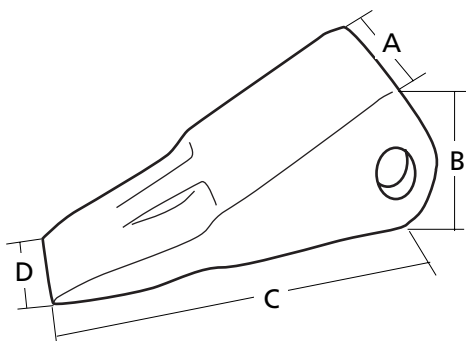

Fig. 6

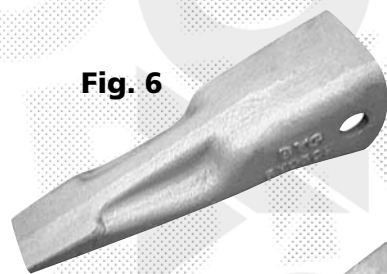

Fig. 7



Fig. 8



Fig. 9



Fig. 10

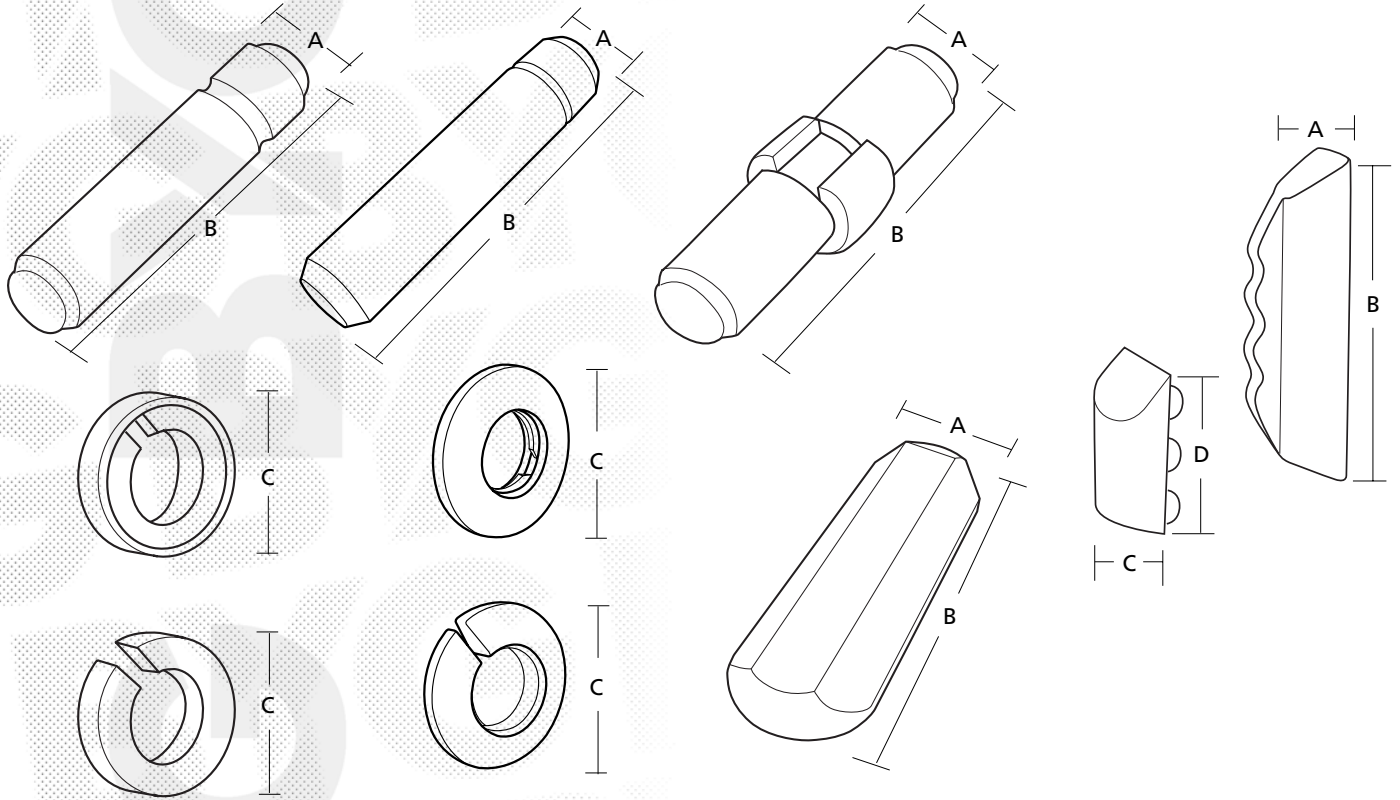

Fig. 11



mm.						Fig	Forma				
A	B	C	D								
122	163	341	78	15,00		8	Corto	•	7J-9600	6Y-3394 8E-4743	
4,80"	6,42"	13,43"	3,07"	33,07	FC450 R1						
127	167	379	90	21,00		8	Intermedio	•	7J-9600	6Y-3394 8E-4743	
5,00"	6,57"	14,92"	3,54"	46,30	FC450 R2						
126	170	387	78	17,50		9W-2452 ST 11	Abrasión	•	7J-9600	6Y-3394 8E-4743	
4,96"	6,69"	15,24"	3,07"	38,58							
-	-	-	-	-		8E-5770 10	ARM	•	7J-9600	6Y-3394 8E-4743	D8, D8L, D9, D8 K, D8 C, D8 N, D9 H, D9 N
126	165	425	84	20,00		114-0453 3	Largo	•	7J-9600	6Y-3394 8E-4743	R450
4,96"	6,50"	16,73"	3,31"	44,09							
125	168	340	50	14,60		9	Corto	•	7J-9600	6Y-3394 8E-4743	
4,92"	6,61"	13,39"	1,97"	32,19	FC450 R1						
66,8	166	390	54	17,75		9	Intermedio	•	7J-9600	6Y-3394 8E-4743	
2,63"	6,54"	15,35"	2,13"	39,13	FC450 R2						
-	-	-	-	-		8E-5771 10	ARM	•	7J-9600	6Y-3394 8E-4743	
-	-	-	-	-			Corto	•	3G-0500	6Y-3909 4T-4707	
-	-	-	-	-	FC500 R1	8					
152	218	440	75	30,00		8	Intermedio	•	3G-0500	6Y-3909 4T-4707	
5,98"	8,58"	17,32"	2,95"	66,14	FC500 R2						
152	218	453	75	30,30		4T-4502 ST 11	Abrasión	•	3G-0500	6Y-3909 4T-4707	
5,98"	8,58"	17,83"	2,95"	66,80							
158	216	477	73	32,00		4T-4503 3	Largo	•	3G-0500	6Y-3909 4T-4707	
6,22"	8,50"	18,78"	2,87"	70,55							
-	-	-	-	-		8E-5774 10	ARM	•	3G-0500	6Y-3909 4T-4707	D10N
147	214	380	80	24,00		9	Corto	•	3G-0500	6Y-3909 4T-4707	R500
5,79"	8,43"	14,96"	3,15"	52,91	FC500 R1						
152	218	440	75	27,30		9	Intermedio	•	3G-0500	6Y-3909 4T-4707	
5,98"	8,58"	17,32"	2,95"	60,19	FC500 R2						
-	-	-	-	-		8E-5772 10	ARM	•	3G-0500	6Y-3909 4T-4707	
153	223	480	76	29,20		4T-5503 6	Largo	•	3G-0500	6Y-3909 4T-4707	
6,02"	8,78"	18,90"	2,99"	64,37							
180	273	456	78	40,80		8	Corto	•	9W-1821	8E-2229 8E-2230	
7,09"	10,75"	17,95"	3,07"	89,95	FC550 R1						
-	-	-	-	-		8	Intermedio	•	9W-1821	8E-2229 8E-2230	D10N, D11SS
-	-	-	-	-	FC550 R2						R550
-	-	-	-	-		9	Intermedio	•	9W-1821	8E-2229 8E-2230	
-	-	-	-	-	FC550 R2						

Sujeción Ripper



mm.															
A	B	C	D												
11 0,43"	60 2,36"	19 0,75"	-	-	-	-	-	-	8E-6208	8E-6209	-	-	-	-	R200
14 0,55"	81 3,19"	29 1,14"	-	-	-	-	-	-	8E-6258	8E-6259	-	-	-	-	R250
19 0,75"	69 2,72"	23 0,91"	53 2,09"	4K-0043	5K-1426	-	-	-	-	-	-	-	-	-	-
19 0,75"	88 3,46"	-	-	-	-	-	-	8J-1433	-	-	-	-	-	-	R300
19 0,75"	88 3,46"	38 1,50"	-	-	-	-	-	-	9J-6583	-	1U-2405	-	-	-	-
19 0,75"	108 4,25"	38 1,50"	-	-	-	-	-	-	8E-6358	-	1U-2405	-	-	-	R350
21 0,83"	80 3,15"	23 0,91"	54 2,13"	4K-0032	5K-1425	-	-	-	-	-	-	-	-	-	-
25,4 1,00"	128 5,04"	-	-	-	-	-	-	7J-9600	-	-	-	-	-	-	R400
31,75 1,25"	115 4,53"	-	-	-	-	-	-	6J-8811	-	-	-	-	-	-	R450
25,4 1,00"	128 5,04"	48 1,89"	-	-	-	-	-	-	6Y-3394	8E-4743	-	-	-	-	R450
31,75 1,25"	153 6,02"	-	-	-	-	-	-	3G-0500	-	-	-	-	-	-	R500
31,75 1,25"	153 6,02"	64 2,52"	-	-	-	-	-	-	-	-	6Y-1204	6Y-1202	6Y-3909	4T-4707	R500
34,93 1,38"	155 6,10"	-	-	-	-	-	-	9W-1821	-	-	-	-	-	-	-
34,93 1,38"	170 6,69"	70 2,76"	-	-	-	-	-	-	-	-	9N-4245	6Y-1205	8E-2229	8E-2230	R550
35 1,38"	115 4,53"	-	-	-	-	-	-	8J-4889	-	-	-	-	-	-	-

Cruce de Ref.
sistema no reutilizable > reutilizable

No reutilizable	Reutilizable	No reutilizable	Reutilizable	
6Y-1204 >	6Y-3909	6Y-1202 >	4T-4707	R500
9N-4245 >	8E-2229	6Y-1205 >	8E-2230	R550