

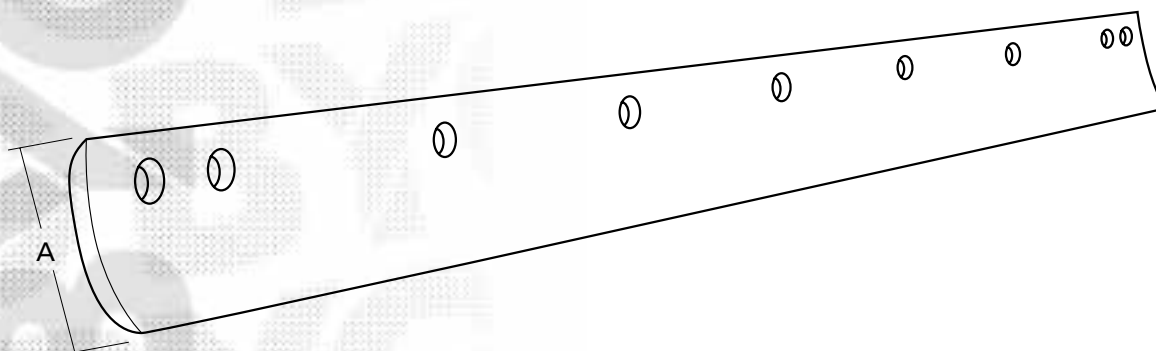





Cuchillas de Niveladora Curvas



A= 6" (152mm)

								Ø
5/8" 16 mm	5' - 1524 mm. 5B-5567	5' - 1524 mm. 7D-4508	6' - 1828 mm. *5B-5564-450	6' - 1828 mm. *5D-9553-450 9J-3657	7' - 2133 mm. *5B-5561-450	7' - 2133 mm. *5D-9554-450 9J-3658	8' - 2438 mm. 8J-4043 9J-3655	5/8" 3/4"
3/4" 19 mm		3G-7966		*5D-9556-450		5D-9557		5/8" 3/4"
	7	11	8	13	9	15	17	



A= 8" (203mm)

							Ø
5/8" 16 mm	2' - 610 mm 3G-2166	4' - 1219 mm.	5' - 1524 mm. 7D-4509	6' - 1828 mm. 5D-9562 9J-7701	7' - 2133 mm. 5D-9561 7D-1158	8' - 2438 mm. 5D-9731 8J-9821	5/8" 3/4"
3/4" 19 mm	6G-8623 3G-2165			*5D-9558-450 7D-1576	*5D-9559-450 *7D-1577-450	5D-9732 7D-1949	5/8" 3/4"
1" 25 mm			4T-2240	4T-2244 4T-2231	4T-2242 *4T-2233-450	4T-2237 *4T-2236-450	5/8" 3/4"
	4	9	11	13	15	17	



* Cuchillas de acero de 450 HB

Cuchillas de Niveladora Planas

A= 8" (203mm)

					Ø
5/8" 16 mm	5' - 1524 mm. 4T-2967	6' - 1828 mm. 4T-2968 4T-2971	7' - 2133 mm. 4T-2969 4T-2970	8' - 2438 mm. 4T-2966 4T-9603	5/8" 3/4"
3/4" 19 mm	4T-3034	4T-3007 4T-3033	4T-3036 4T-3032	4T-3035 4T-3037	5/8" 3/4"
1" 25 mm	7T-3497	7T-3499 7T-3493	7T-3498 7T-3494	7T-3496 7T-3495	5/8" 3/4"
	11	13	15	17	

A= 10" (254mm)

				Ø
1" 25 mm	6' - 1828 mm. 4T-6502	7' - 2133 mm. 4T-6508	8' - 2438 mm. 4T-6511	3/4"
	13	15	17	

Cantoneras de Niveladora

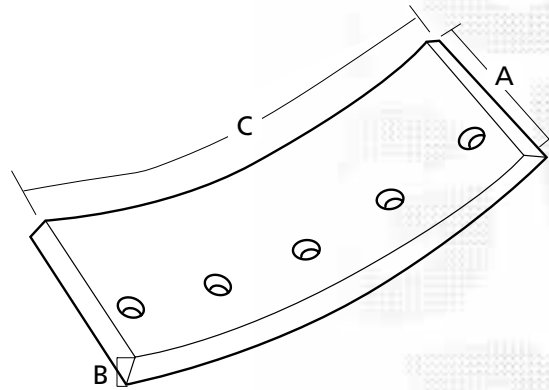

A	mm.		KG	Nº	Cuchilla	Bolt	Nut	Nº Tal	Serie	Tractor
	B"	C								
152	19,5	480	10	2	9D-4880/1	4F-7827	2J-3506	4	93U1-2777	16G
160	19,5	480	8,8		8E-5530	5J-4773	2J-3506	5	93U2778-UP	16G/H
152	5/8	480	7,3		4D-9811/2	3F-5108	4K-0367	4	Todas las demás	16
152	5/8	480	7,7	2	9J-4405/6	4F-7827	2J-3506	4	96U1-7324	14G
152	5/8	475	7,8		8E-5529	5J-4773	2J-3506	5	96U7325-UP	14G/H
152	1/2	553	6,5		7D-2083/4	3F-5108	4K-0367	5	Todas las demás	14
152	1/2	475	6,5	2	7D-2052 9W-2945	3F-5108	4K-0367	5	Todas	112,12, 120,130, 140
152	5/8	475	7,8	2	8E-5531	3F-5108	4K-0367	5	61M11716 y sigu 87V06135 y sigu) 74V02293 y sigu 72V09829 y sigu	12G/H 120G/H 130G 40G
			4,5	2	9J-4411	3F-5108	4K-0367	4	Todas	212
152	5/8	475	7,8	2	8E-5529	5J-4773	2J-3506	5	Todas	160H
152	5/8	475	7,9	2	8E-5531	3F-5108	4K-0367	5	Todas	135H

Sobrecantoneras de Niveladora

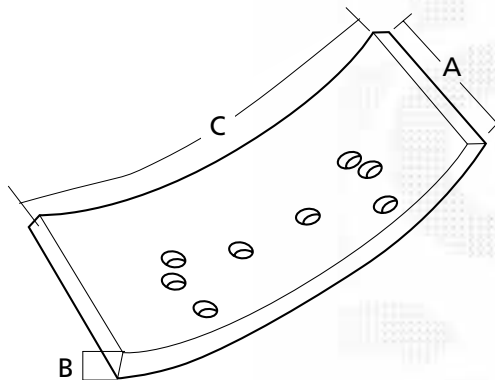

A	mm.		KG	Tipo	Cuchilla	Bolt	Nut	Nº tal	Cuchilla	Pulg	mm	Tractor	
	B"	C											
235	5/8	565	11,5	Rev-1	6D-1948 HD	4F-3658	4K-0367	203	Curva			12, 120, 130, 140 1ªSeries 14 1ªSeries 16 14G, 16G	
235	1/2	565	10,5		6D-1948	4F-3658	4K-0367						
235	1/2	585	12		7D-5583	1J-6762	2J-3506						
235	1/2	605	12,5		7D-1596	4F-3658	4K-0367						
235	5/8	600	12,5		7D-9999 HD	1J-6762	2J-3506						
235	1/2	600	11,5		7D-9999	1J-6762	2J-3506						
235	1/2	565	11,5	Rev-1	6Y-2805	1J-6762	2J-3506					14H, 16H, 14G 96U7325-UP 160H, 16G 93U2778-UP	
235	1/2	565	11,6	Rev-1	9W-1768	4F-3658	4K-0367					12H, 12G (61M11716 y sig), 120H, 120G, (87V06135 y sig), 135H, 130G, (74V02293 & ...), 140H, 140G, (72V09829 & ...)	
235	1/2	460	9,4		9W-1767	4F-3658	4K-0367						
235	5/8	475	10,5	Rev-1	6D-1904 HD	4F-3658	4K-0367			6"	152	6, 152, 12, 120, 130, 140, 1ªSeries 14-16	
235	1/2	475	9,5		6D-1904	4F-3658	4K-0367						
235	1/2	478	9	Rev-1	7D-5582	1J-6762	2J-3506			8"	203	1ªSeries 16	
230	5/8	490	9,5	No Rev-1	4D-5757/8	4F-3658	4K-0367			Plana	8"	203	12, 120, 130, 140, Ult. Series 14

Cuchillas de Pala



Fig 1

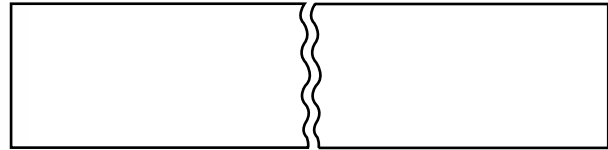

Fig 3

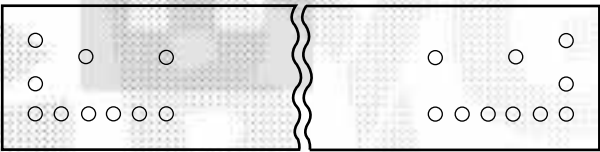

Fig 2

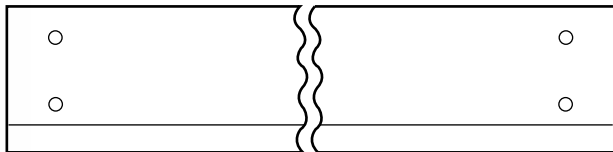

Fig 4

Ref.				Nº		Tipo
5G-2808	19	191	1823	14		5
6S-6501	19	191	1898	12		1
5G-8467	19	191	1950	14		5
5V-7419	25	245	2006	10		4
6W-2977	25	245	2018	28	6	2
9K-8471	25	228	2076			3
4V-8335	25	245	2078	16		1
9V-6571	25	245	2078	28	6	2
5G-2809	19	191	2080	12		5
5G-3085	19	191	2150	12		5
5G-6133	20	191	2150	24	6	2
9V-6570	25	245	2202	28	6	2
4V-8850	25	245	2202	16		1
6W-2978	32	282	2237	30	6	2
6W-2978	30	300	2237	30	6	2
6W-2978	32	282	2237	30	6	2
6W-2976	25	245	2248	28	6	2
8V-7453	25	245	2248	16		1
5V-7437	25	245	2248	16		4
9R-4672	20	150	2262	16	8	7
6W-2979	32	282	2268	30	6	2
4V-4958	30	282	2268	18		1
1V-9077	25	228	2286			3
5V-7426	25	245	2314	16		4
6W-2975	25	245	2324	28	6	2
5G-3477	19	191	2330	12		5

Ref.				Nº		Tipo
9V-6572	25	245	2370	16	6	2
5V-4670	25	245	2370	16		1
9R-5313	20	150	2396	16	8	4
6S-7291	20	191	2406	14	7	4
6W-2984	25	245	2408	28	8	2
6W-2986	25	245	2411	30		7
6W-2983	40	300	2430	30	6	2
5V-7263	32	282	2432	18		1
7V-0782	32	266	2438			3
5V-7423	25	245	2439	18		4
4V-3174	30	282	2474	18		1
6W-2980	30	282	2474	30	6	2
9K-8472	32	266	2489			3
8A-8443	25	245	2574	16		1
6W-2982	40	300	2602	30	6	2
5V-0600	40	300	2602	18		1
6W-2987	25	245	2615	30	6	2
6W-2985	25	245	2639	28	6	2
8V-1825	25	245	2639	16		1
5V-7422	25	245	2642	16		4
1V-3915	25	228	2686			3
5G-7303	40	300	2702	18		1
6W-2994	45	470	2705	12		7
9V-0255	51	330	2714			3
9V-6573	32	282	2736	30	6	2
5V-7421	25	245	2743	16		4

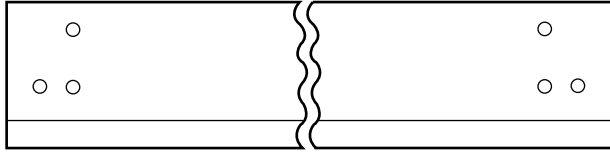

Fig 5



Fig 6

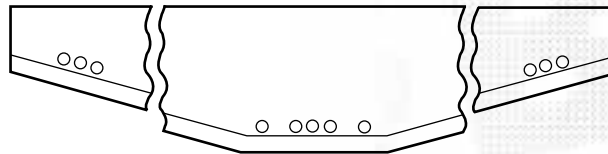

Fig 7

Ref.				N°		Tipo
5V-7410	25	245	2744	12		1
5V-4696	30	282	2800	18		1
7V-0898	40	300	2805	18		1
6W-2973	35	493	2815	18		7
9C-0967	35	493	2815			7
6W-2989	32	282	2840	30	6	2
6W-2981	40	300	2846	30	6	2
4V-9714	40	300	2846	18		1
6W-2990	32	282	2856	30	6	2
5V-7418	25	245	2890			3
7V-6844	40	300	2912	18		1
1V-3917	32	266	2921			3
8K-9915	32	266	2997			3
7V-1490	40	300	3032	18		1
9V-6575	40	300	3032	30	6	2
9V-1306	64	540	3035			3
7V-0912	30	282	3040	12		1
8K-5000	45	304	3067			3
6W-2993	45	580	3085	20		7
9V-0170	40	580	3085			7
9V-0237	50	330	3100			3
6W-2991	45	305	3179	30	6	2
7K-2326	45	304	3200			3
5V-7415	25	245	3226			3
8V-5031	32	282	3251	18		4
8K-5056	45	304	3270			3

Ref.				N°		Tipo
2V-6118	45	304	3286			3
9V-0235	50	330	3289			3
5V-7420	25	245	3302	18		4
7V-4188	45	305	3315	18		1
9V-6574	45	305	3315	30	6	2
7V-0909	40	300	3323	12		1
8V-9581	45	650	3370			7
9V-3561	45	647	3370	18		7
8V-5032	32	282	3404	20		4
8V-9583	60	700	3413			7
6W-9311	45	305	3560	18		1
3V-0187	45	304	3644	18		6
8V-9585	50	712	3644			7
9C-2932	50	330	3644	21	6	2
9V-0232	51	330	3644			3
9V-3562	50	706	3644	25		7
7V-0779	32	282	3810			3
8K-9048	57	830	4039			7
9V-0008	60	838	4312			7
9V-0009	57	445	4313			3
3V-3890	63,5	543	4597			3
9V-0006	63,5	838	4750			7
9V-0007	63,5	544	4750		8	3
9V-3570	63,5	921	4750			7
9V-3566	63,5	835	4750	28		7
9V-0005	63,5	921	4900			7
9V-4370	60	928	4900			7