

Adaptable Caterpillar

Referencia en negrita
producto disponible
Otras referencias
consúltenos

Diente Atornillable Monoblock

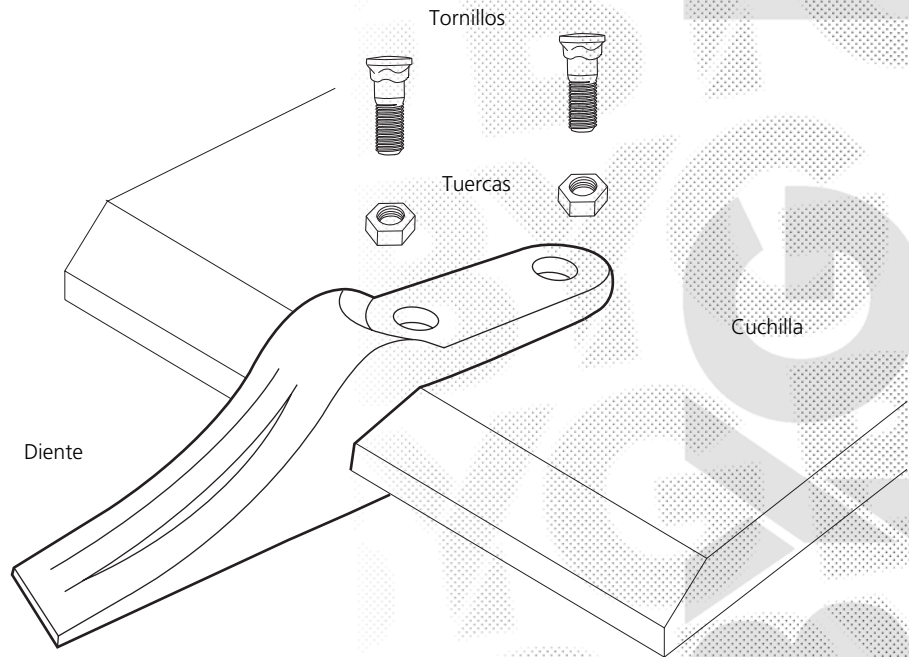

Diente						Cuchilla					Altura
1	2	3	4	5	6	7	8	9	10	11	
-	-	-	-	-	132-4720	-	-	-	-	216, 226, 236, 246	
135-9390	-	-	-	-	-	-	-	-	302.5	-	20
6Y-6335	1U-1869	1U-1868	-	-	-	-	-	416, 426, 428	-	-	
8J-6207	-	-	-	-	-	910	931	-	-	-	
1U-1857	1U-1859	1U-1858	6I-8389	6I-8388	-	916, 920, 924, 926, 930	936, 941, 943, 951, 953	-	-	-	25
1U-1877	1U-1879	1U-1878	8E-8609	8E-8608	-	950	955	-	-	-	
8E-1637	1U-1879	1U-1878	-	-	-	950B	955, 963	-	-	-	30
1U-1887	1U-1889	1U-1888	8E-5319	8E-5318	-	-	966C	-	-	-	
6Y-0649	1U-1889	1U-1888	8E-5319	8E-5318	-	973, 977	966D	-	-	-	35

Diente Monoblock

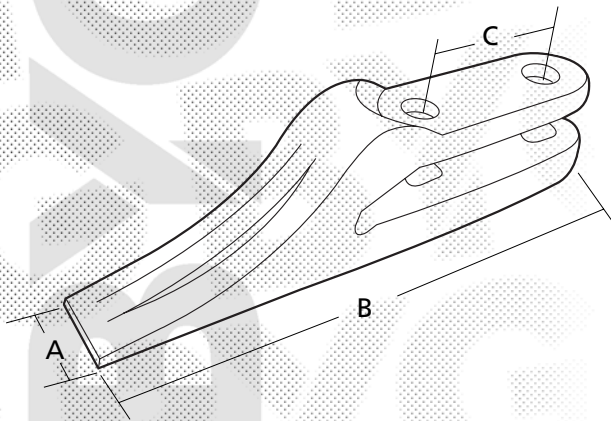

mm.														
A	B	C												
44	235	49	16	-	135-9390	PB-510	NP-158	-	-	302.5	-	-	-	
47	277	75	19	3,33	6Y-6335	4F-3656	4K-0367	-	-	-	-	-	416, 426, 428	20
1,85"	10,91"	2,95"	0,75"	7,34	9W-1879			1U-1869	1U-1868					
60	337	89	20	4,60	8J-6207	5J-4771	2J-3506	-	-	910	931	-	-	
2,36"	13,27"	3,50"	0,79"	10,14										
70	395	125	25	11,80	1U-1857	8J-2928	2J-3507	1U-1859	1U-1858	-	916, 920, 924, 926, 930	936, 941, 943, 951, 953	-	25
2,76"	15,55"	4,92"	0,98"	26,01										
100	410	124	25	12,30	1U-1877	8J-2928	8J-2933	-	-	950	955	-	-	
3,94"	16,14"	4,88"	0,98"	27,12				1U-1879	1U-1878					
72	470	165	32	16,40	8E-1637	1J-3527	8J-2928	-	-	950B	955, 963	-	-	30
2,83"	18,50"	6,50"	1,26"	36,16										
90	555	160	32	22,00	1U-1887	5P-8361	5P-8362	1U-1889	1U-1888	-	-	966C	-	
3,54"	21,85"	6,30"	1,26"	48,50										
-	-	-	38	-	6Y-0649	5P-8361				-	973, 977	966D	-	35

Cantoportadiente Monoblock

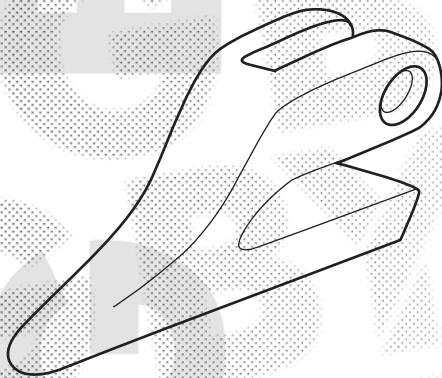

mm.												
A	B	D										
-	-	-	19	-	1U-1869	1U-1868	6F-0196	2J-3505	416, 426, 428			20
-	-	-	20	-	1U-1869	1U-1868			910, 931			
-	-	-	25	-	1U-1859	1U-1858	4J-9058 4J-9059	8J-2933	916, 920, 924, 926, 930, 936, 941, 943, 951, 953			25
-	-	-	25	-	1U-1879	1U-1878			955, 950			
-	-	-	32	-	1U-1879	1U-1878	5P-8823	5P-8362	955, 950B, 963			30
-	-	-	32	-	1U-1889	1U-1888			966C			
-	-	-	38	-	1U-1889	1U-1888			966D, 973, 977			35

Diente Monoblock

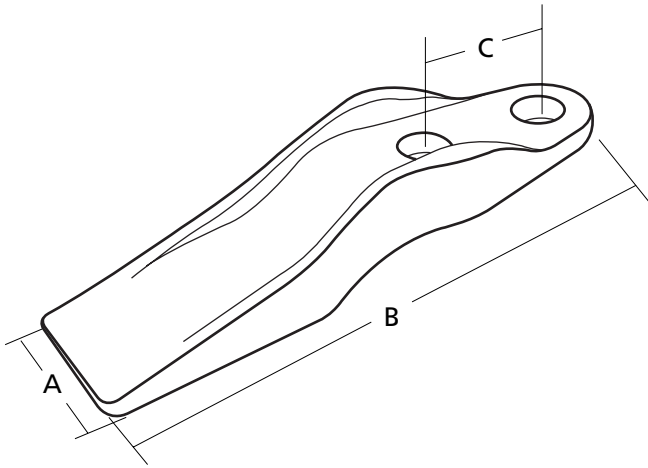





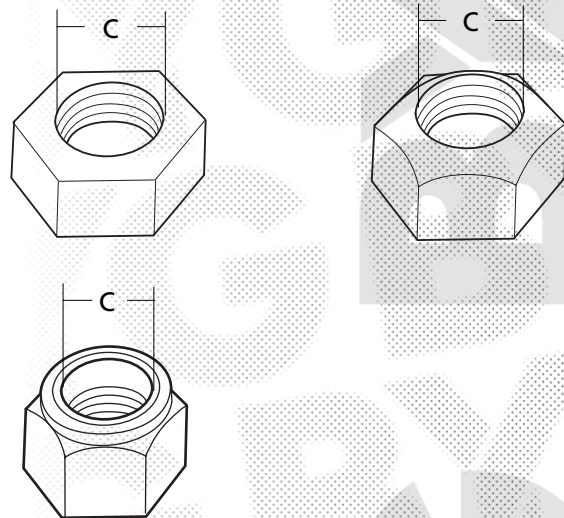
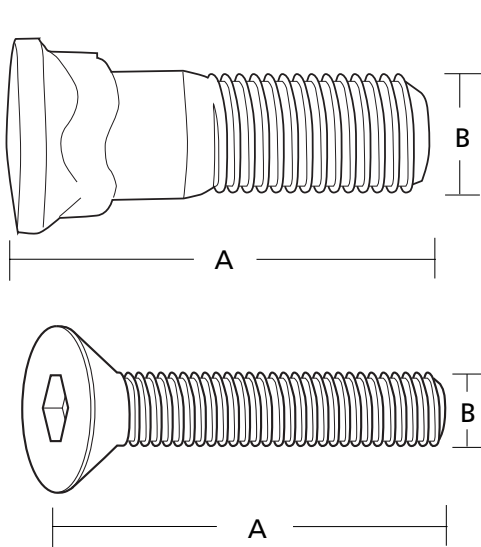

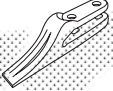

mm.									
A	B	C							
59 2,32"	235 9,25"	60 2,36"	20 0,79"	1,85 4,08	132-4720	V-16060	TA-016	216, 226, 236, 246	20

Tornillos y tuercas

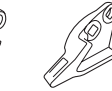
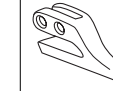
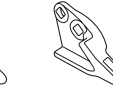

A	B	Hilos	Paso	Original	Ref. BYG	Original	Ref. BYG	C	Original	Ref. BYG	Original	Ref. BYG	Original	Ref. BYG
2 1/4"	5/8"	11	-		3F-5108 PB-510		-	-		-		-	-	-
2 1/2"	5/8"	11	-	4F-3656 PB-512	-	-	-	5/8"	4K-0367 NP-158	-	-	-	-	
2 1/2"	3/4"	10	-	5J-4771 PB-326	-	-	-	3/4"	2J-3506 NP-190	-	-	-	-	
2-3/4"	7/8"	9	-	6F-0196 PB-734	-	-	-	7/8"	2J-3505 NP-222	-	-	-	-	
3-1/4"	1"	8	-	4J-9058 PB-943	-	-	-	1"	-	-	-	-	-	
4-1/2"	1"	8	-	1J-3527 PB-948	-	-	-	1"	2J-3507 NP-100	8J-2933 NP-100B	-	-	-	
4"	1"	8	-	8J-2928 PB-946	-	-	-	1"	-	-	-	-	-	
4"	1-1/4"	7	-	5P-8823 PB-801	-	-	-	1-1/4"	-	-	5P-8362 NP-114B	-	-	
5"	1-1/4"	7	-	5P-8361 PB-805	-	-	-	1-1/4"	-	-	-	-	-	
60	M-16	-	2.00	-	-	159-2953	V-16060	M-16	-	-	-	-	8T-4778	TA-016

Sustitución de Diente y Portadiente a Sistema Monoblock

										
6I-6335	9W-6207									
8J-6207	9J-4207	1U-1869	1U-2209	1U-1868	1U-2208	-	-	-	-	20
1U-1857	1U-0257	1U-1859	3G-4259	1U-1858	3G-4258	6I-8389	6I-9251	6I-8388	6I-9250	25
1U-1877	1U-0307									
8E-1637	4T-5416	1U-1879	3G-4309	1U-1878	3G-4308	8E-8609	8E-5309	8E-8608	8E-5308	30
1U-1887	3G-9307	1U-1889	3G-8309	1U-1888	3G-8308	8E-5319	8E-5359	8E-5318	8E-5358	
6Y-0649	7I-7697	1U-1889	3G-5359	1U-1888	3G-5358	8E-5319	8E-5359	8E-5318	8E-5358	35

Adaptable Caterpillar

Componentes para Motoniveladoras

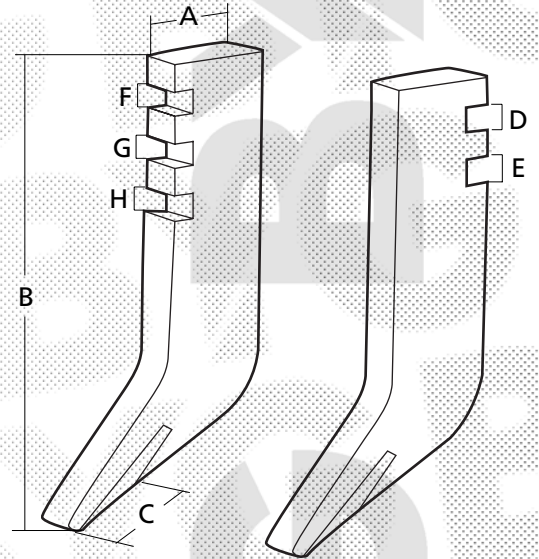

mm.												
A	B	C	D/E	F/G/H								
76	438	25	20	-	-	5B-6251	-					
2,99"	17,24"	0,98"	0,79"	-	5,70	-	9F-5124	6Y-5230	5K-1459	5K-1458	12, 14, 112,	130, 140
				20	12,57			2D-5572				
63	392	25	-	20	4,00	195-7219	-					
2,48"	15,43"	0,98"	-	0,79"	8,82							

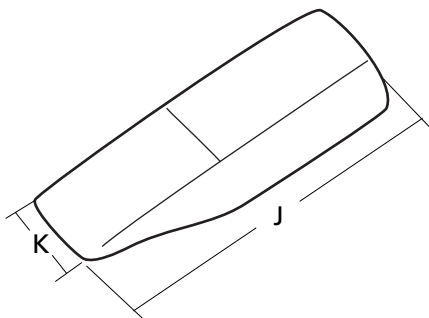

mm.								
J	K							
181	44	1,40	6Y-5230	5B-0947	9F-5124	5K-1459	5K-1458	12, 14, 112,
7,13"	1,73"	3,09	2D-5572		5B-6251			130, 140

Sujección

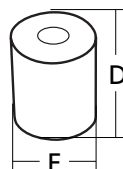
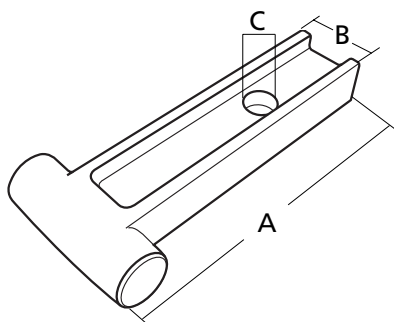

mm.						
A	B	C	D	E		
116	25	6	15	6	5K-1459	5K-1458
4,57"	0,98"	0,24"	0,59"	0,24"		

Adaptable Caterpillar

Zapatas de Compactador

Zapatas de Compactador



fig. 1



fig. 2

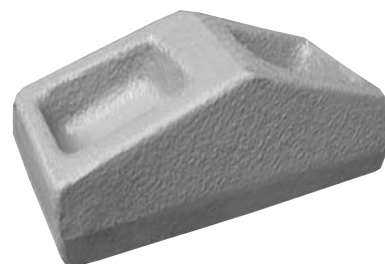
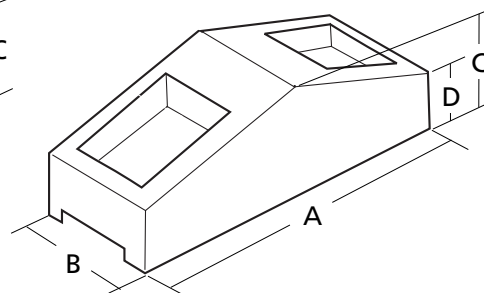
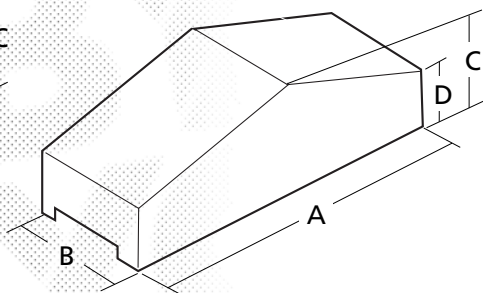
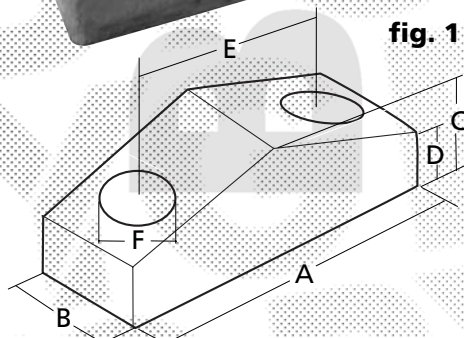
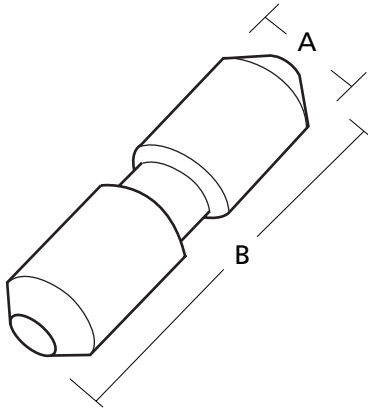

fig. 3



mm.							Zapata	Fig.	Ref.	Sistema Montaje	Nº Piezas Rueda					Base	
A	B	C	D	E	F												
170	70	64	33	114	17	3,55	Std.	1	8K-9189	Atornillable	-	8K-9163	7H-3607	5S-0581	-	7K-6957	815
6,69"	2,76"	2,52"	1,30"	4,49"	0,67"	7,83										7K-6957	815
170	81	71	41	-	-	3,70	HD	2	4V-3851	Soldable	-	-	-	-	-	7K-6957	815 815B
6,69"	3,19"	2,80"	1,61"	-	-	8,16											
168	81	71	41	-	-	4,10	Std.	3	2V-7053	Soldable	-	-	-	-	-	7K-6957	815B
6,61"	3,19"	2,80"	1,61"	-	-	9,04											
154	25	165	-	-	-	10,15	Std.	5	6W-0754	Soldable	24	-	-	-	-	-	816B
6,06"	0,98"	6,50"	-	-	-	22,38											
285	108	170	-	-	-	8,20	Std.	6	6W-0755	Soldable	16	-	-	-	-	-	816B
11,22"	4,25"	6,69"	-	-	-	18,08											

Sujección



mm.		
A	B	
19 0,75"	96 3,78"	7K-9535

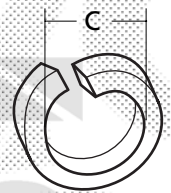
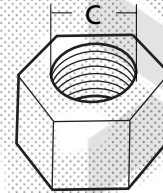
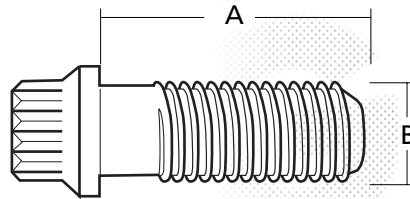

mm.		Original	BYG ref	C	Original	BYG ref	Original	BYG ref
A	B							
2"	5/8"		8K-9163 S12-5851	5/8"		7H-3607 N-058E		5S-0581 0-1258
2-1/2"	7/8"		8K-9164 S12-7863	7/8"		7H-3609 N-078E		4D-6419 0-1278

Zapatas de Compactador



Fig. 4

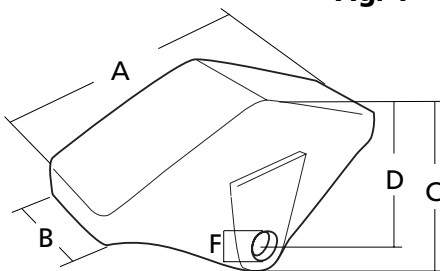

Fig. 5

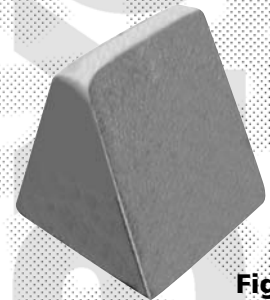
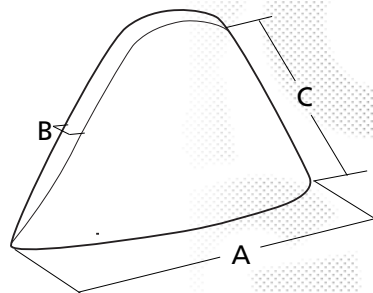
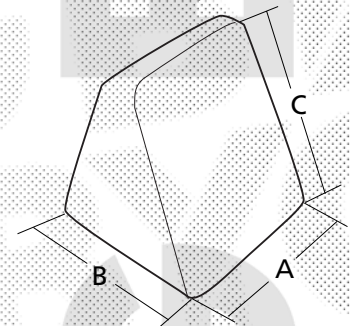
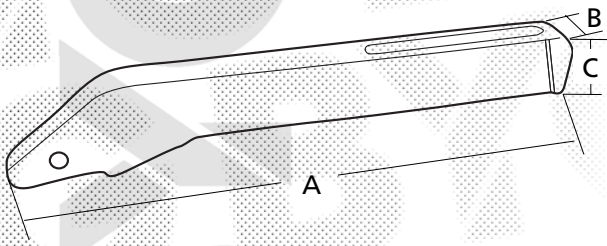

Fig. 6



mm.							Zapata Fig.	Ref.	Sistema Montaje	Nº Piezas Rueda					Base	
A	B	C	D	E	F											
226 8,90"	95 3,74"	124 4,88"	103 4,06"	-	19 0,75"	6,50 14,33	Std. 4	7K-2939	Pasador	-	-	-	-	7K-9535	9S-1645	824B 825B 834
225 8,86"	89 3,50"	89 3,50"	50 1,97"	-	-	6,25 13,78	Std. 3	2V-6628	Soldable	-	-	-	-	-	7K-7071	825C
214 8,43"	-	-	-	-	-	6,85 15,10	HD 2	4V-0668	Soldable	-	-	-	-	-	-	-
230 9,06"	78 3,07"	81 3,19"	40 1,57"	146 5,75"	24 0,94"	5,50 12,13	Std. 1	8K-9171	Atornillable	65	8K-9164	7H-3609	4D-6419	-	7K-7071	825C 835

Barra Limpiadora



mm.									
A	B	C							
550	50	60	10,00		5V-4311	3G-8250	8E-6258	8E-6259	815B
21,65"	1,97"	2,36"	22,05						

Diente Pala para Barra Limpiadora

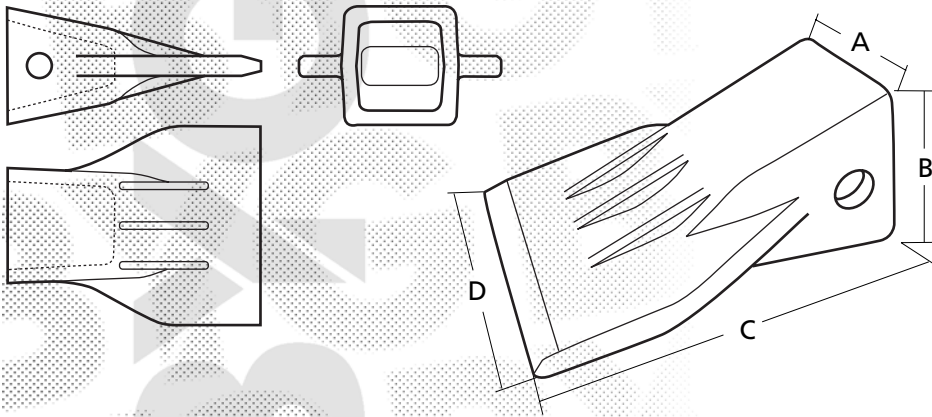

mm.									
A	B	C	D						
73	86	196	113	3,20	3G-8250	5V-4311	8E-6258	8E-6259	815B
2,87"	3,39"	7,72"	4,45"	7,05					

Sujeción

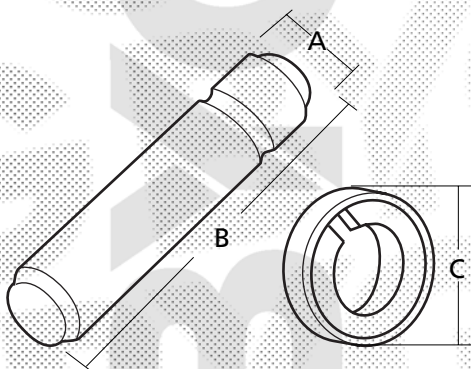

mm.				
A	B	C		
14	81	30	8E-6258	8E-6259
0,55"	3,19"	1,18"		