



Referencia en negrita
producto disponible

Otras referencias
 consúltenos

Adaptable Rippers Caterpillar

Dientes

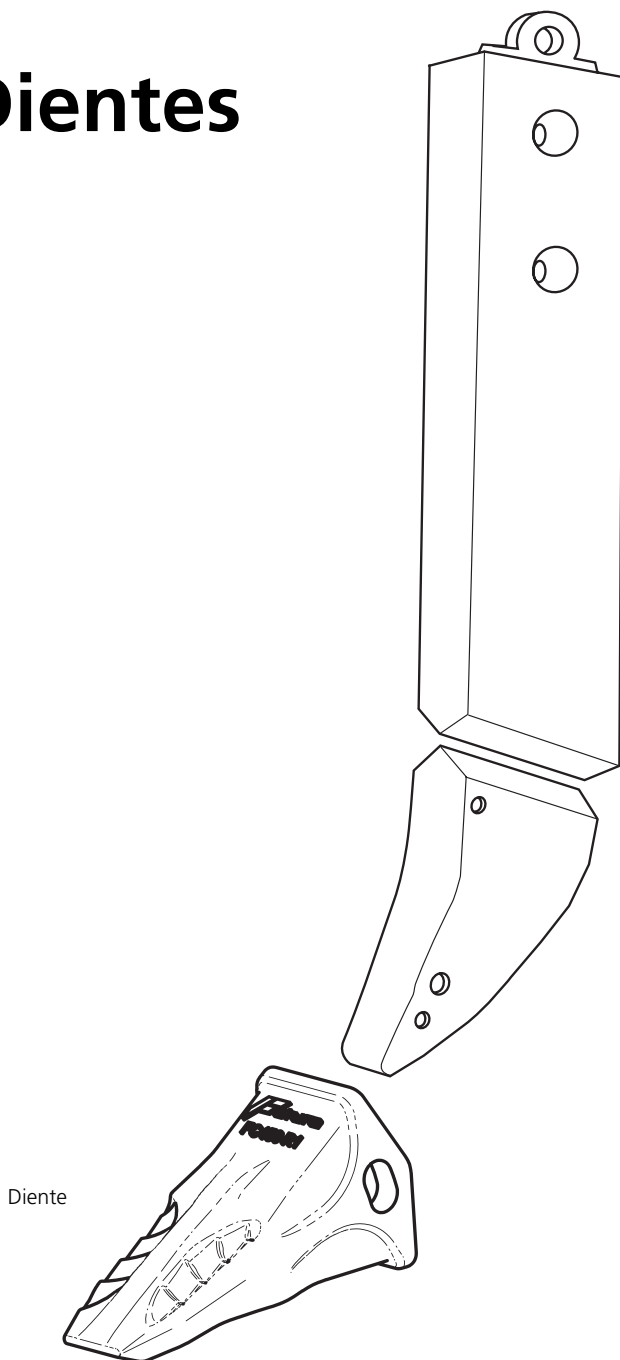

Componentes del Vástago de Ripper

R1	R2		
-	FC300 R2 4T-4302 6Y-0309	D4 963, 14, 12	R300
	FC350 R2 6Y-0352 6Y-0359	D5, D6, 973, 16, 977, D7	R350
FC450 R1 9W-2451 4T-5451	-	D8, D8 L, D9, D8 K, D8C, D8 N, D9 H, D9 N	R450
-	FC450 R2 9W-2452 4T-5452		
FC500 R1 4T-4501 4T-5501	-	D10 N	R500
-	FC500 R2 4T-4502 4T-5502		
FC550 R1 9W-4551	-	D10 N, D11SS	R550
-	FC550 R2 9W-4552 6Y-3552		

Dientes de Ripper

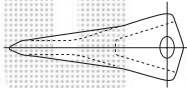

Diente simétrico:
más material
de desgaste

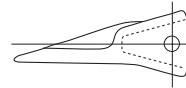

penetración:
buena penetración

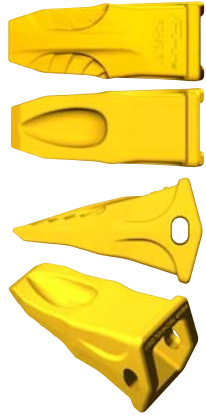

Fig. 1

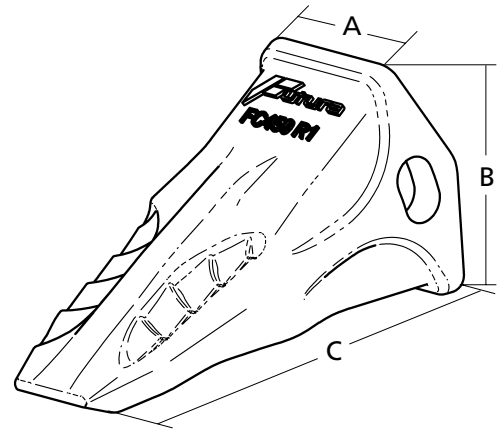
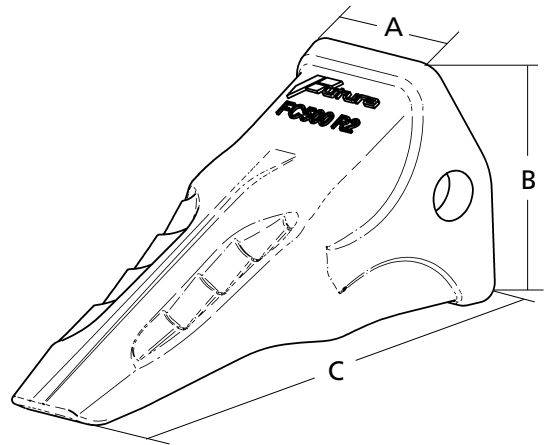
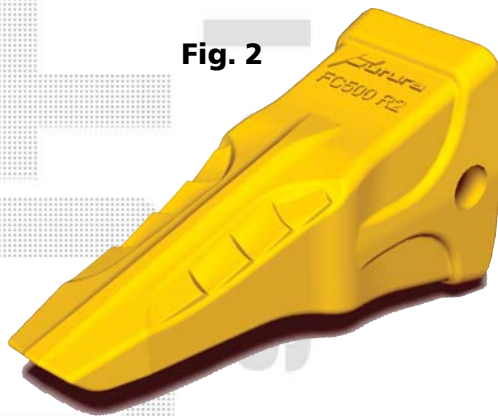
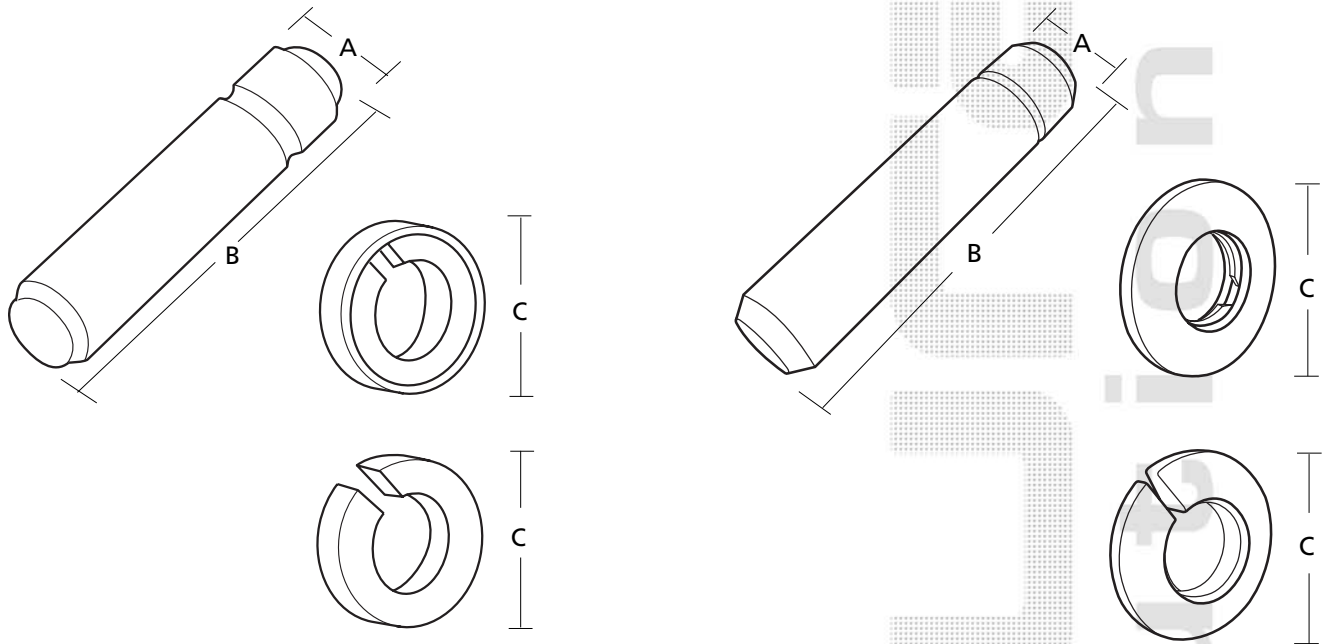









Fig. 2







mm.					Fig	Equivalencias Classic					
A	B	C									
94 3,70"	114 4,49"	295 11,61"	6,32 13,93	FC300 R2	2	4T-4302	6Y-0309	9J-6583	1U-2405	D4 963, 14, 12	R300
123 4,84"	164 6,46"	342 13,46"	14,00 30,86	FC350 R2	2	6Y-0352	6Y-0359	8E-6358	1U-2405	D5, D6, 973, 16, 977, D7	R350
139 5,47"	186 7,32"	344 13,54"	18,88 41,62	FC450 R1	1	9W-2451	4T-5451	6Y-3394	8E-4743	D8, D8 L, D9, D8 K, D8C, D8 N, D9 H, D9 N	R450
139 5,47"	186 7,32"	388 15,28"	20,58 45,37	FC450 R2	2	9W-2452	4T-5452				
156 6,14"	219 8,62"	414 16,30"	31,78 70,06	FC500 R1	1	4T-4501	4T-5501	6Y-3909	4T-4707	D10 N	R500
157 6,18"	219 8,62"	454 17,87"	31,00 68,34	FC500 R2	2	4T-4502	4T-5502				
176 6,93"	254 10,00"	480 18,90"	42,60 93,92	FC550 R1	1	9W-4551	-	8E-2229	8E-2230	D10 N, D11SS	R550
182 7,17"	250 9,84"	535 21,06"	45,76 100,88	FC550 R2	2	9W-4552	6Y-3552				

Sujeción Ripper



mm.									
A	B	C							
19 0,75"	88 3,46"	38 1,50"	9J-6583	1U-2405	-	-	-	-	R300
19 0,75"	108 4,25"	38 1,50"	8E-6358	1U-2405	-	-	-	-	R350
25,4 1,00"	128 5,04"	48 1,89"	6Y-3394	8E-4743	-	-	-	-	R450
31,75 1,25"	153 6,02"	64 2,52"	-	-	6Y-1204	6Y-1202	6Y-3909	4T-4707	R500
34,93 1,38"	170 6,69"	70 2,76"	-	-	9N-4245	6Y-1205	8E-2229	8E-2230	R550

Cruce de Referencias
sistema no reutilizable > reutilizable

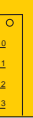
No reutilizable	Reutilizable	No reutilizable	Reutilizable	
				
6Y-1204 >	6Y-3909	6Y-1202 >	4T-4707	R500
9N-4245 >	8E-2229	6Y-1205 >	8E-2230	R550

Aututia

we are solutions