

the **sensor** people

Series 53 and 55

Stainless steel sensor platform
for the beverage, packaging and
pharmaceutical industries

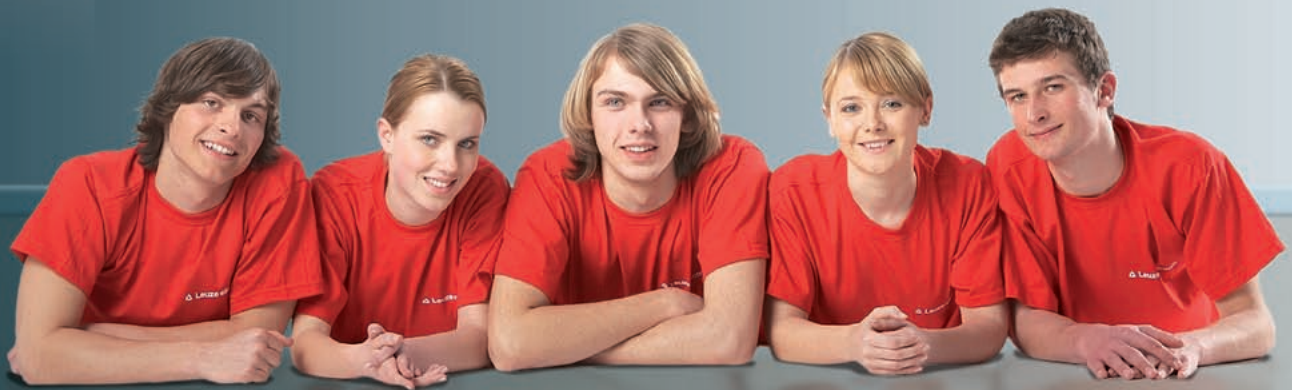

Absolutely **leak-proof** and **reliable** –
even under the most demanding conditions.

Our new stainless steel sensor platform.

The new **Leuze stainless steel Series 53 and 55 sensors** were specially designed for applications with **increased hygiene requirements** and where machines are subjected to intense cleaning and disinfection cycles. To meet these demanding conditions, the sensor housings are made of an especially **high-quality V4A stainless steel (AISI 316L)**. Moreover, the construction process included special emphasis on ensuring that the glass-free optics cover as well as the operating elements are **absolutely leak-proof and gap-free**. This ensures the reliable function and leak-proofness of the systems, even after years of use, and prevents bacterial carry-overs.



Outside: **the best stainless steel**; inside: **proven technology**.
Together: a **unique sensor platform**.

With our stainless steel sensor platform, we are keeping in step with market demands.

Increasingly strict hygiene regulations, particularly in the food and pharmaceutical industries, and the use of new cleaning procedures and cleaning agents also place new requirements on the sensors which are used as well as their functional reliability.

The housings of our Series 55 and 53 sensors with their respective WASH-DOWN and HYGIENE-DESIGNS, were specially

designed for these applications and, as a result, offer optimum protection for a broad range of integratable sensor technologies which already perform reliably in other series. This compatibility in optical, electrical and mechanical respects – and the associated standardised functionality and operation of the devices – facilitates simpler integration of the sensors and minimises testing and documentation expenses.

Dry applications
Series 3B



Wet applications
Series 55



Hygiene applications
Series 53



The scalable housing technology facilitates optical, electrical and mechanical compatibility of the sensors.

Absolute reliability in wet applications.

The **Series 55** sensors in **WASH-DOWN** Design.

Our Series 55 stainless steel sensors show their strength particularly in the wet areas of your production line. With the innovative WASH-DOWN Design of our sensors, it is possible to thoroughly clean the entire system with all common cleaning agents and processes. The non-diffusive and chemically resistant materials

used in the optics and operational controls, as well as the absolutely gap-free construction of the sensors, prevents bacterial carry-overs. Moreover, the enclosed housing technology and expanded temperature range ensure long-lasting functionality of the systems.

Seal: TPV (chemically resistant against cleaning agents)

Housing: V4A stainless steel (AISI 316L) WASH-DOWN-Design

Enclosed housing technology: Bacterial carry-overs are prevented

Optics cover: PMMA+ with special coating, stable for H₂O₂ and wipe-down cleaning with 70% alcohol

Operation: Smooth TPV, disinfectable and non-diffusive

Fastening: V4A stainless steel (AISI 316L), prepared for M4 thread

Electrochemical device labelling: Long-term stability and disinfectable

Connector / cable: V4A / PVC Disinfectable and non-diffusive

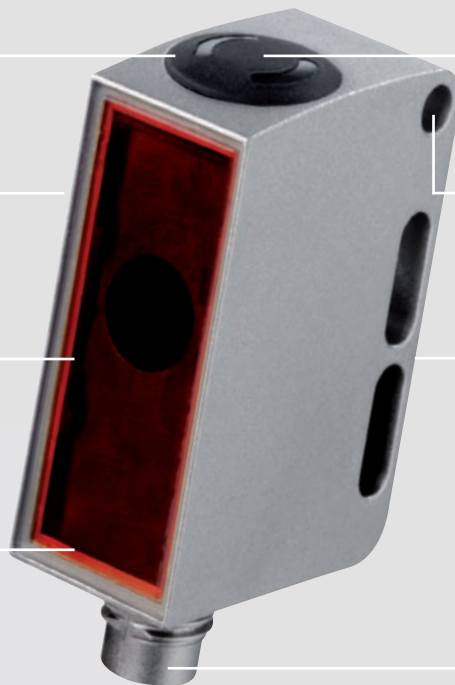

Without compromise in hygienic applications. The **Series 53** sensors in the **HYGIENE-Design**.

The Series 53 line of sensors was specially designed for sensitive hygiene applications, e.g. in the pharmaceutical, cosmetic and foods industries. Based on the fundamental elements of the Series 55 sensors, this special development in housing design provides an even higher level of protection against bacterial carry-overs.

The smooth housing contours without attachment holes greatly reduce all types of deposits. The unique fastening concept, which consists of a mounting trunnion with 12 mm diameter and G6 fit, ensures a gas-tight connection between sensor and machine.

Seal: TPV (chemically resistant against cleaning agents)

Operation: Smooth TPV, disinfectable and non-diffusive

Housing: V4A stainless steel (AISI 316L) HYGIENE-Design

Enclosed housing technology: Gas-tight, bacterial carry-overs are prevented

Electrochemical device labelling: long-term stability and disinfectable

Optics cover: PMMA+ with special coating, stable for H₂O₂ and wipe-down cleaning with 70% alcohol

Fastening: V4A (AISI 316L)
Gas-tight adaptation, diameter 12 mm, fit G6

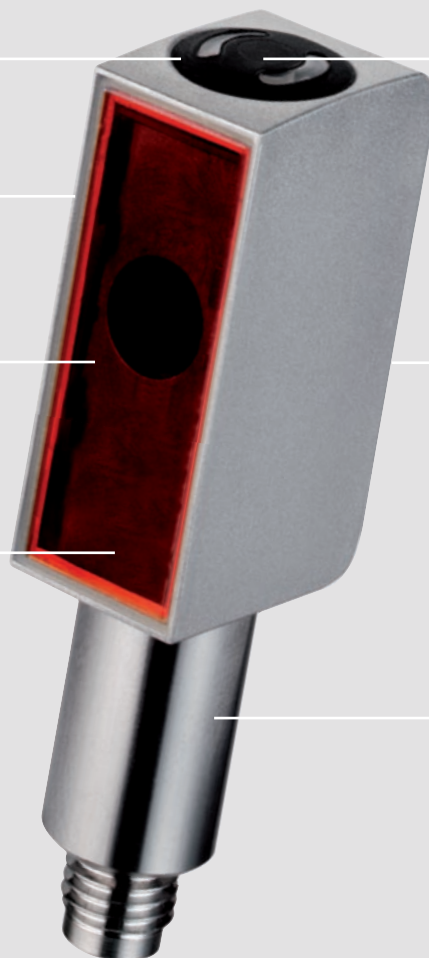

The "PLUS" makes the difference.

ECOLAB and ECOLAB+

In addition to the standard ECOLAB and IP 67 / IP 69K certification, the Series 53 and 55 sensors are also tested in accordance with expanded, Leuze-specific test procedures. Under the ECOLAB+ designation, the products are subjected to an entire series of additional aggressive cleaning agents at temperatures of 50°C

ECOLAB

IP 67 + IP 69K

Ecolab test method

F&E No. 40-1

Static and immersion tests:

Complete submersion in the test medium

Test duration: 28 days

Temperature: 20°C

Products:

P3-topaktiv 200, P3-topax 19, P3-topax 56, P3-topax 91

before being forced to demonstrate their leak-proofness under the mechanical load of a steam-jet cleaner. For the pharmaceutical test, the Series 53 sensors in HYGIENE-Design are also tested against H₂O₂ and 70% alcohol to ensure that they satisfy these special requirements as well.

ECOLAB+

IP 67 + IP 69K

Leuze test method

(based on ECOLAB F&E No. 40-1)

Static and immersion tests:

Complete submersion in the test medium

Test duration: 28 days

+ Temperature: 50°C

+ Additional products:

P3-topaktiv DES, P3-topax 52, P3-topax 66, P3-steril, P3-lubodrive Tk

+ Additional cleaning products for the pharmaceutical test:

H₂O₂ (20°C), 70% alcohol (60 min., 20°C)

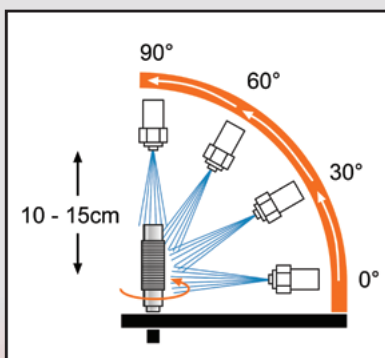

The right choice for durability and hygiene.

The application possibilities of our stainless steel sensor platform are as diverse as the proven Leuze electronic technology which is available for use with the platform.

The right solutions for the following industries and applications.

- Food processing
(meat, baked goods, chocolate, ...)
- Food filling
(beer, soft drinks, liquids, milk, fruit juice, ...)
- Pharmaceutical (fluid, powder, liquid, ...)
- Cosmetic (fluid, powder, liquid, ...)
- Luxury articles (tobacco, ...)
- Handling / assembly in the pharmaceutical industry

Available device technologies for Series 53 and 55.

- Throughbeam photoelectric sensors
- Retro-reflective photoelectric sensors for materials handling
- Retro-reflective photoelectric sensors for exact positioning
- Retro-reflective photoelectric sensors for glass and PET detection
- Retro-reflective photoelectric sensors for foil detection
- Laser retro-reflective photoelectric sensors for the detection of small parts
- Scanners with background suppression and high scanning range
- Scanners with small light spot for the detection of glossy and structured objects
- Scanners with elongated light spot for the detection of transparent objects as well as objects with openings, holes and press cuts





Specifications



Specifications	Series 55	Series 53
Operating voltage	10 ... 30V DC	10 ... 30V DC
Temperature range	-25 ... +60 °C / +70 °C	-25 ... +60 °C / +70 °C
Safety class	IP 67 + IP 69K long life	IP 67 + IP 69K long life
Connection system	M8 / M12 / cable	M8 / M12 / cable
Housing material	V4A / AISI 316L	V4A / AISI 316L
Optics material	PMMA-coated	PMMA-coated
Operation	TPE	TPE
Housing technology	100% enclosed	100% enclosed
Device labelling	Electrochemical process	Electrochemical process
Design	WASH-DOWN	HYGIENE
Chemical resistance	ECOLAB+	ECOLAB+
Fastening	Standardised hole pattern	Fit G6, diameter 12 mm

Chemical resistance				
Product group	Product designation	Concentration	Temperature	Application time
Foam cleaner	P3-topactive 200	4 %	20 °C	28 days
Foam cleaner	P3-topax 19	5 %	20 °C	28 days
Foam cleaner	P3-topax 56	5 %	20 °C	28 days
Disinfection agent	P3-topax 91	3 %	20 °C	28 days
Foam cleaner	P3-topactive 200	4 %	50 °C	21 days
Disinfection agent	P3-topactive DES	3 %	50 °C	21 days
Foam cleaner	P3-topax 52	5 %	50 °C	21 days
Disinfection agent	P3-topax 66	5 %	50 °C	21 days
Disinfection agent	P3-steril	1 %	50 °C	21 days
Conveyor belt lubricant	P3-lupodrive	0.1 %	50 °C	21 days
Disinfection agent	Hydrogen peroxide H ₂ O ₂	6 %	20 °C	21 days
Disinfection agent	Peracetic acid	1 %	20 °C	21 days
Disinfection agent	Ethanol	70 %	20 °C	10 hours *

ECOLAB
ECOLAB+

* corresponds to approx. 5000 wipe cycles at 10 sec. per cycle.

ECOLAB	Test procedure according to Ecolab F&E No. 40-1
ECOLAB+	Leuze test procedure (based on Ecolab F&E No. 40-1)

The sensors show no loss of function following the application times specified above.

Optoelectronic Sensors

Cubic Series
Cylindrical Sensors, Mini Sensors, Fibre Optic Amplifiers
Measuring Sensors
Special Sensors
Light Curtains
Forked Sensors
Double Sheet Monitoring, Splice Detection
Accessories

Identification Systems

Data Transmission Systems

Distance Measurement

Barcode Readers
RF-IDent-System
Modular Interfacing Units
Industrial Image Processing Systems
Optical Data Transmission Systems
Optical Distance Measurement/Positioning
Hand-Held Readers

Safety Sensors

Safety Systems

Safety Services

Safety Laser Scanners
Safety Light Curtains
Transceiver and Multiple Light Beam Safety Devices
Single-Beam Safety Devices
AS-i-Safety Product Range
Safety Sensor Technology for PROFIBUS DP
Safety Switches and Safety Locking Devices
Safety Relays and Safety Interfaces
Sensor Accessories and Signal Devices
Machine Safety Services

Leuze electronic GmbH + Co. KG

In der Braike 1

73277 Owen/Germany

Phone +49 70 21 / 573-0

Telefax +49 70 21 / 573-199

info@leuze.de

www.leuze.de